

Generator

Kohler Model: KG100

This gas generator set equipped with a 4R9X alternator operating at 120/208 volts is rated for 100 kW/125 kVA. Output amperage: 347

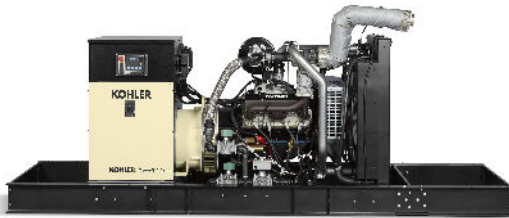

Standard Features:

- EPA-Certified for Stationary Emergency Applications
- Kohler Co. provides one-source responsibility for the generating system and accessories.
- The generator set and its components are prototype-tested, factory-built, and production-tested.
- The 60 Hz generator set offers a UL 2200 listing.
- CSA approval is available.
- The 60 Hz generator set meets NFPA 110, Level 1, when equipped with the necessary accessories and installed per NFPA standards.
- The generator set accepts rated load in one step.
- A one-year limited warranty covers all generator set systems and components. Two-and five-year extended limited warranties are also available.
- Natural gas, LP gas, and dual fuel models are available.
- Air Cleaner Restrictor Indicator
- Alternator Protection
- Battery Rack and Cables
- Electronic, Isochronous Governor
- Gas Fuel System
- Integral Vibration Isolation
- Local Emergency Stop Switch
- Oil Drain Extension
- Operation and Installation Literature

Alternator Features:

- Open Unit Accessory Kit
- The unique Fast-Response™ X excitation system delivers excellent voltage response and short-circuit capability using a rare-earth, permanent magnet (PM)-excited alternator.
- The brushless, rotating-field alternator has broad range reconnectability.

Qty	Description
7	KG100 Generator System KG100 Generator Set Includes the following: Literature Languages Approvals and Listings Engine Nameplate Rating Voltage Alternator Cooling System Skid and Mounting Air Intake Controller Enclosure Type Enclosure Material Starting Aids, Installed Electrical Accy., Installed Electrical Accy., Installed Electrical Accy., Installed Rating, LCB 1 Amps, LCB 1 Trip Type, LCB 1 Interrupt Rating LCB 1 Miscellaneous Accy, Installed Warranty Testing, Additional Flexible Fuel Line (Nat/LP) Literature, General Maintenance, KG100 RSA III, Annunciator only
	English UL2200 Listing/cUL Genset List SnglFuel, UL, PreAlarm, NG, Stdby Standby 130C Rise 60Hz, 120/208V, Wye, 3Ph, 4W 4R9X Unit Mounted Radiator, 50C Skid, 44" Standard Duty APM402 Sound Steel 1500W, 110-120V Battery, 1/12V, Wet Battery Charger, 10A Run Relay 100% Rated 400 Electronic, LSI 35kA at 480V Coolant in Genset 5 Year Comprehensive Power Factor Test, 0.8, 3Ph Only

KOHLER®

Spec Sheets

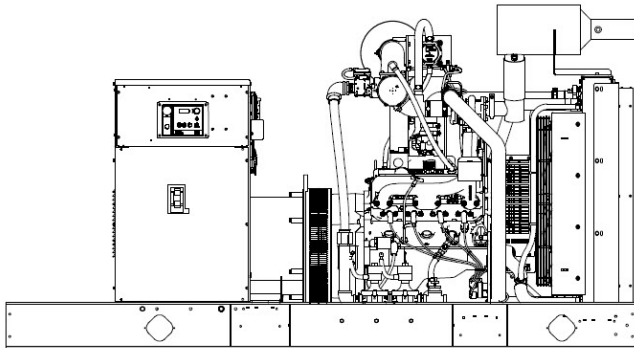

Standard Features

- EPA-Certified for Stationary Emergency Applications
- Kohler Co. provides one-source responsibility for the generating system and accessories.
- The generator set and its components are prototype-tested, factory-built, and production-tested.
- The 60 Hz generator set offers a UL 2200 listing.
- CSA approval is available.
- The 60 Hz generator set meets NFPA 110, Level 1, when equipped with the necessary accessories and installed per NFPA standards.
- The generator set accepts rated load in one step.
- A one-year limited warranty covers all generator set systems and components. Two- and five-year extended limited warranties are also available.
- Natural gas, LP gas, and dual fuel models are available.
- Air Cleaner Restrictor Indicator
- Alternator Protection
- Battery Rack and Cables
- Electronic, Isochronous Governor
- Gas Fuel System
- Integral Vibration Isolation
- Local Emergency Stop Switch
- Oil Drain Extension
- Operation and Installation Literature

Alternator Features

- Open Unit Accessory Kit
- The unique Fast-Response™ X excitation system delivers excellent voltage response and short-circuit capability using a rare-earth, permanent magnet (PM)-excited alternator.
- The brushless, rotating-field alternator has broad range reconnectability.

Generator Set Rating

				Standby 130C Rise Ratings	
Alternator	Voltage	Ph	Hz	kW/kVA	Amps
4R9X	120/208	3	60	100/125	347

RATINGS: All three-phase units are rated at 0.8 power factor. All single-phase units are rated at 1.0 power factor.

Standby Ratings: The standby rating is applicable to varying loads for the duration of a power outage. There is no overload capability for this rating. Ratings are in accordance with ISO-8528-1 and ISO-3046-1. For limited running time and continuous ratings, consult the factory. Obtain technical information bulletin (TIB-101) for ratings guidelines, complete ratings definitions, and site condition derates.

The generator set manufacturer reserves the right to change the design or specifications without notice and without any obligation or liability whatsoever.

For dual fuel engines, use the natural gas ratings for both the primary and secondary fuels.

Model: KG100, continued

Alternator Specifications

Specifications	Alternator
Alternator manufacturer	Kohler
Type	4-Pole, Rotating-Field
Exciter type	Brushless, Rare-Earth Permanent-Magnet
Leads, quantity	4RX: 12, Reconnectable, 4TX: 4, 110-120/220-240 V
Voltage regulator	Solid State, Volts/Hz
Insulation	NEMA MG1
Insulation: Material	Class H
Insulation: Temperature Rise	130 ° C, Standby
Bearing: quantity, type	1, Sealed
Coupling	Flexible Disc
Amortisseur windings	Full
Voltage regulation, no-load to full-load Permanent magnet (PM) alternator	Controller Dependent
One-Step Load Acceptance	100% of rating
Unbalanced load capability	100% of Rated Standby Current

- The unique Fast-Response X excitation system delivers excellent voltage response and short-circuit capability using a rare-earth, permanent magnet (PM) -excited alternator.
 - The brushless, rotating-field alternator has broadrange reconnectability.
 - NEMA MG1, IEEE, and ANSI standards compliance for temperature rise and motor starting.
 - Sustained short-circuit current of up to 300% of the rated current for up to 10 seconds.
- Sustained short-circuit current enabling downstream circuit breakers to trip without collapsing the alternator field.
 - Self-ventilated and dripproof construction.
 - Superior voltage waveform from two-thirds pitch windings and skewed stator.
 - Windings are vacuum-impregnated with epoxy varnish for dependability and long life.

Engine

Engine Specification

Engine Manufacturer	Kohler
Engine Model	KG6208THD 6.2L
Engine: type	Turbocharged, Aftercooled
Cylinder arrangement	V-8
Displacement, L (cu. in.)	6.2 (378)
Bore and stroke, mm (in.)	101.6 x 95.25 (4.00 x 3.75)
Compression ratio	9.8:1
Rated rpm	1800
Max. power at rated rpm, kWm (BHP)	152 (204)
Cylinder head material	Cast Aluminum
Piston: type, material	Cast Aluminum
Crankshaft material	Forged Steel
Valve (exhaust) material	Forged Steel
Governor: type, make/model	Electronic
Frequency regulation, no-load to-full load	Isochronous
Frequency regulation, steady state	± 1.0%
Frequency	Fixed
Air cleaner type, all models	Dry

Model: KG100, continued

Exhaust

Exhaust System

Exhaust Manifold Type	Dry
Exhaust flow at rated kW, m ³ /min. (cfm)	24 (848)
Exhaust temperature at rated kW, dry exhaust, °C (°F)	700 (1292)
Maximum allowable back pressure, kPa (in. Hg)	14.9 (4.4)
Exh. outlet size at eng. hookup, mm (in.)	88.9 (3.5)

Engine Electrical

Engine Electrical System

Ignition system	Coil Pack
Battery charging alternator: Ground (negative/positive)	Negative
Battery charging alternator: Volts (DC)	12
Battery charging alternator: Ampere rating	130
Starter motor rated voltage (DC)	12
Battery, recommended cold cranking amps (CCA): Qty., CCA rating each	One, 650
Battery voltage (DC)	12

Fuel

Fuel System

Fuel type	Natural Gas
Fuel supply line inlet	1.5 NPT
Natural gas/LPG fuel supply pressure, kPa (in. H ₂ O). Fuel supply pressure measured at the generator set fuel inlet downstream of any fuel system equipment accessories.	1.74-2.74 (7.11)

Fuel Composition

Fuel Composition

Natural Gas: Methane, % by volume	90 min.
Natural Gas: Ethane, % by volume	4.0 max.
Natural Gas: Propane, % by volume	1.0 max.
Natural Gas: Propene, % by volume	0.1 max.
Natural Gas: C4 and higher, % by volume	0.3 max.
Natural Gas: Sulfur, ppm mass	25 max.
Natural Gas: Lower heating value, kJ/m ³ (Btu/ft ³), min.	33.2 (890)

* Fuels with other compositions may be acceptable. If your fuel is outside the listed specifications, contact your local distributor for further analysis and advice.

Lubrication

Lubrication System

Type	Full Pressure
Oil pan capacity, L (qt.)	5.7 (6.0)
Oil pan capacity with filter, L (qt.)	9.0 (9.5)
Oil filter: quantity, type	1, Cartridge

Model: KG100, continued

Cooling

Radiator System

Ambient temperature, ° C (° F)	50 (122)
Engine jacket water capacity, L (gal.)	7.3 (1.93)
Radiator system capacity, including engine, L (gal.)	28.4 (7.5)
Engine jacket water flow, Lpm (gpm)	126 (33.3)
Heat rejected to cooling water at rated kW, dry exhaust, kW (Btu/min.)	73.9 (4207)
Water pump type	Centrifugal
Fan diameter, including blades, mm (in.)	711 (28)
Fan, kWm (HP)	12 (16.1)
Max. restriction of cooling air, intake and discharge side of radiator, kPA (in. H2O)	0.125 (0.5)

* Enclosure with internal silencer reduces ambient temperature capability by 5 ° C (9 ° F).

Operation Requirements

Air Requirements

Radiator-cooled cooling air, m3/min. (scfm) *	290 (10241)
Combustion air, m3/min. (cfm)	6.9 (244)
Heat rejected to ambient air: Engine, kW (Btu/min.)	30 (1708)
Heat rejected to ambient air: Alternator, kW (Btu/min.)	8 (455)

*Air density = 1.20 kg/m³ (0.075 lbm/ft³)

Fuel Consumption

Natural Gas, m3/hr. (cfh) at % load

Rating

Standby Fuel Consumption at 100% load	41.7 m3/hr. (1473 cfh)
Standby Fuel Consumption at 75% load	34.7 m3/hr. (1224 cfh)
Standby Fuel Consumption at 50% load	26.8 m3/hr. (946 cfh)
Standby Fuel Consumption at 25% load	17.7 m3/hr. (625 cfh)
Standby Fuel Consumption at 0% load	8.3 m3/hr. (292 cfh)

Kohler® APM402 Controller**General Description and Function**

The APM402 generator set controller provides advanced control, system monitoring, and system diagnostics for optimum performance.

The APM402 controller meets NFPA 110, Level 1 when equipped with the necessary accessories and installed per NFPA standards.

The APM402 controller uses a patented hybrid voltage regulator and unique software logic to manage alternator thermal overload protection features normally requiring additional hardware. Additional features include:

- A digital display and pushbutton/rotary selector dial provide easy local access to data.
- Measurements selectable in metric or English units.
- The controller can communicate directly with a personal computer via a network or serial configuration using SiteTech™ or Monitor III software.
- The controller supports Modbus® protocol. Use with serial bus or Ethernet networks. (Ethernet requires an external Modbus®/Ethernet converter module.)
- Scrolling display shows critical data at a glance.
- Digital display of power metering (kW and kVA).
- Integrated hybrid voltage regulator providing $\pm 0.5\%$ regulation.
- Built-in alternator thermal overload protection.

Modbus® is a registered trademark of Schneider Electric.

**APM402**

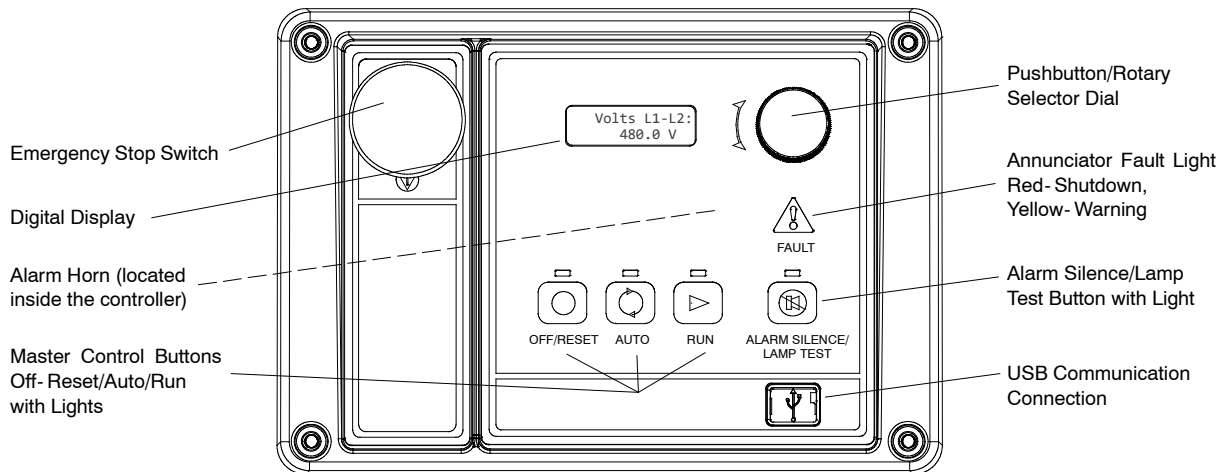

User Interface Controls and Components

- Emergency stop switch
- Backlit LCD digital display with two lines of 12 characters (see *User Interface Displays for menus*)
- Alarm horn indicates generator set shutdown and warning faults
- Environmentally sealed membrane keypad with three master control buttons with lights
 - Off/Reset (red)
 - Auto (green)
 - Run (yellow)
- Pushbutton/rotary selector dial for menu navigation
 - Rotate dial to access main menus
 - Push dial and rotate to access sub menus
 - Press dial for 3 seconds to return to top of main menu
- Annunciator fault light
 - System shutdown (red)
 - System warning (yellow)
- Alarm silence/lamp test button
 - Alarm silence
 - Lamp test
- USB and RS-485 connections
 - Allows software upgrades
 - Provides access for diagnostics
 - PC communication using SiteTech™ or Monitor III software
- Dedicated user inputs
 - Remote emergency stop switch
 - Remote 2-wire start for transfer switch
 - Auxiliary shutdown
- Integrated hybrid voltage regulator
- Auto-resettable circuit protection mounted on circuit board.
- One relay output standard. Optional five relay output available.
- One analog and three digital inputs standard. Optional two inputs available.

NFPA 110 Requirements

In order to meet NFPA 110, Level 1 requirements, the generator set controller monitors the engine/generator functions/faults shown below.

- Engine functions:
 - Overcrank
 - Low coolant temperature warning
 - High coolant temperature warning
 - High coolant temperature shutdown
 - Low oil pressure shutdown
 - Low oil pressure warning
 - High engine speed
 - Low fuel (level or pressure) *
 - Low coolant level
 - EPS supplying load
 - High battery voltage
 - Low battery voltage
- General functions:
 - Master switch not in auto
 - Battery charger fault *
 - Lamp test
 - Contacts for local and remote common alarm
 - Audible alarm silence button
 - Remote emergency stop *

* Function requires optional input sensors or kits and is engine dependent, see Controller Displays as Provided by the Engine ECM.

User Interface Displays

The listing below has ● denoting main menus and ○ denoting sub-menus.

- Overview
 - Software version
 - Active shutdowns and warnings (if any are present)
 - Engine run time, total hours
 - Average voltage line-to-line
 - Frequency
 - Average current
 - Coolant temperature
 - Fuel level or pressure *
 - Oil pressure
 - Battery voltage
- Engine Metering
 - Engine speed
 - Oil pressure
 - Coolant temperature
 - Battery voltage
- Generator Metering
 - Total power, VA
 - Total power, W
 - Rated power, %
 - Voltage, L- L and L- N for all phases
 - Current, L1, L2, L3
 - Frequency
- GenSet Information
 - Generator set model number
 - Generator set serial number
 - Controller serial number
- GenSet Run Time
 - Engine run time, total hours
 - Engine loaded, hours
 - Number of engine starts
 - Total energy, kWh
- GenSet System
 - System voltage
 - System frequency, 50 or 60 Hz
 - System phase, single or three (wye or delta)
 - Power rating, kW
 - Amp rating
 - Power type, standby or prime
 - Measurement units, metric or English (user selectable)
 - Alarm silence, always or auto only (NFPA 110)
 - Manual speed adjust *
- GenSet Calibration
 - Voltage, L- L and L- N for all phases
 - Current, L1, L2, L3
 - Reset calibration
- Voltage Regulation
 - Adjust voltage, ±10%
- Digital Inputs
 - Input settings and status
- Digital Outputs
 - Output settings and status
- Analog Inputs
 - Input settings and status
- Event Log
 - Event history (stores up to 1000 system events)
- Selector Switch (requires initial activation by SiteTech™)

Controller Features

- **AC Output Voltage Regulator Adjustment.** The voltage adjustment provides a maximum of $\pm 10\%$ of the system voltage.
- **Alarm Silence.** The controller can be set up to silence the alarm horn only when in the AUTO mode for NFPA-110 application or Always for user convenience.
- **Alternator Protection.** The controller provides generator set overload and short circuit protection matched to each alternator for the particular voltage/phase configuration.
- **Automatic Restart.** The controller automatic restart feature initiates the start routine and re crank after a failed start attempt.
- **Common Failure Relay.** This relay is integrated on the controller circuit board. Contacts are rated 2 amps at 32 VDC or 0.5 amp at 120 VAC.
- **Communication.** Controller communication is available.
- **Cyclic Cranking.** The controller has programmable cyclic cranking.
- **ECM Diagnostics.** The controller displays engine ECM fault code descriptions to help in engine troubleshooting.
- **Engine Start Aid.** The starting aid feature provides control for an optional engine starting aid.
- **Event Logging.** The controller keeps a record (up to 1000 entries) for warning and shutdown faults. This fault information becomes a stored record of system events and can be reset.
- **Historical Data Logging.** Total number of generator set successful starts is recorded and displayed.
- **Integrated Hybrid Voltage Regulator.** The voltage regulator provides $\pm 0.5\%$ no-load to full-load regulation with three-phase sensing.
- **Lamp Test.** Press the alarm silence/lamp test button to verify functionality of the indicator lights.
- **LCD Display.** Adjustable contrast for improving visibility.
- **Measurement Units.** The controller provides selection of English or metric displays.
- **Power Metering.** Controller digital display provides kW and kVA.
- **Programming Access (USB).** Provides software upgrades and diagnostics.
- **Remote Reset.** The remote reset function resets faults and allows restarting of the generator set without going to the master control switch off/reset position.
- **Remote Monitoring Panel.** The controller is compatible with the Kohler® Remote Serial Annunciator.
- **Run Time Hourmeter.** The generator set run time is displayed.
- **Time Delay Engine Cooldown (TDEC).** The TDEC provides a time delay before the generator set shuts down.
- **Time Delay Engine Start (TDES).** The TDES provides a time delay before the generator set starts.
- **Voltage Selection Menu.** This menu provides the capability of quickly switching controller voltage calibrations. Requires initial activation using SiteTech™ software. **NOTE:** Generator set output leads require voltage reconnection.

Controller Functions

The following chart shows which functions cause a warning or shutdown. All functions are available as relay outputs.

Warning causes the fault light to show yellow and sounds the alarm horn signaling an impending problem.

Shutdown causes the fault light to show red, sounds the alarm horn, and stops the generator set.

	Warning Function	Shutdown Function
Engine Functions		
Critically high fuel level *	○	
ECM communication loss		●
ECM diagnostics	●	●
Engine over speed		●†
Engine start aid active		
Engine under speed		●
Fuel tank leak *	○	○
High battery voltage	●	
High coolant temperature	●	●†
High fuel level *	○	
Low battery voltage	●	
Low coolant level		●
Low coolant temperature	●	
Low cranking voltage	●	
Low engine oil level *	○	○
Low fuel level (diesel models) *	○	○
Low fuel pressure (gas models) *	○	
Low oil pressure	●	●†
No coolant temperature signal		●
No oil pressure signal		●
Overcrank		●†
Speed sensor fault	●	
General Functions		
Alarm horn silenced		
Analog inputs	○	○
Battery charger fault *	●	
Chicago code active *		
Common fault (includes †)		●
Common warning	●	
Digital inputs	○	○
Emergency stop		●†
Engine cooldown (delay) active		
Engine start delay active		
Engine started		
Engine stopped		
EPS supplying load		
Generator running		
Input/output communication loss	●	
Internal failure		●
Master switch not in auto	●	
NFPA 110 alarm active		
Remote start		
System ready		
Generator Functions		
AC sensing loss	●	●
Alternator protection		●
Ground fault input *	●	
kW overload		●
Locked rotor		●
Overfrequency		●
Overvoltage (each phase)		●
Underfrequency		●
Undervoltage (each phase)		●

● Standard function

○ Available user function

* Function requires optional input sensors or kits and is engine dependent; see Controller Displays as Provided by the Engine ECM.

† Items included with common fault shutdown

Controller Displays as Provided by the Engine ECM	Engine Manufacturer (and Model)						
	Kohler Diesel (KDI M, TM*)	Kohler Diesel (KDI TCR)	Kohler Gas (KG2204, KG2204T)	Kohler Gas (KG6208, KG6208T, KG10V08, KG10V08T)	GM and PSI/Doosan	John Deere	Volvo
Intake air pressure							D
Intake air Temperature		D		D	D	D	D
Coolant level			D	D	D	D	D
Coolant temperature		D	C/S/D	C/S/D	C/S/D	C/S/D	C/S/D
Crankcase pressure							D
ECM battery voltage	S		S/D	S	S		
Engine speed	C/S/D	C/S/D	C/S/D	C/S/D	C/S/D	C/S/D	C/S/D
Fuel pressure		D		C/S/D	C/S/D	C/S†	C/S/D
Fuel temperature		D				S/D	S
Oil level				S†	S†	S†	S†
Oil pressure		C/S/D	D	C/S/D	C/S/D	C/S/D	C/S/D
Oil temperature			S				SD

C = Value displayed on controller, S = Value displayed in Site Tech, D = ECU diagnostic is supported
 * Electronic governor and ECM are optional on KDI M and TM engines.
 † Controller uses local analog input to obtain this information.

Note: REOZMD/ROZMC (Mitsubishi engines) have an ECM but do not send signals to the generator set controller.

Note: See the generator set specification sheet for engine model identification.

Controller Specifications

- Power source with circuit protection: 12- or 24-volt DC
- Power drain: 200 milliamps at 12 VDC or 100 milliamps at 24 VDC
- Humidity range: 5% to 95% noncondensing
- Operating temperature range: -40°C to +70°C (-40°F to +158°F)
- Storage temperature range: -40°C to +85°C (-40°F to +185°F)
- Standards:
 - CE Directive
 - NFPA 99
 - NFPA 110, Level 1
 - CSA 282-09
 - UL 508
 - ASTM B117 (salt spray test)
- Panel dimensions—W x H, 229 x 160 mm (9.0 x 6.3 in.)

Communication and PC Software Available Options

Refer to G6-76 Monitor III Software and the communication literature for additional communication and PC software information including Modbus® communication.

- Monitor III Software for Monitoring and Control (Windows®-based user interface)**
- Converter, Modbus®/Ethernet.** Supports a power system using controllers accessed via the Ethernet. Converter is supplied with an IP address by the site administrator. Refer to G6-79 for converter details.
- Converter, RS-232/RS-485.** Supports a power system using controllers accessed via a serial (RS-232) connection.

APM402 Available Options

- Float/Equalize Battery Charger** available with 6 or 10 amp output for 12 or 24V DC voltage output. The 10 amp model provides NFPA 110 charging and alarming capability.
- Manual Speed Adjust** available for applications using closed transition ATS. Adjustment range for 60 Hz: 1751- 1849 rpm (58.2- 61.8 Hz) and for 50 Hz: 1451- 1549 rpm (48.2- 51.8 Hz).
- Prime Power Switch** prevents battery drain during generator set non-operation periods and when the generator set battery cannot be maintained by an AC battery charger.
- Remote Emergency Stop Switch** available as a wall mounted panel to remotely shut down the generator set.
- Remote Monitoring Panel.** The Kohler® Remote Serial Annunciator (RSA) enables the operator to monitor the status of the generator set from a remote location, which may be required for NFPA 99 and NFPA 110 installations, and up to four Automatic transfer switches.
- Run Relay** provides a relay indicating that the generator set is running.
- Shunt Trip Wiring** provides relay outputs to trip a shunt trip circuit breaker and to signal the common fault shutdowns. Contacts rated at 10 amps at 28 VDC or 120 VAC.
- Two Input/Five Output Module** provides a generator set mounted panel with two inputs and five relay outputs.

Windows® is a registered trademark of Microsoft Corporation.
 Modbus® is a registered trademark of Schneider Electric.

DISTRIBUTED BY:

Availability is subject to change without notice. Kohler Co. reserves the right to change the design or specifications without notice and without any obligation or liability whatsoever. Contact your local Kohler® generator set distributor for availability.

© 2018 Kohler Co., All rights reserved.

Line Circuit Breakers 15-3250 kW

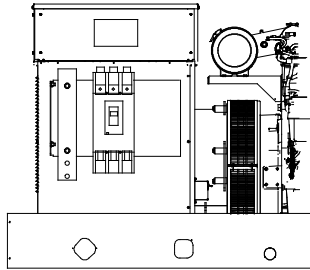

**Single Circuit Breaker Kit with Neutral Bus Bar
15-300 kW Model Shown**

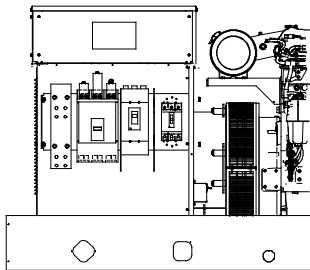

**Multiple Circuit Breaker Kit with Neutral Bus Bar
180-300 kW Model Shown**

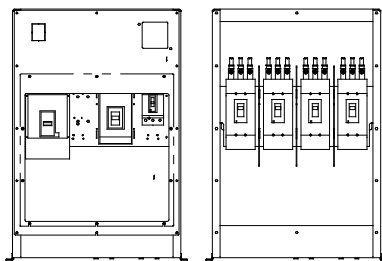

**Multiple Circuit Breaker Kits with Neutral Bus Bar
350-2250 kW Model Shown
(also applies to some 300 kW models)**

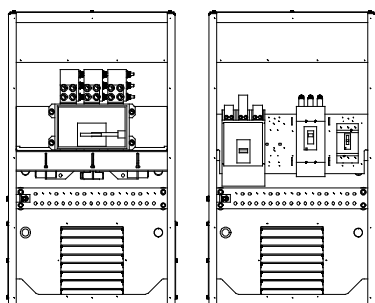

**Circuit Breaker Kits with Neutral Bus Bar
800-2500 kW KD Model Shown**

Standard Features

- The line circuit breaker interrupts the generator set output during a short circuit and protects the wiring when an overload occurs. Use the circuit breaker to manually disconnect the generator set from the load during generator set service.
- Circuit breaker kits are mounted to the generator set and are provided with load-side lugs and neutral bus bar.
- Kohler Co. offers a wide selection of molded-case line circuit breaker kits including single, dual, and multiple configurations for each generator set.
- Four types of line circuit breakers are available: (see page 2 for definitions and pages 3 and 4 for application details)
 - Magnetic trip
 - Thermal magnetic trip
 - **Electronic trip**
 - Electronic with ground fault (LSIG) trip
- In addition, line circuit breakers are offered with 80% and 100% ratings.
- Single line circuit breaker kits allow circuit protection of the entire electrical system load.
- Dual line circuit breaker kits allow circuit protection of selected priority loads from the remaining electrical system load.
- Multiple line circuit breaker kits with field connection barrier allow circuit protection for special applications (350- 2500 kW models and selected 80- 300 kW models).
- Up to four line circuit breakers can be used on 350- 2500 kW models.
- Line circuit breakers comply with the following codes and standards unless otherwise stated.
 - UL 489 Molded Case Circuit Breakers
 - UL 1077 Supplementary Protectors
 - UL 2200 Stationary Engine Generator Assemblies

Line Circuit Breaker Types

Magnetic Trip

The magnetic trip features an electromagnet in series with the load contacts and a moveable armature to activate the trip mechanism. When a sudden and excessive current such as a short circuit occurs, the electromagnet attracts the armature resulting in an instantaneous trip.

Thermal Magnetic Trip

Thermal magnetic trip contains a thermal portion with a bimetallic strip that reacts to the heat produced from the load current. Excessive current causes it to bend sufficiently to trip the mechanism. The trip delay is dependent on the duration and excess of the overload current. Elements are factory-calibrated. A combination of both thermal and magnetic features allows a delayed trip on an overload and an instantaneous trip on a short circuit condition.

Electronic Trip

These line circuit breakers use electronic controls and miniature current transformers to monitor electrical currents and trip when preset limits are exceeded.

LI breakers are a combination of adjustable trip functions including long-time ampere rating, long-time delay, and instantaneous pickup. LSI breakers have all of the LI breaker features plus short-time pickup, short-time delay, and defeatable instantaneous pickup. LSIG breakers have all of the LSI breaker features plus ground-fault pickup and delay.

NOTE: MG-frame does not have a long-time delay when selected with LI breakers.

Electronic with Ground Fault Trip

The ground fault trip feature is referred to as LSIG in this document. Models with LSIG compare current flow in phase and neutral lines, and trip when current unbalance exists.

Ground fault trip units are an integral part of the circuit breaker and are not available as field-installable kits. The ground fault pickup switch sets the current level at which the circuit breaker will trip after the ground fault delay. Ground fault pickup values are based on circuit breaker sensor plug only and not on the rating plug multiplier. Changing the rating plug multiplier has no effect on the ground fault pickup values.

80% Rated Circuit Breaker

Most molded-case circuit breakers are 80% rated devices. An 80% rated circuit breaker can only be applied at 80% of its rating for continuous loads as defined by NFPA 70. Circuit conductors used with 80% rated circuit breakers are required to be rated for 100% of the circuit breaker's rating.

The 80% rated circuit breakers are typically at a lower cost than the 100% rated circuit breaker but load growth is limited.

100% Rated Circuit Breaker

Applications where all UL and NEC restrictions are met can use 100% rated circuit breakers where 100% rated circuits can carry 100% of the circuit breaker and conductor current rating.

The 100% rated circuit breakers are typically at a higher cost than the 80% rated circuit breaker but have load growth possibilities.

When applying 100% rated circuit breakers, comply with the various restrictions including UL Standard 489 and NEC Section 210. If any of the 100% rated circuit breaker restrictions are not met, the circuit breaker becomes an 80% rated circuit breaker.

Line Circuit Breaker Options

Alarm Switch

The alarm switch indicates that the circuit breaker is in a tripped position caused by an overload, short circuit, ground fault, the operation of the shunt trip, an undervoltage trip, or the push-to-trip pushbutton. The alarm resets when the circuit breaker is reset.

Auxiliary Contacts

These switches send a signal indicating whether the main circuit breaker contacts are in the open or closed position.

Breaker Separators (350- 2500 kW)

Provides adequate clearance between breaker circuits.

Bus Bars

Bus bar kits offer a convenient way to connect load leads to the generator set when a circuit breaker is not present. **15- 300 kW.** Bus bar kits are available on alternators with leads for connection to the generator set when circuit breakers are not ordered.

350- 2500 kW. A bus bar kit is provided when no circuit breaker is ordered. Bus bars are also available in combination with circuit breakers or other bus bars on the opposite side of the junction box. On medium voltage (3.3 kV and above) units, a bus bar kit is standard (not applicable to KD models).

Field Connection Barrier

Provides installer wiring isolation from factory connections.

Ground Fault Annunciation

A relay contact for customer connection indicates a ground fault condition and is part of a ground fault alarm.

Lockout Device (padlock attachment)

This field-installable handle padlock attachment is available for manually operated circuit breakers. The attachment can accommodate three padlocks and will lock the circuit breaker in the OFF position only.

Lugs

Various lug sizes are available to accommodate multiple cable sizes for connection to the neutral or bus bar.

Overcurrent Trip Switch

The overcurrent trip switch indicates that the circuit breaker has tripped due to overload, ground fault, or short circuit and returns to the deenergized state when the circuit breaker is reset.

Shunt Trip, 12 VDC or 24 VDC

A shunt trip option provides a solenoid within the circuit breaker case that, when momentarily energized from a remote source, activates the trip mechanism. This feature allows the circuit breaker to be tripped by customer-selected faults such as alternator overload or overspeed. The circuit breaker must be reset locally after being tripped. Tripping has priority over manual or motor operator closing.

Shunt Trip Wiring

Connects the shunt trip to the generator set controller. (standard on KD models with the APM802 controller)

Undervoltage Trip, 12 VDC or 24 VDC

The undervoltage trips the circuit breaker when the control voltage drops below the preset threshold of 35%- 70% of the rated voltage.

15- 300* kW Line Circuit Breaker Specifications

* Includes models 300REOZJ and 300REZXC. For other 300 kW models, see the 300- 2250 kW section.

100% Rating Circuit Breaker

Alt. Model	Ampere Range	Trip Type	C. B. Frame Size	
4D/4E	15- 150	Thermal magnetic	HD	
		Electronic LI		
		Electronic LSI		
	60- 150	Electronic LSI		HG
		Electronic LSI		
		Electronic LSI		
4P/4PX 4Q/4QX	15- 150	Thermal magnetic	HD	
		Electronic LI		
		Electronic LSI		
	60- 150	Electronic LSI		HG
		Electronic LSI		
		Electronic LSI		
	175- 250	Thermal magnetic	JD	
		Electronic LI		
		Electronic LSI		
	250	Electronic LSI	JD	
				Electronic LSI
				Electronic LSI
		250	Electronic LI	JG
			Electronic LSI	
			Electronic LSI	
	400	Electronic LI	LG	
		Electronic LSI		
		Electronic LSI		
4RX 4S/4SX 4TX 4V 4UA 4M6226	15- 150	Thermal magnetic	HD	
		Electronic LI		
		Electronic LSI		
	60- 150	Electronic LSI		HG
		Electronic LSI		
		Electronic LSI		
	175- 250	Thermal magnetic	JD	
		Electronic LI		
		Electronic LSI		
	250	Electronic LSI	JD	
				Electronic LSI
				Electronic LSI
		250	Electronic LI	JG
			Electronic LSI	
			Electronic LSI	
	400	Electronic LI	LG	
		Electronic LSI		
		Electronic LSI		
600- 800	Electronic LSI	PG		
			Electronic LSI	
			Electronic LSI	
	1000- 1200	Electronic LSI	PG	
				Electronic LSI
		1200	Electronic LSI	PJ
Electronic LSI				

100% Rating Electrically Operated Breakers

For use as paralleling breakers with the Decision-Maker® 6000 Controller/DPS System or APM603 controller.

Generator-Mounted P-Frame, 24VDC Electrically Operated			
Alt. Model	Amps	Trip Unit	Frame
4RX 4S/4SX 4TX 4V	250	3.0 LI	PJ
	400	5.0 LSI	PJ
	600	3.0 LI	PL
	800	5.0 LSI	PL
4UA 4M6226	250	3.0 LI	PJ
	400	5.0 LSI	PJ
	600	3.0 LI	PL
	800	5.0 LSI	PL
	1200	5.0 LSI	PL

All circuit breakers listed in this table include line side bus and load side lugs, 24VDC motor operators, 2 type C auxiliary contacts, and 1 type C SDE overcurrent switch contact. No second breakers are allowed in combination with these breakers.

Interrupting Ratings

Circuit Breaker Frame Size	240 Volt, kA	480 Volt, kA	600 Volt, kA
HD	25	18	14
HG	65	35	18
HJ	100	65	25
JD	25	18	14
JG	65	35	18
JJ	100	65	25
LA	42	30	22
LG	65	35	18
MG	65	35	18
PG	65	35	18
PJ	100	65	25
PL	125	100	25

Circuit Breaker Lugs Per Phase (Al/Cu)

Frame Size	Ampere Range	Wire Range
E (480 V max.)	30- 100	Up to two wire terminals fitting 10-32 or 1/4-20 stud
H	15- 150	One #14 to 3/0
J	175	One 1/0 to 4/0
	200- 250	One 3/0 to 350 kcmil
LA	300- 400	One #1 to 600 kcmil or Two #1 to 250 kcmil
LG	400- 600	Two 2/0 to 500 kcmil AL/CU
M	800	Three 3/0 to 500 kcmil
	600-800	Three 3/0 to 500 kcmil
P	1000-1200	Four 3/0 to 500 kcmil
Mechanical Load Lugs Included with H, J, and LG LSI Neutrals		
H	60- 150	One #14 to 3/0 AL/CU
J	250	One 3/0 to 350 kcmil AL/CU
LG	400- 600	Two 4/0 to 500 kcmil AL/CU

15- 300* kW Line Circuit Breaker Applications

* Includes models 300REOZJ and 300REZXC. For other 300 kW models, see the 300- 2250 kW section.

Single Circuit Breaker Installations

A generator set with a single circuit breaker installed typically feeds a single transfer switch and then a distribution panel. This allows protection of the entire system.

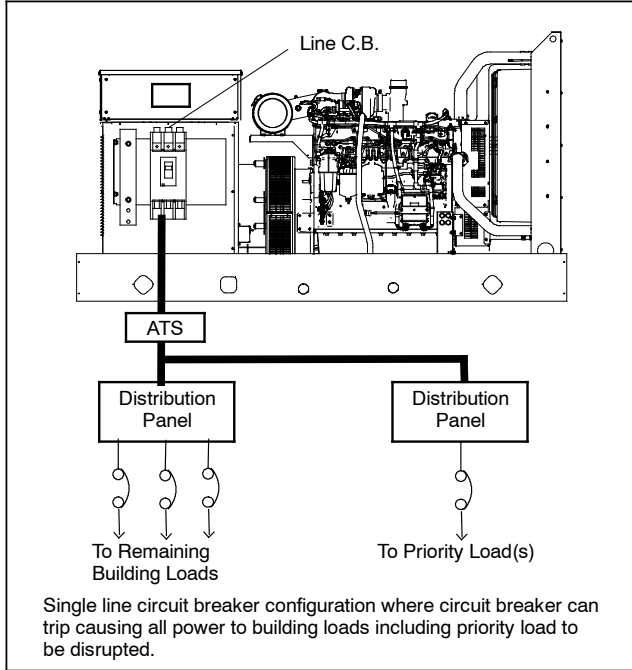

Multiple Circuit Breaker Installations

A generator set with dual circuit breakers installed is used to separate critical loads. Typically, one circuit breaker will feed a main transfer switch with noncritical loads and the other circuit breaker will feed a second transfer switch that feeds critical or priority loads. Multiple circuit breakers allow circuit protection for special applications.

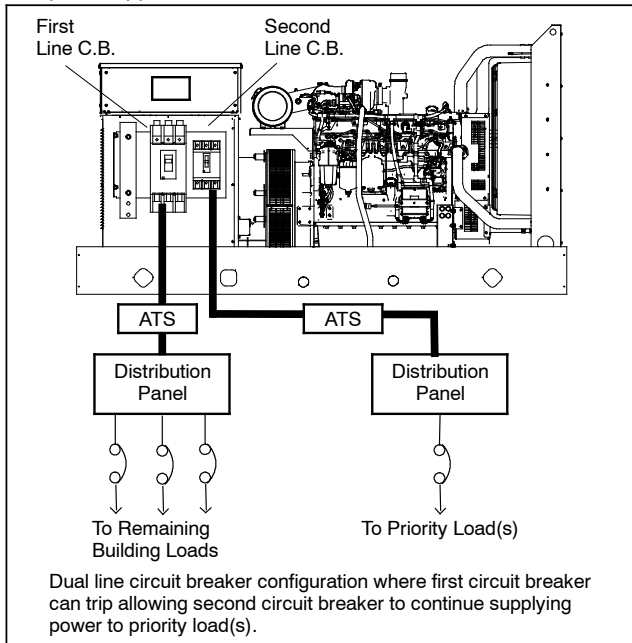

Circuit Breaker Combinations

Alternator Model	First C. B. Frame	Second C. B. Frame	Third C. B. Frame	Trip Type
ALL except 4D/4E	H	—	—	All
	J	—	—	
	LA	—	—	
	LG	—	—	
4D/4E	H	—	—	Standard or LSIG
	H	H	—	No LSIG
4P/4PX 4Q/4QX	H	H or J	—	No LSIG
	J		—	
	LA	—		
	LG	H, J or LG	—	
4RX 4S/4SX 4TX 4V	M	—	—	All
	P	—	—	All
	H or J	H or J	—	No LSIG
	LA	H, J, or LA	—	
	LG	H, J, LA, or LG	—	
	M		—	
	P	—	—	
H or J	H or J	H or J		
4UA 4M6226	M or P	—	—	All
	H or J	H or J	—	All
	LA	H, J, or LA	—	
	LG	H, J, LA, or LG	—	
	M or P	H, J, LA, or LG	—	
	P	P	—	
	H or J	H or J	H or J	
	LA	H or J	H or J	
		LA	H, J, or LA	
	LG	H or J	H or J	
LA		H, J, or LA		
M or P	LA	H, J, or LA		
	LG	H, J, or LG		

PowerPact™ H-, J-, and L-Frame Circuit Breakers Trip Curves

Figure 96: Micrologic 3.3S and 3.3S-W Electronic Trip Unit Long Time/Short Time Trip Curve

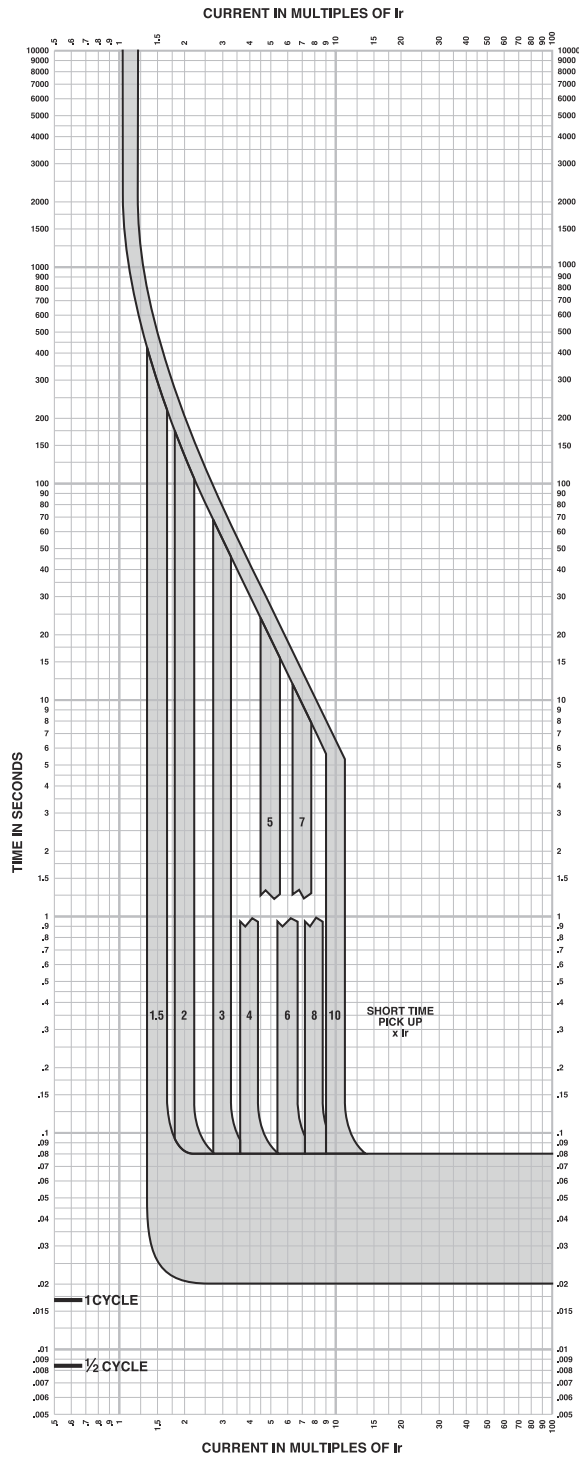

MICROLOGIC™ ELECTRONIC TRIP UNITS Micrologic™ 3.3S and 3.3S-W Long Time/Short Time Trip Curve 250A, 400A L-Frame

The time-current curve information is to be used for application and coordination purposes only.

Notes:

1. There is a thermal-imaging effect that can act to shorten the long-time delay. The thermal imaging effect comes into play if a current above the long-time delay pickup value exists for a time and then is cleared by the tripping of a downstream device or the circuit breaker itself. A subsequent overload will cause the circuit breaker to trip in a shorter time than normal. The amount of time delay reduction is inverse to the amount of time that has elapsed since the previous overload. Approximately 20 minutes is required between overloads to completely reset thermal-imaging.
2. Total clearing times shown include the response times of the trip unit, the circuit breaker opening, and the extinction of the current.

Curves apply from -35°C to +70°C (-31°F to +158°F) ambient temperature.



Typical Overall Dimensions

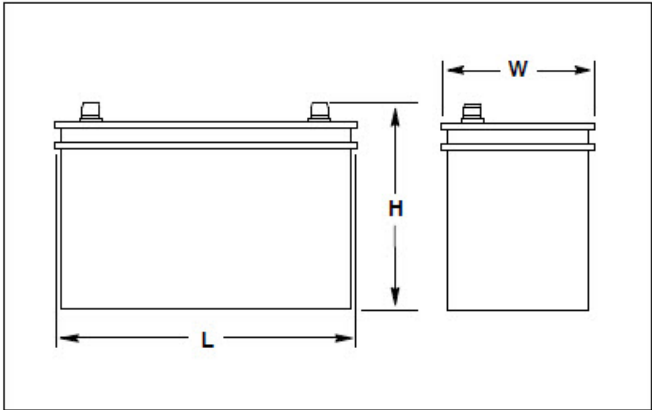

Standard Features

- Kohler Co. selects batteries to meet the engine manufacturer's specifications and to comply with NFPA requirements for engine-cranking cycles.
- Heavy-duty starting batteries are the most cost-effective means of engine cranking and provide excellent reliability in generator set applications.
- Tough polypropylene cases protect against life-shortening vibration and impact damage.
- Batteries are rated according to SAE standard J-537.
- All batteries are 12-volts. Kits that contain two or four batteries are available for 24-volt systems and/or systems with redundant starters.
- Wet- and dry-charged batteries have lead-calcium or lead-antimony plates and use sulfuric acid electrolyte. Removable cell covers allow checking of electrolyte specific gravity.
- Absorbant glass mat (AGM) batteries are sealed and maintenance free.
- Batteries are for applications below and above 0 ° C (32 ° F).

Charge Type*	Battery Part Number	Battery Qty. per Size	BCI Group Size	Battery SAE Dimension, mm (in.)			Cold Cranking Amps at 18°C (0°F) Min.	Reserve Capacity Minutes at 27° (80°F) Min.	Battery Post Layout and Style
				L	W	H			
Wet	256984	1	24	273.0 (10.8)	173.0 (6.8)	228.6 (9.0)	650	130	D/1

Battery Specifications

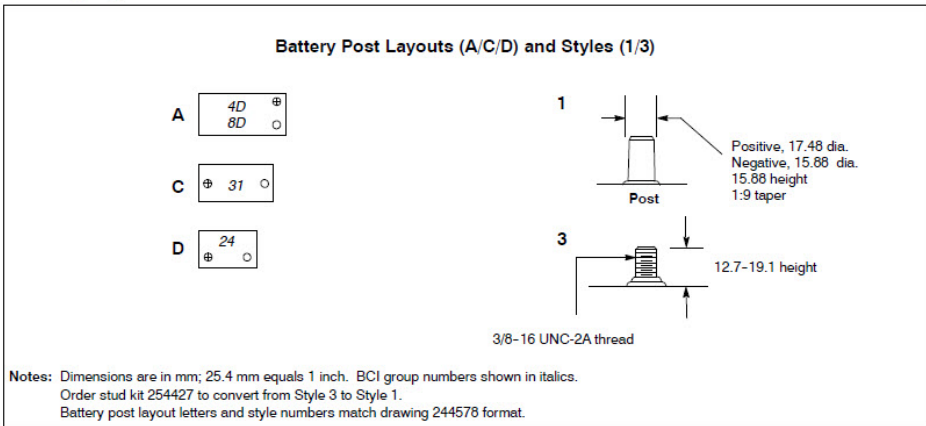

12/24 Volt, 10 Amp

Automatic Multi-Stage Battery Charger

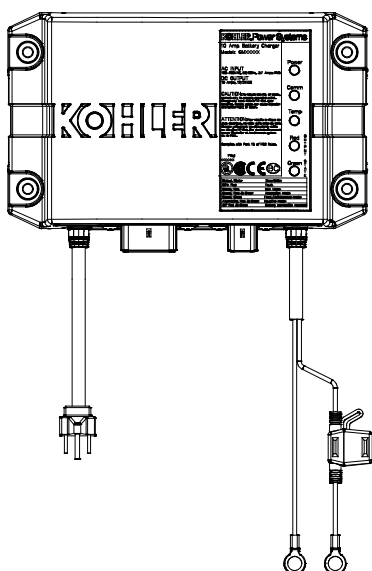

The battery charger is a fully-automatic, high efficiency battery charger that charges batteries rapidly and safely. The battery charger is designed for an industrial environment.

The battery charger is designed for operation with an engine cranking battery.

The battery charger is universal voltage input capable, comes with a standard 120 V/60 Hz AC plug, and charges 12 VDC or 24 VDC battery systems.

Five LED lights indicate power, communication status, temperature compensation status, charge curve, and charger status.

With the optional battery temperature sensor connected, the battery charger can adjust output voltages for optimal charging.

Standard Features

- 12 or 24 VDC output
 - Automatic voltage detection
- Automatic multi-stage charging modes
 - Recovery charge
 - Bulk charge
 - Absorption charge
 - Float charge
 - Equalize charge
- Charges the following type batteries:
 - Flooded lead acid (FLA)
 - AGM
 - Gel cell
 - High performance AGM
 - Nickel-cadmium (NiCad)
- 5 LED status indicators
- Durable potted assembly for waterproofing and vibration resistance
- Reverse-polarity protection
- Short-circuit protection
- Electronically limited output current
- Optional temperature compensation (FLA only)
- User adjustable parameters to support optimal manufacturer recommended charge curve.
- Code compliance:
 - UL 1236 Listed
 - NFPA 110, Level 1 compatible (when used with Kohler controller and connected to engine harness)
 - CSA - C22.2 No. 107.2-01
 - FCC - Title 47, Part 15 Class A
 - CE
 - IBC 2015
 - OSHPD

DC Output		AC Input		Overall Dimensions W x D x H	Shipping Weight	
Volts (Nominal)	Amps	Volts (Nominal)	Amps		kgs	lbs
12/24	10	100-260	3.7	253 mm x 152 mm x 74 mm (10.0 in x 6.0 in x 2.9 in)	3.6	7.9

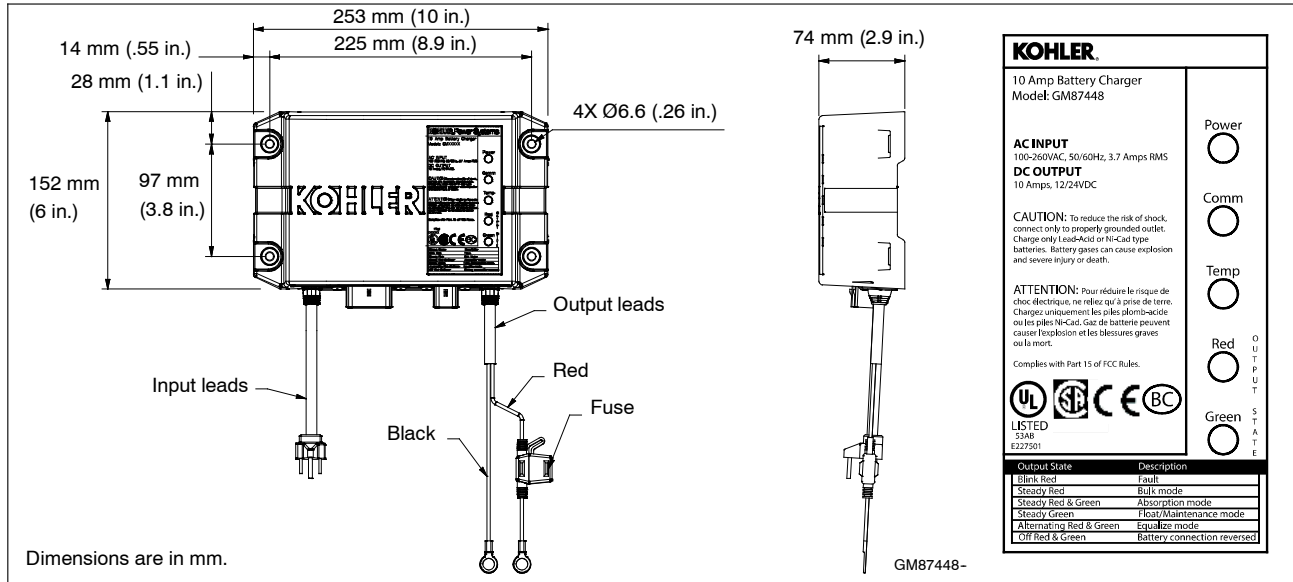

Specifications

AC Input	100-260 VAC
Frequency Input	50/60 Hz
DC Output	10 Amps @ 12 VDC or 10 Amps @ 24 VDC (On battery voltage regulation $\pm 1\%$; current is electronically limited)
Fuse Protection	15 amps ATC
Battery Types	Flooded Lead Acid (FLA) AGM Gel Cell High Performance AGM Nickel-Cadmium (NiCad)
Monitoring LED Indications	Power Communication Temperature compensation Output charger curve and charger status: <ul style="list-style-type: none"> ○ Red ○ Green
Environmental	
Operating	-20° to 70°C (-4° to 158° F)
Storage	-40° to 85°C (-40° to 185° F)
Relative Humidity	5 to 95% (non-condensing)
Salt Spray Testing	ASTM B117
Corrosion Resistant	From battery gases

Enclosure	
Environmental Resistant	From rain, snow, dust, and dripping water
Battery Connections	
Lead Length	1.8 m (6 ft.) red and black leads
Battery Connections	9.5 mm (3/8 in.) ring terminals
AC Power Connections	
Lead Length	1.8 m (6 ft.)
Storage	Standard US style 3-prong AC plug
Available Options	
Temperature compensation	

DISTRIBUTED BY:

Availability is subject to change without notice. Kohler Co. reserves the right to change the design or specifications without notice and without any obligation or liability whatsoever. Contact your local Kohler® generator distributor for availability.

© 2017, 2019 by Kohler Co. All rights reserved.

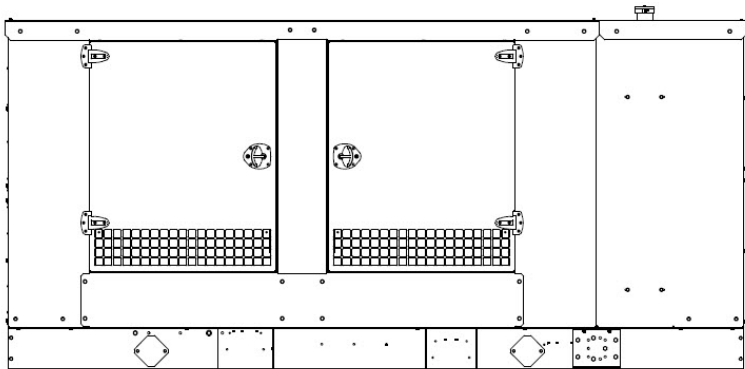

KG80-125

Sound Enclosure Standard Features

- Internal-mounted critical silencer and flexible exhaust connector.
- Skid-mounted, steel construction with hinged doors.
- Fade-, scratch-, and corrosion-resistant Kohler® Power Armor automotive-grade textured finish.
- Enclosure has four access doors which allow for easy maintenance.
- Lockable, flush-mounted door latches.
- Vertical air inlet and outlet discharge to redirect air and reduce noise.
- Steel sound enclosure has a 241 kph (150 mph) wind loading
- Sound attenuated enclosure that uses up to 51 mm (2 in.) of acoustic-lined air discharge hood.

Weather and Sound Enclosure

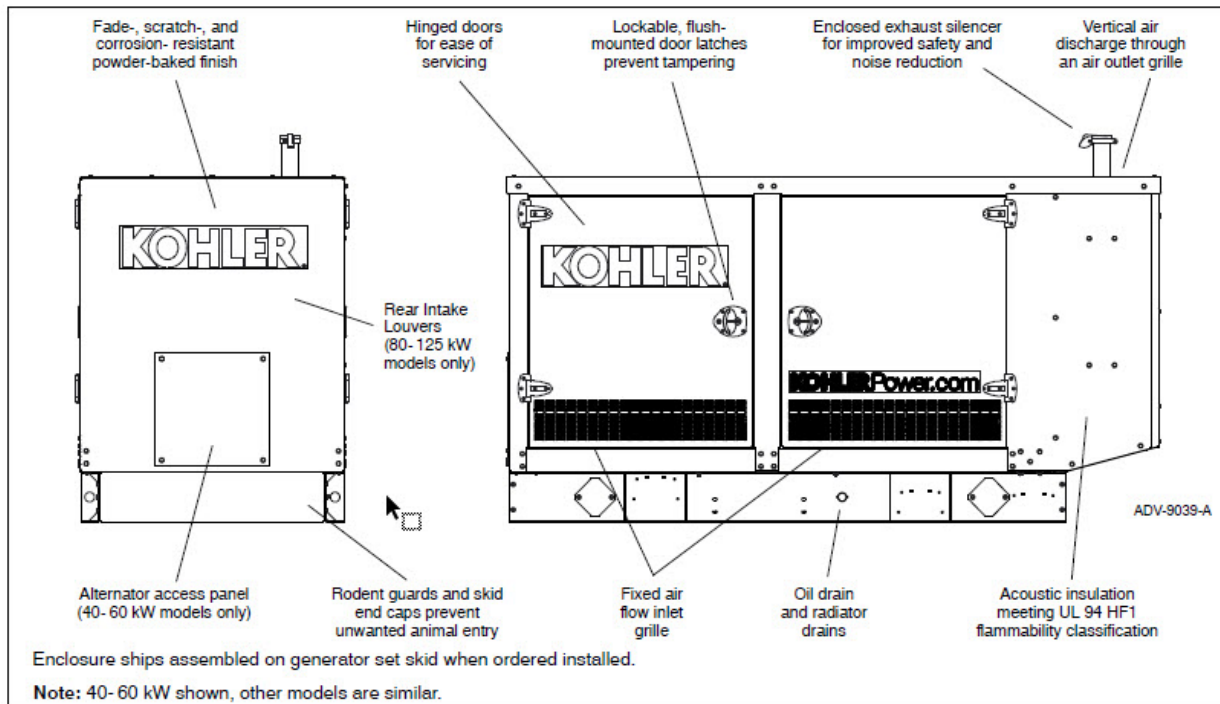

Sound Enclosure Features

- Available in steel (14 gauge) formed panel, solid construction. Preassembled package offering corrosion resistant, dent resilient structure that mounts directly to lift base or fuel tank.
- Power Armor automotive-grade finish resulting in advanced corrosion and abrasion protection as well as enhanced edge coverage and color retention.
- Internal critical exhaust silencer offering maximum component life and operator safety.
- Interchangeable modular panel construction. Allows complete serviceability or replacement without compromising enclosure design.
- Cooling/combustion air intake with a horizontal air inlet. Sized for maximum cooling airflow.
- Service access. Multi-personnel doors for easy access to generator set control and servicing of the oil fill and battery.
- Cooling air discharge, The sound enclosures include acoustic insulation with urethane film.
- Sound attenuating design. Mechanically restrained acoustic insulation UL 94 HF1 listed for flame resistance.
- Enclosed critical silencer and three-way catalyst standard on KG100 and KG125 (optional on KG80)

Fuel Tank Capacity, L (gal.)	Est. Fuel Supply Hours at 60 Hz with Full Load	Max. Length, mm (in.)	Max. Width, mm (in.)	Sound Pressure Level, dB(A)	Max. Height, mm (in.)	Weight, kg (lb.)
Lift base	0	3525 (138.8)	1154 (45.4)	69	1713 (67.4)	1616 (3562)

Note: Data in table is for reference only, refer to the respective ADV drawings for details.

Max. weight includes the generator set (wet) with largest alternator option, enclosure, and silencer.

Log average sound pressure level of 8 measured positions around perimeter of the unit at a distance of 7 m (23 ft). Refer to TIB-114 for details.

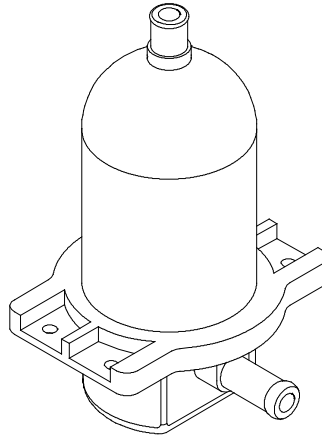

Block Heater Kit, typical

Applicable Models

- **KG40- KG125**
- KG150- KG200
- KG150R
- 25- 45REZG
- 25- 60REZGB
- 50REZGC/125REZGC/150REZGC
- 50- 60REOZJD
- 50REOZJE
- 80REZGD/100REZGD
- 80RZGD/100RZGD
- 80- 200REOZJF
- 80- 150REOZJG4
- 125RZGC/150RZGC
- 125REOZJG/180REOZJG

Standard Features

- UL- C/US listed
- CE compliant
- Controls for automatic operation
- Compact design
- Easy to install

Description

The engine block heater kit heats the engine coolant in cold ambient, warming the cylinders, oil, and charge air circuit which all help to give a faster starting time. The engine block heater uses thermosiphon action to circulate warm coolant into the engine and supplies constant heating to the engine. The engine block heater kit helps to extend element life and gives a significant reduction in electrical consumption.

The engine block heater kit is recommended for ambient temperatures below 10°C (50°F).

The engine block heater kits are available in 120 V, 240 V, and 277 V versions.

Block Heater Specifications

Heating Fluid	Water, Coolant Mix (50% Glycol/50% Water)
Max. Pressure	90 psi (620 kPa)
Heating Element Material	Incoloy 800
Inlet/Outlet Plumbing	0.625 in. hose barb
System Ingress	IP41
Power Connection	NEMA Plug and EURO Plug
Power Chord Length	48 in. (1219 mm)

Specifications

Block Heater Kit Number	Component	Watts	Voltage	Phase	Thermostat Temperature	
					ON	OFF
GM58098- KA1	358311	1000	120	1	27°C (80°F)	38°C (100°F)
GM75536- KA1	326228	1500	120	1	49°C (120°F)	60°C (140°F)
GM75555- KA5	GM75552	1800	120	1	27°C (80°F)	38°C (100°F)
GM75555- KA6	GM75553	2000	240	1		
GM75556- KA1	352945	1500	120	1		
GM75557- KA1	352945	1500	120	1		
GM75564- KA1	358311	1000	120	1		
GM75565- KA1	352945	1500	120	1		
GM77944- KA1	352945	1500	120	1		
GM77944- KA2	352946	1500	240	1		
GM85060- KA1	GM75552	1800	120	1		
GM85060- KA2	GM75553	2000	240	1		
GM89427- KA2	GM75552	1800	120	1		
GM91708- KA1	352945	1500	120	1		
GM94248- KA1	352945	1500	120	1		
GM104799- KA1	352945	1500	120	1		
GM105165- KA1	352945	1500	120	1		
GM105165- KA2	352946	1500	240	1		
GM105409- KA1	352945	1500	120	1		
GM105409- KA2	352946	1500	240	1		



Integral Voltage Regulator with Kohler® APM402/ Decision-Maker® 3000 and Menu-Driven Selections (15-1000 kW Generator Set Models)

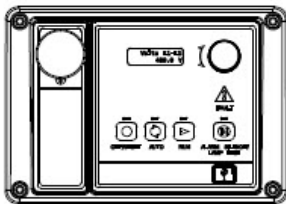

APM402 and Decision-Maker® 3000 Controller with Integral Voltage Regulator

The voltage regulator is integral to the controller and uses patented hybrid voltage regulator design providing ±0.5% no-load to full-load regulation using root-mean-square (RMS) voltage sensing. The voltage regulator features three-phase sensing and is available for 12- or 24-volt engine electrical systems.

Voltage Regulators

The following information provides general features, specifications, and functions of available voltage regulators.

This information generally applies to a single generator set and multiple generator sets with paralleling applications. Refer to the respective generator set specification sheet and see your authorized distributor for information regarding specific voltage regulator applications and availability.

Integral Voltage Regulators with APM402/Decision-Maker® 3000 Controllers

Calibration	Digital Display	Range Settings	Default Selection
Voltage Adjustment	Volt Adj	± 10% of System Voltage	System Voltage
Underfrequency Unload or Frequency Setpoint	Frequency Setpoint	42 to 62 Hz	2.5 Hz Below Nominal Frequency
Underfrequency Unload Scope	Slope	0-10% of System Voltage (Volts per Cycle)	5% of System Voltage



Specification/Feature	Integral with APM402/Decision-Maker® 3000
Generator Set Availability	15-1000 kW
Type	Patented Hybrid Design
Status and Shutdown Indicators	LEDs and Text LCD Display
Operating Temperature	-40 ° C to 70 ° C (-40 ° F to 158 ° F)
Storage Temperature	-40 ° C to 85 ° C (-40 ° F to 185 ° F)
Humidity	5-95% Non-Condensing
Circuit Protection	Solid-State, Redundant Software and Fuses
Sensing, Nominal	100-240 Volts (L-L), 50-60 Hz
Sensing Mode	RMS, Single- or 3-Phase
Input Requirements	8-36 VDC
Continuous Output	5 VDC @ 100mA max. 5.0 ADC with GM88453 Activator Board
Maximum Output	5 VDC @ 100mA max. 5.0 ADC with GM88453 Activator Board
Transition Frequency	42.0-62.0Hz
Exciter Field Resistance	4-30 Ohms with GM88453 Activator Board
No-Load to Full-Load Voltage Regulation	± 0.5%
Thermal Drift	<0.5% (-40 ° C to 70 ° C) [-40 ° F to 158 ° F] Range
Response Time	Less than 5µS
System Voltage Adjust.	± 10%
Voltage Adjustment	Controller Menu Knob
Remote Voltage Adjustment	not available
Paralleling Capability	not available
VAR/PF Control Input	not available

Integral Voltage Regulator with APM402/Decision-Maker® 3000 Controller

- The APM402/Decision-Maker® 3000 digital display and pushbutton/rotary dial provide access to data. A two-line LCD display provides complete and concise information. A two-line vacuum fluorescent display provides complete and concise information.
- The Decision-Maker® 3000 graphical display and pushbutton/rotary dial provide access to data. A five-line, 35-characters per line LCD display provides complete and concise information include gain, ramp rate, reactive droop, VAR control (P, I, D gains) and PF control (P, I, D gains).
- The controllers provide ISO 8528-5, Class G3, compliance for transient response on some 20-300 kW generator set models. Both controllers support Modbus®.
- These controllers can control Fast Response™ II, Fast Response™ X, and wound field alternators using the GM88453 activator board.

Voltage Regulator Menu

- Voltage adjustment, ± 10% of system voltage
- V/Hz cut-in, 42-62 Hz
- Underfrequency unload slope, 0-10% of system voltage

Jumpers

- L1-L2 volts
- L2-L3 volts (3-phase)
- L3-L1 volts (3-phase)
- L1-N volts
- L2-N volts
- L3-N volts (3-phase)

KOHLER®

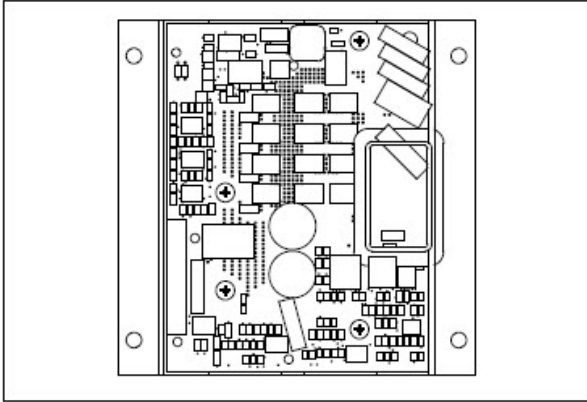

- Interfaces between the controller and alternator assembly using rotor field leads, auxiliary power windings, and optic board leads.
- Allows the Decision-Maker® controllers the ability to control a wound-field alternator using the same control signal as Fast Response™ alternator.
- Permits the generator set controller to control the current to the exciter field of a wound-field excited alternator.
- Contains two isolated relay driver outputs (RDO) rated at 250 mA. Provides RDO outputs indicating a field over-excitation condition and that the alternator is supplying voltage to the activator.

Modbus® is a registered trademark of Schneider Electric.

Remote Serial Annunciator III (RSA III)

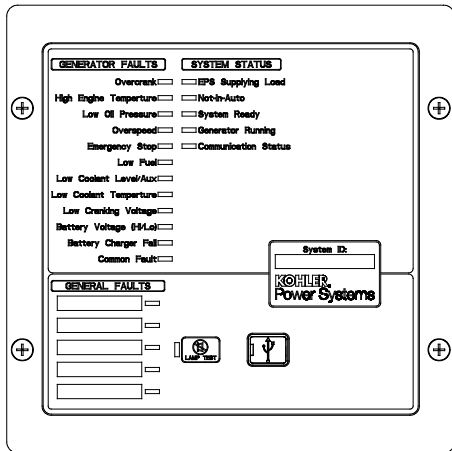

RSA III

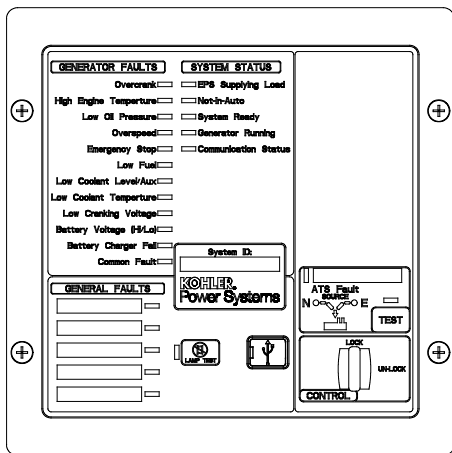

RSA III with a Single ATS Control

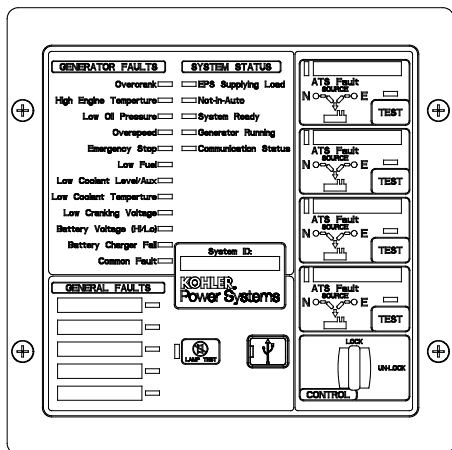

RSA III with Four ATS Controls

Remote Serial Annunciator III (RSA III) for Kohler® Controllers

- Monitors the generator set equipped with one of the following controllers:

APM402	Decision-Maker® 3000
APM603	Decision-Maker® 3500
APM802	Decision-Maker® 6000
Decision-Maker® 3+	Decision-Maker® 8000
Decision-Maker® 550	KPC 1000
- Allows monitoring of the common alarm, remote testing of the automatic transfer switch, and monitoring of the normal/emergency source for up to four ATS with any of the following controllers:

Decision-Maker®	MPAC® 750, 1200, and 1500
MPAC®	1000 and 1500
- Configuration via a personal computer (PC) software.
- Writable surfaces (white boxes in illustrations) for user-defined selections.
- Uses Modbus® RTU protocol.
- Controller connections:
 - RS-485 for serial bus network
 - USB port. Connect a personal computer and use Kohler® SiteTech™ software to view events and adjust settings. *
 - 12-/24-volt DC power supply
 - 120/208 VAC power supply (available accessory)
- Meets the National Fire Protection Association Standard NFPA 110, Level 1.

Dimensions

- Dimensions—W x H x D, mm (in.).

Surface Mounted:

203 x 203 x 83 (8.0 x 8.0 x 3.3)

Flush Mounted (Inside Wall):

203 x 203 x 76 (8.0 x 8.0 x 3.0)

Flush mounting plate W1: 254 (10.0)

* SiteTech™ software is available to Kohler authorized distributors and dealers.

Modbus® is a registered trademark of Schneider Electric.

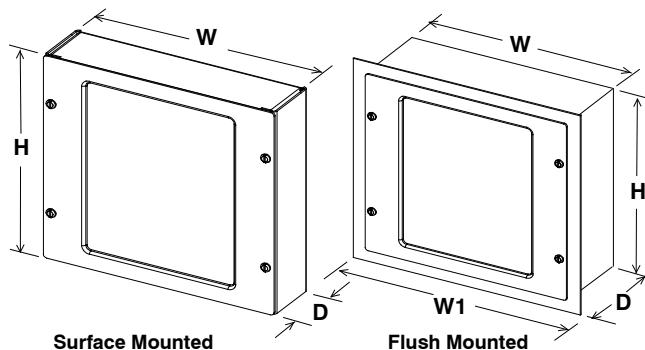

Fault and Status Conditions	Fault LEDs	Fault Horn	System Ready LED	Generator Running LED	Communication Status LED
Overcrank Shutdown	Red	On	Red	Off	Green
High Engine Temperature Warning *	Yellow	On	Red	Green	Green
High Engine Temperature Shutdown	Red	On	Red	Off	Green
Low Oil Pressure Warning *	Yellow	On	Red	Green	Green
Low Oil Pressure Shutdown	Red	On	Red	Off	Green
Overspeed Shutdown	Red	On	Red	Off	Green
Emergency Stop *	Red	On	Red	Off	Green
Low Coolant Level/Aux. Shutdown	Red	On	Red	Off	Green
Low Coolant Temperature *	Yellow	On	Red	Off	Green
Low Cranking Voltage	Yellow	On	Red	Off	Green
Low Fuel—Level or Pressure *	Yellow	On	Red	Green or Off	Green
Not-In-Auto	Red	On	Red	Green or Off	Green
Common Fault	Red	On	Green	Green or Off	Green
Battery Charger Fault (1) *	Yellow	On	Red	Green or Off	Green
Battery Charger Fault (2) *	Yellow	On	Green	Green or Off	Green
High Battery Voltage *	Yellow	Off	Green	Green or Off	Green
Low Battery Voltage *	Yellow	Off	Green	Green or Off	Green
User Input #1 (Warning)	Yellow	Off	Green	Green or Off	Green
User Input #1 (Shutdown)	Red	On	Green	Off	Green
User Input #2 (Warning)	Yellow	Off	Green	Green or Off	Green
User Input #2 (Shutdown)	Red	On	Green	Off	Green
User Input #3 (Warning) (1) †	Yellow	Off	Green	Green or Off	Green
User Input #3 (Shutdown) (1) †	Red	On	Green	Off	Green
User Input #4 (Warning) (1)	Yellow	Off	Green	Green or Off	Green
User Input #4 (Shutdown) (1)	Red	On	Green	Off	Green
User Input #5 (Warning) (1)	Yellow	Off	Green	Green or Off	Green
User Input #5 (Shutdown) (1)	Red	On	Green	Off	Green
EPS Supplying Load	Yellow	Off	Green	Green	Green
Communications Status (Fault mode)	—	Off	Green or Red	Green or Off	Red
ATS Fault (RSA III with ATS Controls only)	Red	On	Red or Yellow	Green or Off	Green

Green LEDs appear as steady on when activated.

Yellow LEDs slow flash when activated except steady on with EPS supplying load and high battery voltage.

Red LEDs slow flash when activated except fast flash with loss of communication and not-in-auto.

Specifications

- LED indicating lights for status, warning, and/or shutdown.
- Power source with circuit protection: 12- or 24-volt DC
- Power source with 120/208 VAC, 50/60 Hz adapter (option)
- Power draw: 200 mA
- Humidity range: 0% to 95% noncondensing
- Operating temperature range: -20°C to +70°C (-4°F to +158°F)
- Storage temperature range: -40°C to +85°C (-40°F to +185°F)
- Standards:
 - NFPA 110, level 1
 - UL 508 recognized
 - CE directive
 - NFPA 99
 - ENS 61000-4-4
 - EN611-4-4 fast transient immunity
- RS-485 Modbus® isolated port @ 9.6/19.2/38.4/57.6 kbps (default is 19.2 kbps)
- USB device port
- NEMA 1 enclosure

(1) All generator set controllers except Decision-Maker® 3+ controller.

(2) Decision-Maker® 3+ controller only.

* May require optional kit or user-provided device to enable function and LED indication.

† Digital input #3 is factory-set for high battery voltage on the Decision-Maker® 3+ controller.

Modbus® is a registered trademark of Schneider Electric.

NFPA Requirements

- NFPA 110 compliant
- Engine functions:
 - High battery voltage warning *
 - High engine temperature shutdown
 - High engine temperature warning *
 - Low battery voltage warning *
 - Low coolant level/aux. shutdown
 - Low coolant temperature warning *
 - Low cranking voltage
 - Low fuel warning (level or pressure) *
 - Low oil pressure shutdown
 - Low oil pressure warning *
 - Overcrank shutdown
 - Overspeed shutdown
- General functions:
 - Audible alarm silence
 - Battery charger fault *
 - Lamp test
 - Master switch not-in-auto

Fault and Status LEDs and Lamp Test Switch

Alarm Horn. Horn sounds giving a minimum 90 dB at 0.1 m (0.3 ft.) audible alarm when a warning or shutdown fault condition exists except on high/low battery voltage or EPS supplying load.

Alarm Silenced. Red LED on lamp test switch lights when alarm horn is deactivated by alarm silence switch.

Alarm Silence Switch. Lamp test switch quiets the alarm during servicing. The horn will reactivate upon additional faults.

ATS Fault. Red LED lights when ATS fails to transfer.

Battery Charger Fail. LED lights if battery charger malfunctions. Requires battery charger with alarm contact.

Battery Voltage Hi/Lo. LED flashes if battery or charging voltage drops below preset level. LED lights steady if battery voltage exceeds preset level.

Common Fault. LED lights when a single or multiple common faults occur.

Communication Status. Green LED lights indicating annunciator communications functional. Red LED indicates communication fault.

EPS Supplying Load. LED lights when the Emergency Power System (EPS) generator set is supplying the load (APM402, APM603, APM802, and Decision-Maker® 550, 3000, 3500, 6000, and 8000 controllers) or when transfer switch is in the emergency position (Decision-Maker® 3+ controller).

Emergency Stop. LED lights and engine stops when emergency stop is made. May require a local emergency stop switch on some Decision-Maker® 3+ controllers.

Generator Running. LED lights when generator set is in operation.

High Engine Temperature. Red LED lights if engine has shut down because of high engine coolant temperature. Yellow LED lights if engine coolant temperature approaches shutdown range. Requires warning sender on some models.

Lamp Test (Switch). Switch tests all the annunciator indicator LEDs and horn.

Low Coolant Level/Aux. LED lights when engine coolant level is below acceptable range on radiator-mounted generator sets only. When used with a Decision-Maker® 3+ controller, the LED indicates low coolant level or an auxiliary fault shutdown. Requires user-supplied low coolant level switch on remote radiator models.

Low Coolant Temperature. LED lights if optional engine block heater malfunctions and/or engine coolant temperature is too low. Requires prealarm sender on some models.

Low Cranking Voltage. LED lights if battery voltage drops below preset level during engine cranking.

Low Fuel (Level or Pressure). LED lights if fuel level in tank approaches empty with diesel models or fuel pressure is low on gas models. Requires customer-supplied switch.

Low Oil Pressure. Red LED lights if generator set shuts down because of insufficient oil pressure. Yellow LED lights if engine oil pressure approaches shutdown range. Requires warning sender on some models.

Not In Auto. LED lights when the generator set controller is not set to automatic mode.

Overcrank. LED lights and cranking stops if engine does not start in either continuous cranking or cyclic cranking modes.

Overspeed. LED lights if generator set shuts down because of overspeed condition.

System Ready. Green LED lights when generator set master switch is in AUTO position and the system senses no faults. Red LED indicates system fault.

User-Defined Digital Inputs #1-#5. Monitors five digital auxiliary inputs (can be configured as warnings or shutdowns). User-defined digital inputs are selected via the RSA III master for local or remote (generator set or ATS). The user-defined digital input can be assigned via PC using SiteTech™ setup software.

KOHLER®

Alternator Data

TECHNICAL INFORMATION BULLETIN

Alternator Data Sheet

Alternator Model: 4R9X
Frequency: 60 Hz
Speed: 1800 RPM
Leads: 12 (6 Lead, 600 Volt)

Voltage L-N/L-L	Phase	Power Factor	Connection	kW* (kVA)						
				Class B		Class F			Class H	
				80°C Continuous	90°C Lloyds	95°C ABS	105°C Continuous	130°C Standby	125°C Continuous	150°C Standby
139/240 277/480	3	0.8	Wye	84.0 (105.0)	88.5 (110.5)	90.5 (113.0)	95.0 (118.5)	103.0 (128.5)	101.5 (126.5)	109.5 (136.5)
127/220 254/440	3	0.8	Wye	83.0 (103.5)	87.5 (109.0)	89.5 (111.5)	93.5 (116.5)	101.5 (126.5)	100.0 (125.0)	108.0 (135.0)
120/208 240/416	3	0.8	Wye	82.0 (102.5)	86.0 (107.5)	88.0 (110.0)	92.0 (115.0)	100.5 (125.5)	98.5 (123.0)	106.5 (133.0)
110/190 220/380	3	0.8	Wye	74.5 (93.0)	78.0 (97.5)	80.0 (100.0)	84.5 (105.5)	91.5 (114.0)	89.5 (111.5)	96.5 (120.5)
120/240	3	0.8	Delta	82.0 (102.5)	86.0 (107.5)	88.0 (110.0)	92.0 (115.0)	100.5 (125.5)	98.5 (123.0)	106.5 (133.0)
120/240	1	1.0	Dogleg	64.5 (64.5)	67.5 (67.5)	68.5 (68.5)	71.0 (71.0)	77.5 (77.5)	76.5 (76.5)	82.5 (82.5)
347/600	3	0.8	Wye	83.5 (104.0)	88.0 (110.0)	90.0 (112.5)	94.5 (118.0)	102.5 (128.0)	101.0 (126.0)	109.0 (136.0)

* All data tested in accordance with IEEE Standard 115. Kohler Co. reserves the right to change the design or specifications without notice and without any obligation or liability whatsoever.

Submittal Data: 139/240 Volts, 0.8 PF, 1800 RPM, 60 Hz, 3 Phase, 130°C Rise

	Symbol	PerUnit	Ohms		Symbol	Value
Typical Cold Resistances				Typical Time Constants		
Phase Resistance		0.036	0.016	Armature Short Circuit	T _a	0.007 sec.
Rotor Resistance		16.96	7.585	Transient Short Circuit	T' _d	0.065 sec.
Typical Reactances				Transient Open Circuit	T' _{do}	0.748 sec.
Synchronous				Typical Field Current		
Direct	X _d	2.969	1.328	Full Load	I _{fFL}	21.6 amps
Quadrature	X _q	1.523	0.681	No Load	I _{fNL}	5.6 amps
Transient				Typical Short Circuit Ratio		0.337
Unsaturated	X' _{du}	0.292	0.131	Harmonic Distortion		
Saturated	X' _d	0.257	0.115	RMS Total Harmonic Distortion		3.20%
Subtransient				Max. Single Harmonic		5th
Direct	X'' _d	0.123	0.055	Deviation Factor (No Load, L-L)		<5%
Quadrature	X'' _q	0.114	0.051	Telephone Influence Factor		<50
Negative Sequence	X ₂	0.118	0.053	Insulation Class		
Zero Sequence	X ₀	0.011	0.005	per NEMA MG1-1.66		H
				Phase Rotation		ABC

**4R9X, 60 Hz, 139/240, 277/480 Volts, Wye
TYPICAL ALTERNATOR EFFICIENCY***

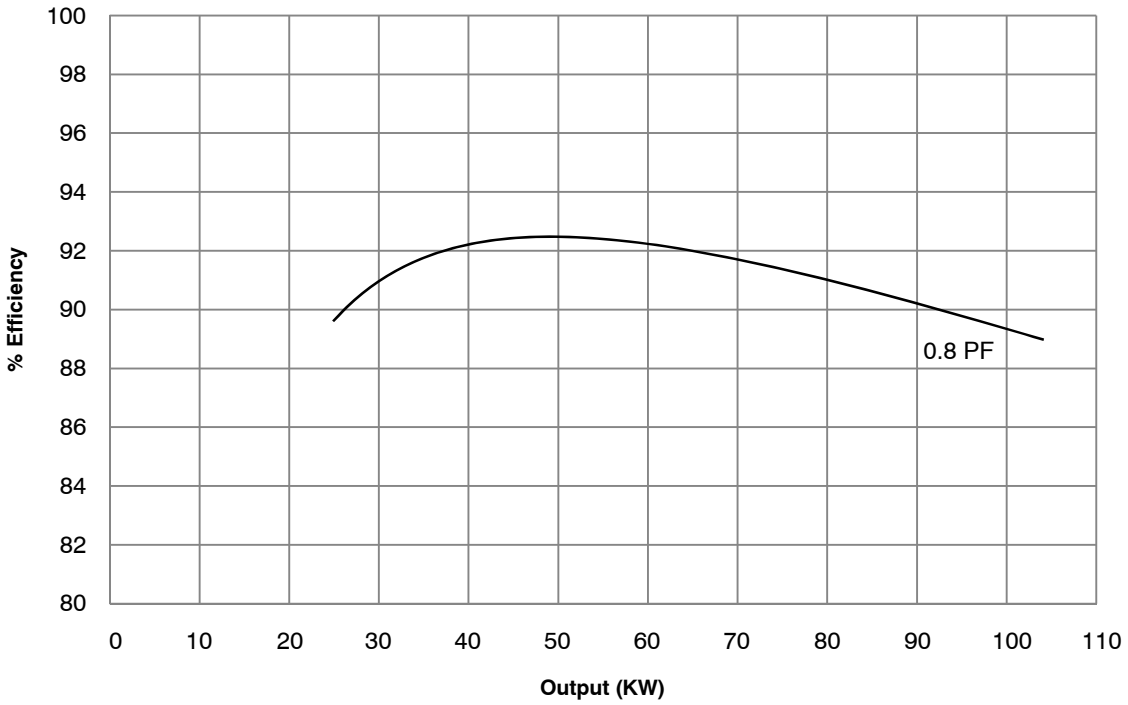

**4R9X, 60 Hz, 139/240, 277/480 Volts, Wye
TYPICAL MOTOR STARTING CHARACTERISTICS***

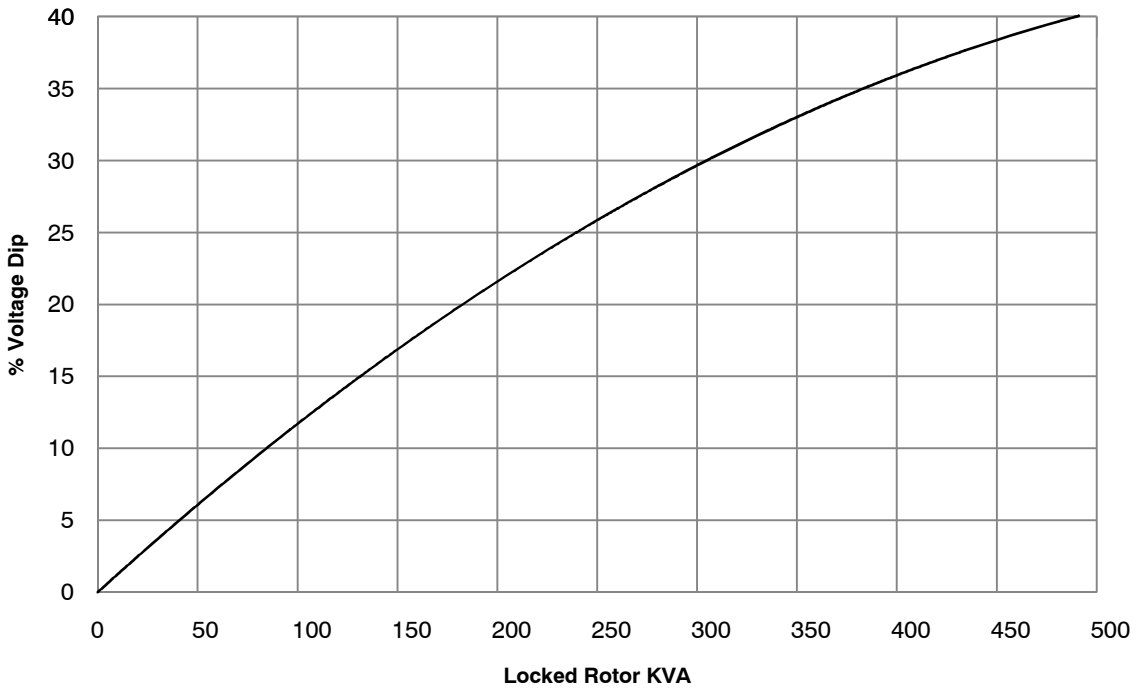

* All data tested in accordance with IEEE Standard 115. Kohler Co. reserves the right to change the design or specifications without notice and without any obligation or liability whatsoever.

**4R9X, 60 Hz, Low Wye or Delta Connection
SHORT CIRCUIT DECREMENT CURVE**

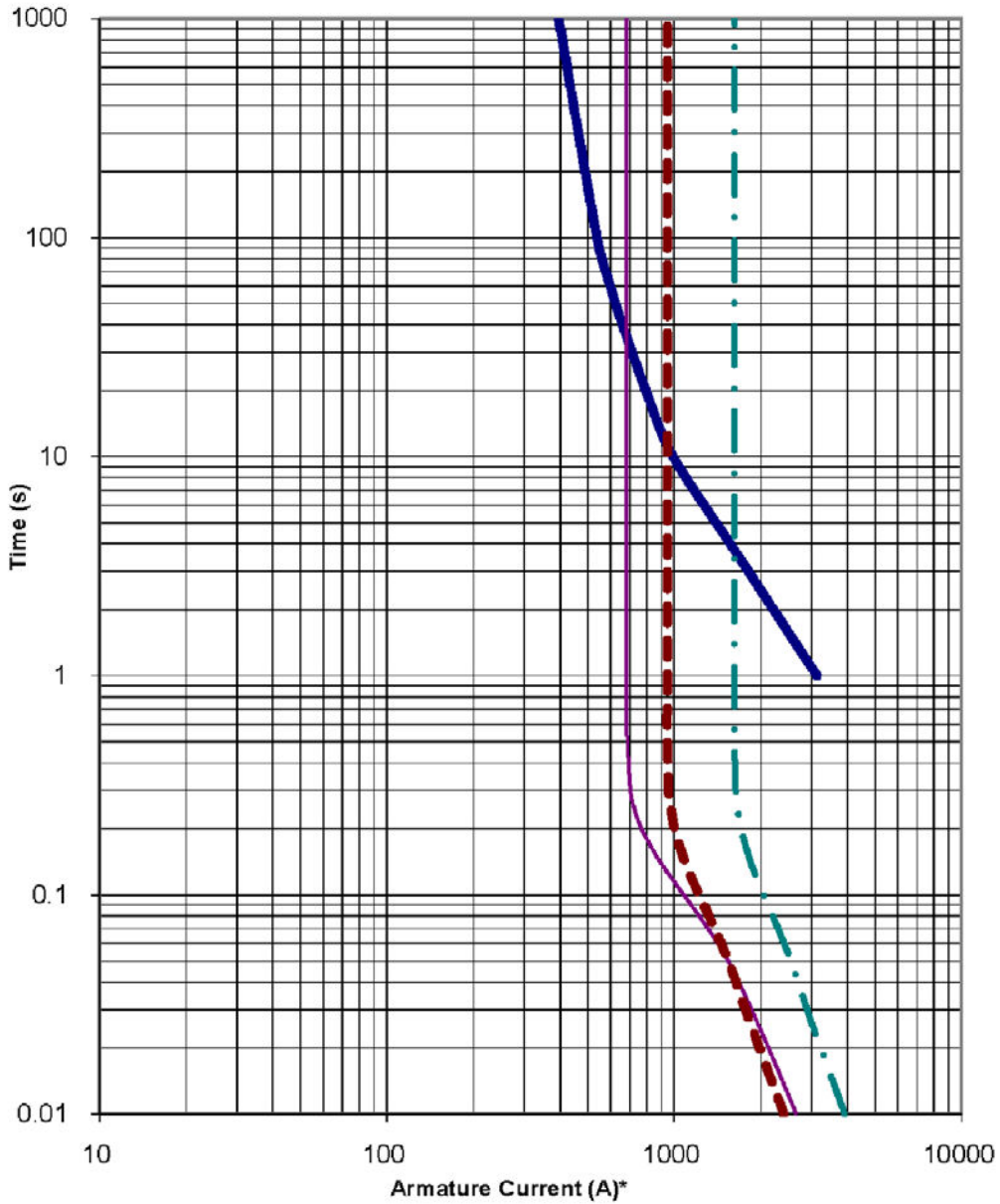

*Instantaneous current (t=0) is asymmetric. Divide by 1.73 for symmetric.

**4R9X, 60 Hz, High Wye Connection
SHORT CIRCUIT DECREMENT CURVE**

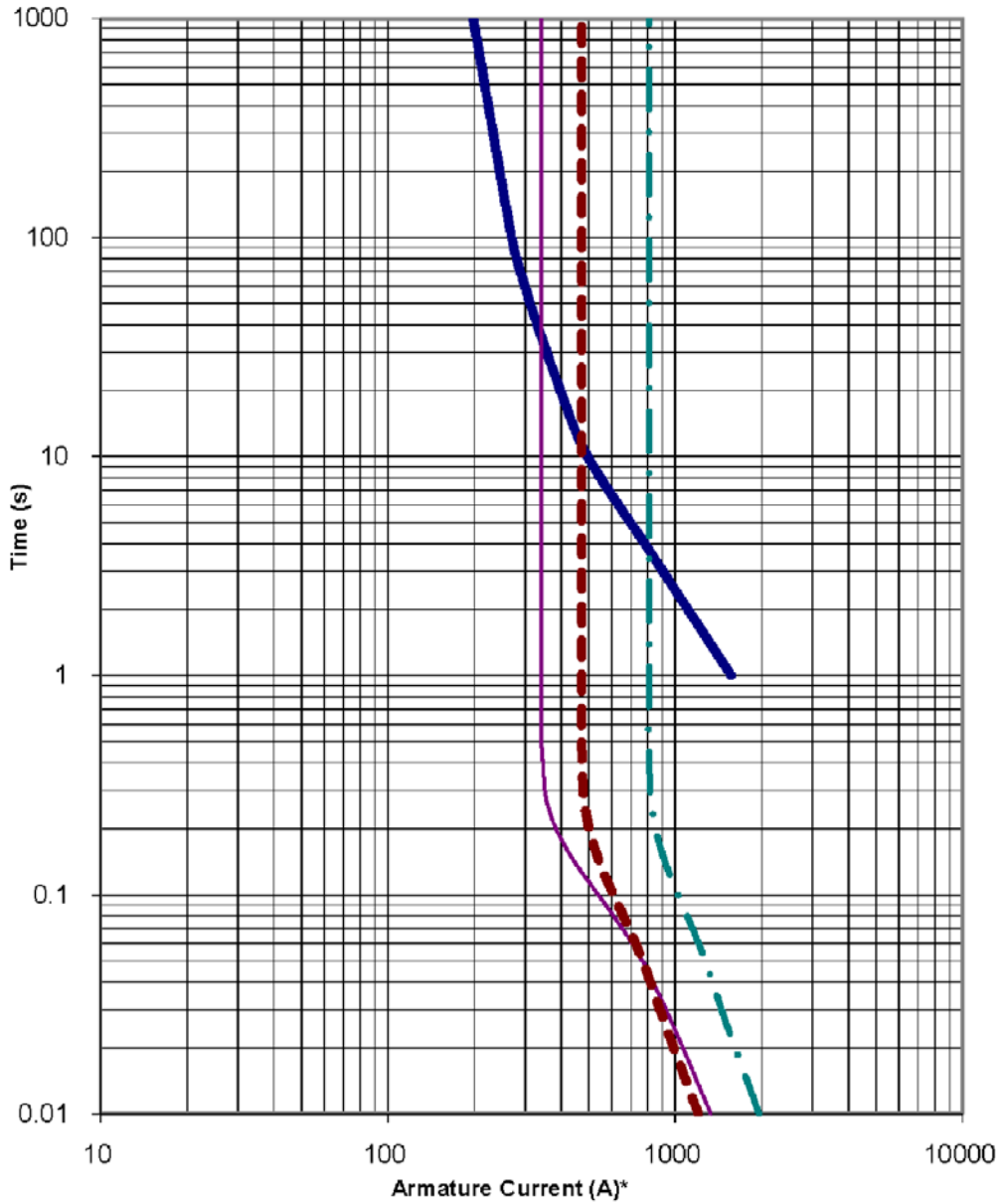

*Instantaneous current (t=0) is asymmetric. Divide by 1.73 for symmetric.

KOHLER®

Cooling Data

TECHNICAL INFORMATION BULLETIN

Generator Set Cooling System Data Sheet

KG100 60Hz (Standby Duty)	50°C Ambient Temperature Cooling System								
	Total external restriction on open unit ⁷	Pa (in.H ₂ O)	0 (0)	125 (0.5)	187 (0.75)	250 (1)	312 (1.25)	375 (1.5)	Enclosed Units
	Maximum allowable ambient temperature	°C (°F)	55 (131)	53 (127)	52 (126)	51 (124)	50 (122)	48 (118)	50 (122)
	Cooling system airflow	m ³ /min (ft ³ /min)	290 (10200)	273 (9600)	265 (9400)	257 (9100)	249 (8800)	241 (8500)	NA (NA)

1. The data shown above is the anticipated cooling performance for a typical generator set when following proper installation techniques.
2. Cooling performance is based on operation at 100 m (328 ft.) above sea level. For elevations higher than 100 m (328 ft.), typical cooling performance derate is 1°C (1.8°F) per 250 m (820 ft.).
3. For high ambient conditions, check TIB-101 for the generator set power output derate schedule.
4. Incorrect installation, improper operation, fouling of the cooling system, and other variable conditions may reduce cooling performance.
5. Kohler manufactured sound enclosed models are rated in free air with no additional restriction. Consult factory for other variants or conditions such as additional ducting or hoods.
6. Performance is based on a 50/50 water and ethylene glycol mixture.
7. Total external restriction includes restriction upstream and downstream of the unit – any ducting supplying intake air to the unit and any ducting for the discharge.

KOHLER®

Sound Data

TECHNICAL INFORMATION BULLETIN

Generator Set Sound Data Sheet

			Sound Pressure Data in dB(A)			
Generator Set Model	Hz	Load	Raw Exhaust	Open Unit, Isolated Exhaust	Weather Enclosure	Sound Enclosure
KG100	60	100% Load	98.9	83.2	81.3	69.3
		No Load	97.7	81.9	80.0	67.4

Note: Sound pressure data is the logarithmic average of eight perimeter measurement points at a distance of 7 m (23 ft.), except Raw Exhaust data which is a single measurement point at 1 m (3.3 ft.) from the mouth of a straight pipe exhaust.

KG100	60 Hz
-------	-------

				Sound Pressure Levels dB(A)								
Load	Distance, m (ft.)	Enclosure	Measurement Clock Position	Octave Band Center Frequency (Hz)								Overall Level
				63	125	250	500	1000	2000	4000	8000	
100% Load	7 (23)	Sound	3:00	46.3	60.4	60.7	62.1	60.7	58.5	53.4	48.0	67.8
			1:30	41.7	56.7	70.0	65.3	58.0	59.9	53.3	50.6	72.0
			12:00-Engine	47.4	61.3	65.1	61.4	61.6	59.5	55.4	51.2	69.5
			10:30	46.0	63.2	63.5	64.5	61.6	60.0	55.0	49.5	70.0
			9:00	46.3	61.5	60.7	63.0	59.7	59.3	52.9	50.1	68.3
			7:30	49.2	58.6	64.3	61.9	61.4	60.9	52.5	47.5	69.0
			6:00-Alternator	50.3	61.7	62.4	60.8	59.7	57.9	53.2	48.4	68.0
			4:30	47.4	58.8	62.0	61.8	60.8	60.1	53.5	48.0	68.1
			8-pos. log avg.	47.4	60.7	64.7	62.9	60.6	59.6	53.8	49.4	69.3

				Sound Pressure Levels dB(A)								
Load	Distance, m (ft.)	Enclosure	Measurement Clock Position	Octave Band Center Frequency (Hz)								Overall Level
				63	125	250	500	1000	2000	4000	8000	
No Load	7 (23)	Sound	3:00	42.6	53.5	59.5	59.7	56.7	54.8	48.4	41.3	64.7
			1:30	38.3	48.9	71.1	61.9	55.1	55.7	48.0	42.1	71.9
			12:00-Engine	42.3	54.5	64.3	58.5	59.4	56.8	50.9	48.5	67.2
			10:30	41.3	55.3	59.7	61.6	59.3	57.5	50.1	44.4	66.3
			9:00	42.4	54.2	63.1	59.7	56.6	55.9	48.1	43.1	66.2
			7:30	45.5	52.1	63.2	59.2	59.4	58.0	49.5	42.4	66.7
			6:00-Alternator	48.1	54.3	61.7	58.0	57.6	55.3	50.6	43.4	65.5
			4:30	46.9	51.8	60.5	60.4	57.7	57.2	49.3	42.7	65.6
			8-pos. log avg.	44.4	53.4	64.8	60.1	58.0	56.5	49.5	44.1	67.4

KOHLER®

Exhaust System Data

TECHNICAL INFORMATION BULLETIN

Enclosed Generator Set Exhaust System Data Sheet

Model	Enclosure Type	Consumed Back Pressure in. Hg (in. H ₂ O)	Consumed Back Pressure kPa	Back Pressure Limit(s) in. Hg (in. H ₂ O)	Back Pressure Limit(s) kPa	Flex Exhaust Tube(s)	Silencer	Drawing
KG100	All Weather and Sound Enclosures	2.6 (35.0)	8.8	4.4 (60.0)	14.9	GM104552 Flex Tube	GM104904 Catalyst Muffler OR GM114569 Catalyst Muffler	ADV-9080

1. Total system exhaust back pressure is applicable to generator sets equipped with Kohler standard enclosure packages.
2. For generator sets with multiple exhaust outlets, total system exhaust back pressure value represents each outlet.
3. The total system back pressure should not exceed the manufacturer's recommended limit.
4. The total back pressure only includes exhaust components installed inside the Kohler enclosure. Customers must calculate any additional back pressure caused by piping, extensions, or components added after the silencer outlet. Refer to the installation manual for additional details.

KOHLER®

Emissions Data



KG100

60 Hz. Gas Generator Set EPA Certified for Stationary Emergency Applications EMISSION DATA SHEET

ENGINE INFORMATION

Model:	KG6208THD	Bore:	101.6mm (4.00 in.)
Max kW @ 1800 RPM:	152 (NG) 131 (LPG)	Stroke:	95.25mm (3.75 in.)
Type:	4-Cycle, V8 Cylinder	Displacement:	6.2 L (378 cu. in.)
Aspiration:	Turbocharged	EPA Family:	RKHXB06.2HNL
Compression Ratio:	9.6:1	EPA Certificate:	RKHXB06.2HNL-005
Catalyst Required:	Yes		

EXHAUST EMISSION DATA¹ (g/kW-hr):

	<u>LPG</u>	<u>NG</u>
CO ₂	908	725
NOx	0.32	0.12
THC/VOC ²	0.04	0.00
CO	1.51	1.51
BSFC	304	244

1) Emissions shown are certified third-party zero-hour data points suitable for site permitting calculations

2) LPG as THC, NG as VOC

TEST METHODS AND CONDITIONS

Standby and overload ratings based on ISO 3046. Continuous ratings based on ISO 8528.

Max power rating is measured at the flywheel operating at standard conditions in a test cell.

Production tolerances in engines and installed components can account for power variations of +/- 5%. Corrections for altitude, temperature and excessive exhaust and intake restrictions should be applied to power calculations.

Electrical ratings are an estimate based on assumed fan and generator losses and may vary depending on actual equipment losses.

Emission rates are based on multi-mode, cycle-weighted testing in accordance with EPA regulations.

BSFC is based on cycle-weighted gross flywheel power rating and does not include fan or generator losses.

Data was taken from a single engine test according to EPA engine test methods, fuel specifications and reference conditions and is subject to instrumentation and engine-to-engine variability. Tests conducted with alternate test methods, instrumentation, fuel or reference conditions may yield different results.

Data and specifications subject to change without notice.

KOHLER®

Dimensional Drawings

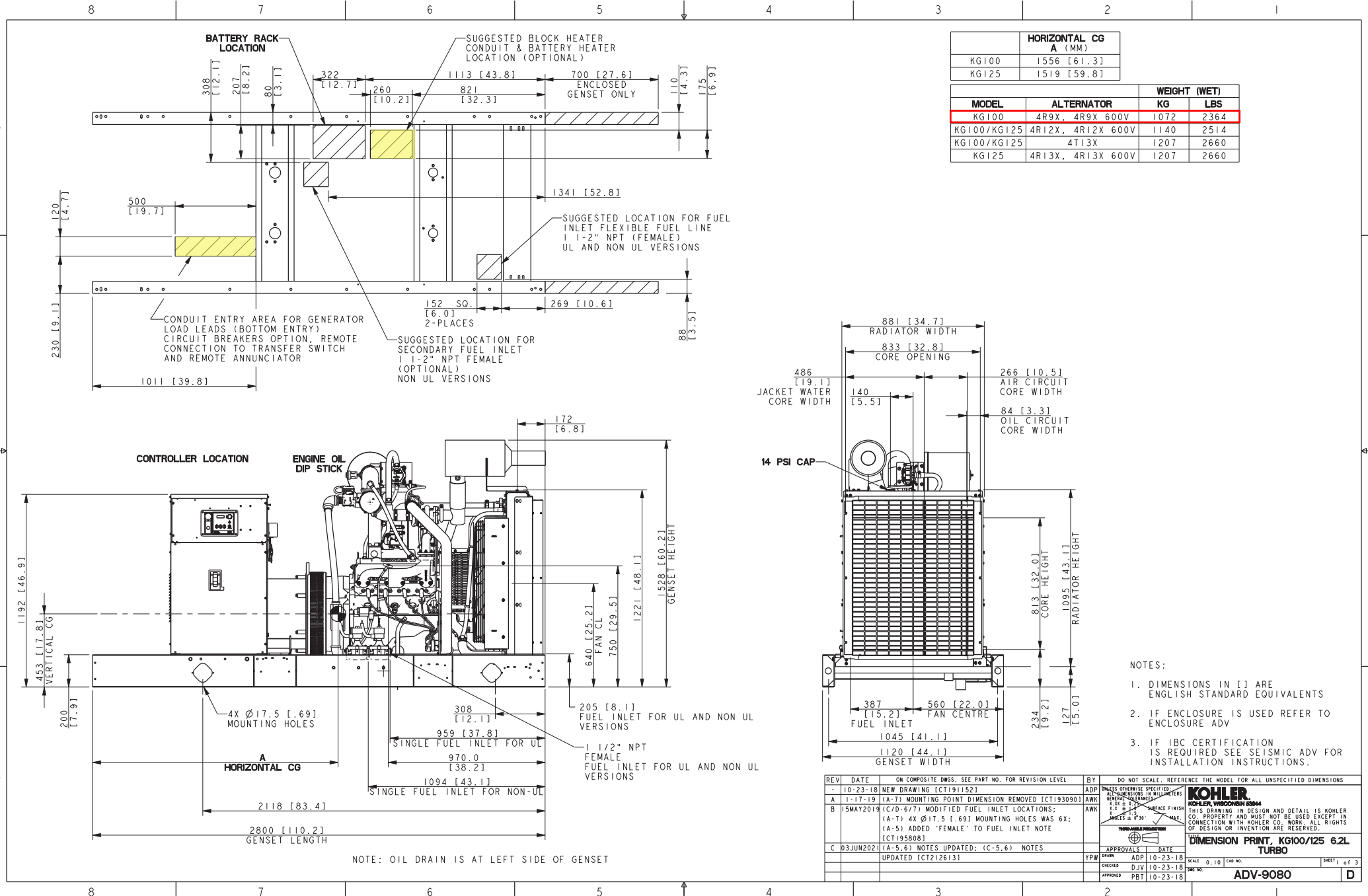

	HORIZONTAL CG A (MM)
KG100	1556 [61.3]
KG125	1519 [59.8]

MODEL	ALTERNATOR	WEIGHT (WET)	
		KG	LBS
KG100	4R9X, 4R9X 600V	1072	2364
KG100/KG125	4R12X, 4R12X 600V	1140	2514
KG100/KG125	4T13X	1207	2660
KG125	4R13X, 4R13X 600V	1207	2660

- NOTES:
1. DIMENSIONS IN [] ARE ENGLISH STANDARD EQUIVALENTS
 2. IF ENCLOSURE IS USED REFER TO ENCLOSURE ADV
 3. IF IBC CERTIFICATION IS REQUIRED SEE SEISMIC ADV FOR INSTALLATION INSTRUCTIONS.

REV	DATE	ON COMPOSITE DWGS, SEE PART NO. FOR REVISION LEVEL	BY	DO NOT SCALE, REFERENCE THE MODEL FOR ALL UNSPECIFIED DIMENSIONS
-	10-23-18	NEW DRAWING [CT191152]	ADP	UNLESS OTHERWISE SPECIFIED, DIMENSIONS IN MILLIMETERS
A	1-17-19	(A-7) MOUNTING POINT DIMENSION REMOVED [CT193090]	AWK	GENERAL TOLERANCES: 0.13 ± 0.13 SURFACE FINISH: 1.3 ± 0.13 ANGLES & P/30° MAX
B	15MAY2019	(C/D-6/7) MODIFIED FUEL INLET LOCATIONS: (A-7) 4X Ø17.5 [1.69] MOUNTING HOLES WAS 6X; (A-5) ADDED 'FEMALE' TO FUEL INLET NOTE [CT195808]	AWK	KOHLER KOHLER WISCONSIN 8384 THIS DRAWING IN DESIGN AND DETAIL IS KOHLER CO. PROPERTY AND MUST NOT BE USED EXCEPT IN CONNECTION WITH KOHLER CO. WORK. ALL RIGHTS OF DESIGN OR INVENTION ARE RESERVED.
C	03JUN2021	(A-5,6) NOTES UPDATED; (C-5,6) NOTES UPDATED [CT212613]	YPM	TURBO DIMENSION PRINT, KG100/125 6.2L TURBO SCALE 0.10 CAD NO. ADV-9080 SHEET 1 of 3

NOTE: OIL DRAIN IS AT LEFT SIDE OF GENSET

8 7 6 5 4 3 2 1

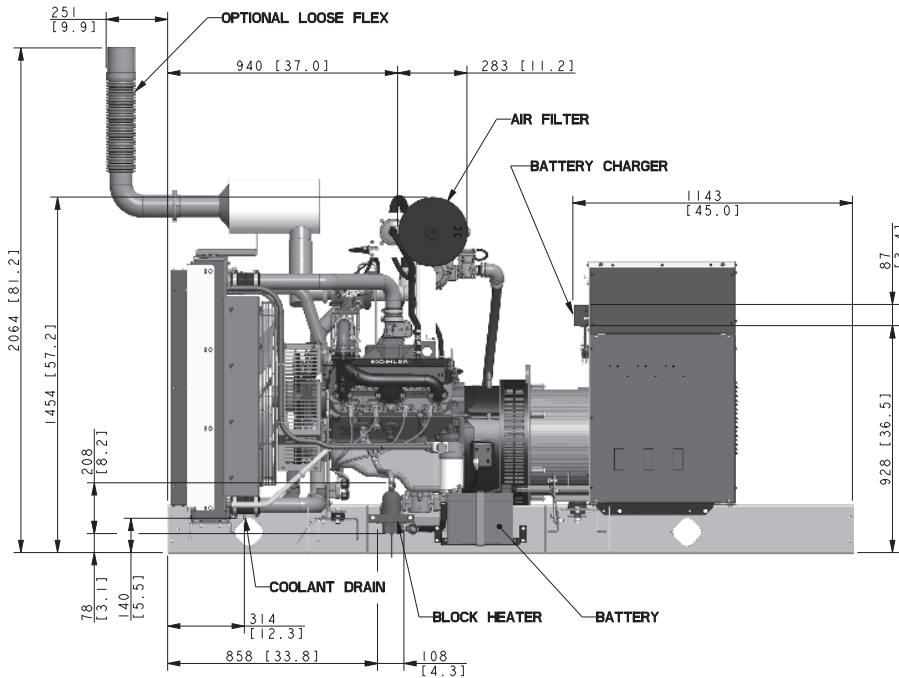
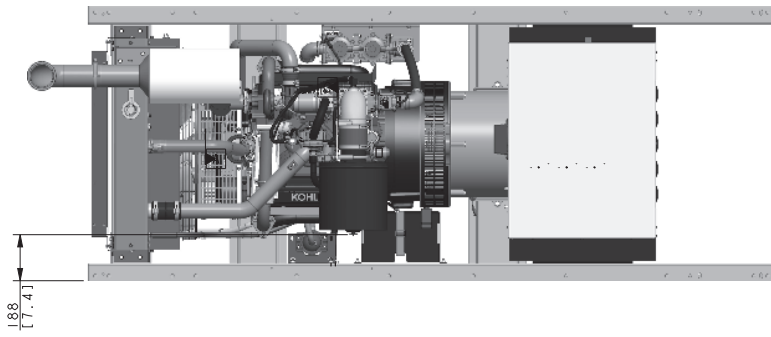

**BLOCK HEATER, AIR FILTER & BATTERY CHARGER
(LEFT SIDE OF GENSET)**

NOTE:
LEFT SIDE SKID MEMBER HIDDEN TO SHOW BLOCK HEATER

8 7 6 5 4 3 2 1

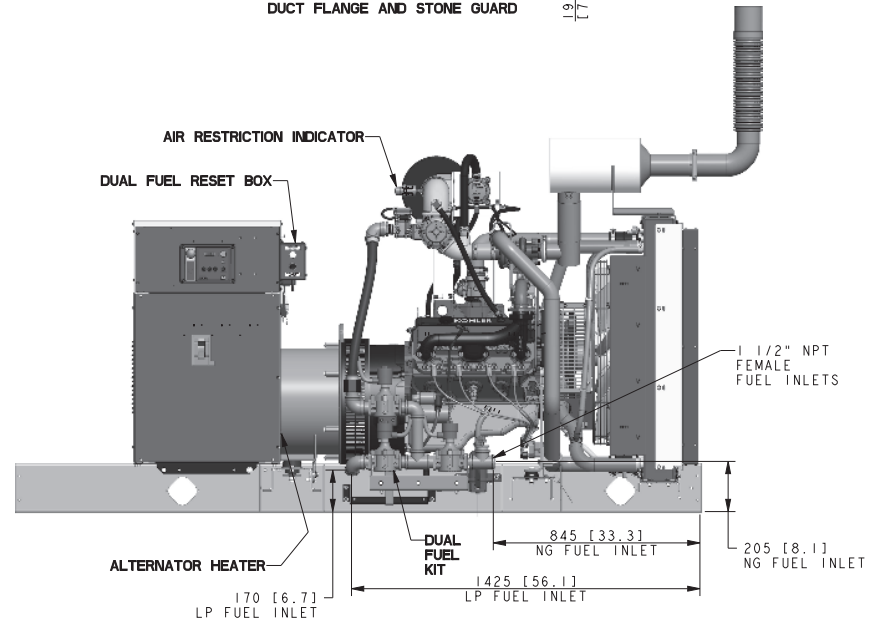
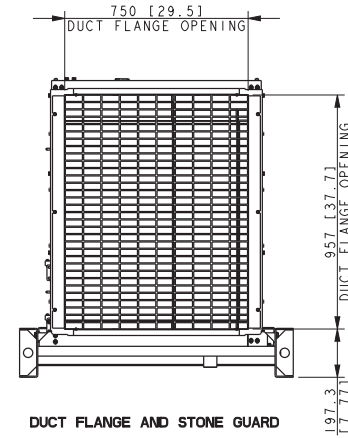

**DUAL FUEL, RESET BOX & AIR RESTRICTION INDICATOR
(RIGHT SIDE OF GENSET)**

NOTE:
RIGHT SIDE SKID MEMBER HIDDEN TO SHOW DUAL FUEL KIT

REV	DATE	ON COMPOSITE DWGS. SEE PART NO. FOR REVISION LEVEL	BY	DO NOT SCALE. REFERENCE THE MODEL FOR ALL UNSPECIFIED DIMENSIONS										
-	10-23-18	NEW DRAWING [CT191152]	ADP	<small>UNLESS OTHERWISE SPECIFIED: DIMENSIONS ARE IN MILLIMETERS GENERAL TOLERANCES FRACTIONS DECIMALS ANGLES & SURFACE FINISH UNLESS OTHERWISE SPECIFIED</small>										
A	2-7-19	SEE SHEET 1 [CT193090]	AWK											
B	15MAY2019	FLEX EXHAUST KIT ADDED TO SHADED VIEWS [CT195808]	AWK											
C	03JUN2021	SEE SHEET 1 [CT212613]	YPR											
<table border="0"> <tr> <td>APPROVALS</td> <td>DATE</td> <td rowspan="4"> </td> <td rowspan="4"> KOHLER <small>KOHLER WISCONSIN 83844</small> THIS DRAWING IN DESIGN AND DETAIL IS KOHLER CO. PROPERTY AND MUST NOT BE USED EXCEPT IN CONNECTION WITH KOHLER CO. WORK. ALL RIGHTS OF DESIGN OR INVENTION ARE RESERVED. </td> </tr> <tr> <td>DRW</td> <td>ADP 10-23-18</td> </tr> <tr> <td>CHECKED</td> <td>DJV 10-23-18</td> </tr> <tr> <td>APPROVED</td> <td>PBT 10-23-18</td> </tr> </table>					APPROVALS	DATE		KOHLER <small>KOHLER WISCONSIN 83844</small> THIS DRAWING IN DESIGN AND DETAIL IS KOHLER CO. PROPERTY AND MUST NOT BE USED EXCEPT IN CONNECTION WITH KOHLER CO. WORK. ALL RIGHTS OF DESIGN OR INVENTION ARE RESERVED.	DRW	ADP 10-23-18	CHECKED	DJV 10-23-18	APPROVED	PBT 10-23-18
APPROVALS	DATE		KOHLER <small>KOHLER WISCONSIN 83844</small> THIS DRAWING IN DESIGN AND DETAIL IS KOHLER CO. PROPERTY AND MUST NOT BE USED EXCEPT IN CONNECTION WITH KOHLER CO. WORK. ALL RIGHTS OF DESIGN OR INVENTION ARE RESERVED.											
DRW	ADP 10-23-18													
CHECKED	DJV 10-23-18													
APPROVED	PBT 10-23-18													
DIMENSION PRINT, KG100/125 6.2L TURBO			SCALE 0.10 CAD NO. _____ SHEET 3 of 3 DWG NO. ADV-9080											

DIM (MM)	80	100	100/125
A (COB)	1615	1651	1598
B (HEIGHT)	1709	1713	1713

MODEL	ALTERNATOR	GENSET WGT (WET) W/ ENCL			ENCLOSURE ONLY	
		KG	LBS	KG	LBS	
KG80	4R9X/4T9X	STEEL WEATHER	1417	3123	391	863
		STEEL SOUND	1427	3146	402	886
	4P10X	ALUM SOUND	1337	2948	312	688
		STEEL WEATHER	1394	3073	391	863
KG100	4R9X	STEEL SOUND	1404	3096	402	886
		ALUM SOUND	1315	2898	312	688
	4R12X	STEEL WEATHER	1471	3243	399	879
		STEEL SOUND	1492	3290	409	902
KG100/125	4R12X	ALUM SOUND	1381	3044	319	704
		STEEL WEATHER	1539	3393	399	879
	4R13X/4T13X	STEEL SOUND	1549	3416	409	902
		ALUM SOUND	1460	3218	319	704
		STEEL WEATHER	1605	3539	399	879
		STEEL SOUND	1616	3562	409	902
		ALUM SOUND	1515	3340	319	704

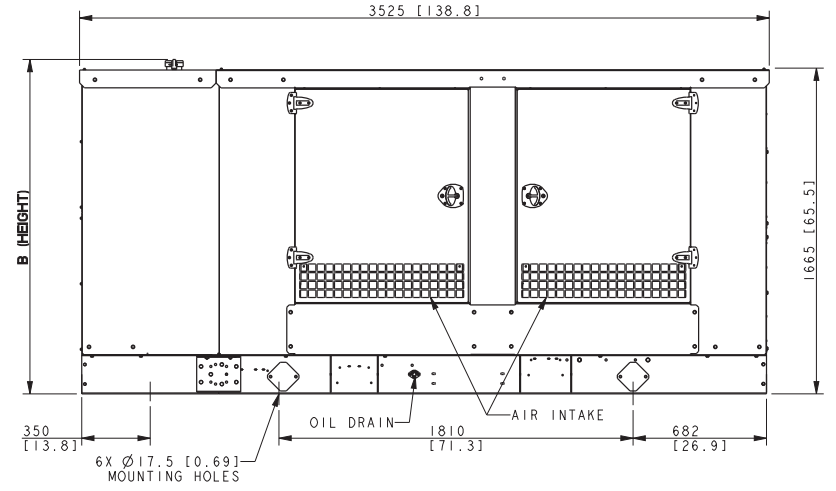
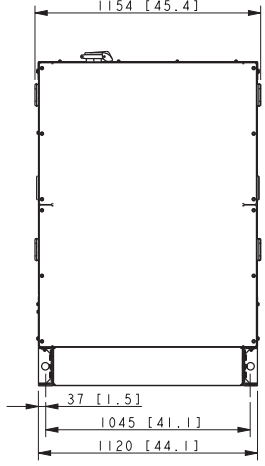
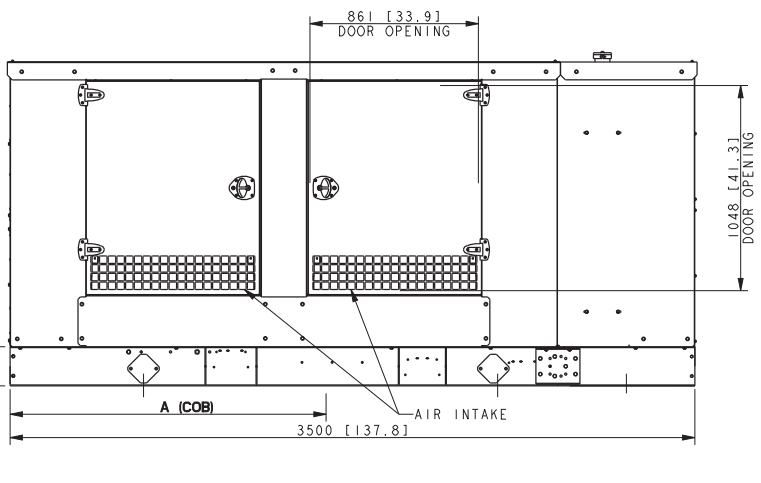
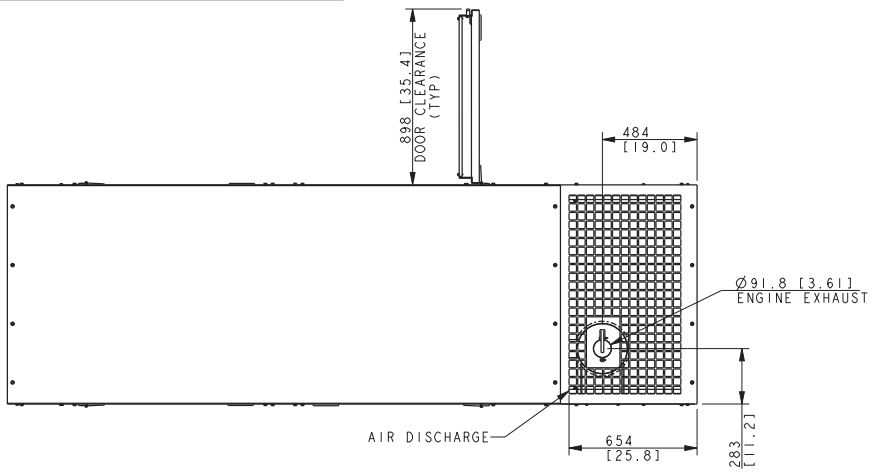

DIMENSIONS IN [] ARE IN ENGLISH EQUIVALENTS.

REV	DATE	ON COMPOSITE DWGS. SEE PART NO. FOR REVISION LEVEL	BY	DO NOT SCALE. REFERENCE THE MODEL FOR ALL UNSPECIFIED DIMENSIONS
-	10-23-18	NEW DRAWING [CT191152]	ADP	UNLESS OTHERWISE SPECIFIED, DIMENSIONS IN MILLIMETERS SHALL BE TO NEAREST 0.13 mm (0.005 in). DIMENSIONS IN INCHES SHALL BE TO NEAREST 0.001 in. UNLESS OTHERWISE SPECIFIED, DIMENSIONS SHALL BE TO NEAREST 0.001 in. UNLESS OTHERWISE SPECIFIED, DIMENSIONS SHALL BE TO NEAREST 0.001 in. UNLESS OTHERWISE SPECIFIED, DIMENSIONS SHALL BE TO NEAREST 0.001 in.
A	1-16-19	(A-4) NOTE REMOVED; (A-1) MOUNTING POINT DIMENSION REMOVED [CT193090]	AWK	
B	14MAY2019	(B-4) 'B' WAS 'D'; (D-8) 'B' ADDED TO TABLE; (A-4) 6X Ø17.5 [0.69] WAS 8X [CT195808]	AWK	

KOHLER
 KOHLER WISCONSIN 8384
 THIS DRAWING IN DESIGN AND DETAIL IS KOHLER CO. PROPERTY AND MUST NOT BE USED EXCEPT IN CONNECTION WITH KOHLER CO. WORK. ALL RIGHTS OF DESIGN OR INVENTION ARE RESERVED.

ADV-9083

APPROVALS: _____ DATE: _____
 DRAWN: ADP 10-23-18
 CHECKED: DJV 10-23-18
 APPROVED: PBT 10-23-18

SCALE: 0.08 [1/4" = 1'-0"] SHEET 1 of 1

PART NO.	REV	ITEM 1	ITEM 2	ITEM 3	COMMENTS
GM85123-1	C	GM85127	GM85129	GM86126-1	MULTIPLE ATS
GM85123-2	C	GM85131	GM85129	GM86126-2	SINGLE ATS
GM85123-3	C	GM85132	-	GM86126-3	ANNUNCIATOR ONLY
GM85123-4	C	GM85133	-	GM86126-3	SDMO - ANNUNCIATOR ONLY

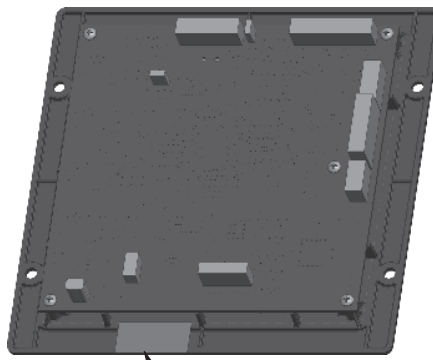
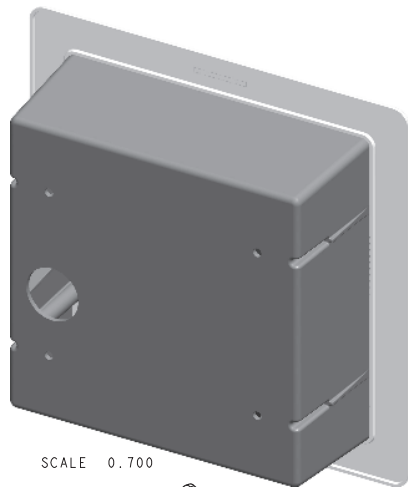

- NOTES:
- FUNCTIONALLY TEST ACCORDING TO ISO DOCUMENT ETF-WI-001, PER SPECIFICATION ETF-TD-003.
 - ASSEMBLE PCBA TO BACK OF BEZEL USING FIXTURE JT-0001.
 - TORQUE ALL SCREWS TO 7-10 in lbs.
 - PEEL BACKING OFF FACE PLATE AND APPLY TO BEZEL. APPLY EVEN PRESSURE TO ENTIRE SURFACE TO ENSURE COMPLETE ADHESION.

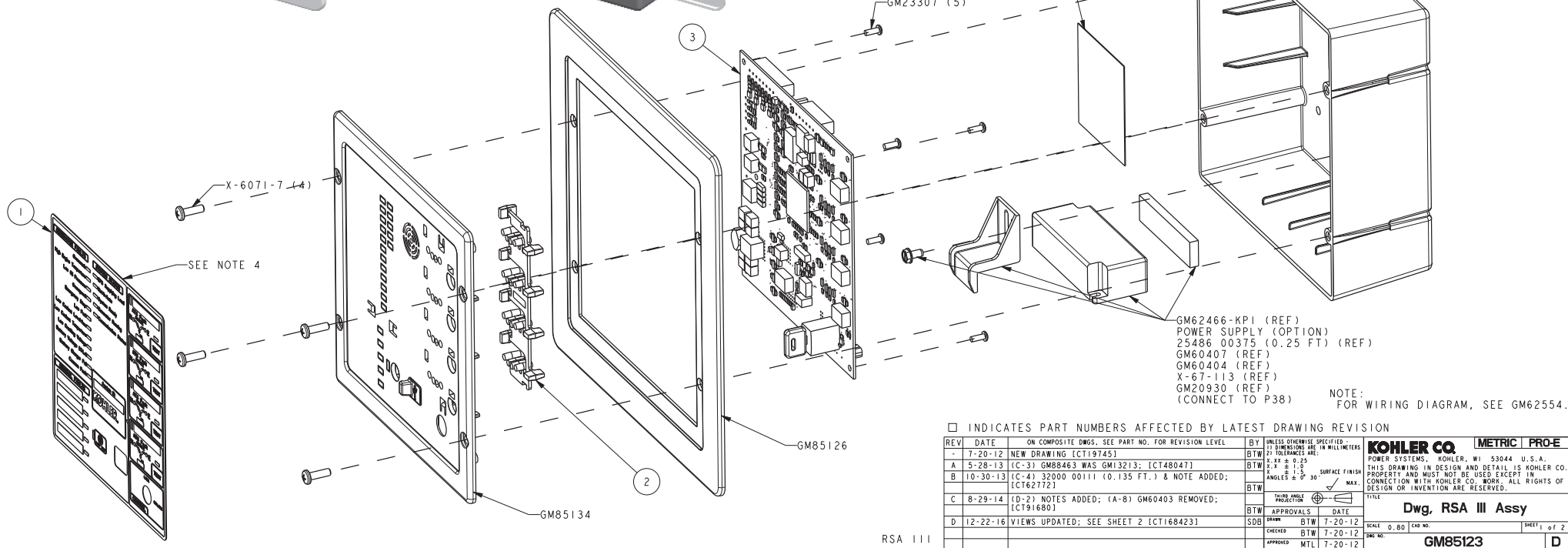

□ INDICATES PART NUMBERS AFFECTED BY LATEST DRAWING REVISION

REV	DATE	ON COMPOSITE DWGS. SEE PART NO. FOR REVISION LEVEL	BY	UNLESS OTHERWISE SPECIFIED: 2) DIMENSIONS ARE IN MILLIMETERS
-	7-20-12	NEW DRAWING [CT19745]	BTW	2) TOLERANCES ARE: X .XX ± 0.25 Y .X ± 0.15 Z .X ± 0.15 SURFACE FINISH ANGLES ± 0° 30' / MAX.
A	5-28-13	(C-3) GM88463 WAS GM13213; [CT48047]	BTW	
B	10-30-13	(C-4) 32000 00111 (0.135 FT.) & NOTE ADDED; [CT62772]	BTW	
C	8-29-14	(D-2) NOTES ADDED; (A-8) GM60403 REMOVED; [CT191680]	BTW	
D	12-22-16	VIEWS UPDATED; SEE SHEET 2 [CT1684231]	BTW	

BTW	APPROVALS	DATE
SDH	BTW	7-20-12
BTW	BTW	7-20-12
MTL	BTW	7-20-12

KOHLER CO. METRIC PRO-E	
POWER SYSTEMS, KOHLER, WI 53044 U.S.A.	
THIS DRAWING IN DESIGN AND DETAIL IS KOHLER CO. PROPERTY AND MUST NOT BE USED EXCEPT IN CONNECTION WITH KOHLER CO. WORK. ALL RIGHTS OF DESIGN OR INVENTION ARE RESERVED.	
TITLE	Dwg, RSA III Assy
SCALE	0.80 CAD NO.
DWG NO.	GM85123
SHEET	1 of 2

RSA III

8 7 6 5 4 3 2 1

SNAP ITEM 2 INTO THIS LOCATION BEING SURE TO LINE-UP ALL LIGHT PIPES TO MATCHING SOCKETS ON BEZEL.

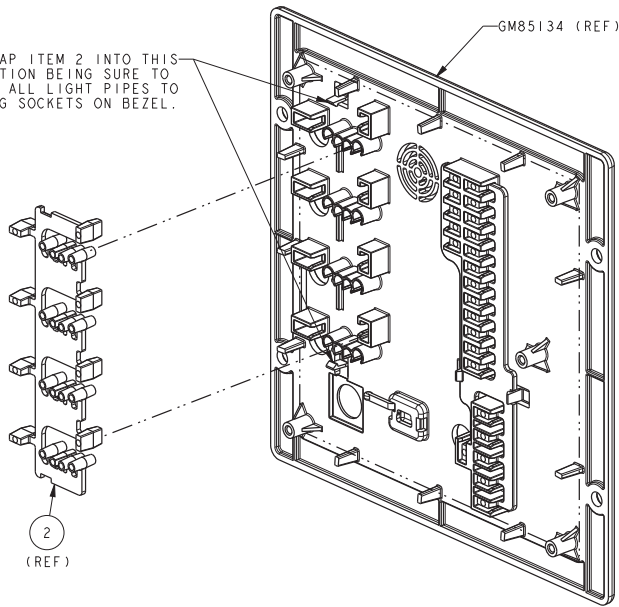

BACK VIEW OF BEZEL
SCALE 1.000

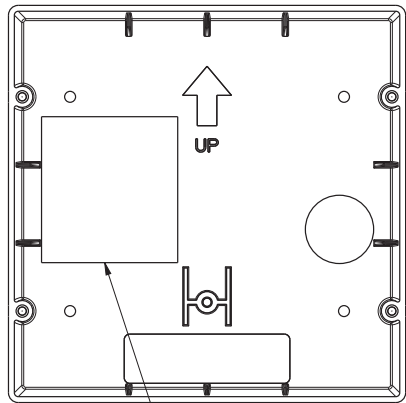

VIEW B
FRONT OF BOX

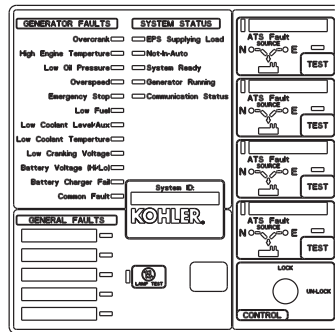

ITEM 1
(P/N: GM85127 REF)

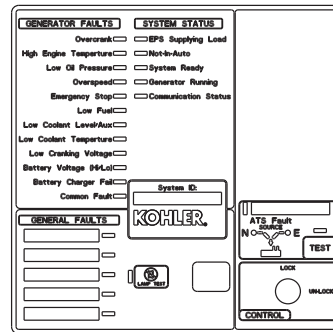

ITEM 1
(P/N: GM85131 REF)

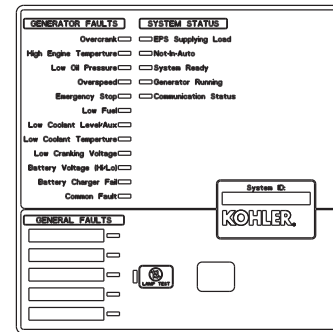

ITEM 1
(P/N: GM85132 REF)

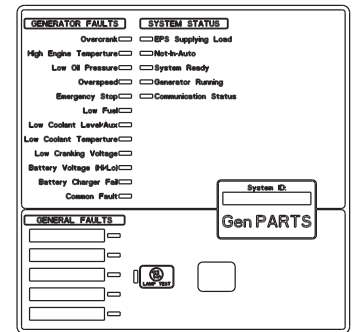

ITEM 1
(P/N: GM85133 REF)

REV	DATE	ON COMPOSITE DWGS. SEE PART NO. FOR REVISION LEVEL	BY	UNLESS OTHERWISE SPECIFIED: 2) DIMENSIONS ARE IN MILLIMETERS	KOHLER CO. METRIC PRO-E POWER SYSTEMS, KOHLER, WI 53044 U.S.A. THIS DRAWING IN DESIGN AND DETAIL IS KOHLER CO. PROPERTY AND MUST NOT BE USED EXCEPT IN CONNECTION WITH KOHLER CO. WORK. ALL RIGHTS OF DESIGN OR INVENTION ARE RESERVED.
-	7-30-12	NEW DRAWING [CT19745]	BTW	Z, XX ± 0.25	
A	5-28-13	(A-8) GM88463 (REF) WAS GM13213 (REF); [CT48047]	BTW	Z, Y ± 1.5 SURFACE FINISH	
B	10-30-13	SEE SHEET 1 [CT62772]	BTW	ANGLES ± 0° 30' / MAX.	
C	8-29-14	VIEW A REMOVED; [CT91680]	BTW	VIEW ANGLE PROJECTION	
D	12-22-16	VIEWS UPDATED; SEE SHEET 1 [CT168423]	SDR	APPROVALS DATE	
			DRW	BTW 7-30-12	
			CHECKED	BTW 7-30-12	
			APPROVED	MTL 7-30-12	

Dwg. RSA III Assy
SCALE 0.80 CAD NO. SHEET 2 of 2
GM85123 D

8 7 6 5 4 3 2 1

KOHLER®

Wiring Schematics

Nc.	Part Numbers	Description	Options	Field
1	GV101027	Harness, Engine, 6.2L Inc. Turbo <G100/125	-	-
2	GV101025	Harness, Control, 6.2L Inc. Turbo, KG80/100/125	-	-
3	GVXXXXX	48/60RCL3 Voltage hookup cables	-	-
4	GVXXXXX	Battery Cables	-	-
5	N/A	Utility wiring	-	X
6	N/A	Site network cables	-	X
7	N/A	Site emergency service wiring	-	X
8	-	-	-	-
9	-	-	-	-
10	-	-	-	-

REV	DATE	REVISION	BY
4	05-19	NEW DRAWING [C1186971]	TEV
A	1-29-19	UPDATES FROM PRE-PRO BUILD [C1193360]	TEV
B	5-6-19	SEE SHEETS 3 & 4 [C1195555]	SMH
C	04-16-20	SEE SHEET 3 [C1203384]	SMH

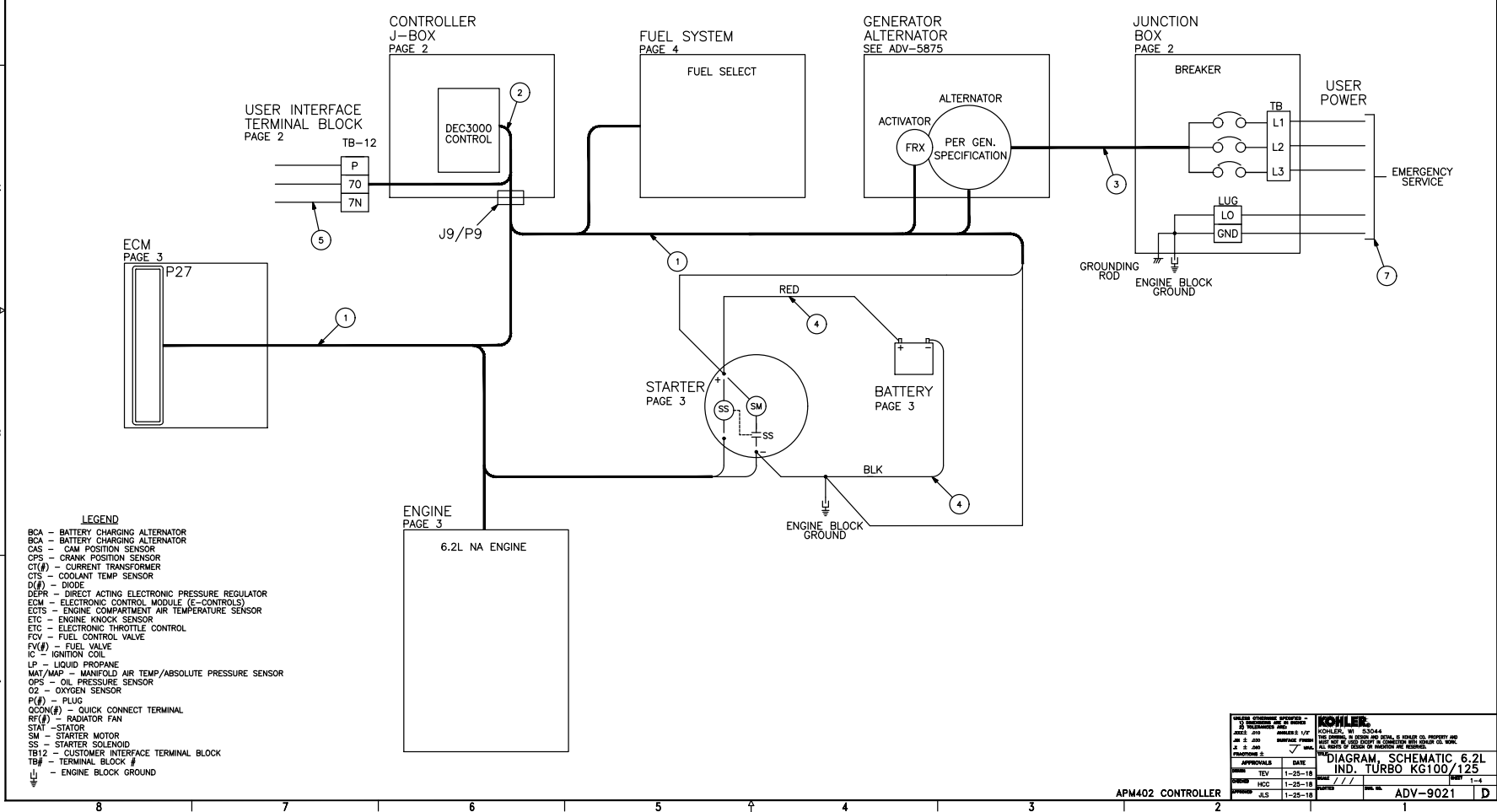

LEGEND

- BCA - BATTERY CHARGING ALTERNATOR
- BCA - BATTERY CHARGING ALTERNATOR
- CAS - CAM POSITION SENSOR
- CPS - CRANK POSITION SENSOR
- CT(4) - CURRENT TRANSFORMER
- CTS - COOLANT TEMP SENSOR
- D(4) - DIODE
- DEPR - DIRECT ACTING ELECTRONIC PRESSURE REGULATOR
- ECM - ELECTRONIC CONTROL MODULE (E-CONTROLS)
- ECTS - ENGINE COMPARTMENT AIR TEMPERATURE SENSOR
- ETS - ENGINE KNOCK SENSOR
- ETC - ELECTRONIC THROTTLE CONTROL
- FCV - FUEL CONTROL VALVE
- FV(4) - FUEL VALVE
- IC - IGNITION COIL
- LP - LIQUID PROPANE
- MAT/MAP - MANIFOLD AIR TEMP/ABSOLUTE PRESSURE SENSOR
- OPS - OIL PRESSURE SENSOR
- O2 - OXYGEN SENSOR
- P(4) - PULS
- QCON(4) - QUICK CONNECT TERMINAL
- RF(4) - RADIATOR FAN
- STAT - STATOR
- SM - STARTER MOTOR
- SS - STARTER SOLENOID
- TE12 - CUSTOMER INTERFACE TERMINAL BLOCK
- TB# - TERMINAL BLOCK #
- ⏚ - ENGINE BLOCK GROUND

APPROVALS	DATE	REVISION
TEV	1-25-18	1
SMH	1-25-18	2
SMH	1-25-18	3

DIAGRAM, SCHEMATIC 6.2L IND. TURBO KG100/125
 ADV-9021

APM402 CONTROLLER

REV	DATE	REVISION	BY
-	4-25-18	NEW DRAWING [CT186971]	TEV
A	1-29-19	UPDATES FROM PRE-PRO BUILD [CT193360]	TEV
B	5-6-19	SEE SHEETS 3 & 4 [CT195555]	SMH
C	04-16-20	SEE SHEET 3 [CT203364]	SRM

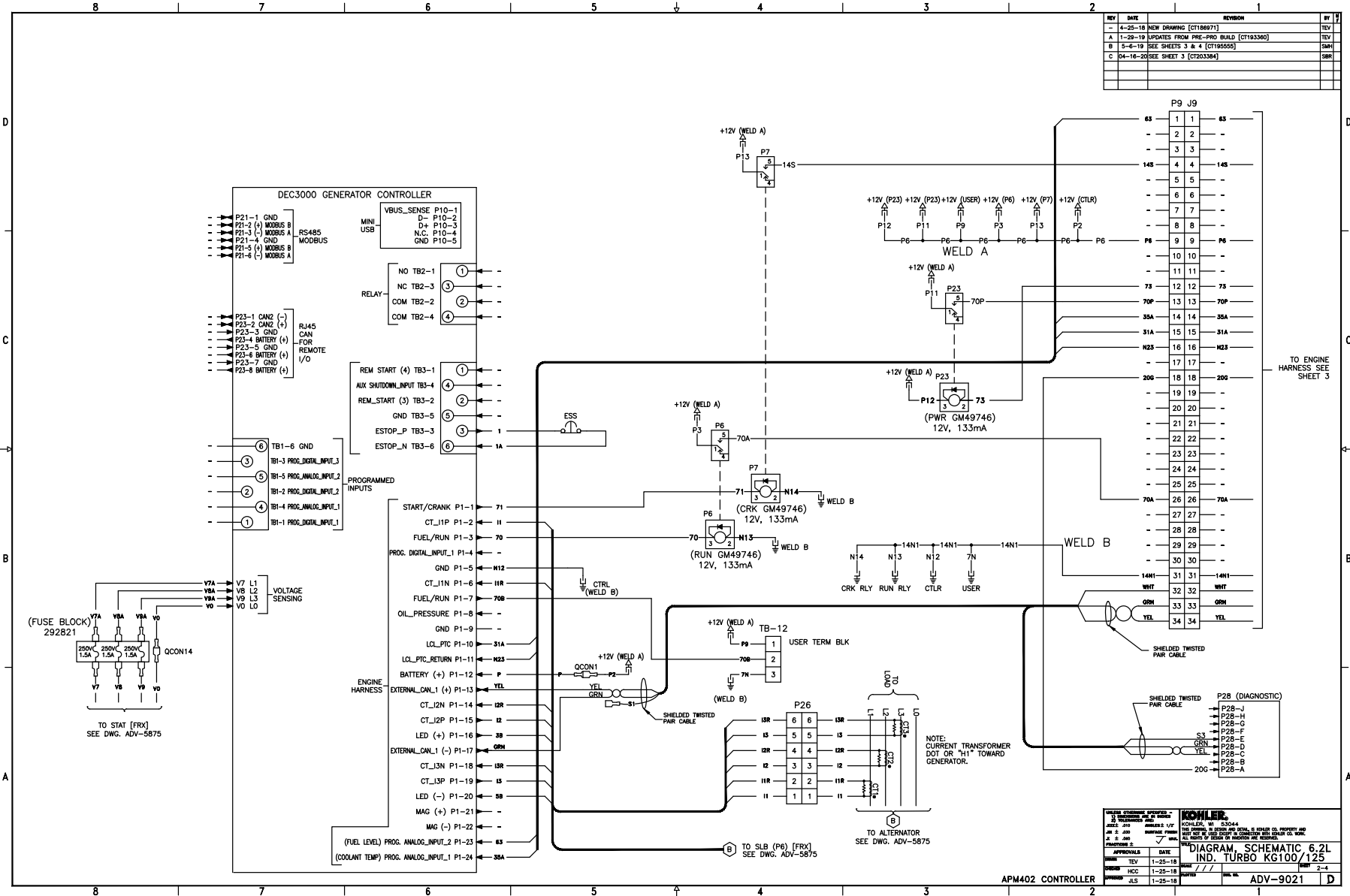

APPROVALS	DATE	REVISION
TEV	1-25-18	1
SMH	1-25-18	2
SRM	1-25-18	3

KOHLER
IND. TURBO KG100/125
ADV-9021

REV	DATE	REVISION	BY
4-25-18		NEW DRAWING [CT186971]	TEV
A 1-29-19		UPDATES FROM PRE-PRO BUILD [CT193360]	TEV
B 5-6-19		(C-4) P32 (O2) POST CAT IS REMOVED; SEE SHEET 4	SMH
[CT195055]			
C 04-16-20		(C-3, -4) UPDATED P22 (O2) CONNECTIONS; (C-2) ADDED P20 (CTS)	SMH

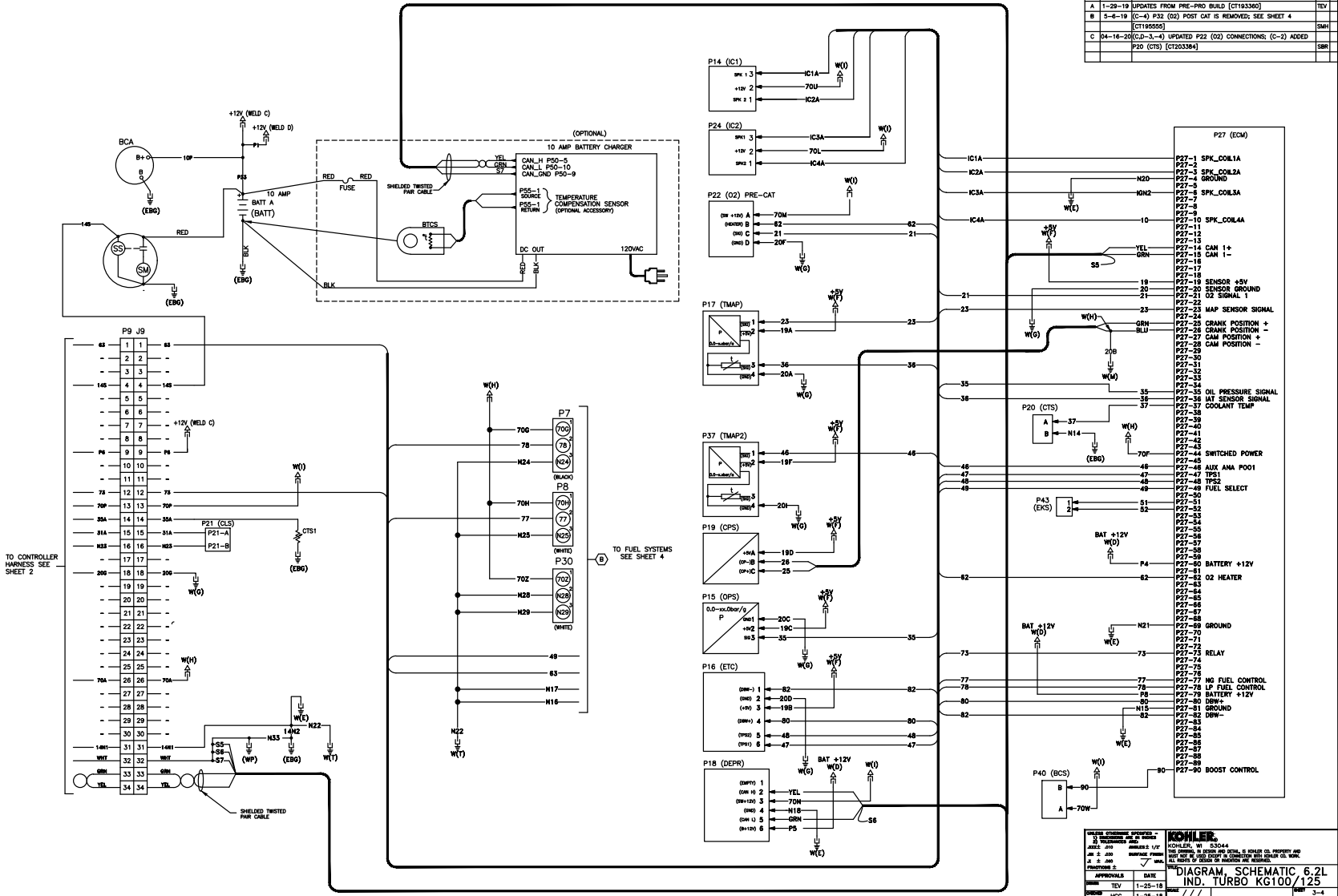

APPROVALS	DATE	REVISION	BY
TEV	1-25-18		
SMH	1-25-18		
SMH	1-25-18		

KOHLER
 KOHLER, WI 53044
 125 WEST WISCONSIN AVENUE, SUITE 100, WAUKESHA, WI 53090
 ALL RIGHTS RESERVED. NO PARTS OR SERVICES TO BE SHIPPED OR SOLD WITHOUT WRITTEN PERMISSION FROM KOHLER.

DIAGRAM, SCHEMATIC 6.2L IND. TURBO KG100/125

ADV-9021

APM402 CONTROLLER

REV	DATE	REVISION	BY
4	12-18	NEW DRAWING [C7186971]	TEV
A	1-29-19	UPDATES FROM PRE-PRO BUILD [C7193360]	TEV
B	5-8-19	(BLC-2-3-4) AUTO CHANGEOVER LAYOUT IS UPDATED, SEE SHEET 3 [C7195555]	SMH
C	04-16-20	SEE SHEET 3 [C7203384]	SMH

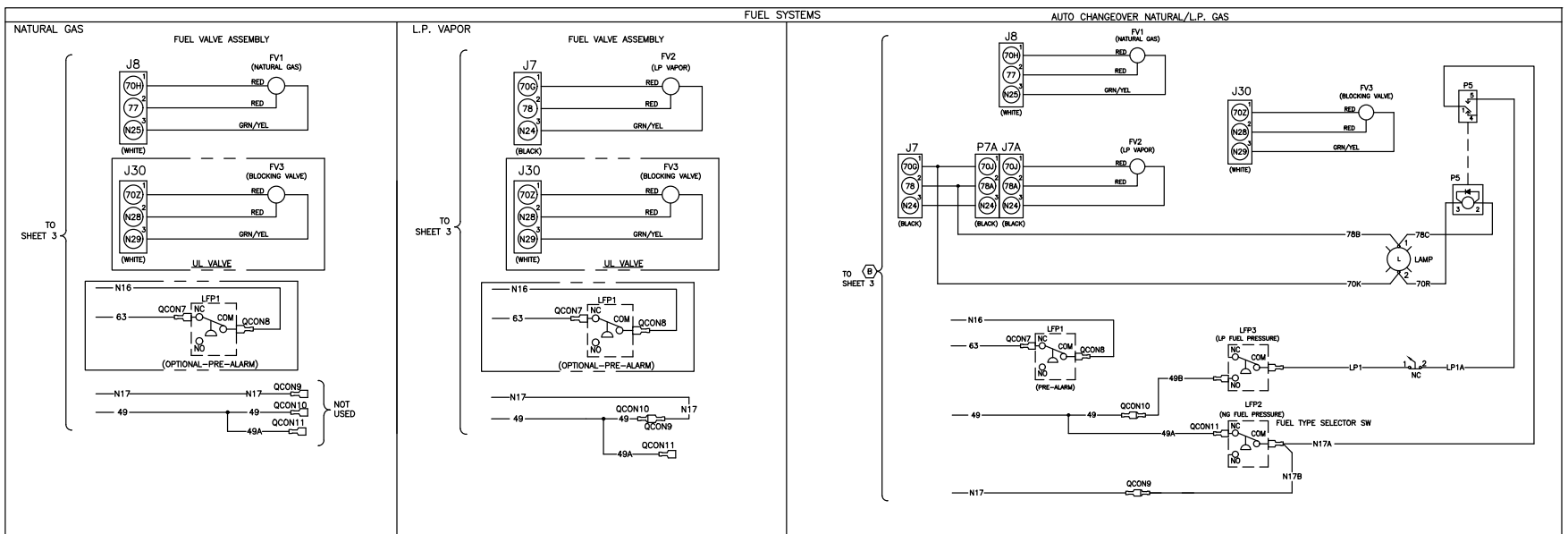

APPROVALS	DATE
TEV	1-25-18
SMH	1-25-18
CLS	1-25-18

KOHLER
 6.2L
 IND. TURBO KG100/125

ADV-9021

APM402 CONTROLLER

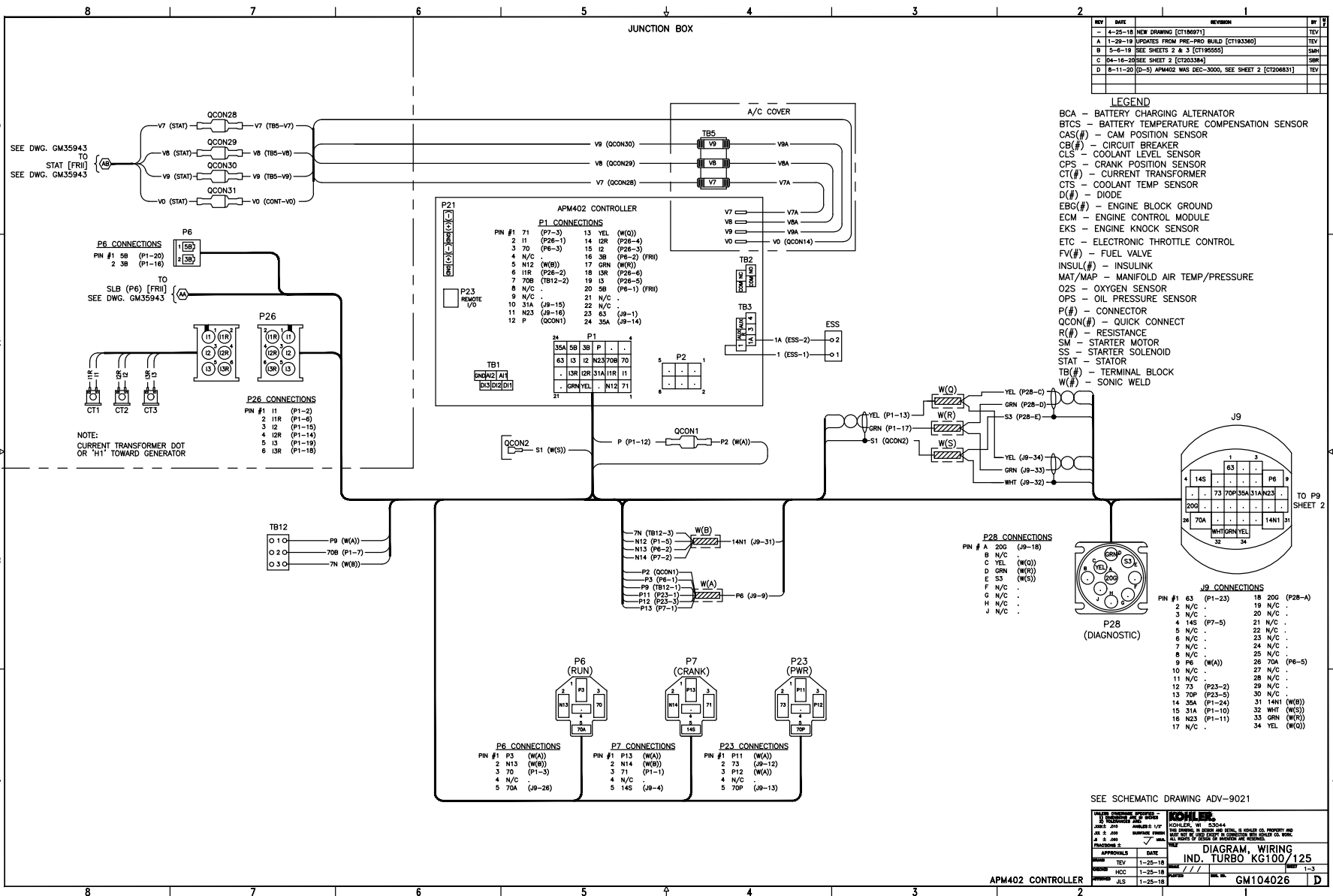

REV	DATE	REVISION	BY
-	4-25-18	NEW DRAWING [CT186971]	TEV
A	1-29-19	UPDATES FROM PRE-PRO BUILD [CT186380]	TEV
B	5-8-19	SEE SHEETS 2 & 3 [CT18655]	SMH
C	04-16-20	SEE SHEET 2 [CT203384]	SMH
D	8-11-20	APM402 WAS DEC-3000, SEE SHEET 2 [CT206831]	TEV

- LEGEND**
- BCA - BATTERY CHARGING ALTERNATOR
 - BTCS - BATTERY TEMPERATURE COMPENSATION SENSOR
 - CAS(#)- CAM POSITION SENSOR
 - CB(#)- CIRCUIT BREAKER
 - CLS - COOLANT LEVEL SENSOR
 - CPS - CRANK POSITION SENSOR
 - CT(#)- CURRENT TRANSFORMER
 - CTS - COOLANT TEMP SENSOR
 - D(#)- DIODE
 - EBG(#)- ENGINE BLOCK GROUND
 - ECM - ENGINE CONTROL MODULE
 - EKS - ENGINE KNOCK SENSOR
 - ETC - ELECTRONIC THROTTLE CONTROL
 - FV(#)- FUEL VALVE
 - INSUL(#)- INSULINK
 - MAT/MAP - MANIFOLD AIR TEMP/PRESSURE
 - O2S - OXYGEN SENSOR
 - OPS - OIL PRESSURE SENSOR
 - P(#)- CONNECTOR
 - QCON(#)- QUICK CONNECT
 - R(#)- RESISTANCE
 - SM - STARTER MOTOR
 - SS - STARTER SOLENOID
 - STAT - STATOR
 - TB(#)- TERMINAL BLOCK
 - W(#)- SONIC WELD

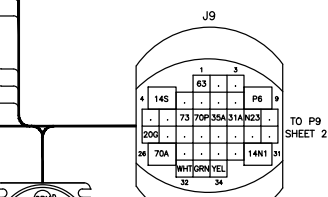

J9 CONNECTIONS

PIN #	WIRE	CONNECTION
1	N/C	18 20G (P28-A)
2	N/C	19 N/C
3	N/C	20 N/C
4	14S (P7-5)	21 N/C
5	N/C	22 N/C
6	N/C	23 N/C
7	N/C	24 N/C
8	N/C	25 N/C
9	P6 (W(A))	26 70A (P6-5)
10	N/C	27 N/C
11	N/C	28 N/C
12	7S (P23-2)	29 N/C
13	70P (P23-5)	30 N/C
14	35A (P1-24)	31 14N1 (W(B))
15	31A (P1-10)	32 WHT (W(S))
16	N23 (P1-11)	33 GRN (W(R))
17	N/C	34 YEL (W(O))

SEE SCHEMATIC DRAWING ADV-9021

APPROVALS	DATE
TEV	1-25-18
HCC	1-25-18
ALS	1-25-18

IND. TURBO KG100/125

APM402 CONTROLLER

GM104026

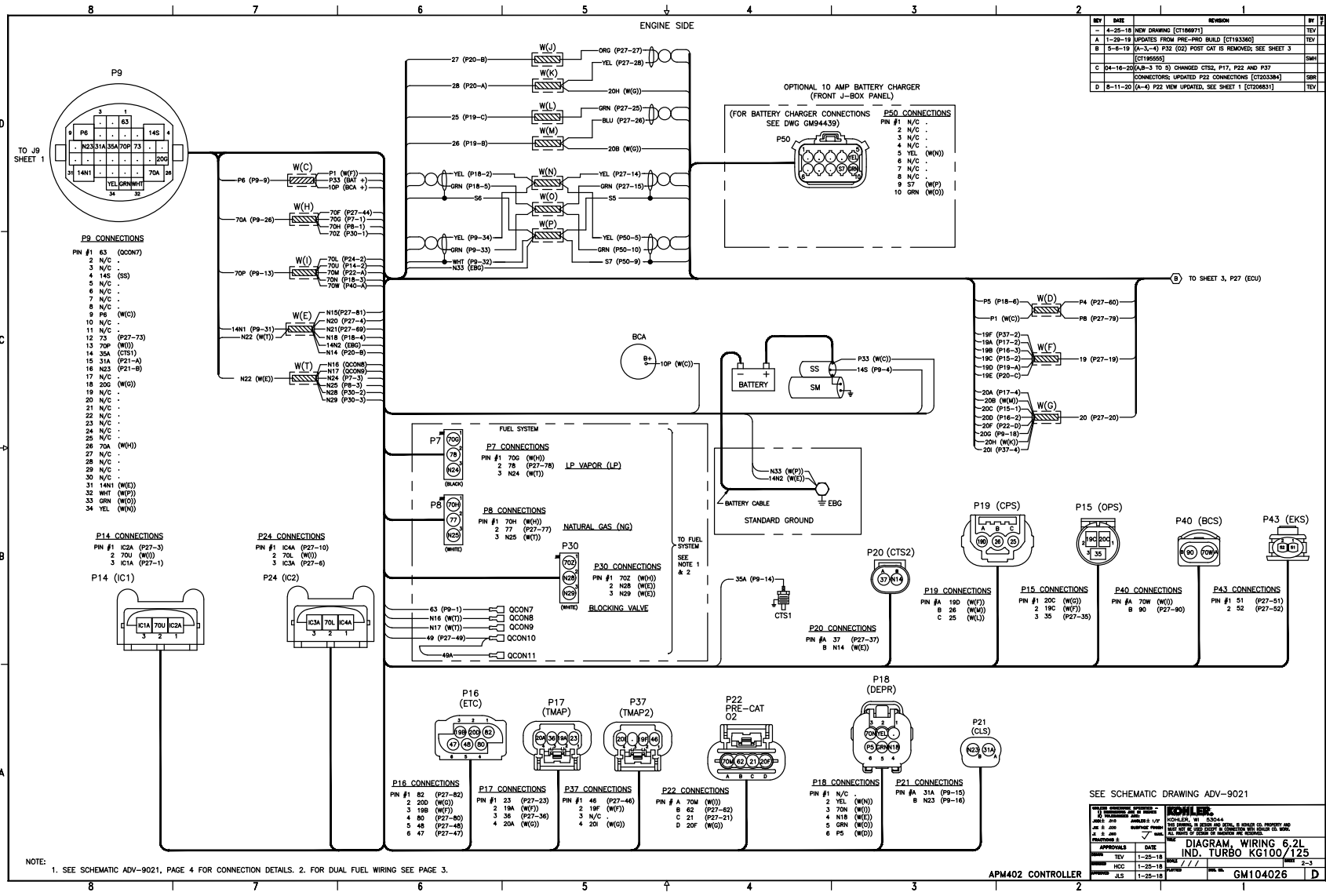

REV	DATE	REVISION	BY
4	25-18	NEW DRAWING (CT180971)	TEV
A	1-28-18	UPDATES FROM PRE-PRO BUILD (CT183360)	TEV
B	5-8-19	[A-3,-4] P32 (O2) POST CAT IS REMOVED; SEE SHEET 3 (CT185565)	SMH
C	04-18-20	[A-B-3 TO 5] CHANGED CTS2, P17, P22 AND P37 CONNECTIONS; UPDATED P32 CONNECTIONS (CT203384)	GRN
D	8-11-20	[A-4] P22 VIEW UPDATED; SEE SHEET 1 (CT208831)	TEV

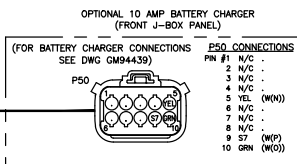

- P9 CONNECTIONS
- | | |
|--------|-------------|
| PIN #1 | 63 (QCON7) |
| 2 | N/C |
| 3 | N/C |
| 4 | 14S (SS) |
| 5 | N/C |
| 6 | N/C |
| 7 | N/C |
| 8 | N/C |
| 9 | FR (W(C)) |
| 10 | N/C |
| 11 | N/C |
| 12 | 75 (P27-73) |
| 13 | 70P (W(I)) |
| 14 | 25A (CTS1) |
| 15 | 31A (P21-A) |
| 16 | N23 (P21-B) |
| 17 | N/C |
| 18 | 20G (W(G)) |
| 19 | N/C |
| 20 | N/C |
| 21 | N/C |
| 22 | N/C |
| 23 | N/C |
| 24 | N/C |
| 25 | N/C |
| 26 | 70A (W(H)) |
| 27 | N/C |
| 28 | N/C |
| 29 | N/C |
| 30 | N/C |
| 31 | 14N1 (W(E)) |
| 32 | WIT (W(P)) |
| 33 | GRN (W(O)) |
| 34 | YEL (W(N)) |

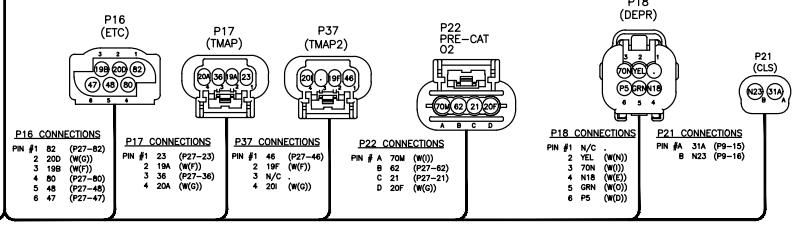
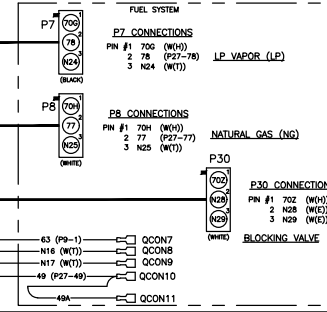
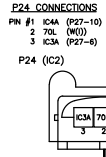
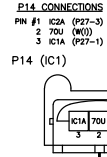

SEE SCHEMATIC DRAWING ADV-9021

APPROVED	DATE	REV	DATE	REV	DATE
TEV	1-25-18	1	1-25-18	1	1-25-18
HCC	1-25-18	2	1-25-18	2	1-25-18
JLS	1-25-18	3	1-25-18	3	1-25-18

DIAGRAM, WIRING 6.2L IND. TURBO KG100/125

APM402 CONTROLLER

GM104026

NOTE: 1. SEE SCHEMATIC ADV-9021, PAGE 4 FOR CONNECTION DETAILS. 2. FOR DUAL FUEL WIRING SEE PAGE 3.

REV	DATE	REVISION	BY
4	25-18	NEW DRAWING (CT168971)	TEV
1	29-18	UPDATES FROM PRE-PRO BUILD (CT153362)	TEV
5	8-19	(A,B-4-5) P27-61 & 22: LEADS 22 & 61 ARE REMOVED; (B,C,D-4 TO-8) DUAL FUEL WIRING IS ADDED; SEE SHEET 2	
		[CT169255]	SMH
C	04-16-20	SEE SHEET 2 (CT203364)	SMH
D	8-11-20	SEE SHEET 1 & 2 (CT208831)	TEV

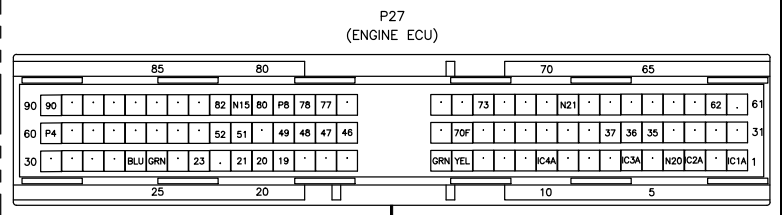
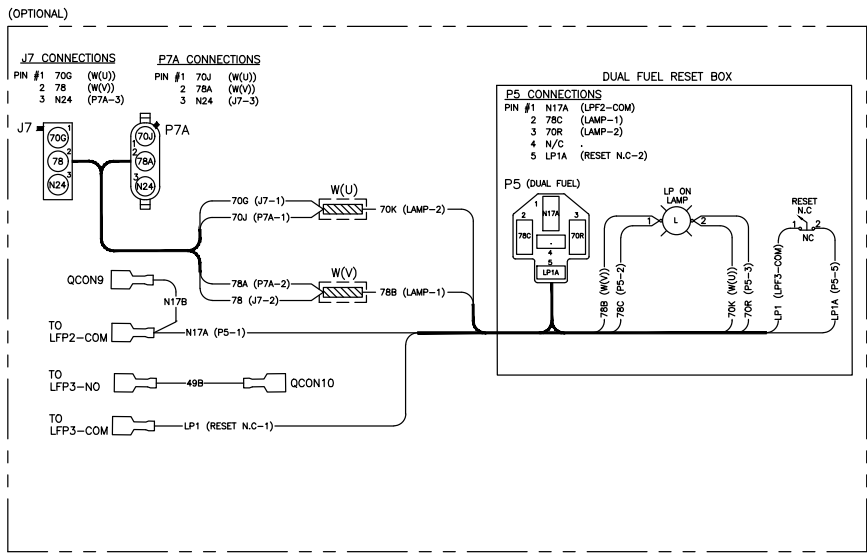

P27 CONNECTIONS

PIN #1	WIRE	CONNECTOR	PIN #46	WIRE	CONNECTOR
1	N/C		46	P37-1	
2	N/C		47	P16-6	
3	ICA2A	(P14-1)	48	P16-5	
4	N20	(W(E))	49	QCON10	
5	N/C		50	N/C	
6	ICA3A	(P24-3)	51	P43-1	
7	N/C		52	P43-2	
8	N/C		53	N/C	
9	N/C		54	N/C	
10	ICA4A	(P24-1)	55	N/C	
11	N/C		56	N/C	
12	N/C		57	N/C	
13	N/C		58	N/C	
14	YEL	(W(N))	59	N/C	
15	GRN	(W(O))	60	P4	(W(D))
16	N/C		61	N/C	
17	N/C		62	P22-B	
18	N/C		63	N/C	
19	W(F)		64	N/C	
20	W(O)		65	N/C	
21	21	(P22-C)	66	N/C	
22	N/C		67	N/C	
23	23	(P17-1)	68	N/C	
24	N/C		69	N21	(W(E))
25	GRN	(W(L))	70	N/C	
26	BLU	(W(M))	71	N/C	
27	N/C		72	N/C	
28	N/C		73	73	(P9-12)
29	N/C		74	N/C	
30	N/C		75	N/C	
31	N/C		76	N/C	
32	N/C		77	77	(P8-2)
33	N/C		78	78	(P7-2)
34	N/C		79	P8	(W(D))
35	35	(P15-3)	80	80	(P16-4)
36	36	(P17-3)	81	N15	(W(E))
37	37	(P20-A)	82	82	(P16-1)
38	N/C		83	N/C	
39	N/C		84	N/C	
40	N/C		85	N/C	
41	N/C		86	N/C	
42	N/C		87	N/C	
43	N/C		88	N/C	
44	70F	(W(H))	89	N/C	
45	N/C		90	90	(P40-B)

TO SHEET 2 (B)

SEE SCHEMATIC DRAWING ADV-9021

APPROVALS		DATE	REV	DATE	REV
TEV	1-25-18	1-25-18	1-25-18	1-25-18	3-3
HCC	1-25-18	1-25-18	1-25-18	1-25-18	3-3
JLS	1-25-18	1-25-18	1-25-18	1-25-18	3-3

DIAGRAM, WIRING 6.2L IND. TURBO KG100/25

APM402 CONTROLLER

GM104026

8

7

6

5

4

3

2

1

P29 2 AMP RELAY OUTPUT (2.1) CONNECTIONS.
 P29-NC 2.1 RELAY NORMALLY CLOSED
 P29-COM 2.1 RELAY COMMON
 P29-NO 2.1 RELAY NORMALLY OPEN

P30 2 AMP RELAY OUTPUT (2.2) CONNECTIONS.
 P30-NC 2.2 RELAY NORMALLY CLOSED
 P30-COM 2.2 RELAY COMMON
 P30-NO 2.2 RELAY NORMALLY OPEN

P31 2 AMP RELAY OUTPUT (2.3) CONNECTIONS.
 P31-NC 2.3 RELAY NORMALLY CLOSED
 P31-COM 2.3 RELAY COMMON
 P31-NO 2.3 RELAY NORMALLY OPEN

P32 10 AMP RELAY OUTPUT (2.4 & 2.5) CONNECTIONS.
 P32-NO 2.4 RELAY NORMALLY OPEN
 P32-COM 2.4 RELAY COMMON
 P32-NC 2.4 RELAY NORMALLY CLOSED
 P32-NO 2.5 RELAY NORMALLY OPEN
 P32-COM 2.5 RELAY COMMON
 P32-NC 2.5 RELAY NORMALLY CLOSED

P27 CAN TERMINATOR CONNECTIONS.
 PLACE THE P27 JUMPER ON THE "IN" PINS

P28 SINGLE-ENDED (0-5V) ANALOG INPUT CONNECTIONS.
 P28-GND AGND ANALOG RETURN
 P28-VN2 NO CONNECTION
 P28-VP2 ACH2 SIGNAL
 P28-+5V SUPPLY (0.05 AMP MAX)
 P28-GND AGND ANALOG RETURN
 P28-VN1 NO CONNECTION
 P28-VP1 ACH1 SIGNAL
 P28-+5V SUPPLY (0.05 AMP MAX)

P28 DIFFERENTIAL (+/-3V) ANALOG INPUT CONNECTIONS.
 P28-GND AGND ANALOG REFERENCE
 P28-VN2 ACH2 NEGATIVE DIFFERENTIAL SIGNAL
 P28-VP2 ACH2 POSITIVE DIFFERENTIAL SIGNAL
 P28-+5V SUPPLY (0.05 AMP MAX)
 P28-GND AGND ANALOG RETURN
 P28-VN1 ACH1 NEGATIVE DIFFERENTIAL SIGNAL
 P28-VP1 ACH1 POSITIVE DIFFERENTIAL SIGNAL
 P28-+5V SUPPLY (0.05 AMP MAX)

NOTE: CONTACT AUTHORIZED DISTRIBUTOR TO DEFINE P28 A/D INPUTS.

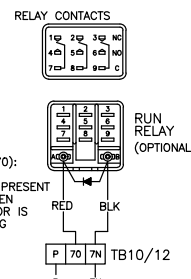

RELAY CONTACTS

TB10-8 (70):
 BATTERY VOLTAGE PRESENT ONLY WHEN GENERATOR IS OPERATING

TB2 NOTE:
 IF SHUNT TRIP OR FAILURE RELAY IS NOT USED, DISCONNECT & TAPE LEADS 2 & 32A.

TB3 NOTE:
 NOTE: TRANSFER SWITCH TERMINAL DESIGNATIONS MAY VARY FROM THOSE SHOWN HERE, VERIFY THE CORRECT DESIGNATIONS USING THE APPROPRIATE TRANSFER SWITCH WIRING DIAGRAM.

(TERMINALS 3 AND 4: REMOTE START SWITCH OR ENGINE START CONTACTS ON TRANSFER SWITCH)

REV	DATE	REVISION	BY
F	04-28-10	(0-2-3) COMMENT "NOT AVAILABLE AS A STANDALONE KIT", "OPTIONAL, INCLUDED IN SHUNT TRIP KIT" ARE ADDED, SEE SHEET 2 (01168997)	SSB
G	2-6-10	[A-B-6, 7, 8] ADDED GROUND FAULT RELAY INPUT; TB1-D11 LOW FUEL PRESSURE WAS EXISTING OVER VOLTAGE (AL3AL2M) [A-B-1, 2, 3] ADDED NOTE 5 AND 6 IN INSTALLATION NOTES (01193015)	SSB

LEGEND
 P(#) - PLUG
 QCON(#)- QUICK CONNECT
 TB(#)- TERMINAL BLOCK
 W(#)- SONIC WELD

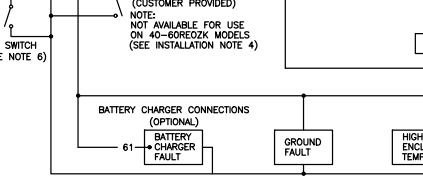
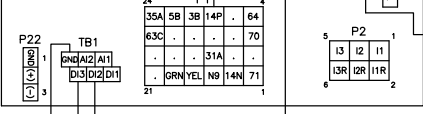
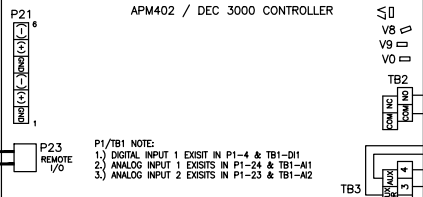
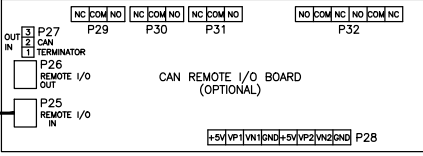

P21 RS485 NON-ISOLATED CONNECTIONS.
 P21-1 GND
 P21-2 +
 P21-3 +
 P21-4 GND
 P21-5 +
 P21-6 -

TB1 ANALOG/DIGITAL INPUT FACTORY SETTINGS
 TB1-D11 DCH1 LOW FUEL PRESSURE
 TB1-D2 DCH2 AUX WARNING
 TB1-D3 DCH3 BATTERY CHARGER FAULT WARNING
 TB1-A1 ACH1 NO FUNCTION
 TB1-A2 ACH2 NO FUNCTION
 TB1-GND A/DGND ANALOG/DIGITAL RETURN

NOTE: TB1 A/D INPUTS MAY BE REDEFINED - FACTORY DEFAULTS LISTED. CONTACT AUTHORIZED DISTRIBUTOR FOR DETAILS.

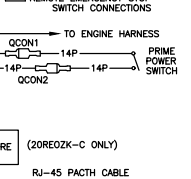

TB2 RELAY OUTPUT
 TB2-D11 DCH1 COMMON FAULT
 TB2-COM (RELAY COMMON) COMMON FAULT
 TB2-NO (RELAY NORMALLY OPEN) COMMON FAULT
 TB2-NC (RELAY NORMALLY CLOSED) COMMON FAULT

NOTE: TB2 RELAY OUTPUT MAY BE REDEFINED - FACTORY DEFAULTS LISTED. CONTACT AUTHORIZED DISTRIBUTOR FOR DETAILS. CUSTOMER TO CONNECT TO TB2 UNLESS SHUNT TRIP IS USED. IF SHUNT TRIP IS USED, CUSTOMER TO CONNECT TO DCB2 FOR COMMON FAULT.

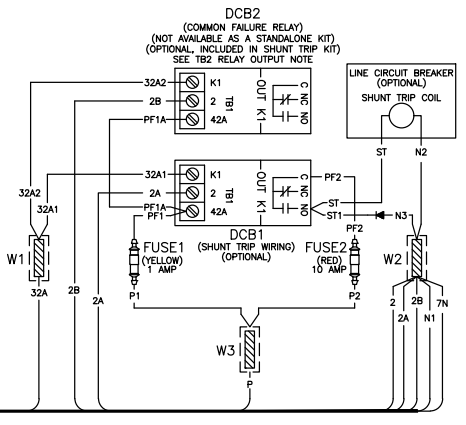

INSTALLATION NOTES:

- FOR FIELD INSTALLATION A MAXIMUM OF TWO WIRE TERMINALS PER TERMINAL STRIP SCREW IS RECOMMENDED UNLESS OTHERWISE NOTED ON THE WIRING DIAGRAM. DO NOT EXTEND ABOVE THE TERMINAL STRIP BARRIER.
- GENERATOR SETS WITH FUEL TANKS HAVE THE FUEL IN BASIN SWITCH TIED TO DIGITAL INPUT 1 (TB1-D11) VIA P1-4 AND FUEL LEVEL SENDER TIED TO ANALOG INPUT 2 (TB1-AI2) VIA P1-23
- COOLANT LEVEL SENSOR ON ALL GENSETS IS TIED TO ANALOG INPUT 1 (TB1-AI2) VIA P1-24.
- 40-60 REOZK MODELS HAVE COLD START IGNITION RELAY TIED TO DIGITAL INPUT 2 (TB1-DI2)
- GROUND FAULT WARNING : CONNECT TO REMOTE I/O BOARD ON 20REOZK-C.
- KEYSWITCH AVAILABLE ON SELECT MODELS ONLY.

DATE	BY	REV	DESCRIPTION
09-16-10	CMS	1	ISSUED
09-16-10	DPS	2	REVISED
09-16-10	CMS	3	REVISED

DIAGRAM, DEC3000/APM402 ACCY INTERCONNECTION

GM78246 D

APM402 / DEC 3000 ACCESSORIES

8

7

6

5

4

3

2

1

REV	DATE	REVISION	BY
F	04-28-18	(8-6-2) COMMENT "APM402 / DEC 3000 ACCESSORIES" IS ADDED	SRH
		SEE SHEET 1 (C118097)	SRH
G	2-6-19	SEE SHEET 1 (C1182515)	SRH

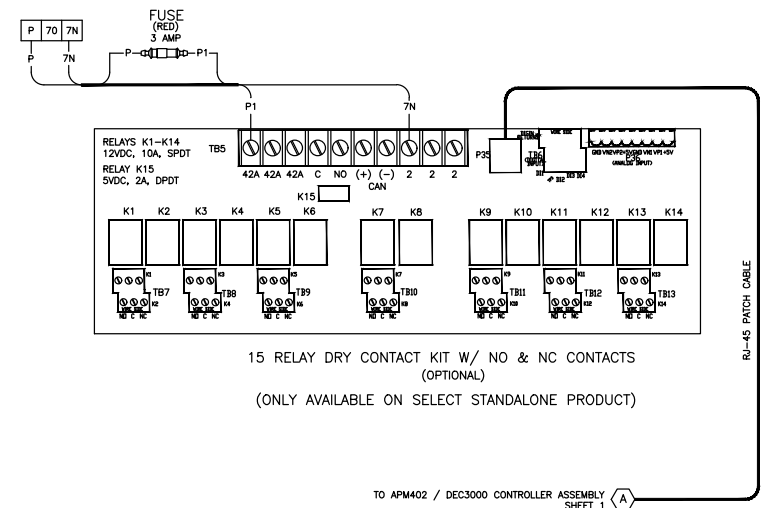
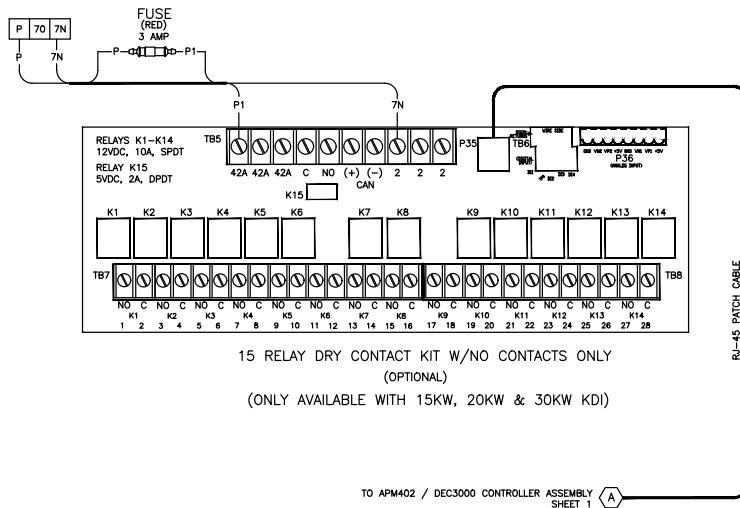

APM402 / DEC 3000 ACCESSORIES

KOHLER CO. POWER SYSTEMS DIVISION, 10000 N. 30TH AVE., U.S.A. 48062-2010 PHOENIX, AZ 85026 CO. REG. NO. 1000000000000000 ALL RIGHTS OF OTHERS OR INVENTION ARE RESERVED.	
APPROVALS DESIGNED BY: DFS CHECKED BY: CRS DATE: 9-18-15	DATE: 9-18-15 DRAWN BY: DFS DATE: 9-18-15 PART NO.: GM78246
DIAGRAM, DEC3000/APM402 ACCY INTERCONNECTION	

KOHLER®

Miscellaneous

OVERVIEW:
 THE AUTOMATIC MULTI-LEVEL FLOAT/ EQUALIZE CHARGER SPECIFIED BELOW IS INTENDED TO CHARGE ENGINE STARTING BATTERIES EITHER INDEPENDENT OR IN CONJUNCTION WITH AN ENGINE DRIVEN CHARGING SYSTEM.

BATTERY TYPES TO BE CHARGED:

- LEAD ACID
- AGM
- GEL CELL
- HIGH PERFORMANCE AGM
- FLOODED
- NICKEL CADMIUM (NiCd)

INPUT AC:

INPUT VOLTAGE: 90-265V SINGLE PHASE
 INPUT FREQUENCY: 47-63 Hz

INPUT LEAD:

APPROXIMATELY 1.8M (72") (REF) TYPE SJTOW -40°C TO 105°C UL RATED WIRE AND INSULATION. TERMINATED IN PRE-MOLDED UL RATED 3 PRONG NEMA 5-15 MALE AC PLUG.

DC OUTPUT:

10A @ 12V
 10A @ 24V
 VOLTAGE REGULATION: +/-1% (VOLTAGE AT EACH STAGE IS TOPOLOGY DEPENDENT)

OUTPUT LEAD:

APPROX. 1.8M (72") (REF) TYPE SJT00W -40°C TO 105°C UL RATED WIRE WITH RED AND BLACK WIRE INSULATION. TERMINATED IN 9.5 mm (REF) RING STYLE TERMINALS.

FUSES:

THE FUSE MUST BE LOCATED APPROXIMATELY 6" FROM RING TERMINAL ON RED OUTPUT LEAD.
 20A ATC

ENVIRONMENTAL:

STORAGE TEMPERATURE RANGE: -40 TO +85°C (-40 TO +185°F)
 OPERATING TEMPERATURE RANGE: -20 TO +70°C (-4 TO +158°F)
 HUMIDITY: 5 TO 95% (NON-CONDENSING)
 SALT SPRAY TESTING - ASTM B117
 CORROSION RESISTANT FROM GASSING OF BATTERIES

REVERSE POLARITY PROTECTION:

THE CHARGER SHALL SUSTAIN NO DAMAGE WHEN INCORRECTLY CONNECTED TO THE BATTERY IN REVERSE ORIENTATION.

MOUNTING:

4 NON-THREADED THROUGH HOLES FOR M6 FASTENERS TO PASS THROUGH

ENCLOSURE:

SHALL PROTECT THE CHARGER COMPONENTS FROM RAIN, SNOW, DUST AND DRIPPING WATER AND UNINTENTIONAL IMPACTS. ALL INTERNAL COMPONENTS PROTECTED FROM WATER DROPLETS.

INDICATORS:

POWER: INDICATES THE ACCEPTABILITY OF AC INPUT TO THE CHARGER
 COMMUNICATION: INDICATES THE STATE OF THE COMMUNICATION SYSTEM
 TEMPERATURE COMPENSATION: INDICATES THE STATE OF THE TEMPERATURE COMPENSATION SUBSYSTEM WHEN INSTALLED
 VOLTAGE OUTPUT: INDICATES THE STATE OF THE BATTERY AND CERTAIN FAULT CONDITIONS.

DOCUMENTATION:

THERE SHALL BE AN INSTALLATION / OPERATIONAL MANUAL SUPPLIED WITH EACH CHARGER. PER KOHLER SUPPLIED ARTWORK.

CERTIFICATIONS (US AND CANADA):

- UL1236
- CSA - C22.2 NO 107.2-01
- FCC- TITLE 47, PART 15 CLASS A
- CE
- EN 61000-6-2
- CEC AND DOE
- NFPA-110 LEVEL 1 (WHEN SUPPORTED WITH APPLICABLE KOHLER CONTROLLER)
- IBC

PRODUCT LABELING:

THE LABEL ATTACHED TO THE CHARGER SHALL HAVE THE FOLLOWING INFORMATION:
 UL LISTING
 KOHLER PART NUMBER
 DESCRIPTION OF ALL INDICATOR
 OUTPUT CURRENT AND VOLTAGE
 INPUT VOLTAGE AND FREQUENCY

PACKAGING LABEL:
 THE PACKAGING LABEL SHALL CONTAIN THE FOLLOWING INFORMATION:
 KOHLER P/N
 DESCRIPTION - BATTERY CHARGER
 MFG. MODEL NO
 MFG. PART NUMBER
 DATE CODE

WARRANTY:
 2 YEAR FROM DATE OF PURCHASE FROM MANUFACTURE.

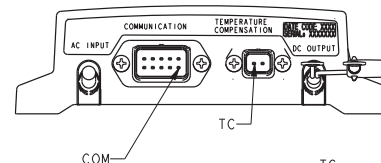
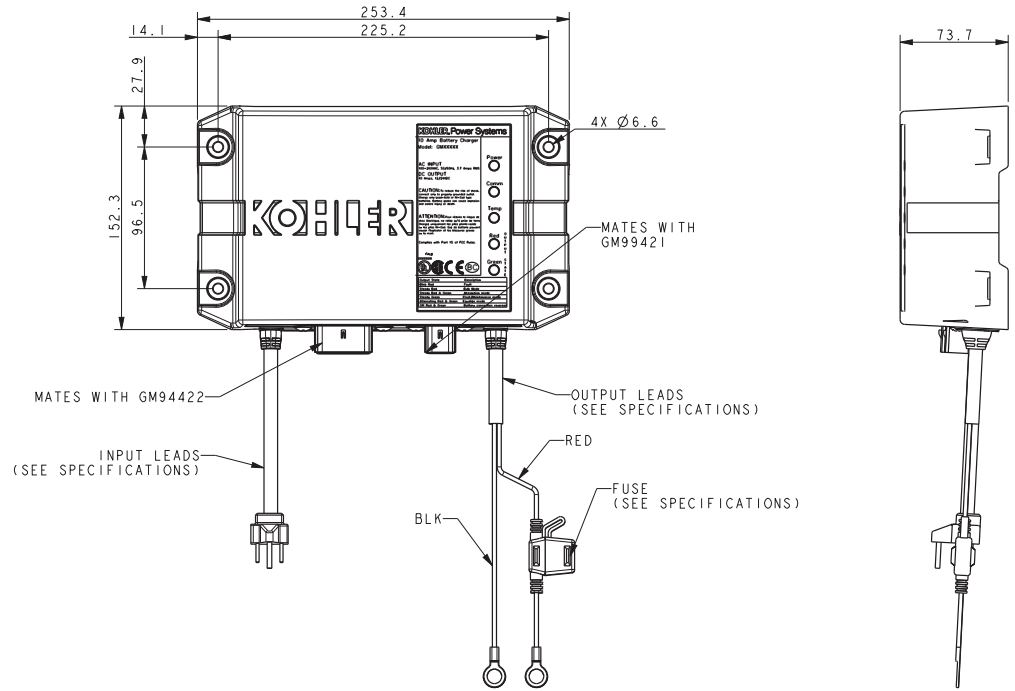

- COM PIN 1 N/C
 2 ID SEL 1
 3 ID SEL 2
 4 N/C
 5 CAN-H
 6 N/C
 7 ID SEL 1 RTN
 8 ID SEL 2 RTN
 9 CAN-GND
 10 CAN-L
- I.C. PIN 1 TC SENSOR W1
 2 TC SENSOR W2

REV	DATE	ON COMPOSITE DWGS. SEE PART NO. FOR REVISION LEVEL	BY	UNLESS OTHERWISE SPECIFIED: 1) DIMENSIONS ARE IN MILLIMETERS 2) TOLERANCES ARE: X .XX ± 0.25 Y .Y ± 0.5 ANGLES ± 0° 30' MAX.
-	9-22-14	NEW DRAWING [CT91634]	SAM	
A	5-9-17	(C-4, 2) MATING NOTE ADDED (A-2, 4) PIN CONNECTIONS ADDED [CT174256]	SAM	

APPROVALS	DATE	TITLE
DRAWN: SAM	9-22-14	CHARGER, BATTERY 10 AMP
CHECKED: SAM	9-22-14	SCALE: 0.50 CAD NO. SHEET 1 of 1
APPROVED: AGT	9-22-14	DWG NO. GM87448

KIT NUMBER	VIEW	DESCRIPTION
GM94447-KA1	VIEW 1&3	BATTERY CHARGER, FLOAT 12V/24V 10A
GM94447-KA2	VIEW 2	BATTERY CHARGER, FLOAT 24V 10A

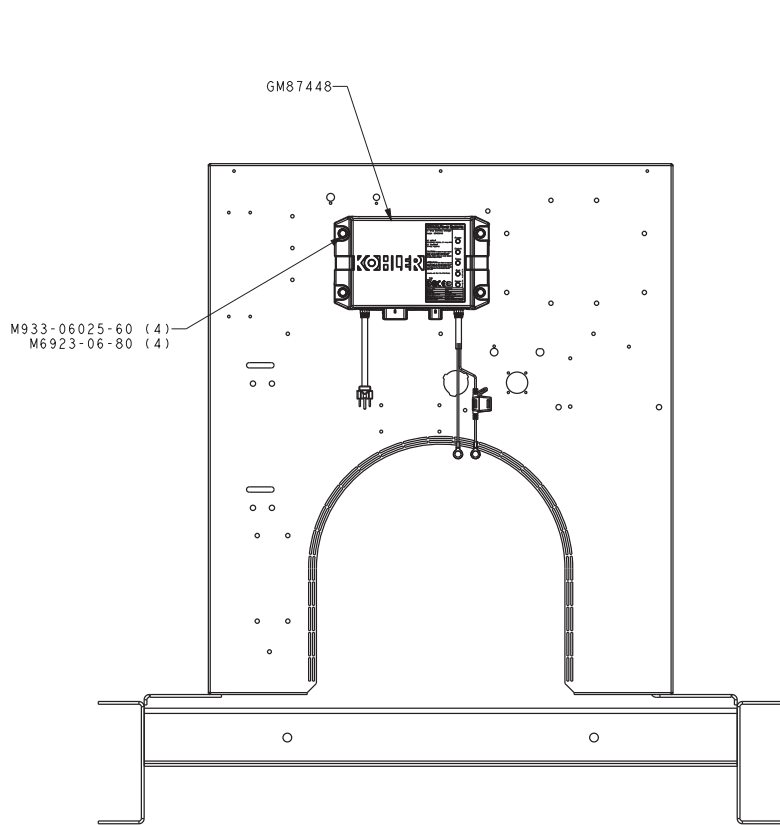

VIEW 1

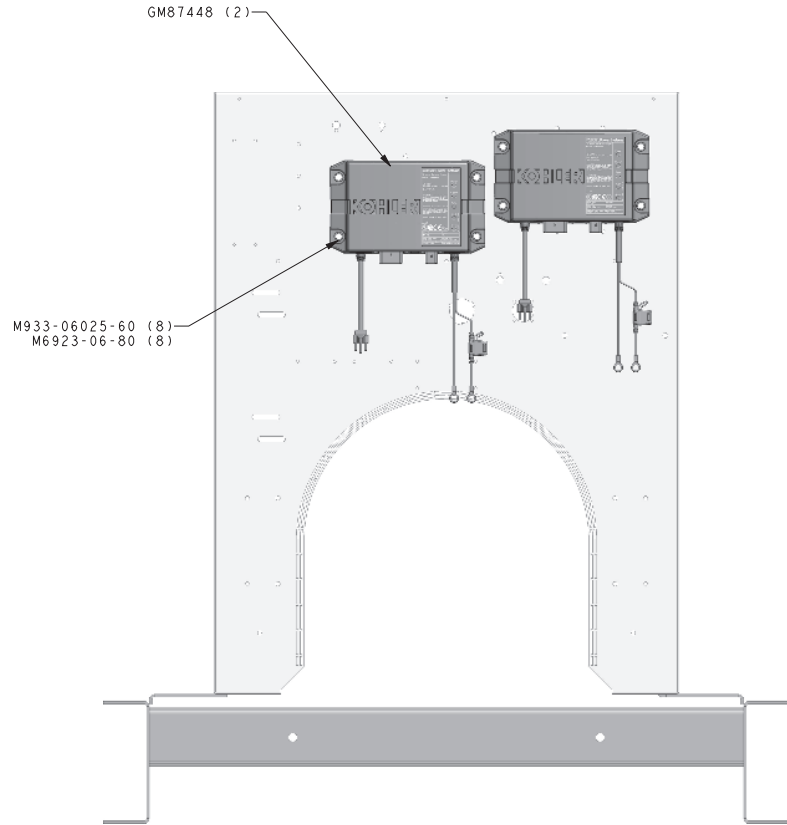

VIEW 2

NOTE:
FOR PROPER ASSEMBLY METHOD OF HARDWARE, USE G-585 AS A GUIDELINE.
THIS ASSEMBLY OR PART MUST COMPLY WITH PEP-RML-001

REV	DATE	ON COMPOSITE DWGS. SEE PART NO. FOR REVISION LEVEL	BY	UNLESS OTHERWISE SPECIFIED: 2) DIMENSIONS ARE IN MILLIMETERS	KOHLER CO. METRIC PRO-E
-	9-23-14	NEW DRAWING [CT94502]	SAM	2) TOLERANCES ARE: FRACTIONS: ± 0.25 DECIMALS: ± 0.13	POWER SYSTEMS, KOHLER, WI 53044 U.S.A. THIS DRAWING IN DESIGN AND DETAIL IS KOHLER CO. PROPERTY AND MUST NOT BE USED EXCEPT IN CONNECTION WITH KOHLER CO. WORK. ALL RIGHTS OF DESIGN OR INVENTION ARE RESERVED.
A	2-16-18	SHEET 2 ADDED; SEE SHEET 2 [CT184382]	KRM	3) SURFACE FINISH ANGLES ± 0° 30' MAX.	DWG, ASSY BATTERY CHARGER SCALE 0.40 CAD NO. SHEET 1 of 2 DWG NO. GM94447
B	04MAY2022	(D-7) GM94447-KA1 DESCRIPTION UPDATED, (A-3)	PBC		
		PEP-RML-001 NOTE ADDED [CT219524]			
				APPROVALS	
				DATE	
				9-23-14	
				9-23-14	
				9-23-14	

KOHLER®

Warranty

Stationary Standby and Prime Power Industrial Generator Set One-Year or Two Thousand (2000)-Hour Limited Warranty

Your Kohler product has been manufactured and inspected with care by experienced craftsmen. If you are the original end user, Kohler Co. warrants, for the period indicated below, each product to be free from defects in materials and workmanship. In the event of a defect in materials or workmanship, Kohler Co. will repair, replace, or make appropriate adjustment at Kohler Co.'s option if the product, upon Kohler Co.'s inspection, is found to be properly installed, maintained, and operated in accordance with Kohler Co.'s instruction manuals. A Kohler distributor, dealer, or authorized service representative must perform startup.

Kohler Product

Stationary Standby Generator Set & Accessories

Warranty Coverage

One (1) year from registered startup or two thousand (2000) hours (whichever occurs first). In any event, the warranty period will expire not later than thirty (30) months from the date of shipment from Kohler Co.'s factory.

Stationary Prime Power Generator Set & Accessories

One (1) year from registered startup or two thousand (2000) hours (whichever occurs first). In any event, the warranty period will expire not later than thirty (30) months from the date of shipment from Kohler Co.'s factory.

The following will **not** be covered by the warranty:

1. Normal wear, routine tuneups, tuneup parts, adjustments, and periodic service.
2. Damage, including but not limited to damage caused by accidents, improper installation or handling, faulty repairs not performed by an authorized Kohler service representative, improper storage, or acts of God.
3. Damage caused by operation at speeds, or with fuel, loads, conditions, modifications or installation contrary to published specifications.
4. Damage caused by negligent maintenance such as:
 - a. Failure to provide the specified type and sufficient quantity of lubricating oil.
 - b. Failure to keep the air intake and cooling fin areas clean.
 - c. Failure to service the air cleaner.
 - d. Failure to provide sufficient coolant and/or cooling air.
 - e. Failure to perform scheduled maintenance as prescribed in supplied manuals.
 - f. Failure to regularly exercise the generator set under load (stationary applications only).
5. Original installation charges and startup costs.
6. Starting batteries and the following related expenses:
 - a. Labor charges related to battery service.
 - b. Travel expenses related to battery service.
7. Additional expenses for repairs performed after normal business hours, i.e. overtime or holiday labor rates.
8. Rental of equipment during the performance of warranty repairs.
9. Removal and replacement of non-Kohler-supplied options and equipment.
10. Non-Kohler replacement parts. Replacement of a failed Kohler part with a non-Kohler part voids the warranty on that part.
11. Radiators replaced rather than repaired.
12. Fuel injection pumps not repaired by an authorized Kohler service representative.
13. Non-Kohler-authorized repair shop labor without prior approval from Kohler Co. Warranty Department.
14. Engine fluids such as fuel, oil, or coolant/antifreeze.
15. Shop supplies such as adhesives, cleaning solvents, and rags.
16. Expenses incurred investigating performance complaints unless the problem is caused by defective Kohler materials or workmanship.
17. Maintenance items such as fuses, lamps, filters, spark plugs, loose or leaking clamps, and adjustments.
18. Travel time and mileage exceeding 300 miles round trip.

To obtain warranty service, call 1-800-544-2444 for your nearest authorized Kohler service representative or write Kohler Co., Service Department, MS072, Kohler, WI 53044 USA.

KOHLER CO. SHALL NOT BE LIABLE FOR SPECIAL, INCIDENTAL, AND/OR CONSEQUENTIAL DAMAGES OF ANY KIND including, but not limited to, incidental and/or consequential labor costs, installation charges, telephone charges, or transportation charges in connection with the replacement or repair of defective parts.

This is our exclusive written warranty. We make no other express warranty nor is anyone authorized to make any on our behalf.

ANY IMPLIED OR STATUTORY WARRANTY, INCLUDING ANY WARRANTY OF MERCHANTABILITY OR FITNESS FOR A PARTICULAR PURPOSE, IS EXPRESSLY LIMITED TO THE DURATION OF THIS WARRANTY. Some states do not allow limitations on how long an implied warranty lasts, or the exclusion or limitation of incidental and/or consequential damages, so the above limitation or exclusion may not apply to you.

This warranty gives you specific legal rights, and you may also have other rights which vary from state to state.

KOHLER®

KOHLER CO., Kohler, Wisconsin 53044
Phone 920-457-4441, Fax 920-459-1646
For the nearest sales/service outlet in the US and Canada, phone 1-800-544-2444
KOHLERPower.com

TP-5374 12/15f

Stationary Standby Industrial Generator Set Extended Five-Year or Three Thousand (3000)-Hour Comprehensive Limited Warranty

Your Kohler product has been manufactured and inspected with care by experienced craftsmen. If you are the original end user, Kohler Co. warrants, for the period indicated below, each product to be free from defects in materials and workmanship. In the event of a defect in materials or workmanship, Kohler Co. will repair, replace, or make appropriate adjustment at Kohler Co.'s option if the product, upon Kohler Co.'s inspection, is found to be properly installed, maintained, and operated in accordance with Kohler Co.'s instruction manuals. A Kohler distributor, dealer, or authorized service representative must perform startup.

Kohler Product

Stationary Standby Generator Set & Accessories

Warranty Coverage

Five (5) years from registered startup or three thousand (3000) hours (whichever occurs first).

This warranty is effective only upon Kohler Co.'s receipt of an extended warranty registration form and warranty fee within one year of registered startup. The comprehensive limited warranty start date is determined by the standard limited warranty requirements and runs concurrent with the standard limited warranty during the first year. To receive extended comprehensive limited warranty coverage, the provisions of the standard limited warranty registration must be met.

The following will **not** be covered by the warranty:

1. Normal wear, routine tuneups, tuneup parts, adjustments, and periodic service.
2. Damage, including but not limited to damage caused by accidents, improper installation or handling, faulty repairs not performed by an authorized Kohler service representative, improper storage, or acts of God.
3. Damage caused by operation at speeds, or with fuel, loads, conditions, modifications or installation contrary to published specifications.
4. Damage caused by negligent maintenance such as:
 - a. Failure to provide the specified type and sufficient quantity of lubricating oil.
 - b. Failure to keep the air intake and cooling fin areas clean.
 - c. Failure to service the air cleaner.
 - d. Failure to provide sufficient coolant and/or cooling air.
 - e. Failure to perform scheduled maintenance as prescribed in supplied manuals.
 - f. Failure to regularly exercise the generator set under load (stationary applications only).
5. Original installation charges and startup costs.
6. Starting batteries and the following related expenses:
 - a. Labor charges related to battery service.
 - b. Travel expenses related to battery service.
7. Engine coolant heaters, heater controls, and circulating pumps after the first year of the warranty period.
8. Additional expenses for repairs performed after normal business hours, i.e. overtime or holiday labor rates.
9. Rental of equipment during the performance of warranty repairs.
10. Removal and replacement of non-Kohler-supplied options and equipment.
11. Non-Kohler replacement parts. Replacement of a failed Kohler part with a non-Kohler part voids the warranty on that part.
12. Radiators replaced rather than repaired.
13. Fuel injection pumps not repaired by an authorized Kohler service representative.
14. Non-Kohler-authorized repair shop labor without prior approval from Kohler Co. Warranty Department.
15. Engine fluids such as fuel, oil, or coolant/antifreeze.
16. Shop supplies such as adhesives, cleaning solvents, and rags.
17. Expenses incurred investigating performance complaints unless the problem is caused by defective Kohler materials or workmanship.
18. Maintenance items such as fuses, lamps, filters, spark plugs, loose or leaking clamps, and adjustments.
19. Travel time and mileage exceeding 300 miles round trip.

To obtain warranty service, call 1-800-544-2444 for your nearest authorized Kohler service representative or write Kohler Co., Service Department, MS072, Kohler, WI 53044 USA.

KOHLER CO. SHALL NOT BE LIABLE FOR SPECIAL, INCIDENTAL, AND/OR CONSEQUENTIAL DAMAGES OF ANY KIND including, but not limited to, incidental and/or consequential labor costs, installation charges, telephone charges, or transportation charges in connection with the replacement or repair of defective parts.

This is our exclusive written warranty. We make no other express warranty nor is anyone authorized to make any on our behalf.

ANY IMPLIED OR STATUTORY WARRANTY, INCLUDING ANY WARRANTY OF MERCHANTABILITY OR FITNESS FOR A PARTICULAR PURPOSE, IS EXPRESSLY LIMITED TO THE DURATION OF THIS WARRANTY. Some states do not allow limitations on how long an implied warranty lasts, or the exclusion or limitation of incidental and/or consequential damages, so the above limitation or exclusion may not apply to you.

This warranty gives you specific legal rights, and you may also have other rights which vary from state to state.

KOHLER®

KOHLER CO., Kohler, Wisconsin 53044
Phone 920-457-4441, Fax 920-459-1646
For the nearest sales/service outlet in the
US and Canada, phone 1-800-544-2444
KOHLERPower.com

TP-5561 8/16f

KOHLER®

Certification

Certificate of Registration

QUALITY MANAGEMENT SYSTEM - ISO 9001:2015

This is to certify that:

Kohler Power Systems
N7650 Lakeshore Road
Sheboygan
Wisconsin
53083
USA

Holds Certificate No:

FM 727336

and operates a Quality Management System which complies with the requirements of ISO 9001:2015 for the following scope:

Design, manufacture, and distributor support for electrical generators, alternators, fuel tanks, automatic transfer switches and switchgear.

For and on behalf of BSI:



Carlos Pitanga, Chief Operating Officer Assurance – Americas

Original Registration Date: 1995-02-28

Latest Revision Date: 2021-10-29

Effective Date: 2021-11-07

Expiry Date: 2024-11-06

Page: 1 of 2



...making excellence a habit.™

Certificate No: **FM 727336**

Location	Registered Activities
Kohler Power Systems - GK 900 Highland Drive Bldg 604 Kohler Wisconsin 53004 USA	Manufacture of leads and harness, automatic transfer switches and switchgear. Distribution of generator sets.
Kohler Power Systems N7650 Lakeshore Road Sheboygan Wisconsin 53083 USA	Design, manufacture, and distributor support for electrical generators, automatic transfer switches and switchgear.
Kohler Power Systems 300 N Dekora Woods Blvd Saukville Wisconsin 53080 USA	Manufacture of fuel tanks, skids, fabricated components and generators.
Kohler Power Systems Muth Warehouse 2821 Muth Court Sheboygan Wisconsin 53083 USA	The distribution of generator sets.
Kohler Power Systems KWIP Warehouse 4327 County EE Sheboygan Wisconsin 53081 USA	Receiving, sequencing and warehousing of generator components.

Original Registration Date: 1995-02-28

Latest Revision Date: 2021-10-29

Effective Date: 2021-11-07

Expiry Date: 2024-11-06

Page: 2 of 2

PROTOTYPE TEST REPORT



Models Covered: **KG100**
Model Tested: **KG100**
Cooling System Tested: **50C**

Alternator Tested: **4R9X**
Engine Tested: **KG6.2L TA**
Voltage Tested: **480V**

GENSET

Maximum power test to assure that the prime mover and alternator have sufficient capacity to operate within specifications.

Meets Rated Load

Steady-state load test to ensure voltage stability meets or exceed ISO8528-5 requirements and to verify compliance with steady state speed control specifications.

Natural Gas

± 1.00 % Frequency Band **± 0.50 %** Voltage Deviation

LP Gas

± 1.00 % Frequency Band **± 0.50 %** Voltage Deviation

Transient load tests per NEMA MG1-32.18, and ISO 8528 to verify specifications of transient voltage regulation, voltage dip, voltage overshoot, recovery voltage, and recovery time. Values shown for model tested above. Please contact factory for additional details.

Natural Gas

Full Load Acceptance

45.2 % Voltage Dip
1.39 Seconds of Recovery Time
27.7 % Frequency Dip
2.33 Seconds of Recovery Time

G2 ISO8528-5 Class (G1, G2, G3)

Full Load Rejection

15.6 % Voltage Overshoot
0.62 Seconds of Recovery Time
7.39 % Frequency Overshoot
3.68 Seconds of Recovery Time

LP Gas

Full Load Acceptance

43.9 % Voltage Dip
5.37 Seconds of Recovery Time
26.9 % Frequency Dip
11.0 Seconds of Recovery Time

G2 ISO8528-5 Class (G1, G2, G3)

Full Load Rejection

15.3 % Voltage Overshoot
0.63 Seconds of Recovery Time
10.3 % Frequency Overshoot
3.71 Seconds of Recovery Time

PROTOTYPE TEST REPORT



Models Covered: **KG100**
Model Tested: **KG100**
Cooling System Tested: **50C**

Alternator Tested: **4R9X**
Engine Tested: **KG6.2L TA**
Voltage Tested: **480V**

GENSET

NFPA 110 one step testing to determine the amount of time required for the generator set to reach 90% voltage and frequency to allow the ATS to transfer.

Complies with NFPA 110 Type 10

Vibrational analysis, to verify that generator vibrations are within acceptable limits per ISO 8528-9.

Complies

Torsional analysis data, to verify torsional effects are not detrimental and that the generator set will provide dependable service as specified.

Complies

Generator set cooling and air flow tests to verify maximum operating ambient temperature. (Cooling system test results are available on TIB-118)

Acoustical noise intensity and sound attenuation effects tests. (Acoustical noise results are available on TIB-114 &115)

Exhaust Back Pressure test completed to demonstrate within engine limitation (Exhaust back pressure test results are available on TIB-119)

ALTERNATOR

Alternator temperature rise test per NEMA MG1-32.6. Standby and prime ratings of the alternator are established during this test.

Alternator overload test per NEMA MG1-32.8. Motor starting tests per NEMA MG1-32.18.5 to evaluate capabilities of generator, exciter, and regulator system.

Three-phase symmetrical short-circuit test per NEMA MG1-32.13 to demonstrate short circuit performance, mechanical integrity, ability to sustain short-circuit current.

Harmonic analysis, voltage waveform deviation per NEMA MG1-32.10 to confirm that the generator set is producing clean voltage within acceptable limits.

(Alternator detailed test results are available on TIB-102)

Kohler Standby/Prime Generator Set Test Program

Testing is an integral part of quality assurance. In keeping with our uncompromising commitment to quality, safety, and reliability, every Kohler Standby/Prime power generator set undergoes an extensive series of prototype and production testing.

Prototype Testing

Prototype testing includes the potentially destructive tests necessary to verify design, proper function of protective devices and safety features, and reliability expectations. Kohler's prototype testing includes the following:

- Alternator temperature rise test per NEMA MG1-32.6. Standby and prime ratings of the alternator are established during this test.
- Maximum power test to assure that the prime mover and alternator have sufficient capacity to operate within specifications.
- Alternator overload test per NEMA MG1-32.8.
- Steady-state load test to ensure voltage regulation meets or exceeds ANSI C84.1, NEMA MG1-32.17 requirements and to verify compliance with steady-state speed control specifications.
- Transient test to verify speed controls meets or exceeds specifications.
- Transient load tests per NEMA MG1-32.18, and ISO 8528 to verify specifications of transient voltage regulation, voltage dip, voltage overshoot, recovery voltage, and recovery time.
- Motor starting tests per NEMA MG1-32.18.5 to evaluate capabilities of generator, exciter, and regulator system.
- Three-phase symmetrical short-circuit test per NEMA MG1-32.13 to demonstrate short circuit performance, mechanical integrity, ability to sustain short-circuit current.
- Harmonic analysis, voltage waveform deviation per NEMA MG1-32.10 to confirm that the generator set is producing clean voltage within acceptable limits.

Torsional analysis data, to verify torsional effects are not detrimental and that the generator set will provide dependable service as specified, is available upon request.

Kohler offers other testing at the customer's request at an additional charge. These optional tests include power factor testing, customized load testing for specific application, witness testing, and a broad range of MIL-STD-705c testing. A certified test report is also available at an additional charge.

- Generator set cooling and air flow tests to verify maximum operating ambient temperature.
- Reliability tests to demonstrate product durability, followed by root cause analysis of discovered failures and defects. Corrective action is taken to improve the design, workmanship, or components.
- Acoustical noise intensity and sound attenuation effects tests.

Production Testing

In production, Kohler Standby/Prime generator sets are built to the stringent standards established by the prototype program. Every Kohler generator set is fully tested prior to leaving the factory. Production testing includes the following:

- Stator and exciter winding high-potential test on all generators. Surge transient tests on stators for generators 180 kW or larger. Continuity and balance tests on all rotors.
- One-step, full-load pickup tests to verify that the performance of each generator set, regulator, and governor meets published specifications.
- Regulation and stability of voltage and frequency are tested and verified at no load, 1/4 load, 1/2 load, 3/4 load, and full-rated load.
- Voltage, amperage, frequency and power output ratings verified by full-load test.
- The proper operation of controller logic circuitry, prealarm warnings, and shutdown functions is tested and verified.
- Any defect or variation from specification discovered during testing is corrected and retested prior to approval for shipment to the customer.

KOHLER[®]

KOHLER CO. Kohler, Wisconsin 53044
Phone 920-565-3381, Fax 920-459-1646
For the nearest sales/service outlet in the
US and Canada, phone 1-800-544-2444
KohlerPowerSystems.com