

# MASTERPACT® Universal Power Circuit Breaker

Class 631



## CONTENTS

Description	Page
Introduction .....	1
Advantages .....	3
Description .....	6
Control Units .....	7
Accessories .....	23
Switch .....	36
Trip Curves .....	37
Wiring Diagrams .....	42
Circuit Breaker Dimensions .....	46
Appendix .....	62

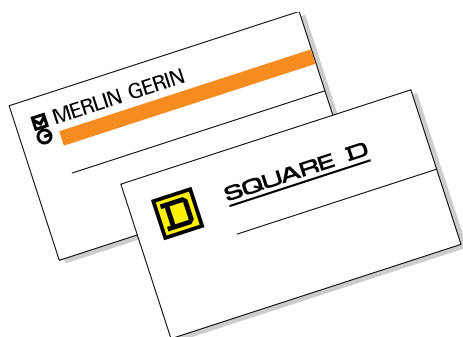

**SQUARE D**  
GROUPE SCHNEIDER

**Standard Compliance**

- UL489: MP08 to MP50 circuit breakers and their accessories are Listed under UL files E63335, E103955 and E113555
- UL1066/ANSI: MC08 to MC50 circuit breakers are UL Listed according to UL1066 (ANSI C37-13) under file E161835
- International Standards: the MASTERPACT® circuit breaker has been designed to meet all the major standards including:
  - IEC 947-2 and related standards such as VDE, BS, EN, etc.
  - JEC, JIS
- UL 1008: MP12, MP20 and MP30 circuit breakers are suitable for use in transfer switch equipment
- Marine Applications:
  - Homologated by Bureau Veritas
  - Approved by Det Norske Veritas and Germanische Lloyd's
  - Listed by Lloyd's Register of Shipping
  - American Bureau of Shipping application
  - UL marine

**High Short-time Current Rating: Up to 100 kA for 1 sec.**

The exceptional short-time rating of 75,000 A in a 3000 A frame and 100,000 A in a 4000 A frame and above allows the circuit breakers to be fully selective up to their interrupting ratings.

**100% Rated**

The circuit breakers are designed for continuous operation at 100% of their current rating.

**Other Performances**

The UL 489 and UL1066 (ANSI C37-13) standard performance tests assure that the circuit breaker has sufficient characteristics to be used in normal conditions. However, the circuit breaker exceeds, without additional costs, the UL standard 1,500 operations required in endurance. The heavy-duty mechanism and the contact design provide a mechanical endurance of 10,000 operations (approx.) without maintenance (see page 64).

**Tropicalization**

The standard moisture and fungus protection ensure normal operation under extreme ambient conditions. MASTERPACT circuit breakers comply with T2 tropicalization (IEC Standard 68-2-30); relative humidity 95% at 113°F (45°C) and 80% at 131°F (55°C) (hot, humid climate). Salt spray resistance as per IEC 68-2-11.

**Poles**

The 4-pole version is an efficient solution to ground fault problems created by incorrectly grounded standby generators and incorrect transfer switching systems. By isolating the neutral of multiple sources coupled together, 4-pole circuit breakers prevent ground faults from returning to the source via unintended paths. Where unintended paths exist, ground fault sensing can become inaccurate or create nuisance tripping.

Ampere Rating (A)	3-Pole	4-Pole
800	MP-MC	MP-MC
1200	MP	MP
1600	MP-MC	MP-MC
2000	MP-MC	MP-MC
2500	MP	MP
3000	MP	MP
3200	MC	
4000	MP-MC	MP (1)
5000	MP-MC	MP (1)
6300	MP (1)	

(1) Not UL Listed.



## Ratings

Type	Ampere Rating (A)	Sensor Ratings (A)
MP/MC08	800	250–400–600–800
MP12	1200	800–1200
MP/MC16	1600	1200–1600
MP/MC20	2000	1600–2000
MP25	2500	2000–2500
MP30	3000	2500–3000
MC32	3200	2500–3200
MP/MC40	4000	2500–3000–4000
MP/MC50	5000	4000–5000
MP63	6300	5000–6300

## Interrupting Ratings

### UL489/NEMA AB1

Type	Rating (A)	480 Vac	600 Vac	Short-time
<b>Standard Interrupting Rating</b>				
MP08 H1	800	65 kA	65 kA	50 kA
MP12 H1	1200	65 kA	65 kA	50 kA
MP16 H1	1600	65 kA	65 kA	50 kA
MP20 H1	2000	75 kA	75 kA	75 kA
MP25 H1	2500	75 kA	75 kA	75 kA
MP30 H1	3000	75 kA	75 kA	75 kA
MP40 H1	4000	100 kA	100 kA	100 kA
MP50 H1	5000	100 kA	100 kA	100 kA
MP63 H1	6300 (1)	100 kA	100 kA	100 kA
<b>High Interrupting Rating</b>				
MP08 H2	800	100 kA	65 kA	50 kA
MP12 H2	1200	100 kA	65 kA	50 kA
MP16 H2	1600	100 kA	65 kA	50 kA
MP20 H2	2000	100 kA	75 kA	75 kA
MP25 H2	2500	100 kA	75 kA	75 kA
MP30 H2	3000	100 kA	75 kA	75 kA
MP40 H2	4000	125 kA	100 kA	100 kA
MP50 H2	5000	125 kA	100 kA	100 kA
MP63 H2	6300 (1)	150 kA	100 kA	100 kA

(1) Not UL Listed.

### UL1066/ANSI C37–13/NEMA SG3

Type	Rating (A)	508 V	635 V	Short-time
<b>Special Interrupting Rating</b>				
MC08 N1	800	50 kA	50 kA	42 kA
MC16 N1	1600	50 kA	50 kA	50 kA
<b>Standard Interrupting Rating</b>				
MC08 H1	800	65 kA	65 kA	50 kA
MC16 H1	1600	65 kA	65 kA	50 kA
MC20 H1	2000	65 kA	65 kA	65 kA
MC32 H1	3200	65 kA	65 kA	65 kA
MC40 H1	4000	100 kA	100 kA	100 kA
MC50 H1	5000	100 kA	100 kA	100 kA



## Drawout Circuit Breaker Design

- The drawout assembly mechanism allows the circuit breaker to be racked in four positions (connected, test, disconnected and withdrawn).
- The closing and opening push buttons, the racking handle and racking mechanism are accessible through the front door cutout. Therefore the circuit breaker can be disconnected without opening the door and accessing live parts. Safety shutters can be provided as an option for protection from live parts when the circuit breaker is removed.

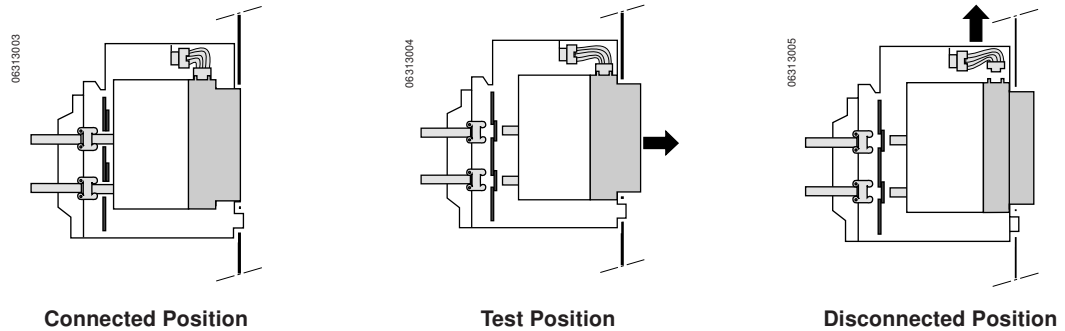

## True Two-step Stored Energy Mechanism

The closing time is less than five cycles. The circuit breaker is operated via a stored-energy mechanism which can be manually or motor charged. Closing and opening operations can be initiated either from the local push buttons on the circuit breaker front face or by remote control. O–C–O cycle is possible without recharging.

## Designed for No Maintenance...

The circuit breaker has fewer parts (by a factor of at least five) than conventional circuit breakers while performing the same functions. This leads to greatly enhanced reliability and reduction in maintenance. Under normal operating conditions, according to standards and controlled by tests, the circuit breaker does not require maintenance.

## ...But Exceeds Standards with an Easy and Reduced Maintenance

It is easy to remove the arc chutes and visually inspect the contacts and wear indicator. The operation counter (spring-charging motor option) can also indicate when inspections and possible maintenance should be done. After operating conditions exceeding those given by standards, it is possible to extend the circuit breaker life by:

- Replacement of arc chutes and spring charging motor by the user.
- Replacement of main contacts by an after sale service team.

*Note: See pages 62–63 for additional information.*

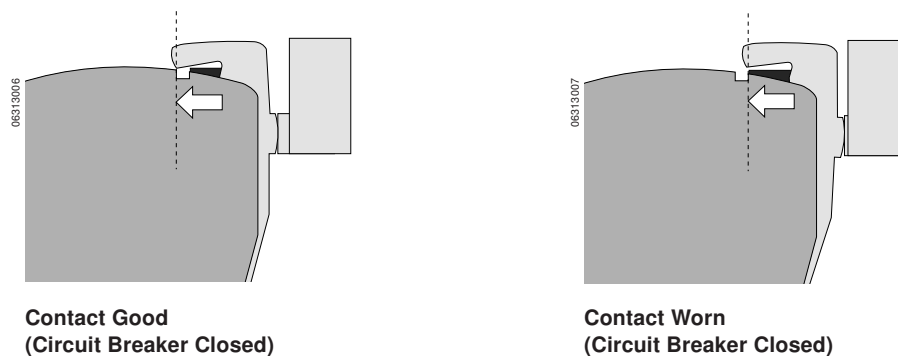

## Advantages

### Single Design up to 6300 A

All frame sizes have been designed with the same technology featuring identical depth and door cutouts, and common control units and accessories.

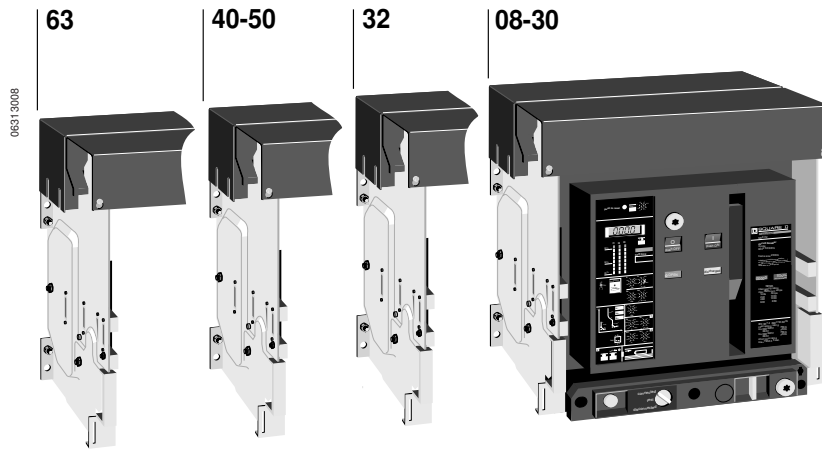

### Field-installable Accessories

- As the installation develops and changes, the circuit breaker can develop and change with it. Most accessories are field-installable, without losing the UL Listing mark, without any adjustment and with only the aid of a screwdriver.
- The uniform design of the circuit breaker line allows these accessories to be common for the whole line.

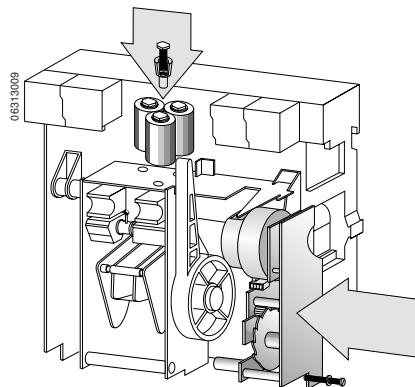

### Front Connection of Secondary Circuits

All accessory terminals are located on a connecting block which is accessible from the front even with the circuit breaker in the test or disconnected position. This is particularly useful for field inspection and modification.



### Disconnecting through Door

The racking handle and racking mechanism are accessible through the front door cutout. Disconnecting the circuit breaker will therefore be possible without opening the door and giving access to live parts.

### Isolation Function by Positive Indication of Contact Status

The mechanical indicator is truly representative of the status of all three main contacts.

### Segregated Compartment

Once the front cover has been removed to provide access to the auxiliary compartment, the main contacts remain fully isolated. Furthermore, interphase partitioning allows full insulation between each pole even if the front cover has been removed.

### Reinforced Insulation

Two insulation barriers separate the front of the circuit breaker from main circuits.

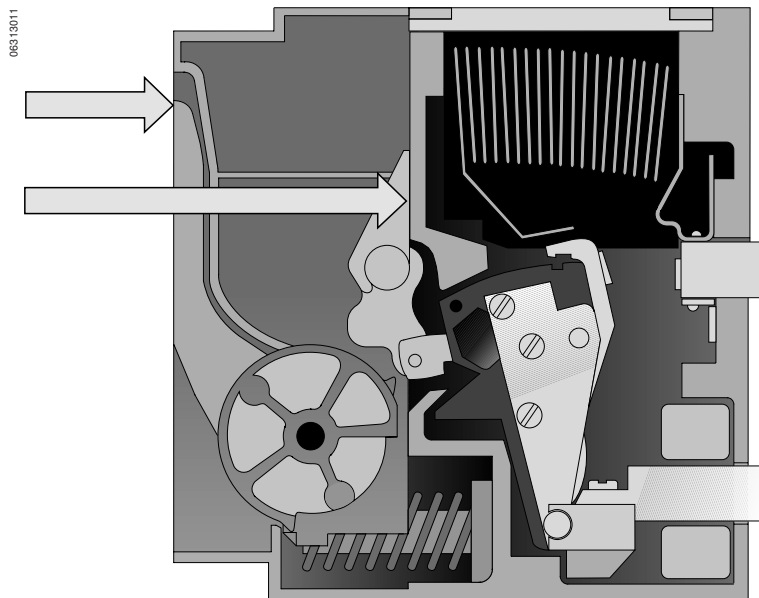

## Description

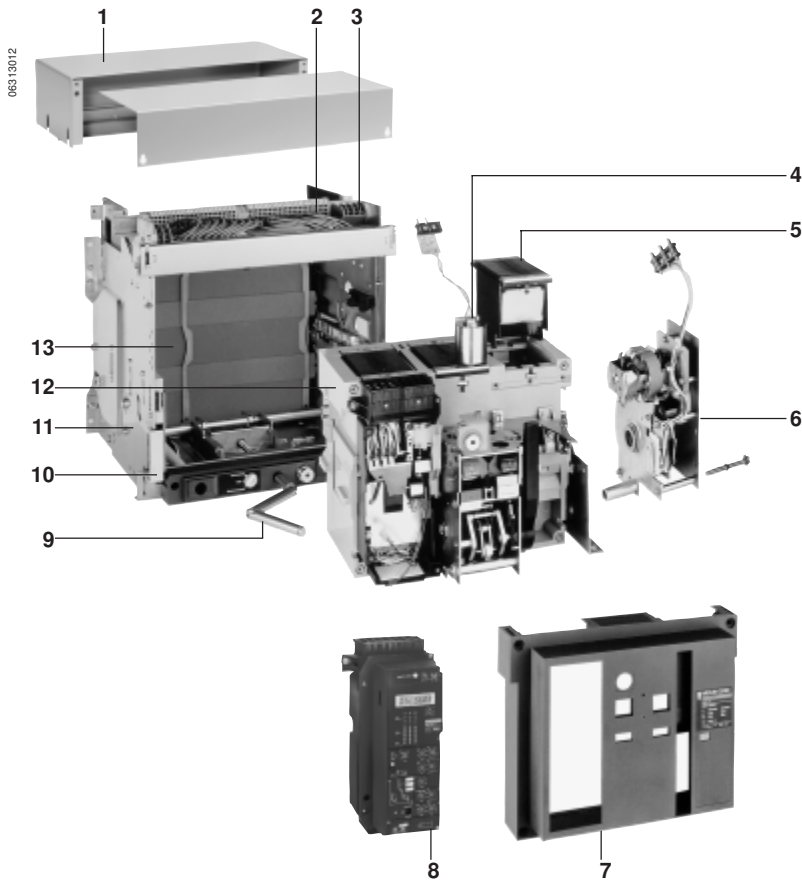

## Description

1. Arc chamber and terminal covers
2. Accessories and control unit front connecting block
3. Position carriage switches
4. Opening coils
5. Arc chute
6. Spring charging motor
7. Front cover
8. Control unit
9. Racking crank
10. Pull-out handgrip
11. Retractable rails
12. Handling handgrip
13. Safety shutters

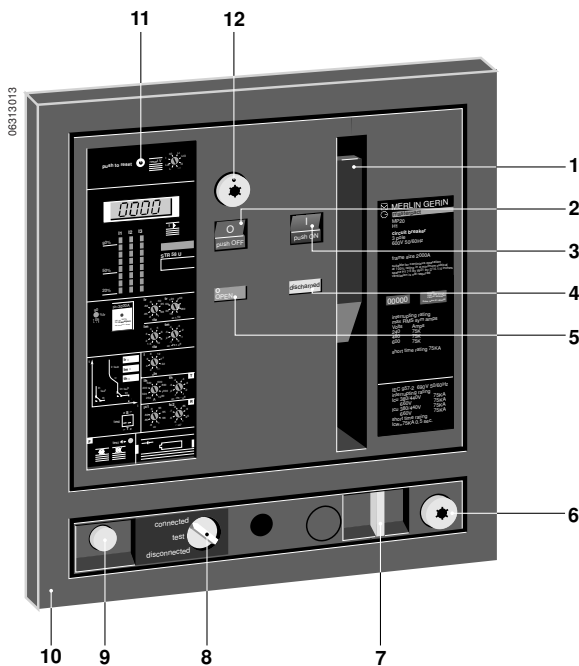

## Front View

1. Charging handle
2. Manual opening push button
3. Manual closing push button
4. Stored energy mechanism status indicator (charged or discharged)
5. Main contact position indicator (open or closed)
6. Disconnected position locking (key interlock)
7. Disconnected position padlocking
8. Drawout position indicator showing that the circuit breaker is in the connected, test or disconnected position
9. Racking crank storage
10. Door escutcheon
11. Fault indicator and reset button
12. Open position locking (key interlock)



06313014



The circuit breaker can be equipped with a microprocessor-based, electronic control unit which provides all the traditional protection of the universal power circuit breaker (long-time, short-time, instantaneous and ground-fault) plus other built-in functions:

- RMS sensing (standard)
- Alarm switch (standard)
- Overcurrent trip switch (standard)
- Interchangeable rating plugs (on STR28DP, STR38SP and STR58UP)
- Thermal memory and I<sup>2</sup>t ramp (standard on STR 38-58 control unit)
- Defeatable instantaneous (standard on STR 38-58 control unit)
- Zone-selective interlocking for ground-fault and short-time (option)
- Current and load meter (option)
- Load-monitoring outputs (option)
- Fault indicators (option)
- Communication ability (option)

Control Units		STR 18M	STR 28D	STR 38S	STR 58U
<b>Basic Features</b>					
Long-time (1)	Setting		Adjustable	Adjustable	Adjustable
	Delay		Fixed	Fixed	Adjustable
Short-time	Pickup			Adjustable	Adjustable
	Delay			Adjustable	Adjustable
Instantaneous		Adjustable	Adjustable	Fixed (2)	Adjustable (2)
Test Receptacle			Standard	Standard	Standard
<b>Additional Features (Options)</b>					
Ground-fault Protection (3)				■	■
Built-in Ammeter			■	■	■
Fault Indicators				■	■
Segregated Alarm Switch					■
Zone-selective Interlocking					■
Load Monitoring					■
Communication Outputs					■

(1) Long-time pickup at 1.1 current setting.

(2) Defeatable on N1 and H1 types.

(3) Two types: residual sensing (T) or residual source ground return (W).



# Control Units

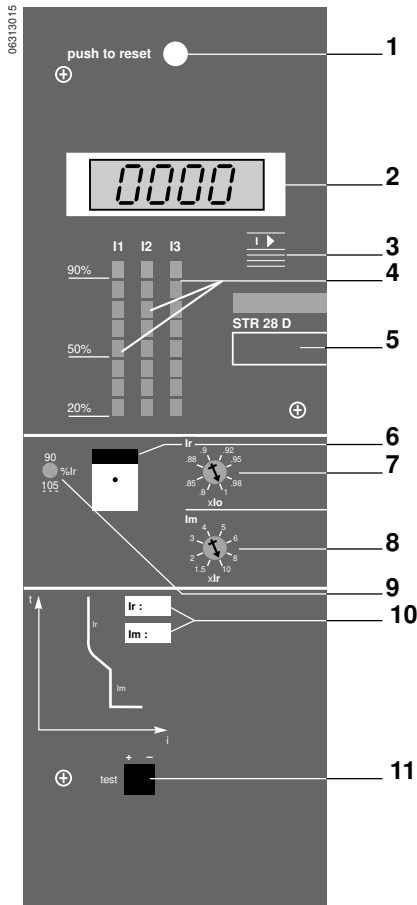

## STR 28D Control Unit for General Application

1. Mechanical pop-out type fault indicator and reset button:
  - Indicates that a fault trip has occurred
  - Prevents closing of the circuit breaker after fault until reset
2. Ammeter (LCD digital display)
3. Ammeter selector used to read:
  - Phase currents (1, 2, 3, N)
  - Or the phase with the highest load current (max.)
4. Load indication (bar graph in % of current setting)
5. Sensor rating
6. Rating plug (on STR 28DP)
7. Long-time current setting
8. Instantaneous pickup
9. Local and remote pre-trip alarm:
  - LED on at 90% of current setting
  - LED flashing on overload (1)
  - Remote indication by static contact
10. Available spaces for setting identification
11. Test receptacle

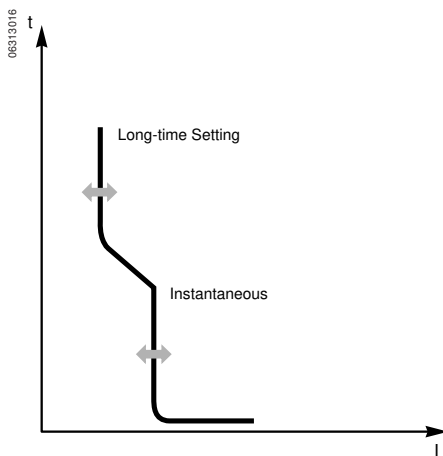

Overcurrent Protection—RMS Sensing		
Long-time	Current Setting	STR 28DP: 0.8 to 1 x Rating Plug (Pickup at 1.1 x Setting) STR 28D: 0.4 to 1 x Current Sensor (Pickup at 1.1 x Setting)
	Max. Delay	Fixed: 7.5 sec. at 6 x Current Setting
Rating Plug	Current Sensor	Plug Rating
	250 A	250–200–150–125 A
	400 A	400–300–250–200 A
	600 A	600–500–400–300 A
	800 A	800–600–500–400 A
	1200 A	1200–1000–800–600 A
	1600 A	1600–1200–1000–800 A
	2000 A	2000–1600–1200–1000 A
	2500 A	2500–2000–1600–1200 A
	3000 A	3000–2500–2000–1600 A
Instantaneous	Pickup	1.5 to 10 x Current Setting
	<b>Built-in Ammeter (Optional)</b>	
Option I	Values Displayed	Phase 1, 2, 3, Max., Neutral Current
	Accuracy	±1.5 % (2)
	Bar Graph Indication	Phase 1, 2, 3—10% Steps
	Control Power	Not Required (3)
<b>Fault or Alarm Indicators</b>		
Not Discriminated	Local	Pop-out Type Indicator and LED Pre-trip Alarm
	Remote	Overcurrent Trip and Pre-trip Alarm Switches (see pp. 14–15)

(1) According to time-current curves: between 105% and 120% of current setting.

(2) Total accuracy including current sensors: ±4.5%.

(3) Control power not required for loads greater than 20% of current sensor. Required for load less than 20% of current sensors if maximum demand memory requested (see diagram on p. 43).

Note: *Io*: Rating plug  
*In*: Sensor rating  
*Ir*: Long-time pickup  
*tr*: Long-time delay  
*Im*: Short-time pickup

*tm*: Short-time delay  
*I*: Instantaneous pickup  
*Ih*: Ground-fault pickup  
*th*: Ground-fault delay



0631 3017

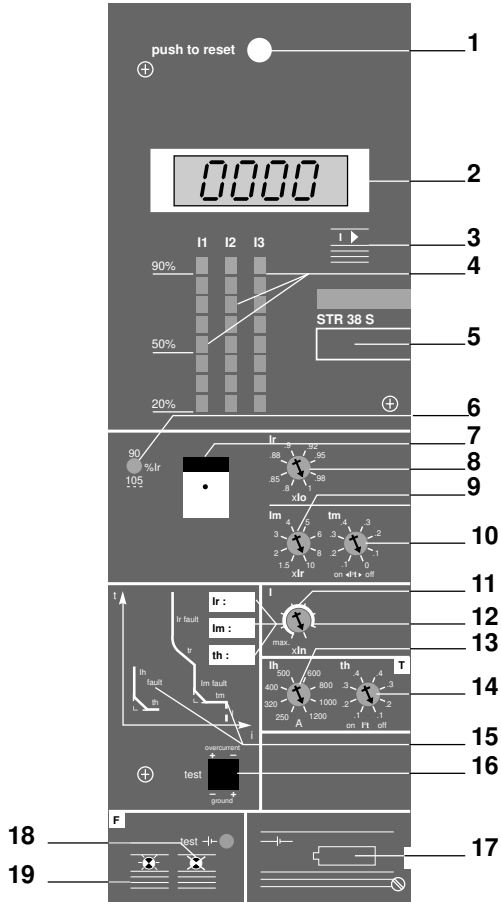

**STR 38S Control Unit for Selective Application**

1. Mechanical pop-out type fault indicator and reset button:
  - Indicates that a fault trip has occurred
  - Prevents closure of the circuit breaker after fault until reset
2. Ammeter (LCD digital display)
3. Ammeter selector used to read:
  - Phase currents (1, 2, 3, N, ground)
  - Or the phase with the highest load current (max.)
4. Load indication (bar graph in % of current setting)
5. Sensor rating
6. Local and remote pre-trip alarm:
  - LED on at 90% of current setting
  - LED flashing on overload (1)
  - Remote indication by static contact
7. Rating plug (on STR 38SP)
8. Long-time current setting
9. Short-time pickup
10. Short-time delay
11. Instantaneous ON/OFF selector
12. Available space for setting identification
13. Ground-fault (option T) pickup
14. Ground-fault (option T) time delay
15. Local (option F) fault indicators consisting of built-in light emitting diodes; fault indicators differentiate the three causes of tripping: overload, short circuit and ground fault, if any
16. Test receptacle
17. Fault indicator saving battery (option PIL)
18. Fault indicator reset or battery test button
19. Fault indicator reactivating button (option PIL) (2)

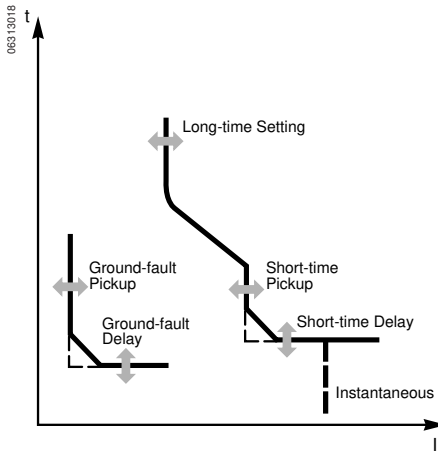

Overcurrent Protection—RMS sensing		
Long-time	Current Setting	STR 38SP: 0.8 to 1 x Rating Plug (Pickup at 1.1 x Setting) STR 38S: 0.4 to 1 x Current Sensor (Pickup at 1.1 x Setting)
	Delay	Fixed: 7.5 sec. at 6 x Current Setting
		Thermal Memory as Standard
Rating Plug		4 to 6 Rating Plugs Available Per Sensor Rating: See STR 28D Control Unit, p. 8
Short-time	Pickup	1.5 to 10 x Current Setting
	Delay Bands	0–0.1–0.2–0.3–0.4 with I <sup>2</sup> t OFF 0.1–0.2–0.3 with I <sup>2</sup> t ON
Instantaneous	Pickup	High-set Fixed Type (3)—Defeatable on N1 and H1 Types
Ground-fault Protection (Option T or W) (4)		
Pickup		0.1 x Current Sensor to 1200 A (5)
Delay Band		0.1–0.2–0.3–0.4 with I <sup>2</sup> t Ramp ON/OFF Switch
Fault Indicators (Option F)		
Not Discriminated	Local	Mechanical Pop-out Type Indicator and LED Pre-trip Alarm
	Remote	Overcurrent Trip and Pre-trip Alarm Switches (see pp. 14–15)
Discriminated	Local	With Option F (see p. 14)
Built-in Ammeter (Option I)		
Values Display		Phase 1, 2, 3, Max., Neutral and Ground Current
Accuracy		±1.5% (6)
Bar Graph Indication Phases 1, 2, 3—10% steps		
Control Power		Not Required (7)

(1) According to time current curves: 105% to 120% of current setting.  
 (2) With PIL option, fault indicator lights (15) will light up only when this button is pushed in.  
 (3) See values on pp. 38–40.  
 (4) Residual scheme (T). The maximum ground-fault pickup meets 1999 National Electrical Code paragraph 230-95 (a) (not exceeding 1200 A). Source Ground Return scheme (W) on request.  
 (5) 0.1 minimum pickup requires 24 Vdc external power.  
 (6) Total accuracy including current sensors: ±4.5%.  
 (7) Control power not required for loads greater than 20% of current sensor. Required for loads less than 20% of current sensor if maximum demand memory requested (see diagram, p. 43).

# Control Units

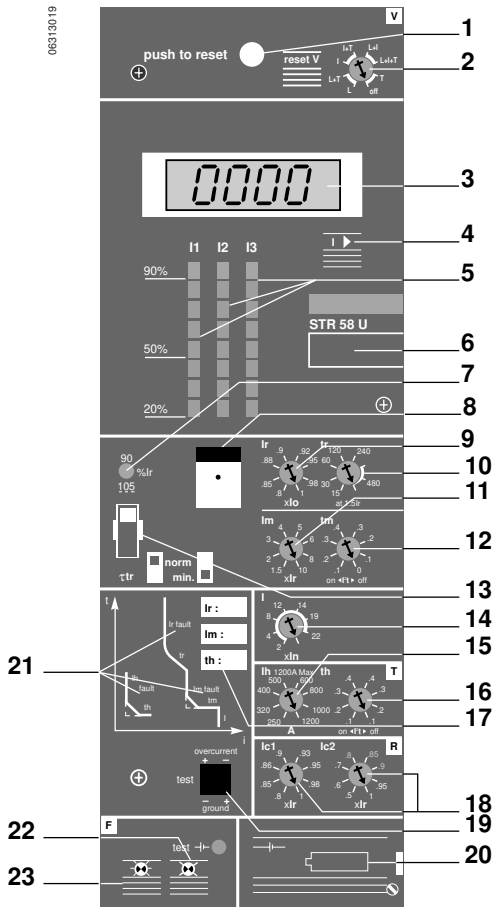

## STR 58U Control Unit for Universal Application

1. Mechanical pop-out type fault indicator and reset button:
  - Indicates that a fault trip has occurred
  - Prevents closure of the circuit breaker after fault until reset
2. Switch selector for the type of fault to be remotely indicated and reset flat push button (see option FV, p. 15)
3. Ammeter (LCD digital display)
4. Ammeter selector used to read:
  - Phase currents (1, 2, 3, N, ground)
  - Or the phase with the highest load current (max.)
5. Load indication (bar graph in % of current setting)
6. Sensor rating
7. Local and remote pre-trip alarm:
  - LED on at 90% of current setting
  - LED flashing on overload (according to time current curves: 105% to 120% of current setting)
  - Remote indication by static contact
8. Rating plug (on STR 58UP)
9. Long-time current setting
10. Long-time delay setting
11. Short-time pickup
12. Short-time delay
13. Thermal memory min./max. selector
14. Instantaneous pickup
15. Ground-fault (option T or W) pickup
16. Ground-fault (option T or W) time delay
17. Available space for setting identification
18. Load monitoring (option R) pickups (see p. 16)
19. Test receptacle
20. Fault indicator saving battery (option PIL)
21. Local (option F) fault indicators consist of built-in light emitting diodes which differentiate the three causes of tripping: overload, short circuit and ground fault, if any
22. Fault indicator reset or battery test button
23. Fault indicator reactivating button (with PIL option, fault-indicator lights (21) will only light up when this button is pushed in)



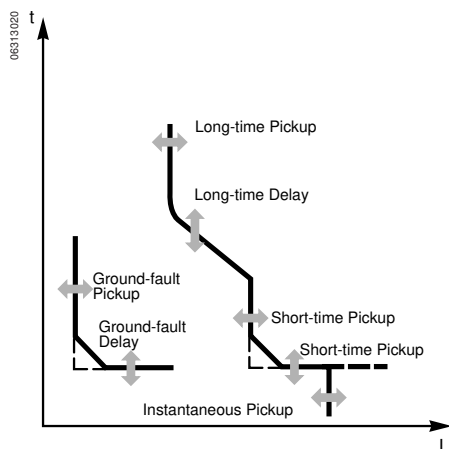

Overcurrent Protection—RMS Sensing		
<b>Long-time</b>	Current Setting	STR 58UP: 0.8 to 1 x Rating Plug (Pickup at 1.1 x Setting) STR 58: 0.4 to 1 x Current Sensor (Pickup at 1.1 x Setting)
	Delay Bands	0.94–1.88–3.75–7.50–15–30s at 6 x Current Setting
	Thermal Memory as Standard with Min./Max. Selector	
<b>Rating Plug</b>	Current Sensor	Plug Rating
	250 A	250–200–150–125 A
	400 A	400–300–250–200 A
	600 A	600–500–400–300 A
	800 A	800–600–500–400 A
	1200 A	1200–1000–800–600 A
	1600 A	1600–1200–1000–800 A
	2000 A	2000–1600–1200–1000 A
	2500 A	2500–2000–1600–1200 A
	3000 A	3000–2500–2000–1600 A
	3200 A	3200–3000–2500–2000–1600 A
4000 A	4000–3200–3000–2500–2000 A	
5000 A	5000–4000–3200–3000–2500 A	
6300 A	6300–6000–5000–4000–3200–3000 A	
<b>Short-time</b>	Pickup	1.5 to 10 x Current Setting
	Delay bands	0–0.1–0.2–0.3–0.4 with I <sup>2</sup> t OFF 0.1–0.2–0.3 with I <sup>2</sup> t ON
	Zone-selective Interlocking with Option Z (see p. 13)	
<b>Instantaneous</b>	Pickup	Adjustable from 2 to Max. Value (1); Defeatable on N1 and H1 Types
Ground-fault Protection (Option T or W) (2)		
<b>Pickup Delay Band</b>	0.1 x Current Sensor to 1200 A (3)	
	0.1–0.2–0.3–0.4 with I <sup>2</sup> t Ramp ON/OFF Switch	
	Zone-selective Interlocking with Option Z (see p. 13)	
Fault Indicators (Option F)		
<b>Not Discriminated</b>	Local	Mechanical Pop-out Type Indicator and LED Pre-trip Alarm
	Remote	Overcurrent Trip and Pre-trip Alarm Switches (see pp. 14–15)
<b>Discriminated</b>	Local	With Option F (see p. 14)
	Remote	With Option FV (see p. 15)
Built-in Ammeter (Option I)		
	Values Display	Phase 1, 2, 3, Max., Neutral and Ground Current
	Accuracy	±1.5% (4)
	Bar Graph Indication Phase 1, 2, 3—10% Steps	
	Control Power	Not Required (5)
Load Monitoring (Option R)		
<b>Inverse Time Alarm</b>	Pickups	Ic1 = 0.8 to 1 x Current Setting
		Ic2 = 0.5 to 1 x Current Setting
	Time delay	See Curve, p. 41
Outputs for Communication through DIGIPACT® System (Option C)		
<b>Transmitted Values</b>	Entire Settings of the Trip Unit	
	Circuit Breaker Status: Open, Tripped, Closed	
	Alarms: Overload, Type of Fault, Internal Watchdog (6)	
	Ammeter Values: Phase, Neutral, Ground, Max. Currents	

(1) See values on pp. 38–40.

(2) Residual scheme (T). The maximum ground-fault pickup meets 1999 National Electrical Code paragraph 230-95 (a) (not exceeding 1200 A). Source Ground Return scheme (W) on request.

(3) 0.2 minimum pickup only with external power.

(4) Total accuracy including current sensors: ± 4.5%.

(5) Control power not required for loads greater than 20% of current sensors. Required for loads less than 20% of current sensor if maximum demand memory requested (see diagram, p. 43).

(6) Internal watchdog: Control unit internal temperature.



# Control Units

06313182

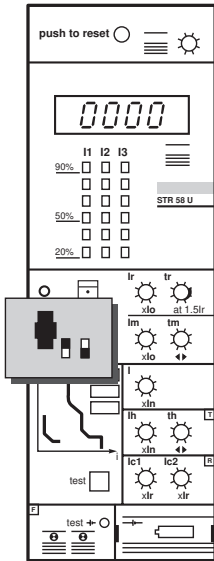

## Thermal Memory

### Purpose

The thermal memory function allows an optimization of cables or bus bar protection in case of low amplitude repetitive faults. Such faults can be due to repetitive motor startings, fluctuating load or subsequent closing after a fault.

Traditional electronic protection has no effect when facing such repetitive faults because the duration of each overload above the pickup setting is too short to achieve effective tripping. Nevertheless, each overload involves a temperature rise in the installation, the cumulative effect of which could lead to overheating of the system.

### Principle

**⚠ DANGER**

**HAZARD OF ELECTRICAL SHOCK, BURN OR EXPLOSION.**

Use "min" position for emergency only when closing on fault is absolutely necessary.

**Failure to observe these precautions will cause death, personal injury or electrical shock.**

The thermal memory function remembers and integrates the thermal heating caused by each pickup setting overrun. Before tripping, the integrated heating value will reduce the associated time delay and, therefore, the reaction of the control unit will be closer to the real heating of the power network system. After tripping, the memory will also reduce the time delay when closing the circuit breaker on fault.

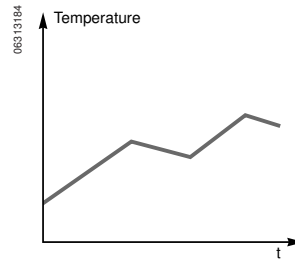
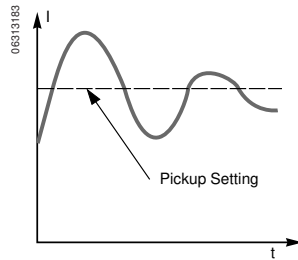

## STR Trip Units

The STR 38S and STR 58U trip units incorporate the thermal memory as standard:

- Before tripping on long-time and ground-fault protection (if provided)
- After tripping on long-time protection only, adjustable min./max. position for the STR 58U trip unit is standard

The control unit measures the internal temperature rise of the circuit breaker by thermal resistors. The cooling time constant of the memory is not fixed, but depends on the over-temperature condition.

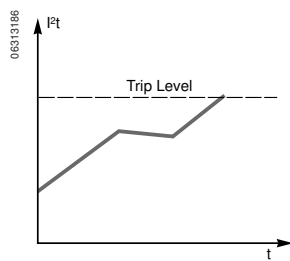

**STR Trip Unit with Thermal Memory**

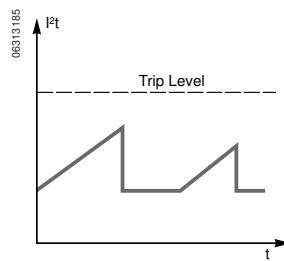

**STR Trip Unit without Thermal Memory**



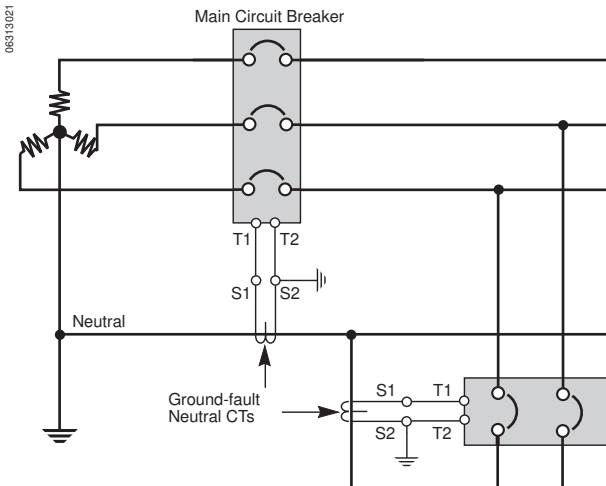

Note: #18 to #14 AWG cables, max. length 90 ft./30m.

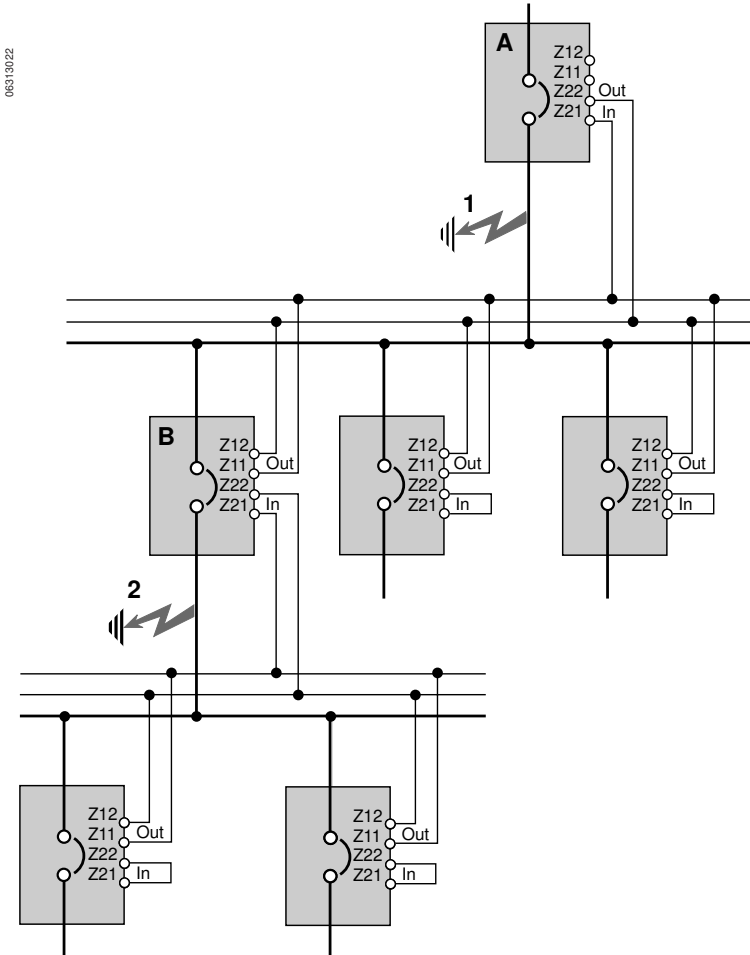

## Neutral Sensor

Ground-fault protection may be applied on 3Ø4W or 3Ø3W circuits. On 3Ø4W circuits an external neutral sensor must be used. This neutral current sensor must have the same ampere rating as the circuit breaker sensor.

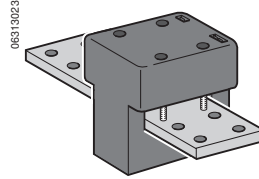

## Zone-selective Interlocking (ZSI)

Option Z on the STR58U control unit provides selective interlocking on short time or ground fault. A pilot wire links several trip units in the distribution network, as shown in the opposite figure. In the event of a fault, the trip unit will respond to the preset delay only if receiving a signal from the downstream unit. If not receiving a signal, the tripping will be instantaneous. Therefore, the fault is cleared instantaneously by the nearest circuit breaker: the thermal stresses ( $I^2t$ ) in the network are minimized, without any effect on the correct time-delay coordination in the installation.

### Fault 1

Circuit breaker A will clear the fault instantaneously, regardless of its time-delay setting.

### Fault 2

Circuit breaker B will inform upstream circuit breaker A that it is clearing the fault and will prevent it from tripping instantaneously. Circuit breaker A will trip at the end of its time delay setting if the fault is not cleared during this time.

### Note:

- Drawout circuit breaker terminals are delivered with "in" terminals jumpered. Remove the jumper when interlocking with a downstream circuit breaker.
- The MASTERPACT circuit breaker may also be interlocked with COMPACT® NS and CK type molded case circuit breakers with ZSI option.
- Do not ground ZSI wiring.

Cable Size	#18-#14 AWG/1.5mm <sup>2</sup>
Max. Length	90 ft./30 m
Wiring	Twisted in Pairs One Turn per 4 in./10 cm
No. of Circuit Breakers	Upstream: 2 Downstream: No Limit



# Control Units

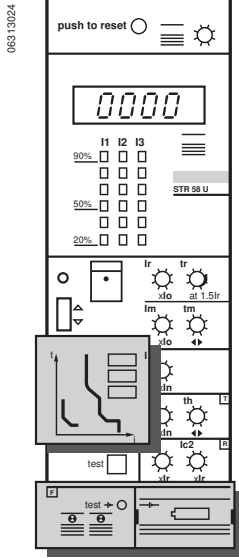

## Fault Indicator (F)

In addition to the mechanical fault indicator, this indicator differentiates the three causes of tripping: overload, short circuit or ground fault, if any. Three light-emitting diodes indicate separately long-time, short-time/ instantaneous and ground-fault trip. A flat push button allows resetting of the indicator after tripping. A separate power supply is required to maintain the indication after tripping of the circuit breaker. Two different possibilities are offered:

- Connecting a reliable 24 Vdc control voltage on F1-F2. Auxiliary power module (AD) is used for other voltages. When the control source is considered as unreliable, a battery pack (BAT) is to be added to an AD power module.
- From a built-in battery module. When no external control source is available, a built-in battery module may be ordered (option PIL). This module integrates battery testing and indicator reactivating buttons.

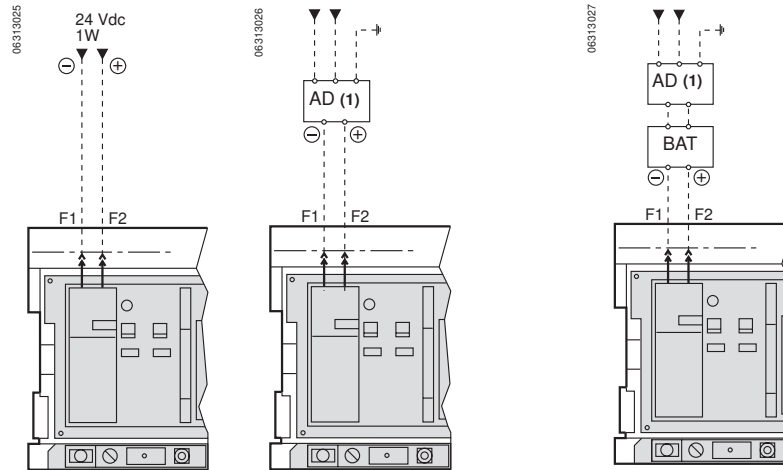

(1) AC: 120 V, 60 Hz  
DC: 24–48–125 Vdc

**Configuration with Reliable Control Voltage**

**Configuration with Interruptible Control Voltage**

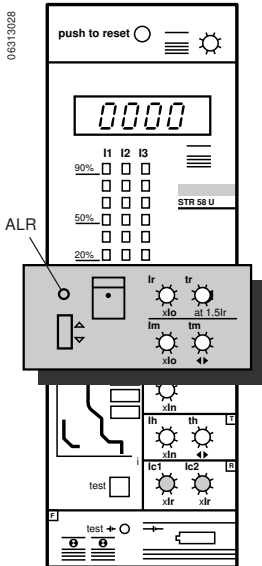

## Alarm Indicator Pre-trip Alarm Switch (ALR)

Delivered as standard with control unit. The alarm indicator is a fixed, front face light-emitting diode which operates as follows:

- Fixed when the current exceeds 90% of the current setting.
- Flashing on overload: according to time-current curves, 105% to 120% of current setting.

The pre-trip alarm switch is a static contact which closes when in the overload zone, up to the tripping of the circuit breaker. This contact can be used for ultimate load shedding, alarm before tripping, etc.

Output Characteristics	0.1 A/240 Vac (Optical Triac)
Power Supply	Not Required





# Control Units

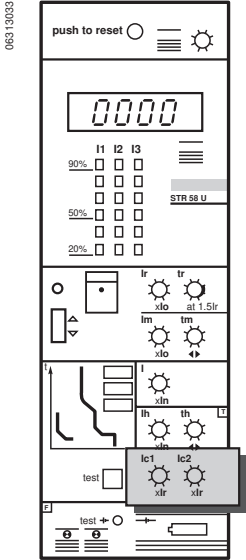

## Load monitoring (R)

Option R provides two independent static contacts which operate when the current exceeds adjustable pickup limits:

- When the current exceeds the limit  $I_{c1}$  (or  $I_{c2}$ ), the contact C-R1 (or C-R2) closes following an inverse time characteristic **A**.
- When the current drops below the limit  $I_{c1}$  (or  $I_{c2}$ ), the contact C-R1 (or C-R2) opens with constant time delay (10 seconds) **B**.

These contacts can be used for load shedding, alarms, indications, etc.

Voltage	240 Vac max.
Outputs	0.1 A triac

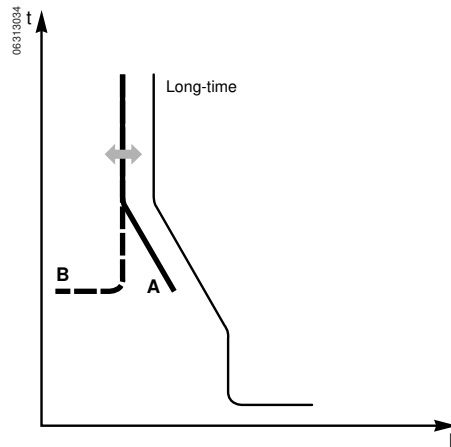

## Test Kits

Every control unit is equipped with a test receptacle that can be used with a test kit. Tests performed by test kits are only functional tests designed to electrically test the operating integrity of the control unit, the flux transfer device and the mechanical operation of the circuit breaker. Tests are not designed to calibrate the circuit breaker. Calibration can only be done at the factory.

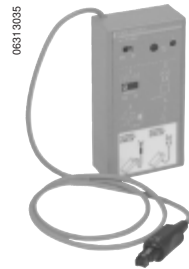

Mini Test Kit



Calibration Test Kit



## Communication

MASTERPACT circuit breakers can be easily connected to a supervising personal computer using the DIGIPACT® system. The following four functions can thus be provided:

■ **Indication:**

- Status of the circuit breaker (on, off or tripped; connected or disconnected)
- Causes of tripping (overload, short circuit or ground fault)

■ **Monitoring:**

- Operation of circuit breaker (open, closed or reset)
- Resetting a molded case circuit breaker (COMPACT NS and CK)

■ **Management:**

- Control unit settings
- Pre-trip alarm
- Load monitoring status
- Control unit internal temperature alarm
- Number of operation cycles performed by the circuit breaker

■ **Metering:**

- RMS value of the current in three phases

Communication with Supervision,  
Personal Computer

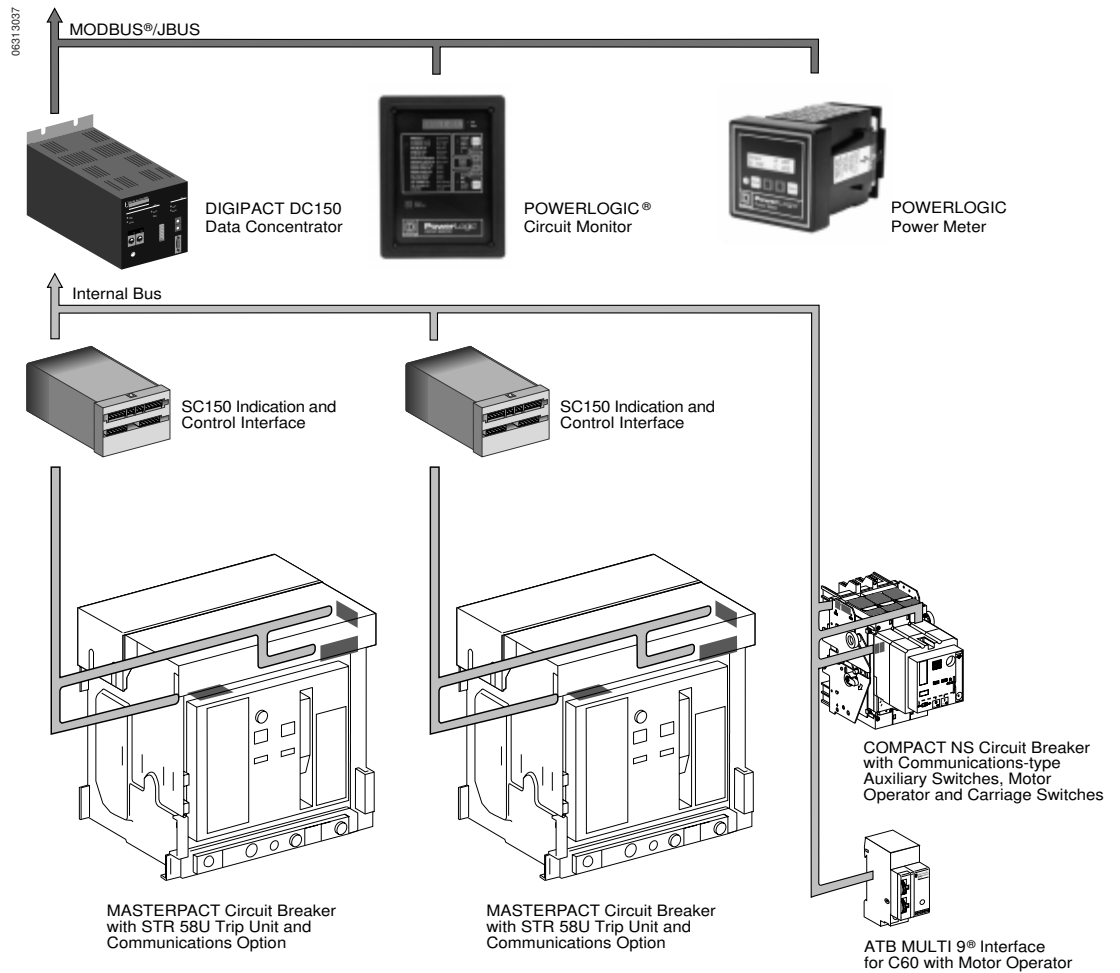

# Control Units



## SC150 Indication and Control Interface

### Function

The SC150 indication and control interface is used to:

- Transmit to the DC150 data concentrator:
  - Status information (on, off, tripped, tripped due to electrical fault, tripped due to ground fault) for COMPACT CK and MASTERPACT circuit breakers or any other power circuit actuator
  - The connected or disconnected status of withdrawable COMPACT CK and MASTERPACT circuit breakers
  - The status of any external contact
- Receive commands transmitted by a personal computer or programmable logic controller (PLC) via the DC150 data concentrator (on, off and reset of the COMPACT CK and MASTERPACT circuit breakers or any other power circuit actuator)
- Receive the information transmitted by the communications option on electronic control units (STR43, STR53, STR55 and STR58) installed in COMPACT NS, COMPACT CK and MASTERPACT circuit breakers:
  - Trip-unit settings
  - The RMS value of the current in the three phases and the neutral
  - Current overloads
  - The causes of tripping (overloads, short circuits or ground fault)
- Count the number of cycles carried out by the device

The SC150 interface is connected to:

- The DC150 data connector
- The auxiliary switches (OF, SD, SDE, SDV, CE, CD) on the circuit breaker with which the interface is associated
- The motor operator for execution of the on, off and reset commands
- The communications outputs of the STR43, STR53, STR55 and STR58 control units installed in COMPACT NS, COMPACT CK and MASTERPACT circuit breakers

A non-assigned digital input is available for other use. The SC150 interface is associated with a single circuit breaker.

**Important:** The SC150 interface is used with COMPACT NS circuit breakers to:

- Remote to the user the information supplied by the communications option on STR43 and STR53 control units
- Actuate non-communicating motor operators
- Count the number of cycles carried out by the circuit breaker

*Note: When associated with the SC150 interface, COMPACT NS circuit breakers are equipped with standard auxiliary switches and motor operators. The SC150 indication and control interface is not required with COMPACT NS circuit breakers equipped with communication-type auxiliary switches or a communication-type motor operator.*

### Information or Function Managed by the SC150 Indication and Control Interface

Information Transmitted or Function Carried Out	Devices Associated with the SC150 Interface
<b>Display Device Status:</b> <ul style="list-style-type: none"> <li>■ On, Off</li> <li>■ Tripped</li> <li>■ Tripped Due to Electrical Fault</li> <li>■ Tripped Due to Ground Fault</li> <li>■ Connected or Disconnected Position</li> </ul>	<b>Circuit Breaker or Other Power-circuit Actuator</b> <ul style="list-style-type: none"> <li>+ Standard OF Auxiliary Switches</li> <li>+ Standard SD Auxiliary Switches (COMPACT Circuit Breakers)</li> <li>+ Standard SDE Auxiliary Switches</li> <li>+ SDV Auxiliary Switches (COMPACT NS) or Output Contact of a Ground-fault Relay</li> <li>+ Standard CE and CD Auxiliary Switches</li> </ul>
<b>Remotely Control a Device (On, Off or Reset)</b>	COMPACT or MASTERPACT Circuit Breaker Equipped with Standard Motor Operator
<b>Count the Number of Operating Cycles</b>	As Above
<b>Display the Cause of Tripping and the Trip Unit Settings (Settings and Time Delays)</b>	COMPACT or MASTERPACT Circuit Breaker Equipped with STR43, STR53, STR55 or STR58 Electronic Trip Unit with Communications Option (COM)
<b>Trip an Alarm for Long-time Fault</b>	As Above
<b>Display the Value of the Current for Each Phase</b>	As Above
<b>Display Internal Temperature of Switchboard</b>	PT100 Probe -4 to 212°F (-20 to 100°C)



## SC150 Indication and Control Interface (continued)

## Technical Data

Digital Inputs (24 V, Self-powered by the SC150 Interface)		
O Auxiliary Switch		One Input
F Auxiliary Switch		One Input
SD Auxiliary Switch (Tripping)		One Input
SDE Auxiliary Switch (Tripping Due to Electrical Fault)		One Input
CE Auxiliary Switch		One Input
CD Auxiliary Switch		One Input
SDV Auxiliary Switch (Tripping Due to Ground Fault)		One Input
Other Uses		One Unassigned Input
Electrical Characteristics		
Voltage (Supplied by SC150)		24 Vdc
Current (Supplied by SC150)		120 mA dc
Resistance in On-state		< 30 mΩ
Resistance in Off-state		> 10000 MΩ
Control Outputs		
Opening		One N.O. and N.C. Control Terminal
Closing		One N.O. Control Terminal
Reset		One N.O. Control Terminal
		<i>Note: The opening, closing and reset control signals delivered by the SC150 interface are of the impulse type. The pulse duration is one second for the closing signal and two seconds for the opening and reset signals.</i>
Voltage		100–440 Vac/24–250 Vdc
Interrupting Rating	AC	2500 VA
	DC	300 W Continuous/500 W for Two Seconds
Utilization Category		AC15/DC13 as Defined by IEC 947-5
Operating Temperature Range		–13 to 158°F (–25 to 70°C)
Storage Temperature Range		–67 to 185°F (–55°C to 85°C)
Damp Heat Not in Operation (IEC 68-2-30)		6 cycles 77°F (25°C)/131°F (55°C)/RH 95%
Damp Heat in Operation (IEC 68-2-56)		2 days 86°F (30°C)/RH 93%
Salt Mist (IEC 68-2-52)		Kb Test, Severity Level 2
Electromagnetic Compatibility	Electrostatic Discharges (IEC 1000-4-2)	Level 3
	Radiated Susceptibility (IEC 1000-4-3)	Level 3
	Low-energy Conducted Susceptibility (IEC 1000-4-4)	Level 4
	High-energy Conducted Susceptibility (IEC 1000-4-5)	Level 4
	Conducted and Radiated Emissions (EN 50081-1)	Class A
Dimensions		2 x 4 x 6.5 in. (50 x 105 x 165 mm)
Weight		2.5 lb. (1 kg)
Degree of Protection (as Per IEC 529)	Front Face	IP30
	Other Faces	IP30
	Connections	IP20
Vibrations (Lloyd's 1996)	Fc Test	5–13.2 Hz: .04 in. (1 mm)
		13.2–100 Hz: .03 oz. (0.7 g)
Wiring Diagram		
See p. 44		
Dimensions		
See pp. 61		



# Control Units

06313039



## DC150 Data Concentrator

### Function

The DC150 data concentrator is used to:

- Centralize all the information supplied by the various communicating devices:
  - Auxiliary switches and motor operator
  - SC150 indication and control interface
- Make information available to a personal computer or programmable logic controller (PLC) via the MODBUS/JBUS protocol
- Log status changes and tripping of the communicating circuit breakers in order to provide the user with a list of time-stamped events
- Supply the 24 V and 15 V power required by the communicating devices and the internal bus
- Carry out addressing for the communicating devices

Each DC150 data concentrator can be connected to a maximum of 48 instrumented outgoing or incoming circuits.

### Information or Function Managed by the DC150 Data Concentrator

Information Transmitted or Function Carried Out	Devices Required to Display the Information or Carry Out the Function
<b>Display Device Status:</b>	<b>Circuit Breaker or Other Power-circuit Actuator</b>
<ul style="list-style-type: none"> <li>■ On, Off, Tripped, Tripped Due to Electrical Fault, Connected, Disconnected</li> </ul>	<ul style="list-style-type: none"> <li>□ COMPACT NS Circuit Breaker + Communicating Auxiliary Switches</li> <li>□ COMPACT/MASTERPACT Circuit Breaker + SC150 Indication and Control Interface</li> <li>□ COMPACT NS Circuit Breaker + Communicating Auxiliary Switches</li> <li>□ MULTI 9 Control Device + ATB Interface</li> <li>□ COMPACT NS Circuit Breaker + Vigi or Ground-fault Relay + SC150 Indication and Control Interface</li> </ul>
<ul style="list-style-type: none"> <li>■ Tripped Due to Ground Fault</li> </ul>	<ul style="list-style-type: none"> <li>■ COMPACT NS Circuit Breaker + Communicating Motor Operator</li> <li>■ COMPACT/MASTERPACT Circuit Breaker + SC150 Indication and Control Interface</li> <li>■ MULTI 9 Control Device + ATB Interface</li> </ul>
<b>Remotely Operate a Circuit Breaker</b> (On, Off or Reset)	<ul style="list-style-type: none"> <li>■ COMPACT NS Circuit Breaker + Communicating Motor Operator</li> <li>■ COMPACT/MASTERPACT Circuit Breaker + SC150 Indication and Control Interface</li> <li>■ MULTI 9 Control Device + ATB Interface</li> </ul>
<b>Inhibit Reset Following Tripping Due to Electrical Fault</b>	As Above
<b>Select Operating Mode of Motor Operators (Local or Remote)</b>	As Above + CLS150 Indication and Local Control Module
<b>Measure Currents (Phases and Neutral)</b>	COMPACT/MASTERPACT Circuit Breaker Equipped with Electronic Control Unit Comprising Communications Option + SC150 Indication and Control Interface
<b>Count Number of Operating Cycles</b>	SC150 Indication and Control Interface
<b>Display Causes of Tripping</b>	COMPACT/MASTERPACT Circuit Breaker Equipped with Electronic Control Unit Comprising Communications Option + SC150 Indication and Control Interface
<b>Display Trip Alarm for Long-time Fault</b>	As Above
<b>Display Trip Unit Settings (Thresholds and Time Delay)</b>	As Above

### Accessories

<b>Connection</b>	Cable for Internal Bus	Cat. No. 50779 65 ft. (20 m) or 50780 330 ft. (100 m)
	Junction Block for Internal Bus	Cat. No. 50778
	RS485/RS232 Conversion Unit	Cat. No. 50786
<b>Connection to Personal Computer</b>	An RS232/RS485 converter is required for connection to a personal computer equipped with an RS232 output to the MODBUS/RS485 bus.	

06313040



RS232/RS485 Converter

06313041



Junction Block

06313116

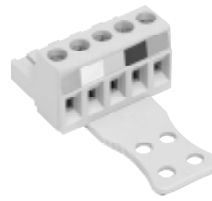

Connector

06313042



Internal Bus Cable



DC150 Data Concentrator (continued)

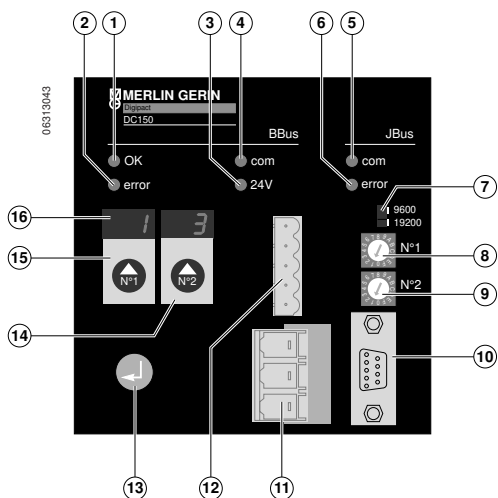

Description

- 1. LED indicating that address is correct
- 2. LED indicating that address is incorrect
- 3. LED indicating presence of 24 V power
- 4. LED indicating communication on internal bus
- 5. LED indicating MODBUS/JBUS communication
- 6. LED indicating MODBUS/JBUS error
- 7. MODBUS/JBUS speed setting
- 8-9. Coding wheels for JBUS address
- 10. JBUS connector
- 11. Power supply connector
- 12. Internal bus connector
- 13. Confirmation button
- 14-15. Keys for DIGIPACT module addresses
- 16. Address display

Technical Data

Electrical Characteristics		
Voltage	110–240 Vac/115–125 Vdc	
Tolerance	+10%–15%	
Operating Temperature Range	–13 to 158°F (–25 to 70°C)	
Storage Temperature Range	–67 to 158°F (–55 to + 70°C)	
Electromagnetic Compatibility	Electrostatic Discharges	Level 3 (IEC 1000-4-2)
	Radiated Susceptibility	Level 3 (IEC 1000-4-3)
	Low-energy Conducted	Level 4 Susceptibility (IEC 1000-4-4)
	High-energy Conducted	Level 4 Susceptibility (IEC 1000-4-5)
	Conducted and Radiated	Class A Emissions (EN 50081-1)
	Protocol	MODBUS/JBUS (Slave)
Speed	9600 or 19200 Baud	
Data Format	Eight Bits, No Parity, One Stop	
Physical Link	RS485 (2-Wire or 4-Wire)	
Implemented MODBUS/JBUS Protocol Functions	Read N Consecutive Bits	Function 1 or 2
	Read N Words	Function 3 or 4
	Write One Bit	Function 5
	Write One Word	Function 6
	Write N Bits	Function 15
	Write N Words	Function 16
Weight	4 lb. (1.5 kg)	
Degree of Protection (as Per IEC 529)	IP30	
	IP20 (Connections)	
Wiring Diagrams		
See p. 45		
Dimensions		
See p. 61		



# Control Units

## Sizing of the DIGIPACT Internal Bus

Sizing of the DIGIPACT internal bus depends on two factors:

- The number of devices on the bus
- The length of the bus

## Number of Devices

As on any communications network, the number of devices that may be connected on the DIGIPACT internal bus is limited. The maximum number of devices is calculated in terms of "communication points." Each type of device represents a number of points indicated in the table below. The total number of points for the various devices connected to a single bus must not exceed 100. If the required devices represent more than 100 points, simply add a second DIGIPACT internal bus with a second DC150 data concentrator. The same sizing rules apply to the second bus as well.

Communicating Device	Number of Points
DC150 Data Concentrator	4
Communicating Auxiliary Switches OF, SD, SDE for COMPACT® NS Circuit Breakers	2
Communicating Motor Operator and Auxiliary Switches for COMPACT NS Circuit Breakers	2
Communicating Auxiliary Switches CE and CD for COMPACT NS Circuit Breakers	0
SC150 Indication and Control Interface	4
CLS150 Indication and Local Control Module Associated with:	
■ Communicating Auxiliary Switches	0
■ Communicating Motor Operator and Auxiliary Switches	0
■ SC150 Indication and Control Interface	0
PM150 Power Meter	4
ATB MULTI 9 Interface	2

## Length of Bus

The table below indicates the cross-sectional area of the cable that must be used depending on the total length of the bus.

Cross-sectional Area	Maximum Length of Bus
0.03 in. <sup>2</sup> (0.75 mm <sup>2</sup> )	660 ft. (200 m)
0.06 in. <sup>2</sup> (1.5 mm <sup>2</sup> )	1310 ft. (400 m)
0.1 in. <sup>2</sup> (2.5 mm <sup>2</sup> )	2300 ft. (700 m)

The total resistance of the two wires for the bus must be less than 12 ohms. If the bus is too long, simply:

- Increase the cross-sectional area of the cable.
- Create two shorter buses for the installation (in this case, a second DC150 data concentrator is required).



**Location**

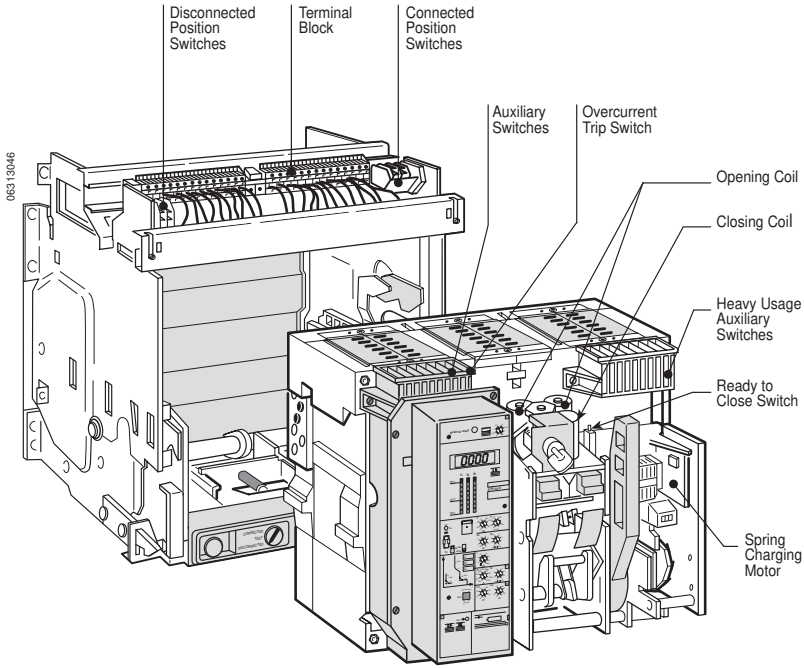

**Secondary Disconnects**

Electrical accessories are UL Listed for field installation per UL file E113554. They are provided with terminals and located on secondary disconnecting blocks above the circuit breaker:

- Fixed-mounted: By one or two connecting plugs (provided).
- Drawout-mounted: To terminal block **A** located in the front of the stationary assembly for easy access. (This terminal block is then wired to another connection block **B** that operates automatically to isolate the internal accessories when the circuit breaker is in the disconnected position.)



**Fixed-mounted Circuit Breaker**



**Drawout-mounted Circuit Breaker**

**Additional Connections (BS):**

Single connection only is allowed in the terminal block. Multiple connections have to be made by adding extra terminals in the block located on the stationary assembly. The BS option consists of five additional terminals.

**Connection:**

Accessory terminals are maintenance-free and may be connected by standard #18 to #14 AWG copper wires. Cable strip length: 3/8 in. (10 mm).



## Accessories

The MASTERPACT circuit breaker is equipped with a true two-step stored energy mechanism which ensures fast opening and closing operations and complete open-close-open sequence without recharging the mechanism. The MASTERPACT circuit breaker has manual actuators that include a charging handle and push-to-open and push-to-close buttons. In addition, remote operation is possible with the following field-installable accessories:

- Spring charging motor (MCH)
- Closing release (XF)
- Undervoltage trip device (MN) or shunt trip (MX) for opening

The manual operating mechanism can still be used in an emergency. The addition of the electrical operating mechanism does not alter circuit breaker dimensions.

### Spring-charging Motor (MCH)

The spring-charging motor automatically charges the stored energy mechanism (when the circuit breaker closes) making O–C–O cycles possible without recharging. Opening and closing operations are instantaneous.

<b>Control Voltage (V)</b>	60 Hz	120–240
	DC	24–48–125
<b>Consumption</b>	AC	180 VA
	DC	180 W
<b>Inrush Current</b>	2 to 3 x I <sub>n</sub> for 0.1 sec.	
<b>Charging Time</b>	3 to 4 sec.	

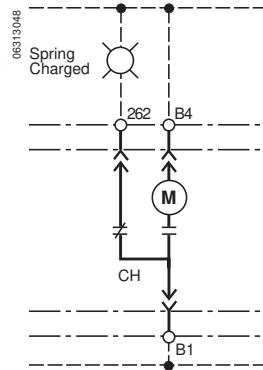

### Operation Counter (CDM)

With spring-charging motor option only. The operation counter is read from the front and gives the total number of circuit breaker operating cycles.

### Spring-charged Switch

This type "b" switch is closed when the spring is charged. It comes standard with the spring charging motor and is provided with a common terminal.

Max. Current (A)		
60 Hz	240 V	10
DC	125 V	0.5
	250 V	0.25

06313047

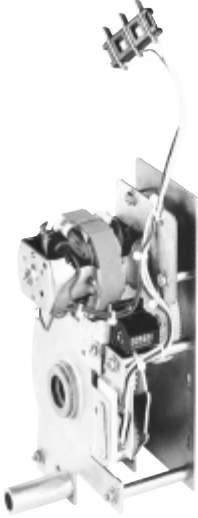

06313049



### Closing Coil (XF)

This device releases the circuit breaker closing mechanism when the spring is charged. The closing coil is rated for continuous duty. The closing release is supplied on request and can be fitted even on a manual operating mechanism.

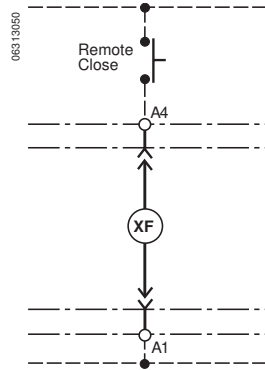

### Anti-pumping Function

When the closing coil (XF) is permanently energized, the circuit breaker remains in the open position after it has been opened, either by manual or electrical operation. The circuit breaker can only be closed if the closing coil is momentarily de-energized (see p. 32).

*Note: This anti-pumping function can be disabled by series connecting a ready-to-close ("b" contact) switch (PF) to the closing coil.*

<b>Circuit Breaker Closing Time</b>	Less Than 80 ms	
<b>Operating Voltage Range</b>	0.85 to 1.1 x Rated Voltage	
<b>Control Voltage (V)</b>	60 Hz	120–240
	DC	24–48–125
<b>Consumption (Inrush and Sealed)</b>	60 Hz	20 VA
	DC	15 W



**Opening Coils**

Three types of voltage releases can be used for remote opening of the circuit breakers:

- Shunt trip (MX)
- Instantaneous undervoltage trip device (MN)
- Time-delayed undervoltage trip device (MNR)

**Possible Combinations**

Each MASTERPACT circuit breaker can be equipped with:

- One shunt trip (MX) + one undervoltage trip device (MN or MNR)
- Or two shunt trips (MX)

**Shunt Trip (MX)**

This release is rated for continuous duty and operates with control voltages between 85% and 110% of its rating. However, when series connected with an "a" auxiliary switch, the shunt trip can be operated with 55% or more of its rated voltage and can be used for ground-fault protection when combined with a Class 1 ground-fault sensing element. The shunt trip is field-installable.

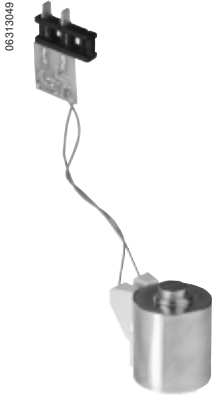

Control Voltage (V)	
60 Hz	120–240–480
DC	24–48–125–250
Consumption (Inrush and Sealed)	
AC	20 VA
DC	15 W
<b>Operating Time</b>	40 ms

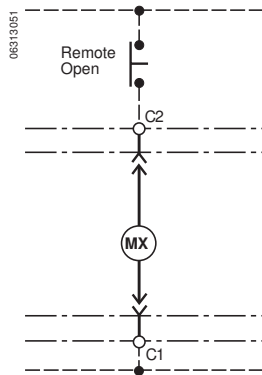

**Instantaneous Undervoltage Trip Device (MN)**

This release instantaneously opens the circuit breaker when supply voltage drops below a value between 35% and 70% of rated voltage. If the release is not energized, the circuit breaker cannot be closed (either manually or electrically). Any attempt to close it will have no effect on the main contacts. Closing is possible when the release voltage reaches 85% of its rated value. The instantaneous undervoltage trip device is field-installable.

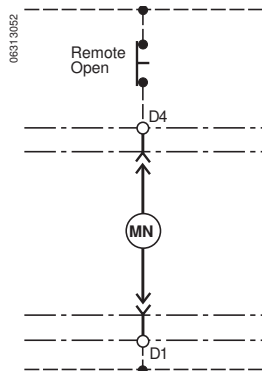

**Time-delayed Undervoltage Trip Device (MNR) (1)**

To prevent the circuit breaker from tripping in the event of transient voltage drops, this release has a built-in adjustable time delay. If required, this time delay can be overridden by connecting an external switch on an additional circuit (wired by the user). The undervoltage trip device is field-installable.

	MN	MNR (1)
<b>Control Voltage (V)</b>		
60 Hz	120	120
	240	—
	480	480
DC	24	—
	48	—
	125	—
	250	—
<b>Consumption (Inrush and Sealed)</b>		
AC	20 VA	20 VA
DC	15 W	15 W
<b>Operating Time (s)</b>		
	0.09	0.5–0.9–1.5–3

(1) Not UL Listed.

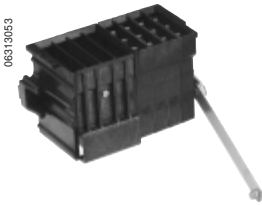

**Heavy Usage Auxiliary Switches (OF)**

Four SPDT switches with double break construction. They are directly operated by the main contacts and ensure a large insulation distance in open position. They are therefore particularly suitable for insulation of auxiliary circuits or reliable interlockings.

- "a" contacts are open when the circuit breaker is open and closed when the circuit breaker is closed.
- "b" switches are closed when the circuit breaker is open and open when the circuit breaker is closed.

See page 30 for operating diagrams. Auxiliary switches are field-installable.

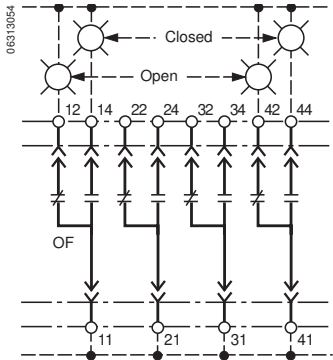

## Accessories

06313055



### 24 Additional Auxiliary Switches (OFSUP)

An external plate holds a set of 24 SPDT switches operated by means of a cable. They are available only for drawout circuit breakers.

### Standard Auxiliary Switches (O and F)

2a + 2b switches available as standard:

- "a" contacts are open when the circuit breaker is open and closed when the circuit breaker is closed.
- "b" switches are closed when the circuit breaker is open and open when the circuit breaker is closed.

See page 30 for operating diagrams.

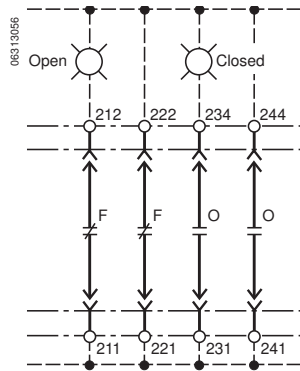

### Ready-to-close Switch (PF)

This SPDT switch indicates that the circuit breaker is ready to close and that the following conditions exist:

- The circuit breaker is open
- The stored energy mechanism is charged
- The control unit is reset
- The circuit breaker opening push button is neither locked nor padlocked
- The circuit breaker is in the fully-connected or test position

The switch is field-installable.

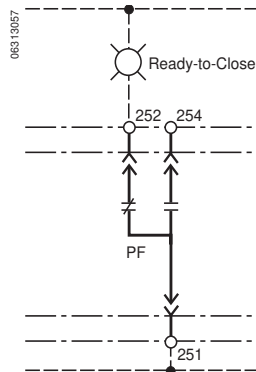

**Connected Position Switches (CE)**

A block of four SPDT switches operate when a drawout circuit breaker is in the connected position. The switch block is field-installable.

**Disconnected Position Switches (CD)**

A block of two SPDT switches operate when a drawout circuit breaker is in the disconnected position. The switch block is field-installable. See page 30 for operating diagrams.

**Test Position Switch (CT)**

One SPDT switch is operated only when the circuit breaker is in the test position. The switch is field-installable.

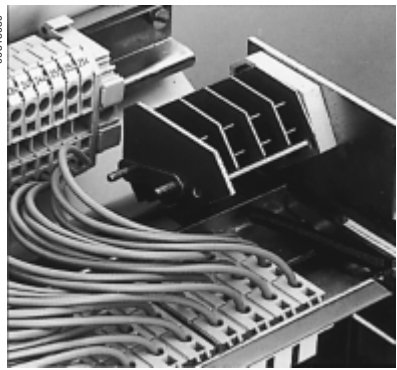
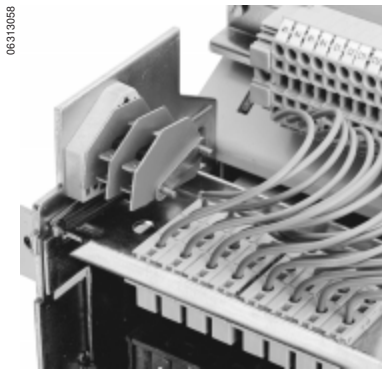

Disconnected Position Switches (CD)

Connected Position Switches (CE)

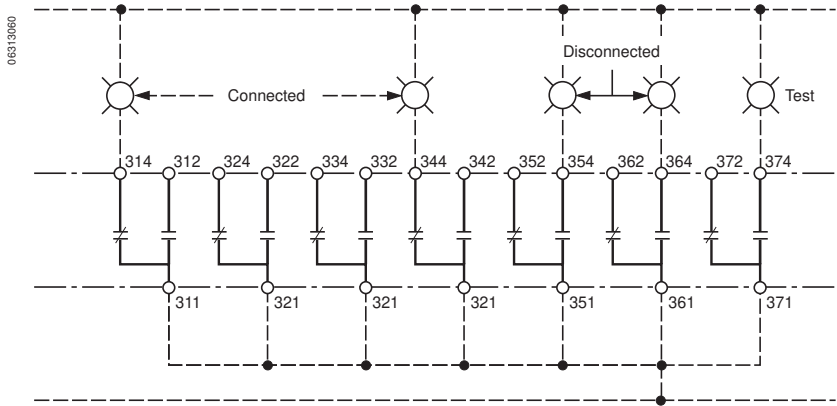

Connection by 1/4 in. Male Quick Connect Terminal

**Current Ratings (A)**

Voltage (V)	Auxiliary Switch			Ready-to-close Switch	Position Switch		
	Heavy Usage	Standard	24 Additional		Connected	Disconnected	Test
60 Hz	240	10	15	12	15	15	15
	480	10 (1)	6		6	6	6
	600	6	3		3	3	3
DC	125	3	0.5		0.5	0.5	0.5
	250	3	0.25		0.25	0.25	0.25

See page 65 for IEC voltage ratings.  
(1) 8 A for MC08.



# Accessories

## Operating Diagrams

### Auxiliary Switches

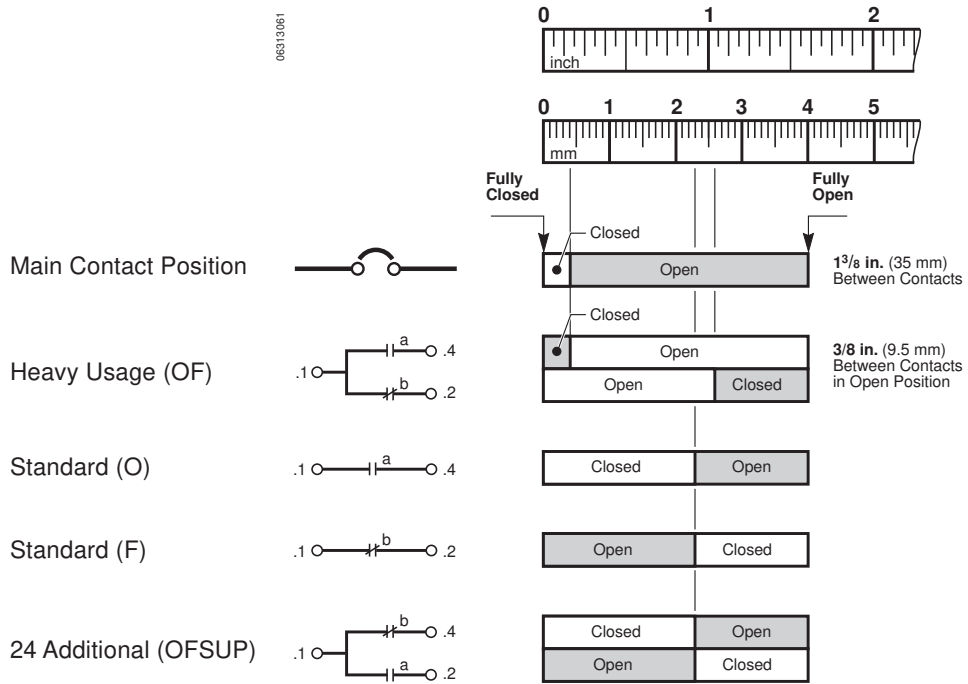

Note: Contacts are shown with the circuit breaker in the open position. Scale applies only to distance between main contacts.

### Position Switches

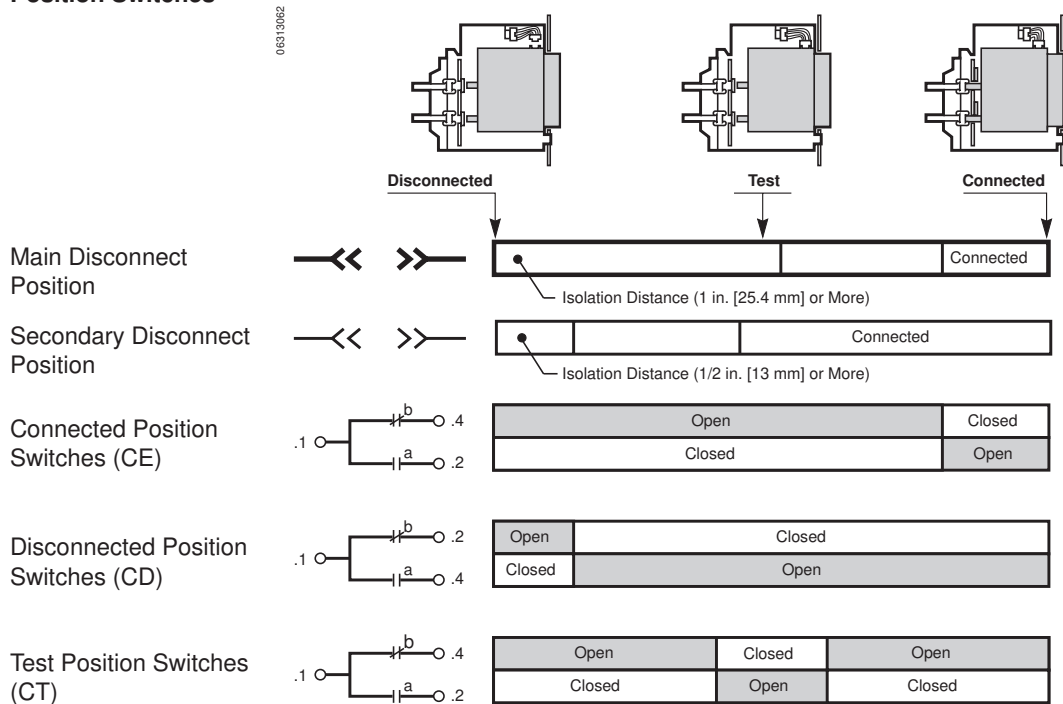

Note: Position switches are shown with the circuit breaker in the connected position.



## Push Button Locking Device (VBP)

This device prevents local manual operation of the circuit breaker by covering the opening and/or closing the push buttons. This locking device can be locked by a padlock or a sealing lead.

## Open Position Lock (VSKA)

A key interlock that locks the circuit breaker in the open position by holding the push button in its depressed position. The key interlock is provided.



Push Button Locking Device (VBP)



Open Position Lock (VSKA)



## Door Interlock (VPEC)

This lock prevents the compartment door from being opened when the circuit breaker is in the connected position. If the circuit breaker is put into the "connected" position with the door open, the door can be closed without disconnecting the circuit breaker.

*Note: For greater protection, this interlock can be used with racking interlock (VPOC) below.*

## Racking Interlock (VPOC)

This lock prevents racking in the circuit breaker when the door is open. (Insertion of the circuit breaker racking crank is not possible when the compartment door is open.)

## Disconnected Position Locking

The circuit breaker can be locked in the disconnected position by means of one to three padlocks (padlocks not provided) or one key interlock (factory-mounted option VSKC). The key interlock is on the stationary assembly and accessible with the cubicle door locked.

*Note:*

- Key interlock is of the captive key type, free when locked.
- By special order, locking may be possible on disconnected, test and connected positions (VSKEC).

## Spring Charge Interlock (VEAA)

This selection is for a device that prevents the circuit breaker or switch from being fully withdrawn from its cradle when the closing spring is charged. It is standard for ANSI (UL1066) circuit breakers and an option on others. The VEAA interlock is not compatible with undervoltage releases (MN, MNR or MNRI).

**Mechanical Interlocks**

- **Disconnecting When Circuit Breaker Is Closed:**  
 During any disconnecting attempt when the circuit breaker is closed, an interlocking device ensures the tripping of the circuit breaker before the actual separation of the main disconnects. The circuit breaker remains, however, operable in the other positions: test, disconnected and withdrawn.
- **Circuit Breaker Closing When Not Completely Connected:**  
 The interlocking device mentioned above prevents closing of the circuit breaker if the connecting operation is not completely achieved.
- **Connecting Circuit Breaker When Door Opened:**  
 VPEC and VPOC options prevent the compartment door from being opened when the circuit breaker is in the connected position and from connecting the circuit breaker when the door is open.

**Electrical Interlocks**

- **Priority of Opening Orders (Standard):**  
 Opening coils (undervoltage trip devices, shunt trip) and opening push button have priority over the closing coils and closing push button.
- **Mechanical Pop-out Type Indicator (Standard):**  
 Under overcurrent or ground-fault conditions, the trip indicator located in the control unit will pop out. It is not possible to close the circuit breaker until this trip indicator is reset. This standard function can be disabled upon request.
- **Anti-pumping Function (Standard):**  
 In case the closing coil (XF) becomes permanently energized, the circuit breaker remains in the open position **A** after it has been opened, either by manual or electrical operation. The circuit breaker can be closed only if the closing coil is momentarily de-energized **B**.  
*Note: This anti-pumping function can be disabled by series connecting a "ready to close" (NC contact) switch (PF) with the closing coil (XF).*

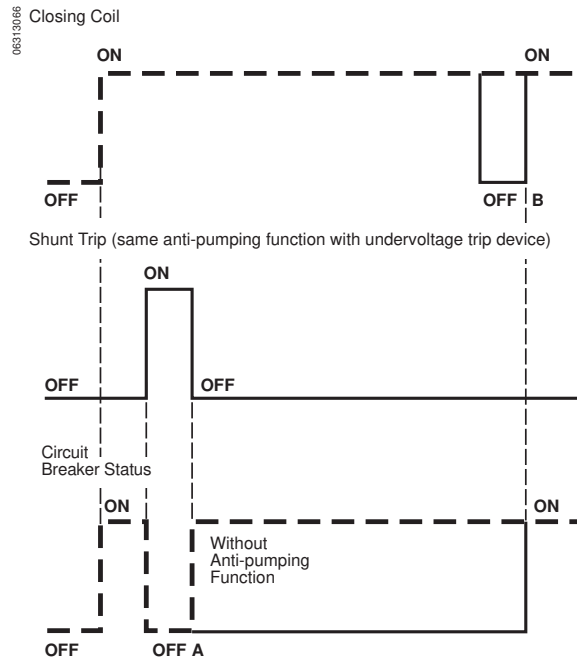

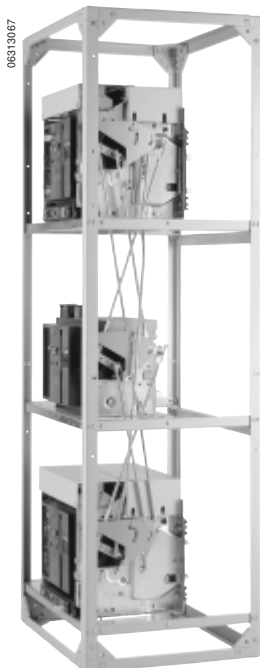

### Interlocking Rods and Cables

Two or three MASTERPACT circuit breakers can be mechanically interlocked by means of rods or cables. This accessory is mountable on the right side of the circuit breaker. This adaptation can be made on site without modifying the circuit breaker.

#### Mechanical Interlock Between Two or Three Stacked Circuit Breakers

This interlocking is obtained by the joining of:

- One adaptation block
- One or two adjustable and nonadjustable rods

Maximum distance between the two fixing surfaces of the devices: 35 in. (0.89 m)

#### Mechanical Interlocks Between Two Side-by-Side Circuit Breakers

This interlocking is obtained by the joining of:

- One adaptation block
- One set of adjustable cables with a maximum length of 78 in. (2 m)

### Possible Mounting Arrangements Among Three Stacked Circuit Breakers

One use, power supplied by:

- Two transformers N1 and N2 which are connected in parallel
- Or one standby source G

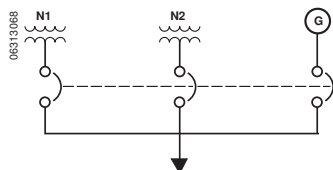

Two uses, independently powered supply by two transformers N1 and N2, standby through a circuit breaker or a connection tie switch, preventing the connection in parallel of the two current transformers.

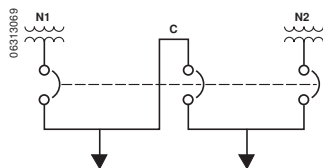

One use, power supplied by one group of transformers N1, N2 or N3 or of generators, preventing any connection in parallel.

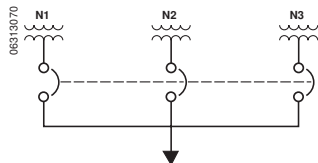

## Accessories

### Safety Shutters (VO)

Comprising two independent parts, line and load side, the safety shutters automatically block access to the main disconnects when the circuit breaker is in the disconnected, test or fully withdrawn position.

### Shutters Lock (VVC)

A factory-mounted movable and lockable slide (padlock not supplied) is used to:

- Lock the line or load shutters in the closed position
- Hold the line or load shutters in the open position

A support is provided at the back of the stationary assembly to hold the slide when not in use.



**Safety Shutters**

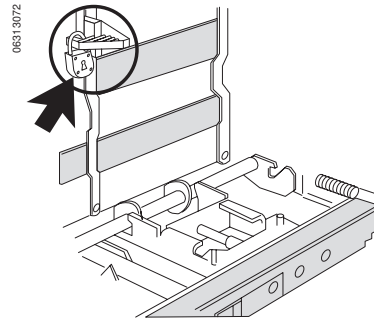

**Shutters Lock**

### Rejection Feature (VDC)

The rejection feature ensures that only the properly designated circuit breaker is matched with the selected cradle assembly. It is made of two parts (one for the frame and one for the stationary assembly), and allows 20 different combinations.

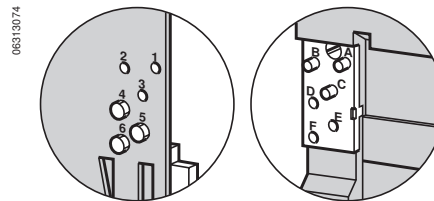
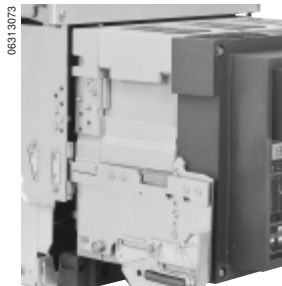

**Stationary Assembly**

**Circuit Breaker Frame**

### Possible Arrangements

Frame	Stationary Assembly	Frame	Stationary Assembly
A-B-C	4-5-6	B-C-D	1-5-6
A-B-D	3-5-6	B-C-E	1-4-6
A-B-E	3-4-6	B-C-F	1-4-5
A-B-F	3-4-5	B-D-E	1-3-6
A-C-D	2-5-6	B-D-F	1-3-5
A-C-E	2-4-6	B-E-F	1-3-4
A-C-F	2-4-5	C-D-E	1-2-6
A-D-E	2-3-6	C-D-F	1-2-5
A-D-F	2-3-5	C-E-F	1-2-4
A-E-F	2-3-4	D-E-F	1-2-3



### Interphase Barrier (EIP)

Mounted between terminals of the stationary assembly, the interphase barrier prevents arc prolongation to the circuit breaker in the event of a line side fault and isolates the circuit breaker connections in insulated bus bar installations.

### Transparent Cover (CB)

Hinged-mounted and locked with a milled head, this cover is designed to be installed on the door escutcheon. It provides a higher degree of protection and is suitable for drawout or fixed-mounted circuit breakers.

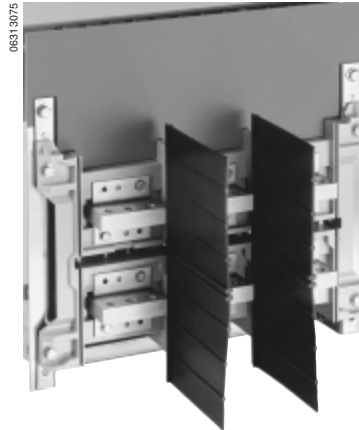

Interphase Barrier



Transparent Cover

# Switch

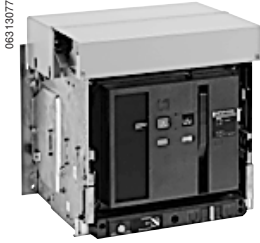

## Ratings

Type	Ampere Rating (A)	Short-time Rating (RMS Sym. Amperes) 600 Vac Max.	Short-circuit Withstand When Protected by a MASTERPACT Circuit Breaker (A)	
			Max. Frame (A)	600 Vac Max.
MP08 NA	800	50,000	800	50,000
MP12 NA	1200	50,000	1200	50,000
MP16 NA	1600	50,000	1600	50,000
MP20 NA	2000	50,000	2000	50,000
MP25 NA	2500	50,000	2500	50,000
MP30 NA	3000	50,000	3000	50,000
MP40 NA	4000	85,000	4000	85,000
MP50 NA	5000	85,000	5000	85,000
MP63 NA (1)	6300	85,000	6300	85,000

(1) Not UL Listed.

### CAUTION

#### HAZARD OF EQUIPMENT DAMAGE.

This switch contains no overcurrent protection. It is suitable for use at its ampere rating when protected by a MASTERPACT circuit breaker of the same ampere rating.

**Failure to observe this precaution can cause equipment damage.**

## Construction

The MASTERPACT switch is identical to the MP circuit breaker, except that the switch is not equipped with current transformers or an actual control unit. However, it does have an STR08 dummy unit.

## Accessories, Dimensions and Connections

Switch accessories, dimensions and connections are identical to those of the corresponding circuit breaker, except that the overcurrent trip switch is not available with the switch version.

	Page
Accessories	23
Wiring diagrams	42
Circuit Breaker Dimensions	46



Overcurrent Protection STR 28D Control Unit

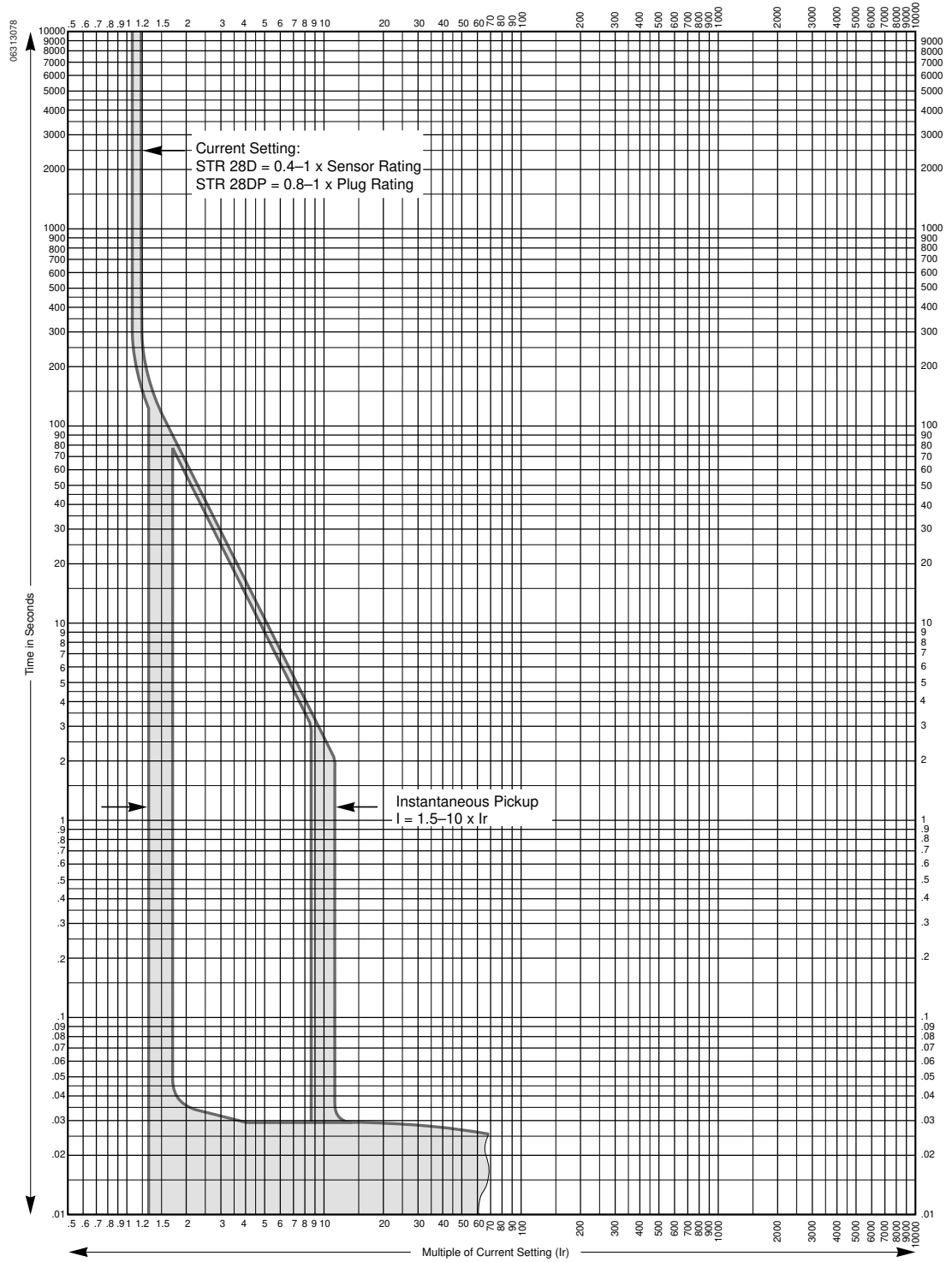

# Trip Curves

## Overcurrent Protection STR 38S Control Unit

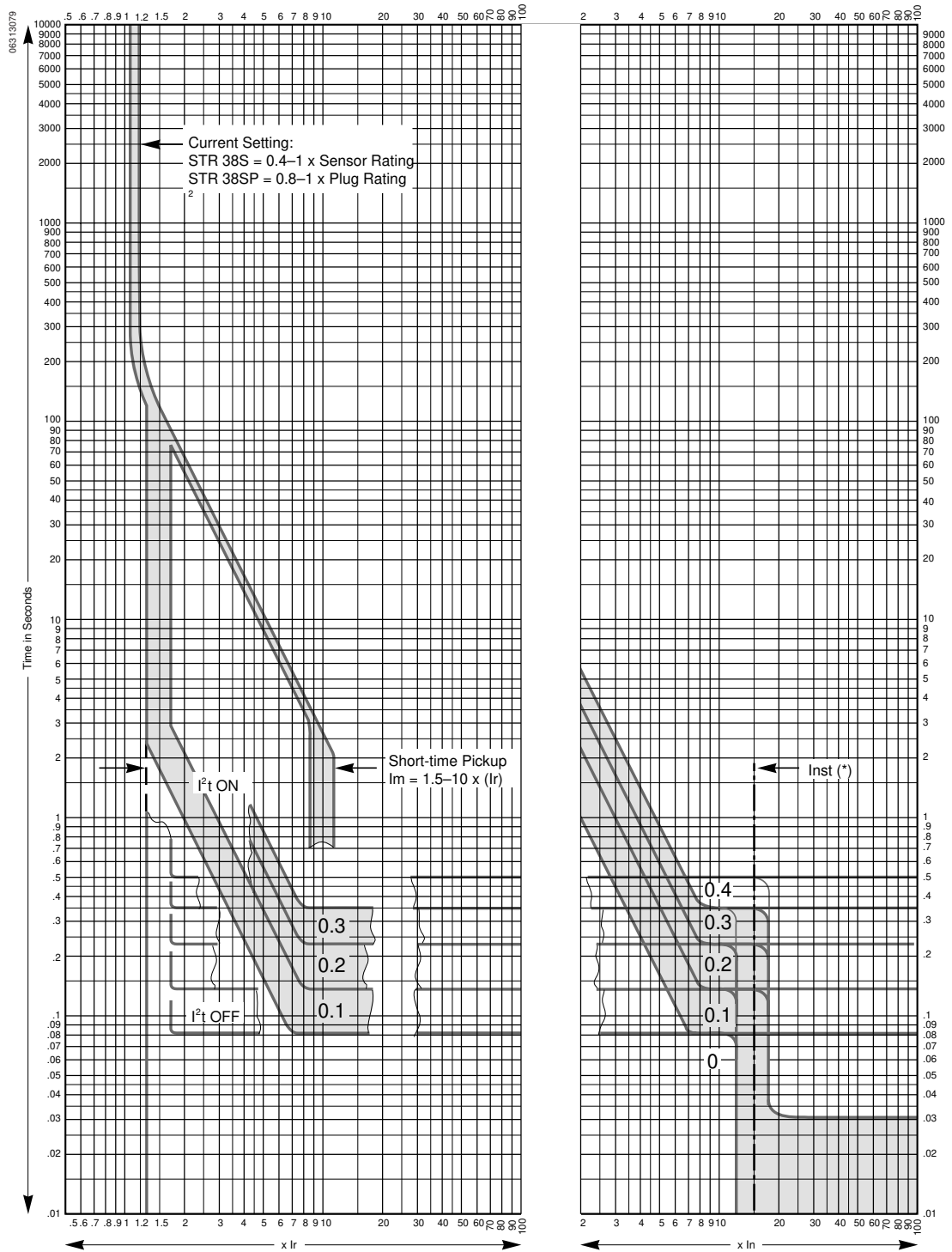

(\*) Instantaneous

Rating	$I_n$ (A)	630	800/1000	1200/1600	2000	2500	3000/3200	4000/5000/6300
Fixed Threshold	$I = I_n \times \dots$	28	28	24	20	14	12	10



Overcurrent Protection STR 58U Control Unit

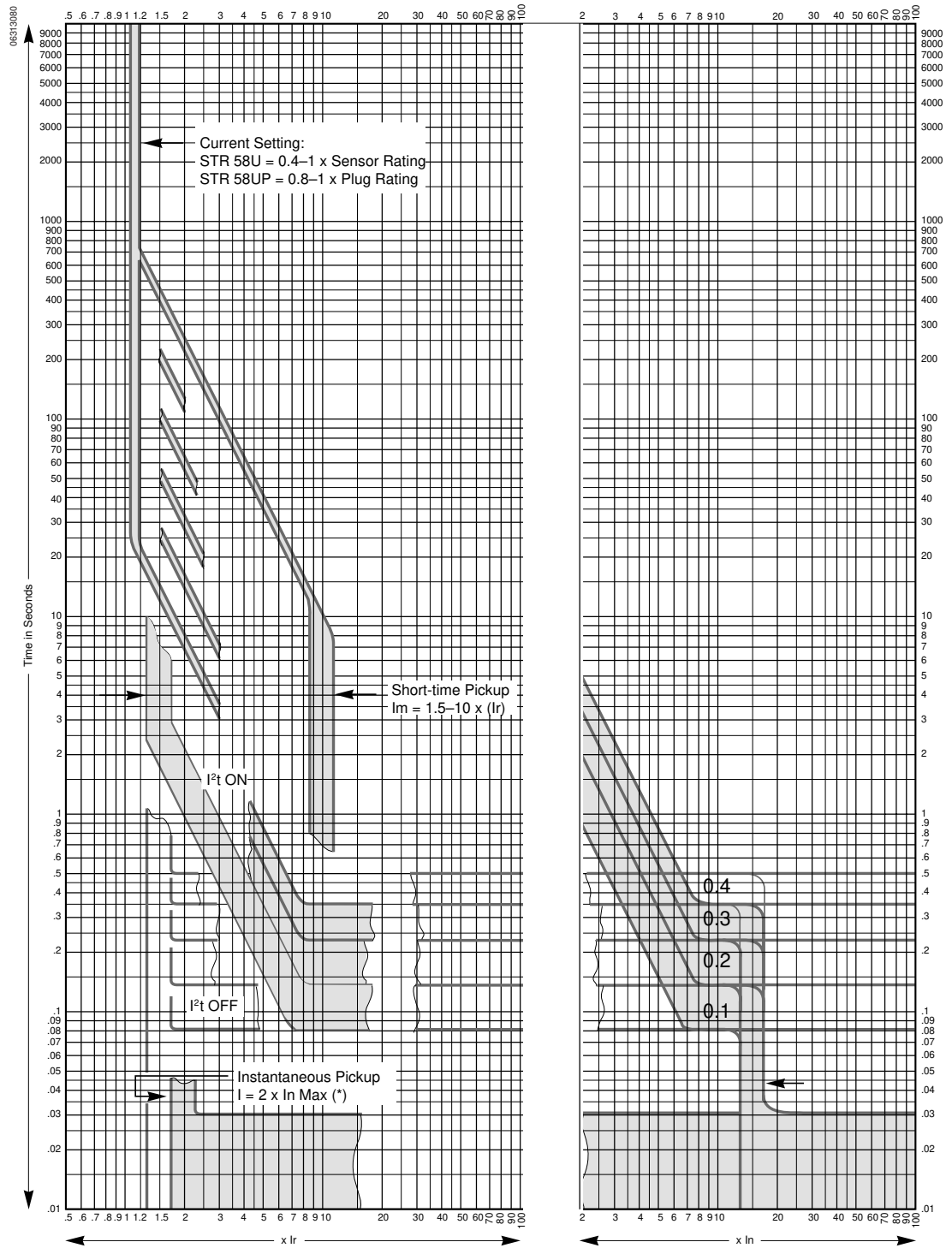

Instantaneous Dial Settings

800/1000 A

H1: 2-4-8-12-14-19-22-Off  
 H2: 2-4-8-12-14-19-22-Max.

1200/1600 A

H1: 2-4-8-12-14-17-22-Off  
 H2: 2-4-8-12-14-17-22-Max.

2000 A

H1: 2-4-8-10-12-14-17-Off  
 H2: 2-4-8-10-12-14-17-Max.

2500 A

H1: 2-4-6-8-10-12-12-Off  
 H2: 2-4-6-8-10-12-12-Max.

3000/3200 A

H1: 2-4-6-8-10-10-10-Off  
 H2: 2-4-6-8-10-10-10-Max.

4000/5000/6300 A

H1: 2-4-6-8-8-8-8-Off  
 H2: 2-4-6-8-8-8-8-Max.

(\*) Instantaneous

Rating	$I_n$ (A)	630	800/1000	1200/1600	2000	2500	3000/3200	4000/5000/6300
Maximum Threshold	$I = I_n \times x$	28	28	24	20	14	12	10



# Trip Curves

## Ground-fault Protection STR 38S-STR 58U Control Units

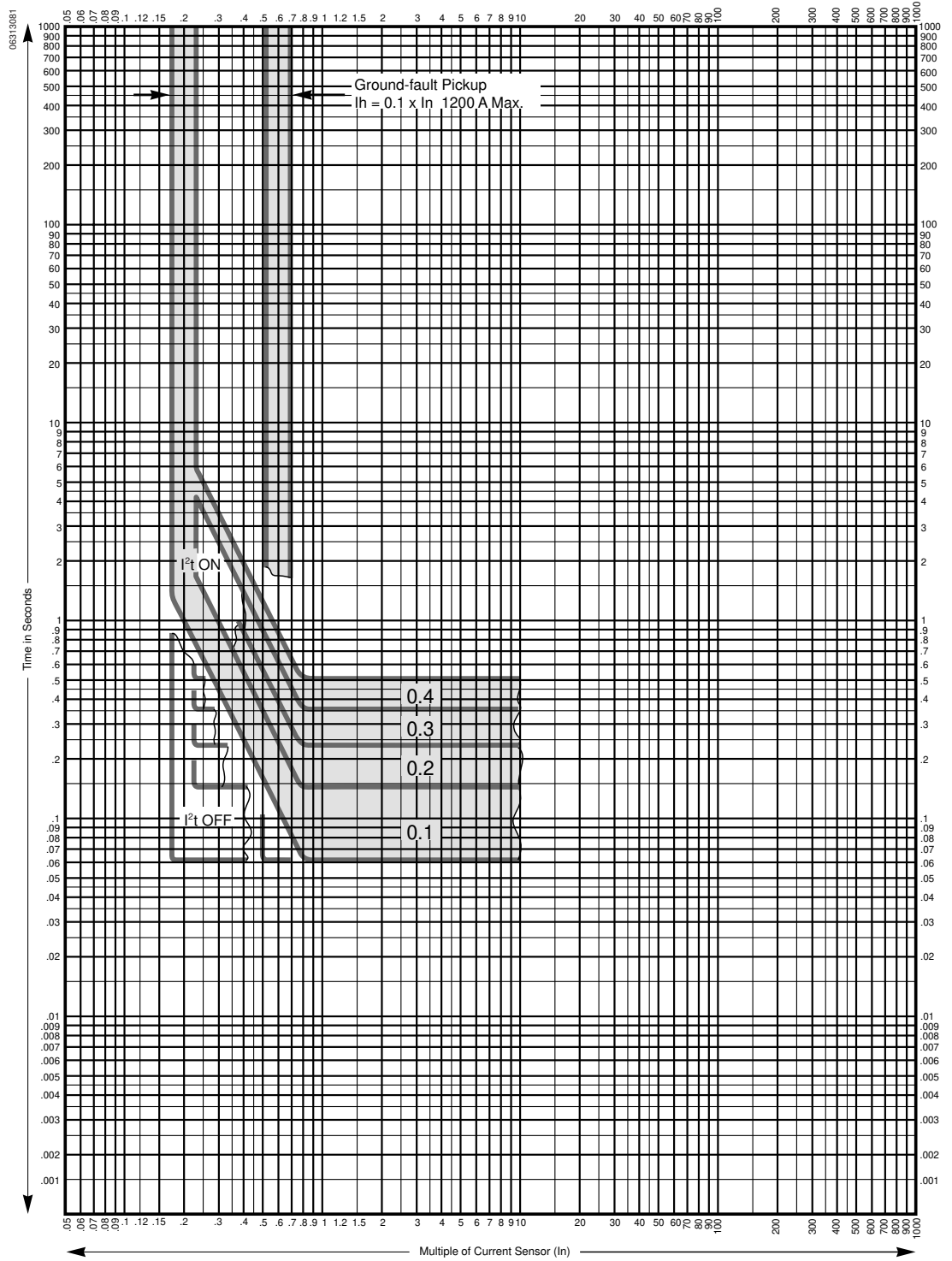

Load Monitoring STR 58U Control Unit

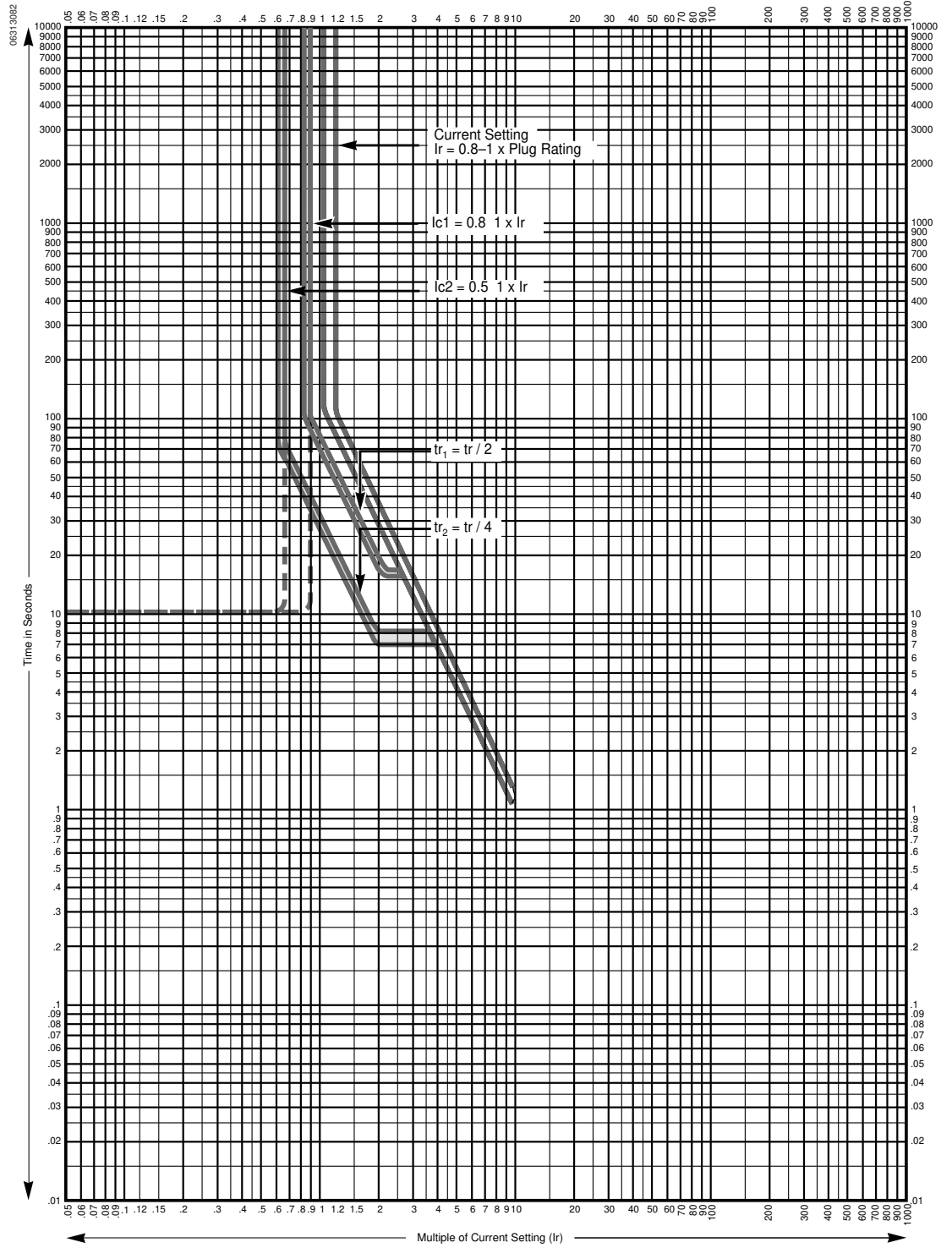

# Wiring Diagrams

Diagram No. 689 889

06313083

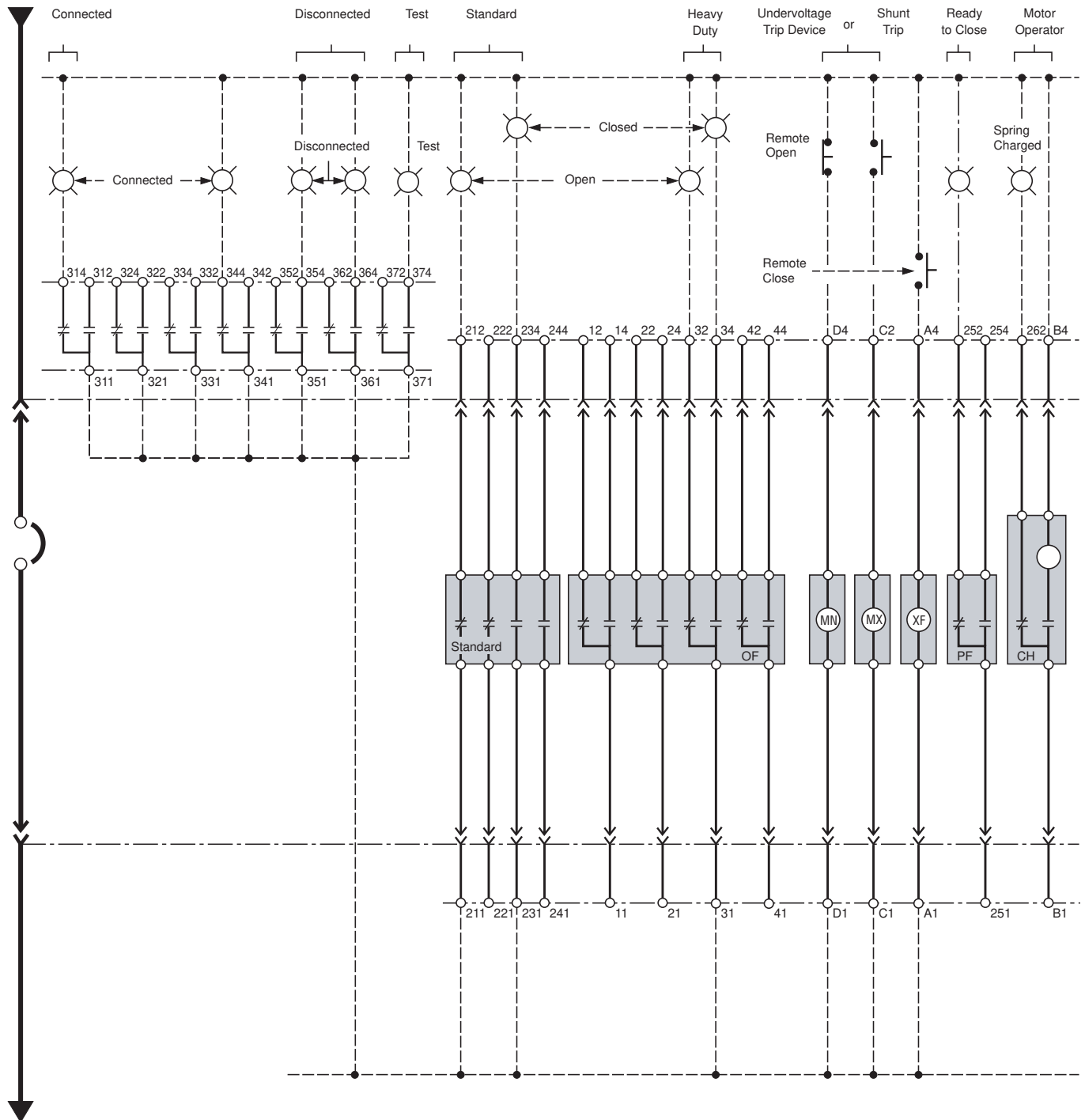
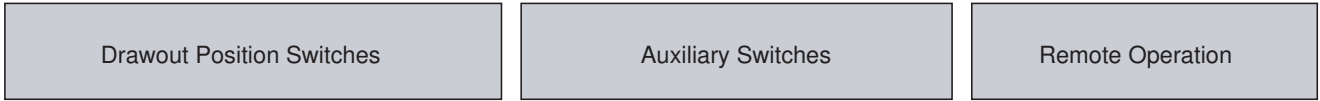

Note: Circuit breaker shown in connected, charged and open position with undervoltage releases energized.



Diagram No. 689 889

06313054

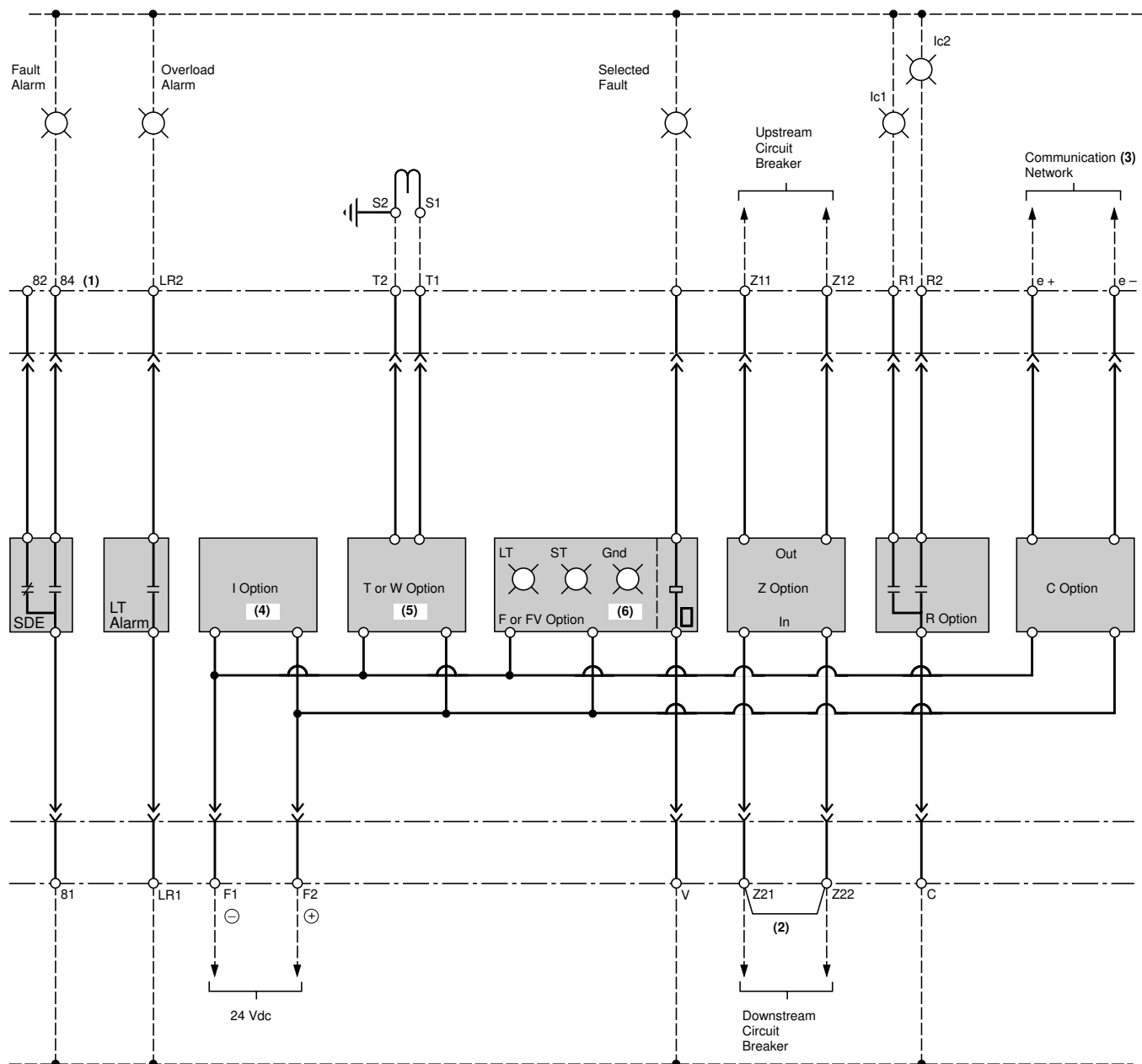
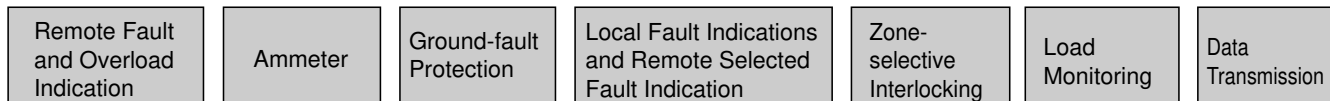

- (1) 84 terminal not available with Z or C option.
- (2) Zone-selective interlocking with downstream circuit breaker: remove the jumper.
- (3) Communication output through DIGIPACT module.
- (4) Use 24 Vdc supply for loads less than 20% of current sensor rating, or one-phase load less than 40% of sensor rating.
- (5) Use 24 Vdc supply for lower setting.
- (6) Use 24 Vdc supply for F option if not supplied with PIL (battery) option; use 24 Vdc supply (mandatory) for FV option.



# Wiring Diagrams

## SC150 Indication and Control Interface

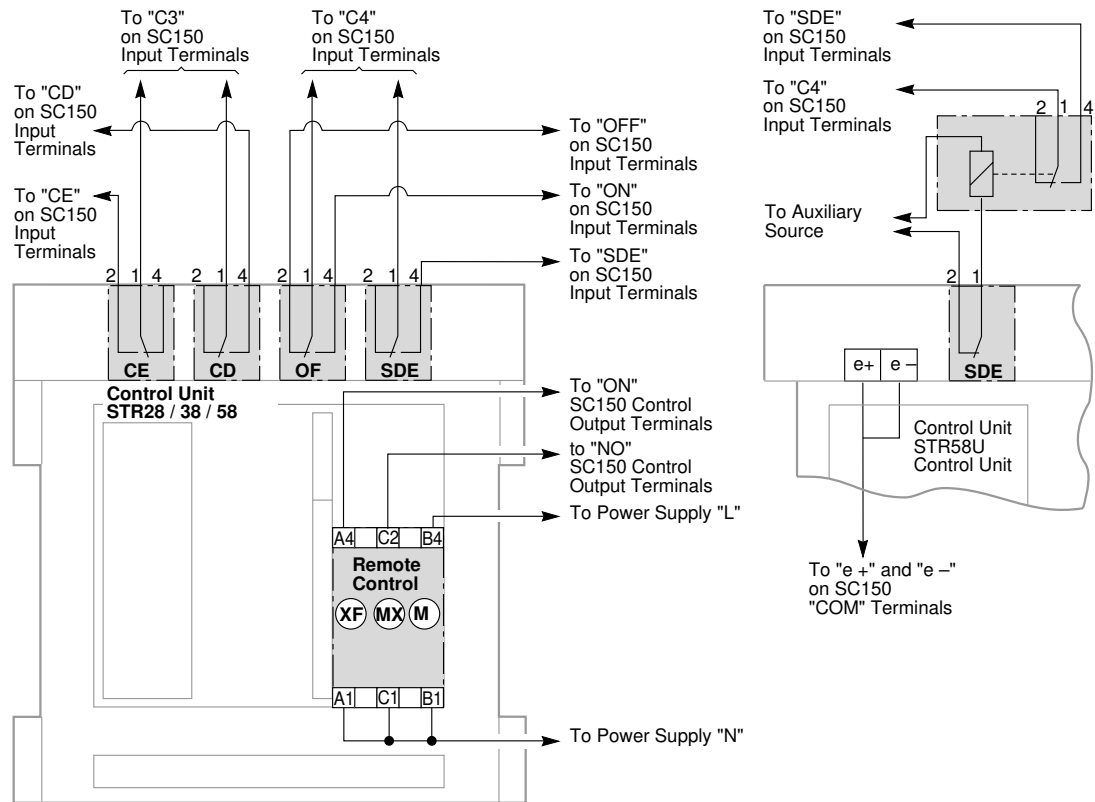
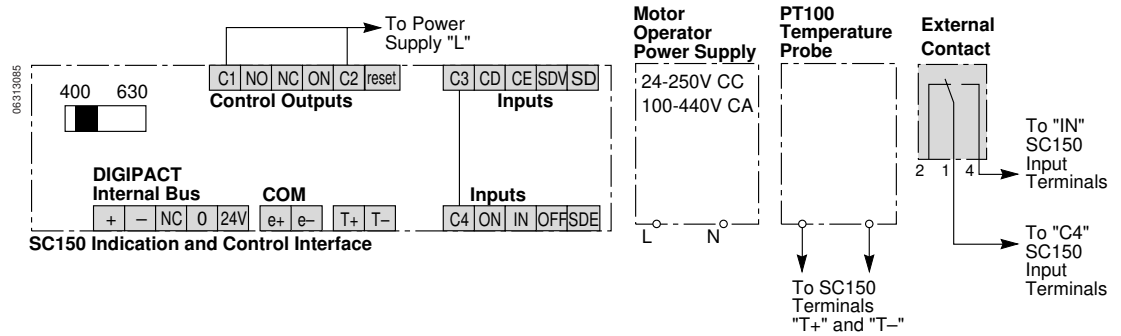

### Internal Bus

Marking	Color
24 V	Red
0 V	Black
Internal Bus -	White
Internal Bus +	Blue



## DC150 Data Concentrator

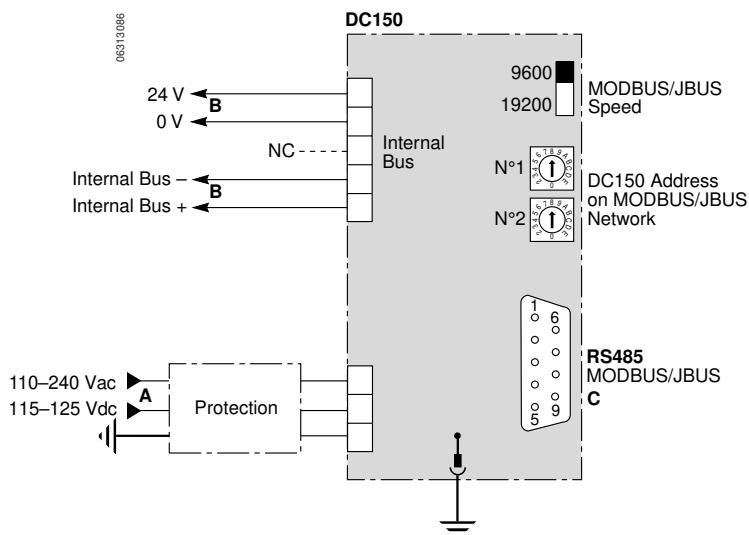

### Connectors

The DC150 concentrator is connected using a SUBD9 male connector with a metal hood (e.g., ITT canon, DE9P K83 + hood or DE115-500-5-RD). The DC150 concentrator is equipped with a SUBD9 female connector. For a multidrop configuration, the tap-offs can be made either via a branching off of RS485 connector Catalog No. 50788 or standard connection boxes, taking care to respect the necessary precautions when connecting the shieldings. The adaptation of an RS232 output on a personal computer to accept the RS485 standard connector should be done with the RS485/RS232 converter Catalog No. 50786.

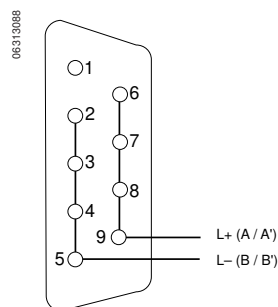
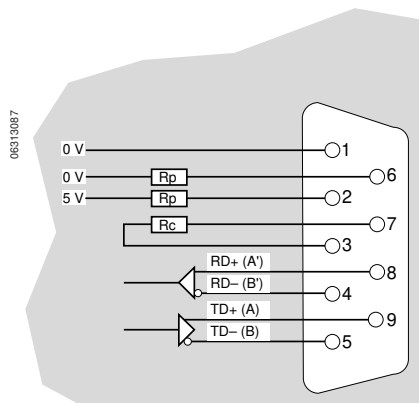

**DC150 Concentrator with Polarization and 2-wire Adaptation**

### Recommended Protection and Cable Sizes

Recommended Protection	Type	Catalog No.
C60N Supplementary Circuit Protector Curve C-10 A	3-Phase	MG24466 or 24214
Fuse-link 10 A	aM	15660
Marking (1)	Connection	Cable
<b>A</b>	Voltagés	0.06 to 0.1 in. <sup>2</sup> (0.75 to 2.5 mm <sup>2</sup> )
<b>B</b>	Internal Bus	0.03 to 0.1 in. <sup>2</sup> (0.75 to 2.5 mm <sup>2</sup> ) (Twisted)
<b>C</b>	MODBUS/JBUS	0.03 to 0.1 in. <sup>2</sup> (0.75 to 2.5 mm <sup>2</sup> ) (Shielded)
Internal bus	Marking	Color
	24 V	Red
	0 V	Black
	Internal Bus -	White
	Internal Bus +	Blue

(1) See first drawing above.



# Circuit Breaker Dimensions

## Door Escutcheon (Drawout Mounting)

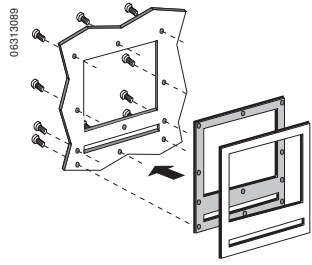

**Door Cutout**

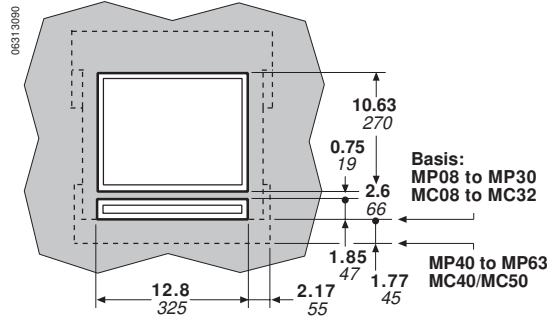

**Drilling of the Door**

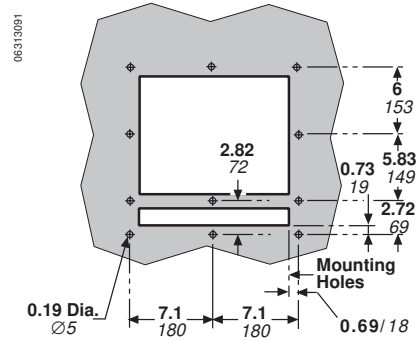

## Door Escutcheon (Fixed Mounting)

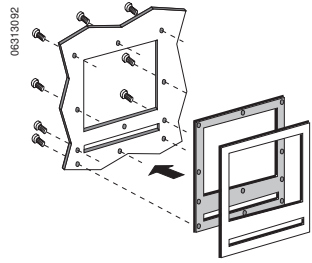

**Door Cutout**

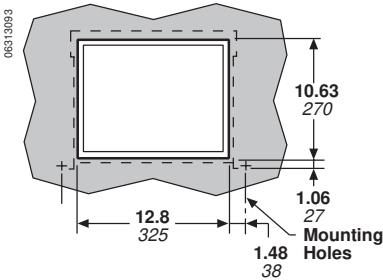

**Drilling of the Door**

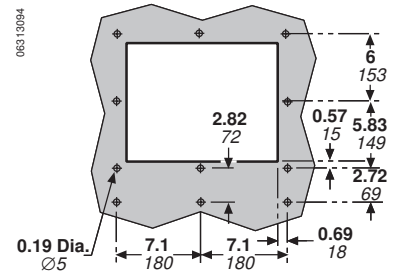

Note: Refer to shop drawings for verification.

## Door Interlock

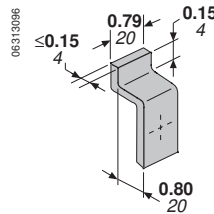
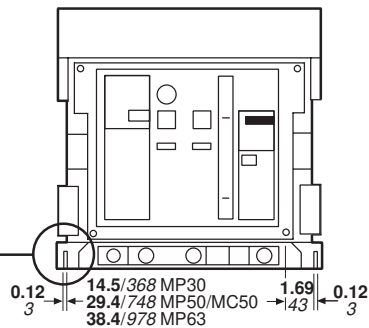
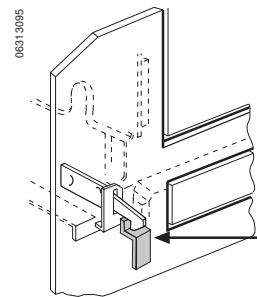

**Rear Cutout**

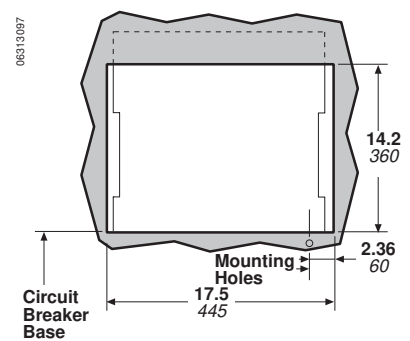

Note: The door interlock can be mounted on either the right side or the left side of the circuit breaker.

Dimensions: inch  
mm



## External Neutral Sensor

MP08 to MP20, MC08 to MC20      MP25/MP30/MP40, MC32/MC40

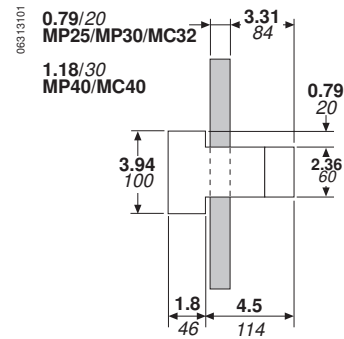
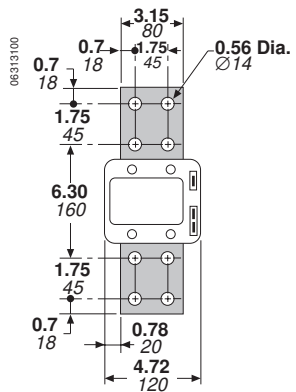
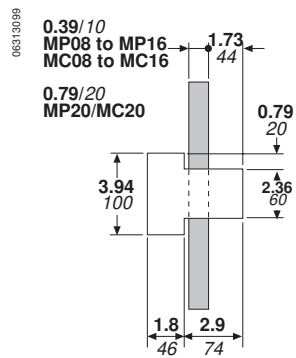
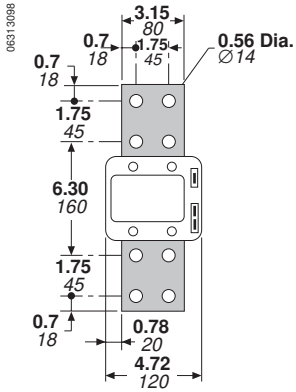

## MP50 to MP63

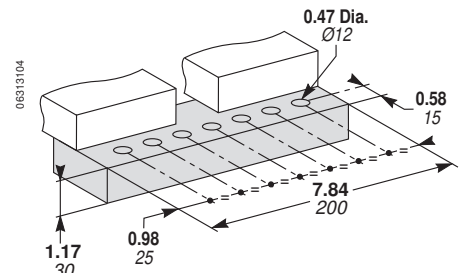
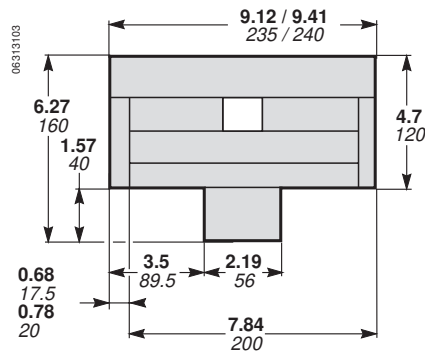
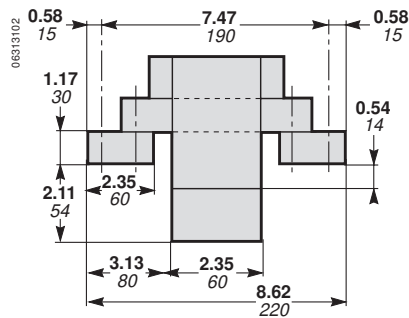

Dimensions: inch  
mm



# Circuit Breaker Dimensions

## MP08–MP12–MP16 Fixed Mounting

### 3-Pole

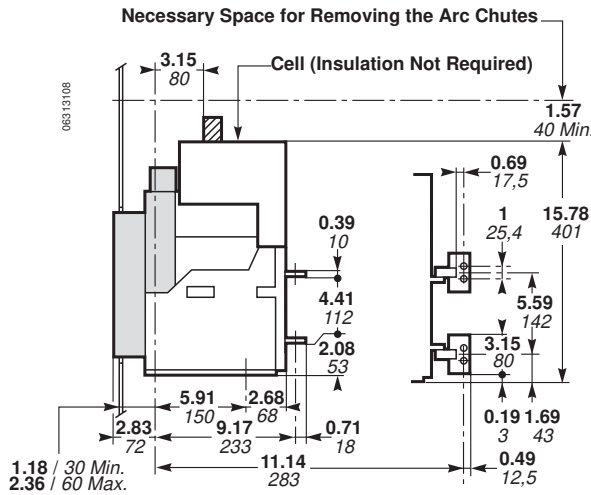
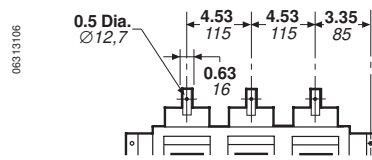
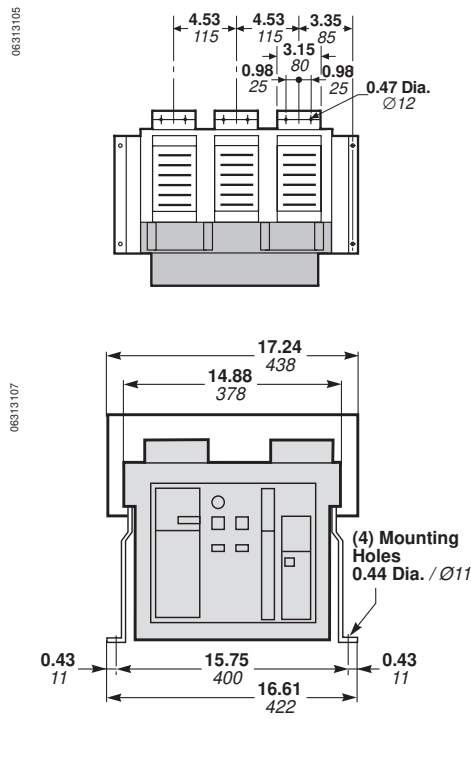

Note: Suitable for continuous operation at 100% rating in a minimum cubicle space 17.5 in. (440 mm) h. by 21 in. (530 mm) w. by 14.25 in. (360 mm) d. Ventilation is not required. Refer to shop drawing #688 378 for verification. Vertical terminals are optional for MP08–MP12 circuit breakers.

### 4-Pole

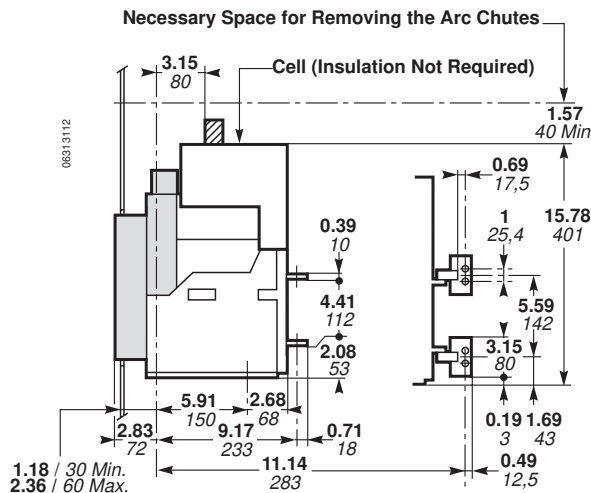
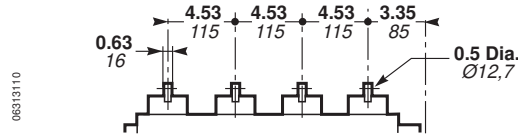
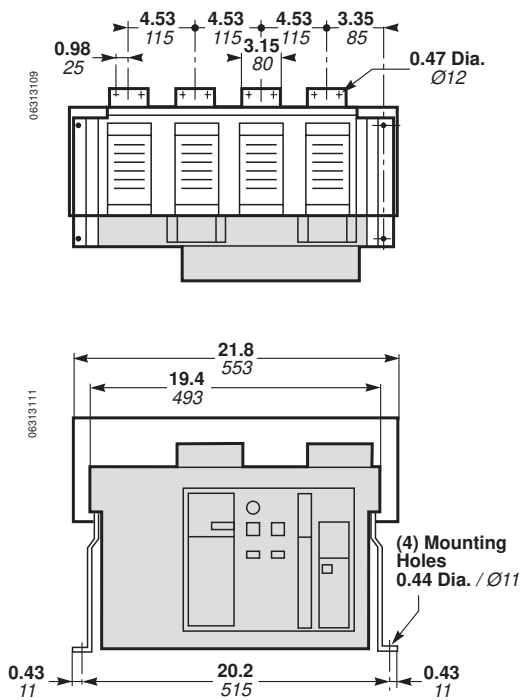

Note: Suitable for continuous operation at 100% rating in a minimum cubicle space 17.5 in. (440 mm) h. by 25.5 in. (645 mm) w. by 14.25 in. (360 mm) d. Ventilation is not required. Refer to shop drawing #691 378 for verification. Vertical terminals are optional for MP08–MP12 circuit breakers.

Dimensions: inch  
mm



# Circuit Breaker Dimensions

## MP08–MP12–MP16–MC08–MC16 Drawout Mounting

### 3-Pole

Note: Suitable for continuous operation at 100% rating in a minimum cubicle space 17.5 in. (440 mm) h. by 21 in. (530 mm) w. by 14.25 in. (360 mm) d. Ventilation is not required. Refer to shop drawing #688 378 for verification. Vertical terminals are optional for MP08–MP12–MC08 circuit breakers.

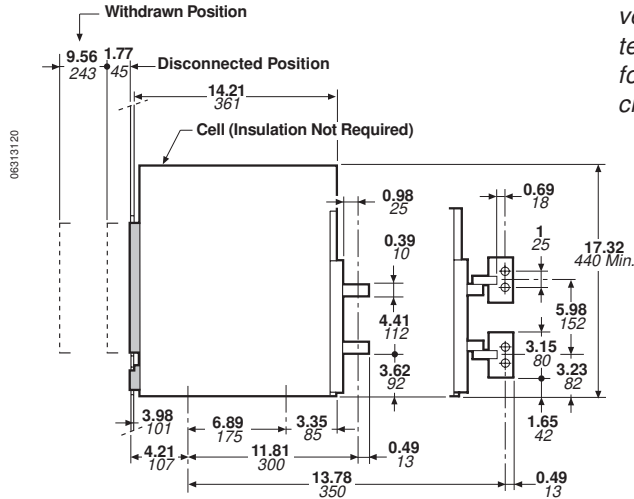
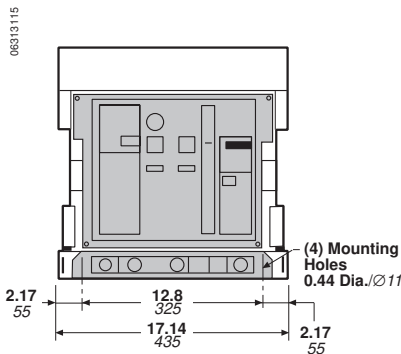
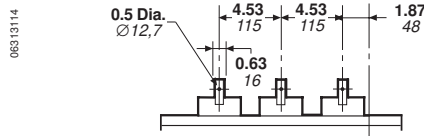
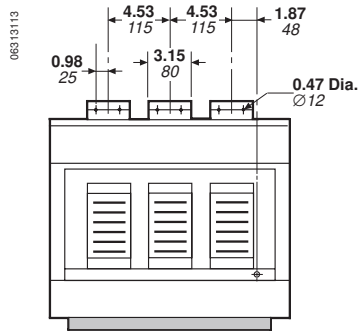

### 4-Pole

Note: Suitable for continuous operation at 100% rating in a minimum cubicle space 17.5 in. (440 mm) h. by 25.5 in. (645 mm) w. by 14.25 in. (360 mm) d. Ventilation is not required. Refer to shop drawing #691 381 for verification. Vertical terminals are optional for MP08–MP12–MC08 circuit breakers.

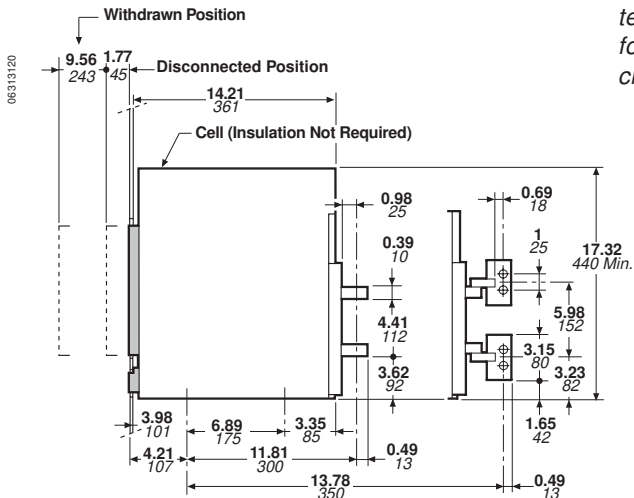
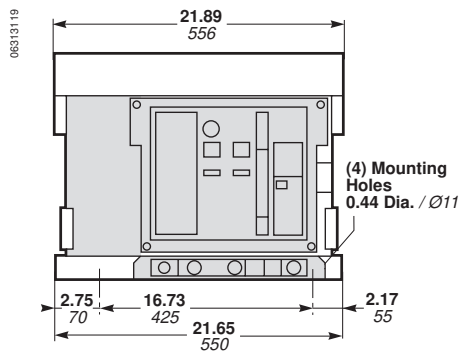
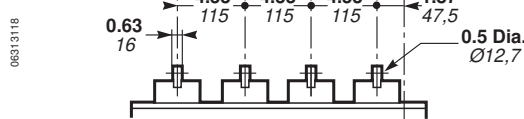
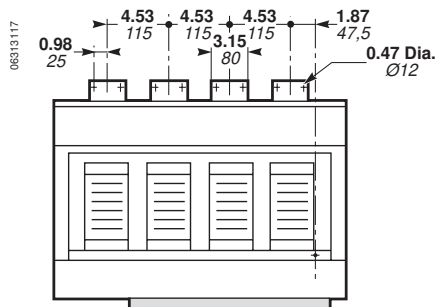

Dimensions: inch mm



# Circuit Breaker Dimensions

## MP20 Fixed Mounting

### 3-Pole

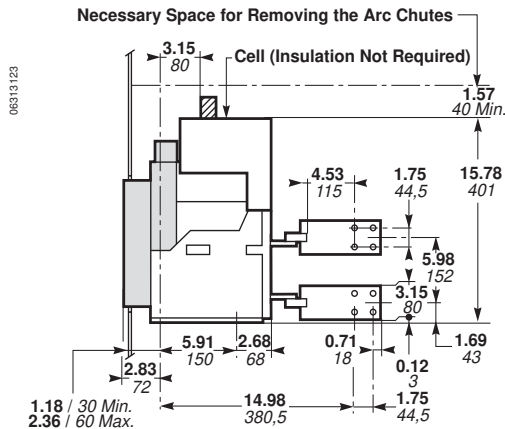
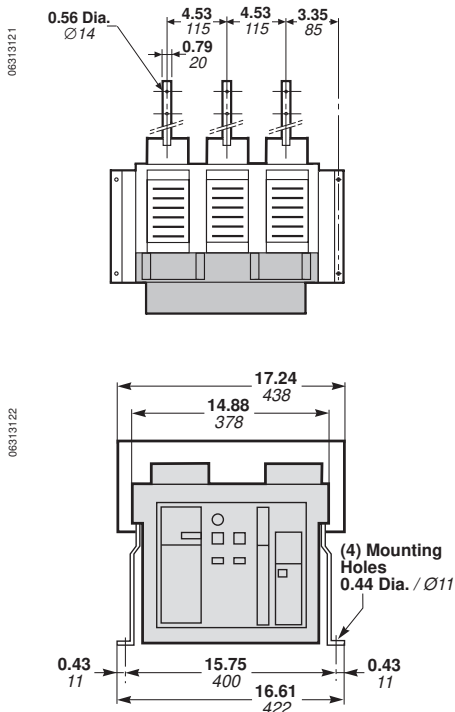

Note: Suitable for continuous operation at 100% rating in a minimum cubicle space 17.5 in. (440 mm) h. by 21 in. (530 mm) w. by 14.25 in. (360 mm) d. Ventilation is not required. Refer to shop drawing #688 379 for verification.

### 4-Pole

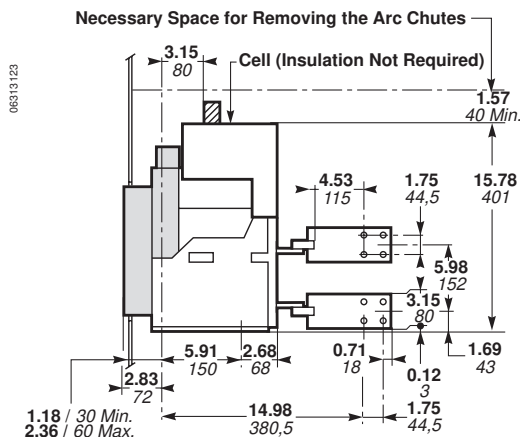
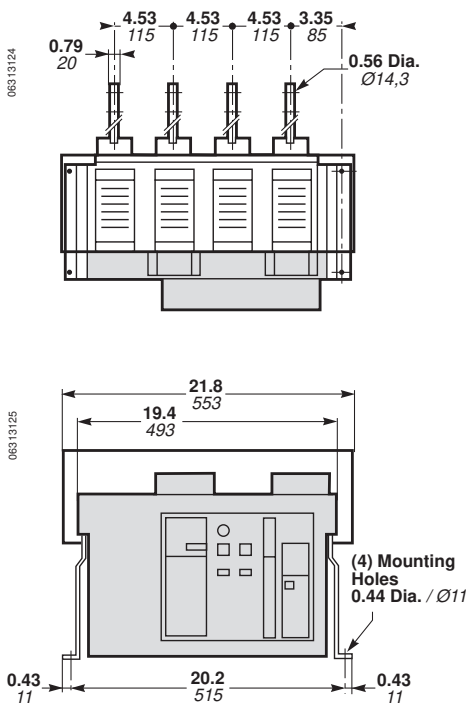

Note: Suitable for continuous operation at 100% rating in a minimum cubicle space 17.5 in. (440 mm) h. by 25.5 in. (645 mm) w. by 14.25 in. (360 mm) d. Ventilation is not required. Refer to shop drawing #691 379 for verification.

Dimensions: inch mm



# Circuit Breaker Dimensions

## MP20–MC20 Drawout Mounting

### 3-Pole

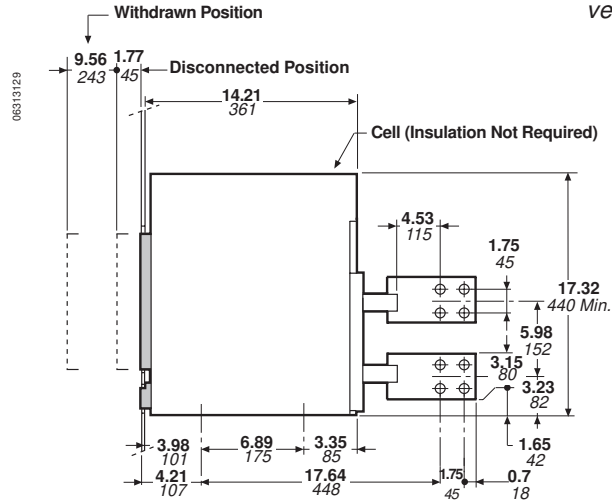
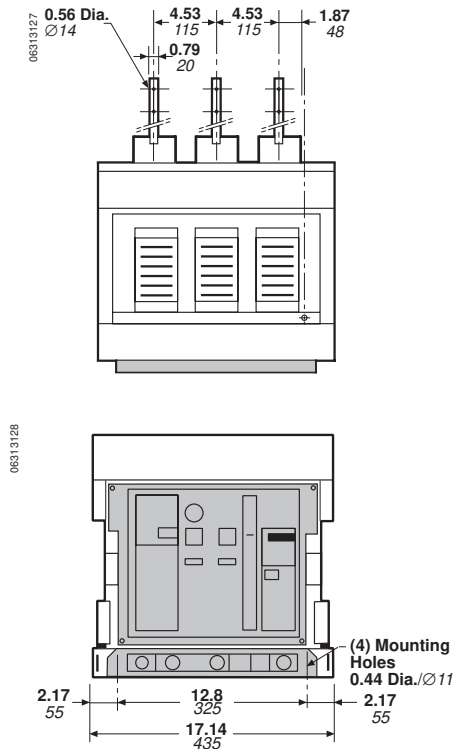

Note: Suitable for continuous operation at 100% rating in a minimum cubicle space 17.5 in. (440 mm) h. by 21 in. (530 mm) w. by 14.25 in. (360 mm) d. Ventilation is not required. Refer to shop drawing #688 379 for verification.

### 4-Pole

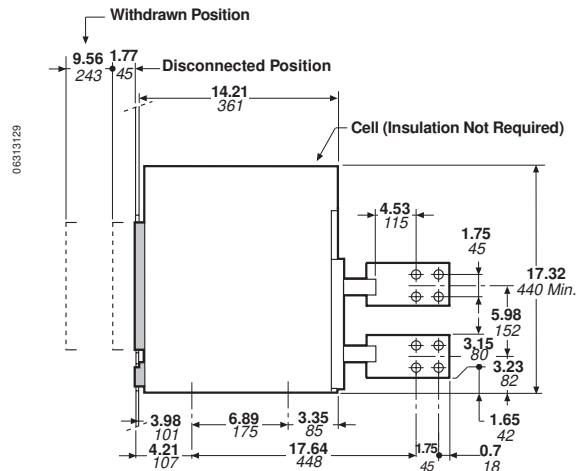
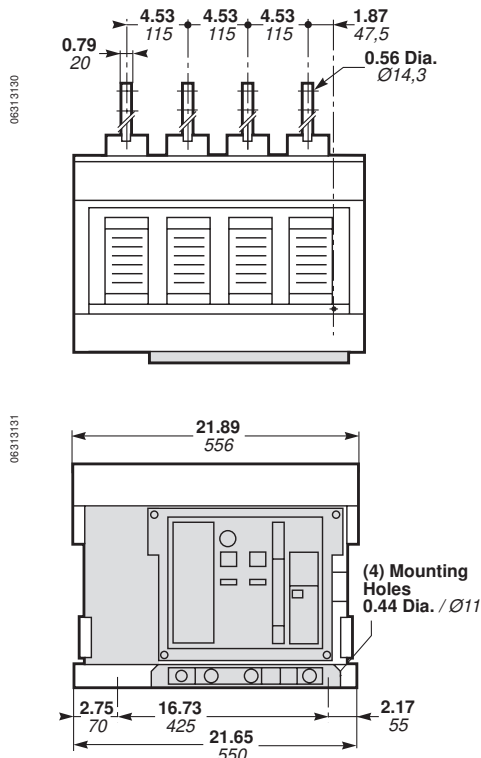

Note: Suitable for continuous operation at 100% rating in a minimum cubicle space 17.5 in. (440 mm) h. by 25.5 in. (645 mm) w. by 14.25 in. (360 mm) d. Ventilation is not required. Refer to shop drawing #691 382 for verification.

Dimensions: inch mm



# Circuit Breaker Dimensions

## MP25–MP30 Fixed Mounting

### 3-Pole

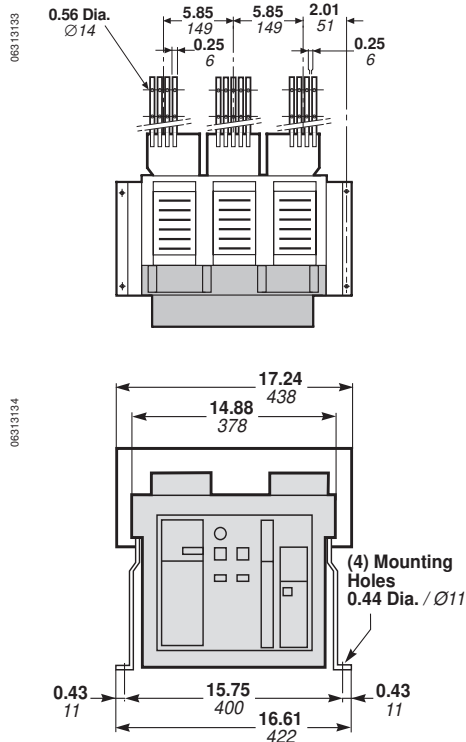

Necessary Space for Removing the Arc Chutes

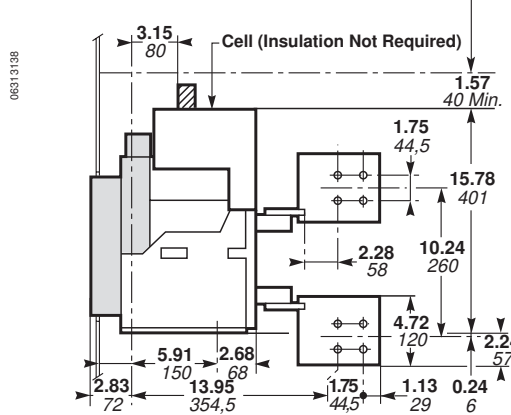

Note: Suitable for continuous operation at 100% rating in a minimum cubicle space 26 in. (660 mm) h. by 21 in. (530 mm) w. by 14.25 in. (360 mm) d. with a ventilation of 30 sq. in. (200 cm<sup>2</sup>) at top and bottom. Refer to shop drawing #688 380 for verification.

### 4-Pole

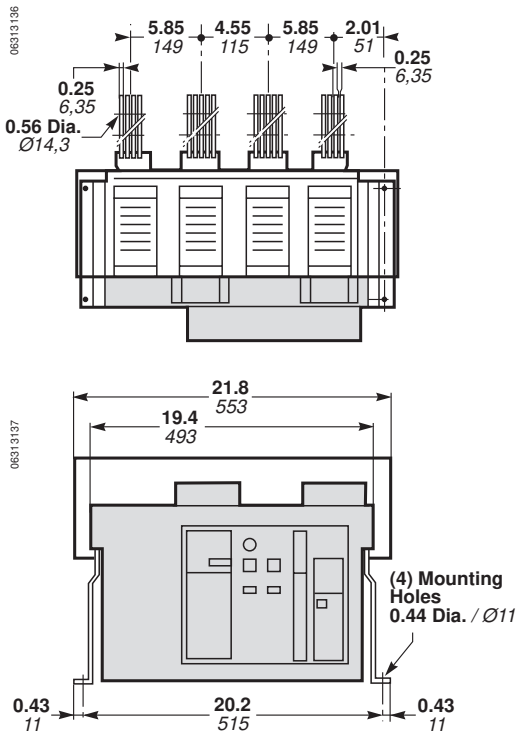

Necessary Space for Removing the Arc Chutes

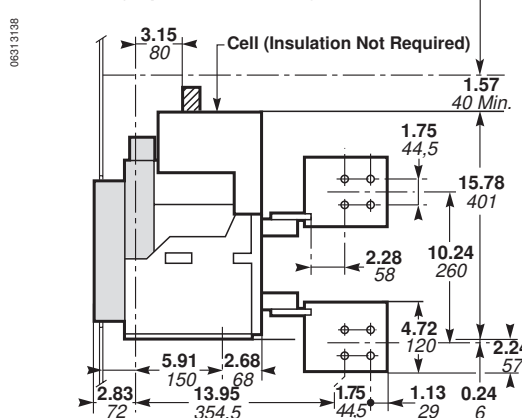

Note: Suitable for continuous operation at 100% rating in a minimum cubicle space 26 in. (660 mm) h. by 25.5 in. (645 mm) w. by 14.25 in. (360 mm) d. with a ventilation of 30 sq. in. (200 cm<sup>2</sup>) at top and bottom. Refer to shop drawing #691 380 for verification.

Dimensions: inch mm



# Circuit Breaker Dimensions

## MP25–MP30 Drawout Mounting

### 3-Pole

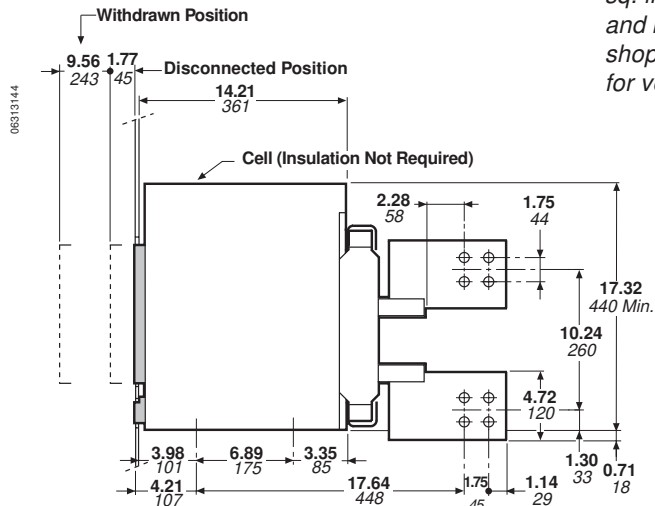
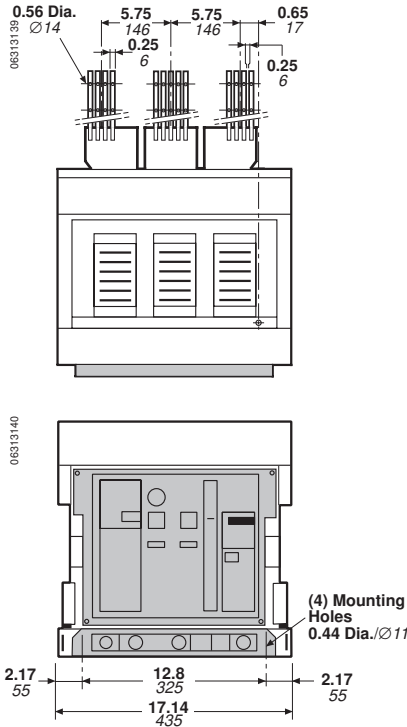

Note: Suitable for continuous operation at 100% rating in a minimum cubicle space 26 in. (660 mm) h. by 21 in. (530 mm) w. by 14.25 in. (360 mm) d. with a ventilation of 30 sq. in. (200 cm<sup>2</sup>) at top and bottom. Refer to shop drawing #688 380 for verification.

### 4-Pole

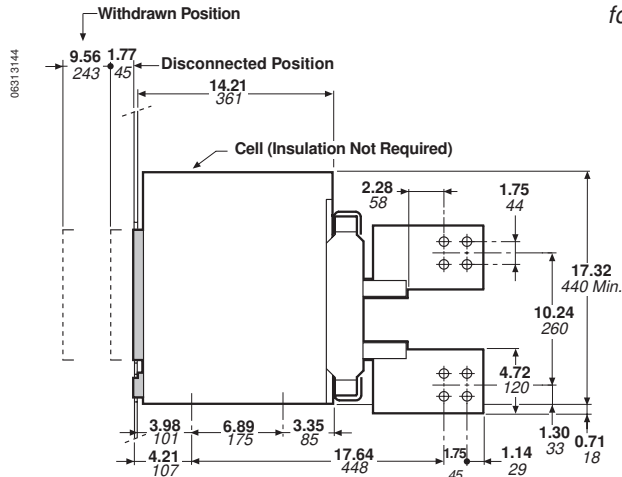
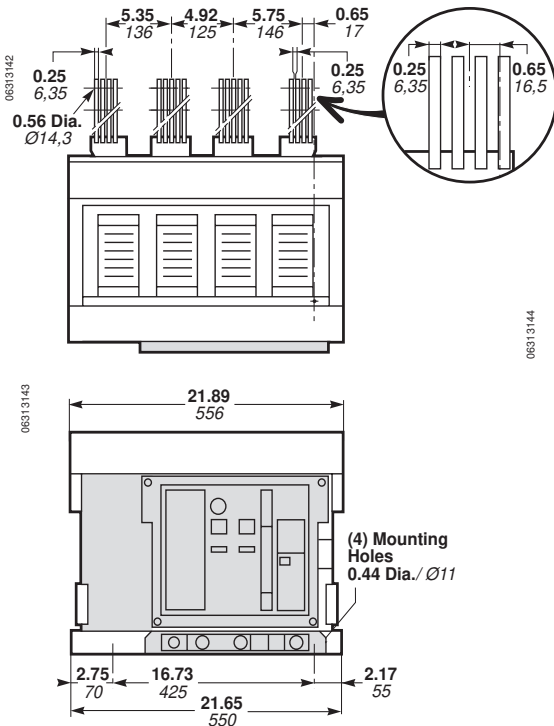

Note: Suitable for continuous operation at 100% rating in a minimum cubicle space 26 in. (660 mm) h. by 25.5 in. (645 mm) w. by 14.25 in. (360 mm) d. with a ventilation of 30 sq. in. (200 cm<sup>2</sup>) at top and bottom. Refer to shop drawing #691 380 for verification.

Dimensions: inch mm



# Circuit Breaker Dimensions

## MC32 Drawout Mounting

### 3-Pole

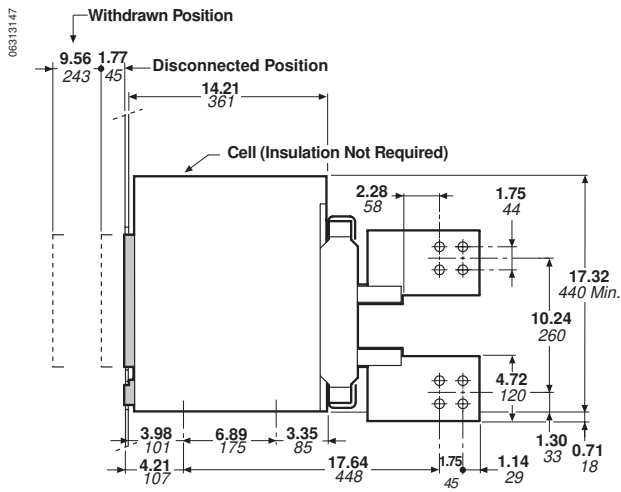
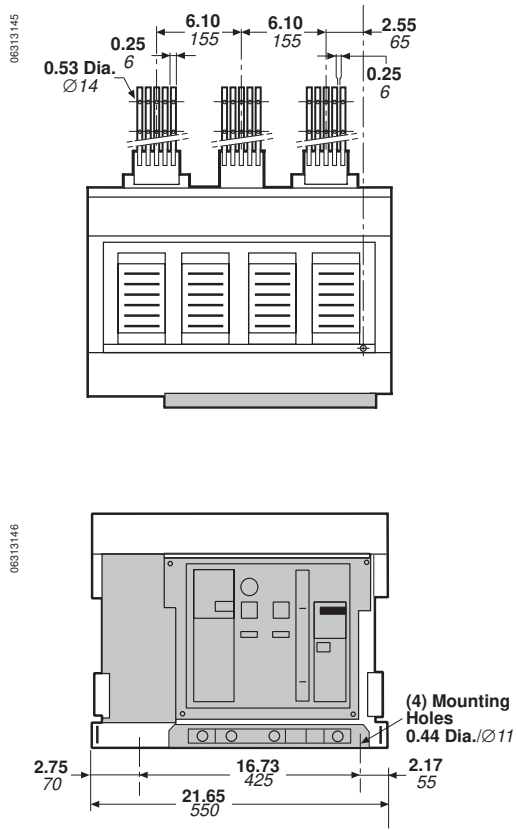

*Note: Suitable for continuous operation at 100% rating in a minimum cubicle space 22 in. (560 mm) h. by 25.25 in. (640 mm) w. by 14.25 in. (360 mm) d. with a ventilation of 30 sq. in. (200 cm<sup>2</sup>) at bottom. Refer to shop drawing #689 074 for verification.*

Dimensions: inch  
mm



# Circuit Breaker Dimensions

## MP40–MP50 Fixed Mounting

### 3-Pole

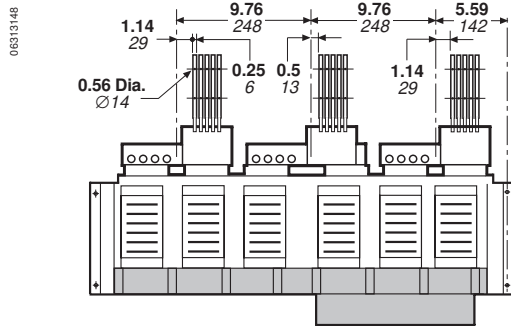

### MP40

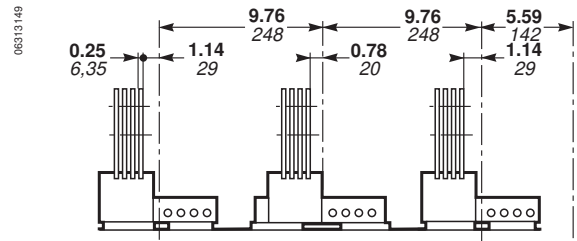

### MP50

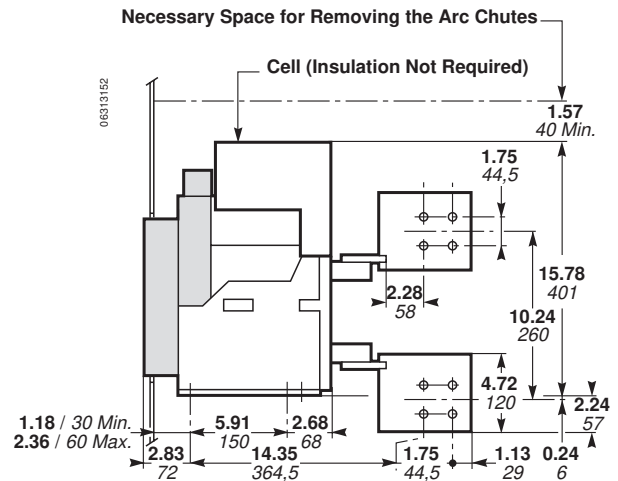
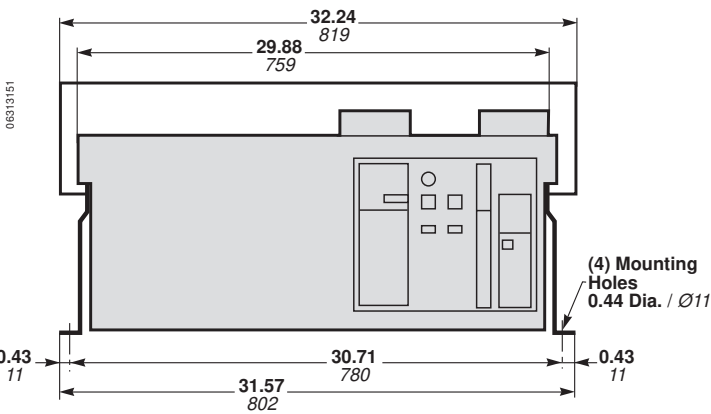
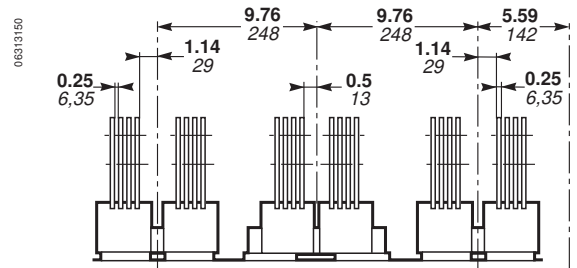

Note: Suitable for continuous operation at 100% rating in a minimum cubicle space 26 in. (660 mm) h. by 34 in. (870 mm) w. by 14.25 in. (360 mm) d. with a ventilation of 30 sq. in. (200 cm<sup>2</sup>) both at top and bottom. Refer to shop drawing #688 381 for verification.

Dimensions: inch  
mm



# Circuit Breaker Dimensions

## MP40–MP50–MC50–MC50 Drawout Mounting

### 3-Pole

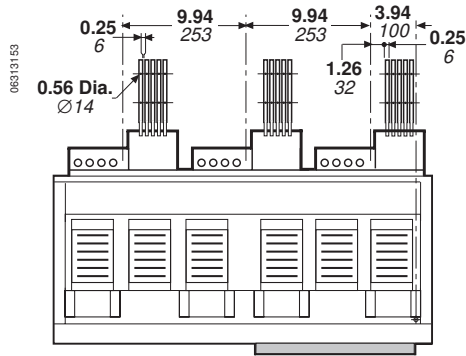

### MP40–MC50

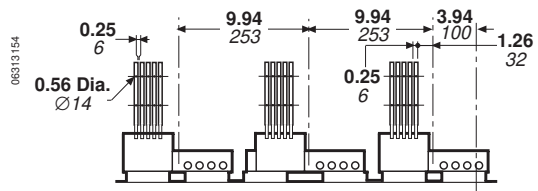

### MP50–MC50

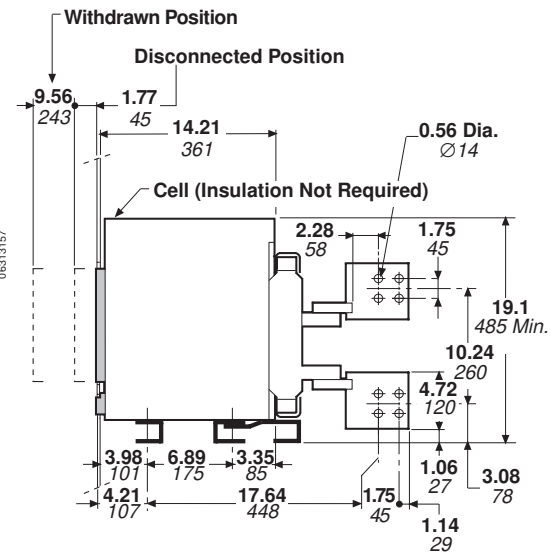
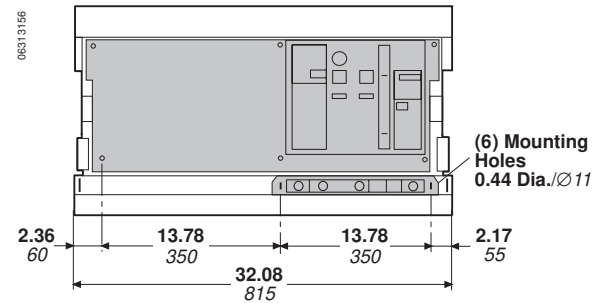
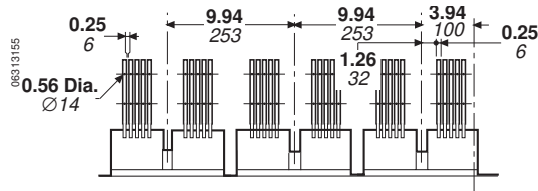

Note: Suitable for continuous operation at 100% rating in a minimum cubicle space 26 in. (660 mm) h. by 34 in. (870 mm) w. by 14.25 in. (360 mm) d. with a ventilation of 30 sq. in. (200 cm<sup>2</sup>) both at top and bottom. Refer to shop drawing #688 381 for verification.

Dimensions: inch  
mm





# Circuit Breaker Dimensions

## MP63 Drawout Mounting (Not UL Listed)

### 3-Pole

Note: Refer to shop drawing #688 382 for verification.

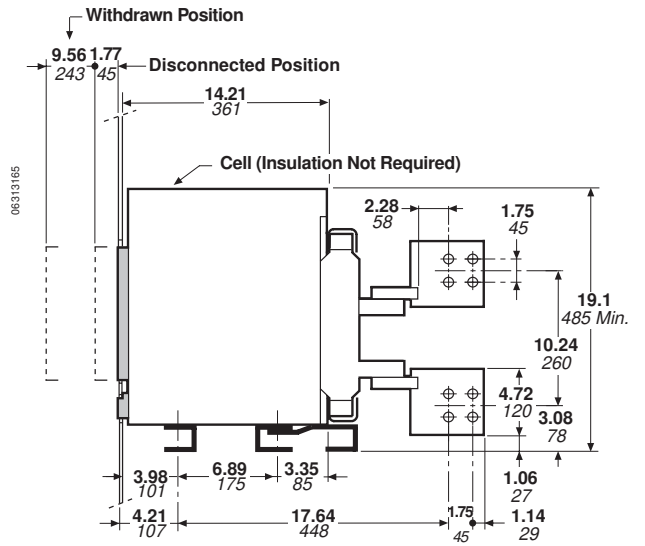
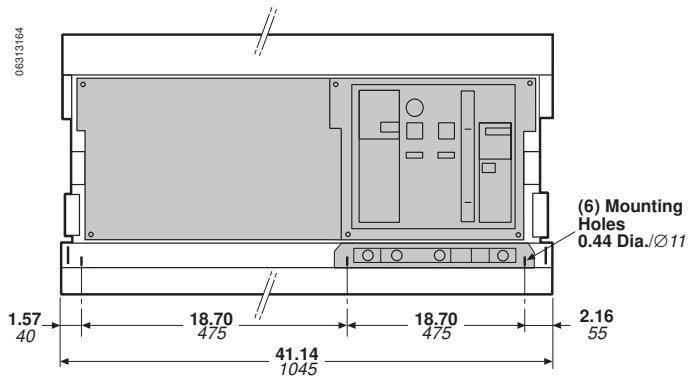
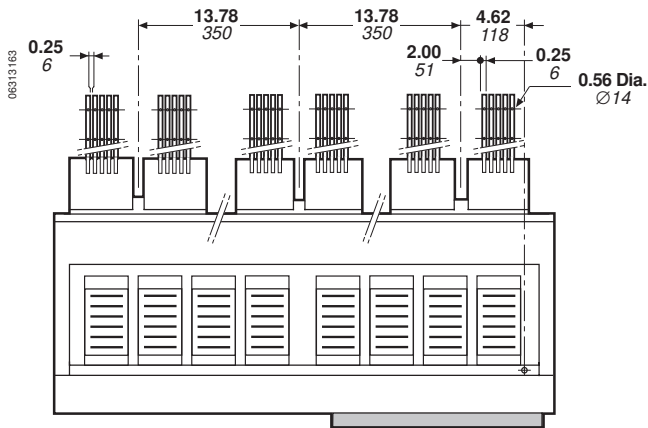

Dimensions: inch  
mm



# Circuit Breaker Dimensions

## Mechanical Interlocks for Drawout or Fixed Circuit Breakers Connecting Links for Two Stack-mounted Circuit Breakers

### Drawout Mounting

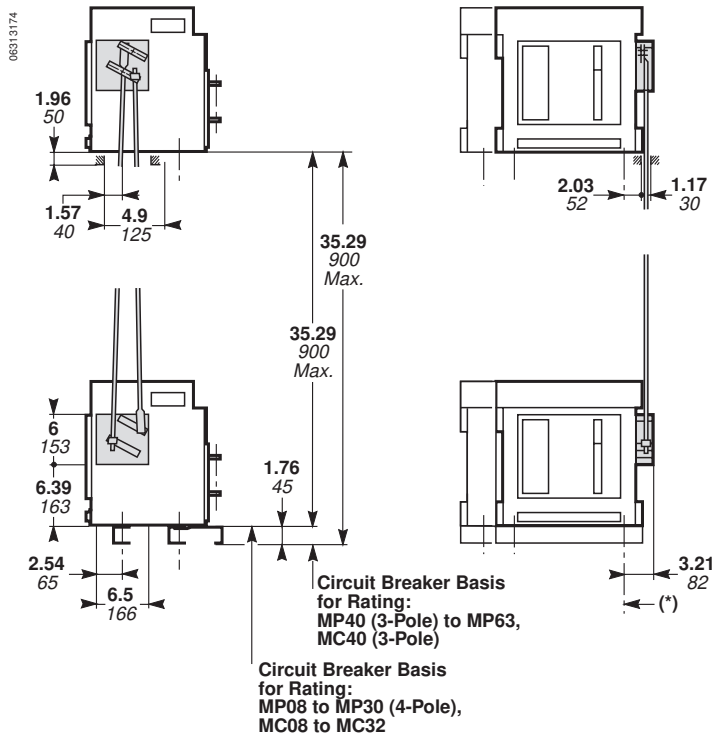

### Fixed Mounting

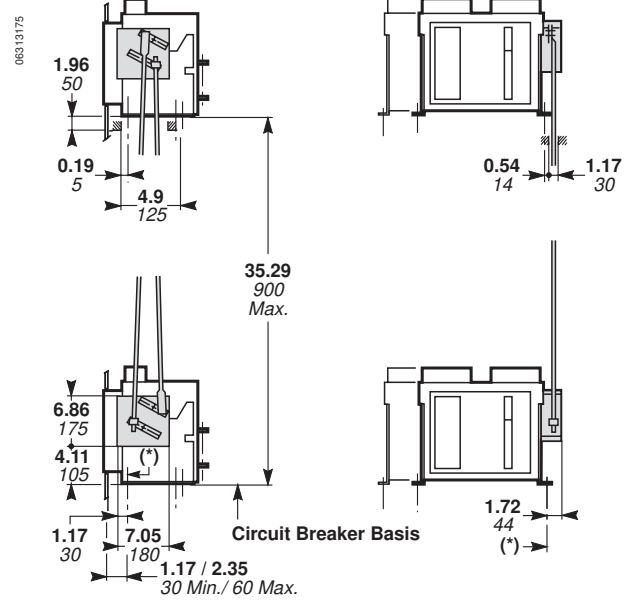

Dimensions: inch  
mm



# Circuit Breaker Dimensions

## Connecting Links for Three Stack-mounted Circuit Breakers

### Drawout Mounting

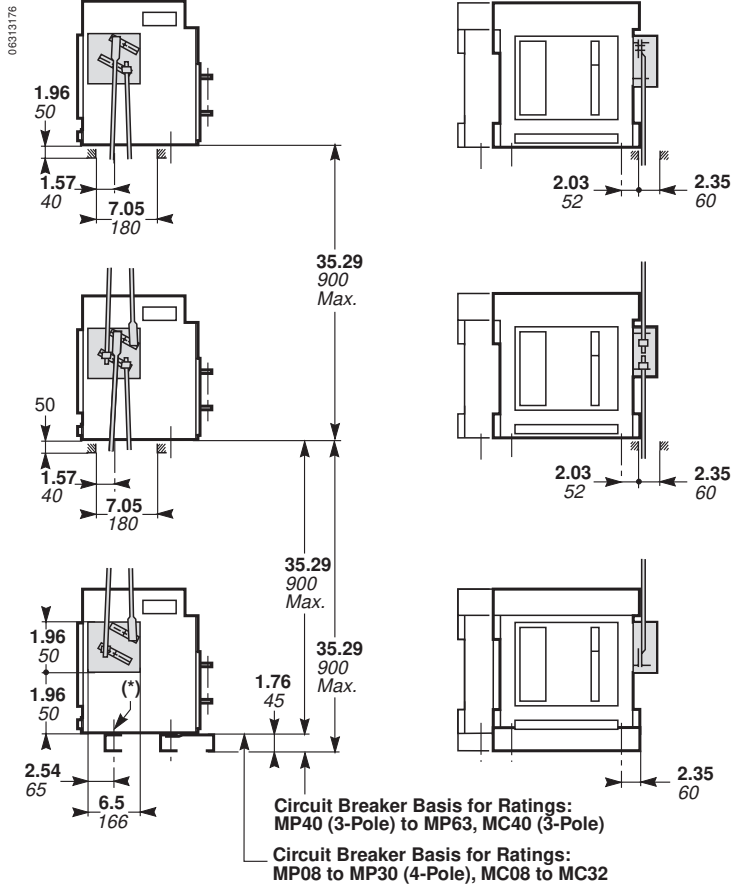

### Fixed Mounting

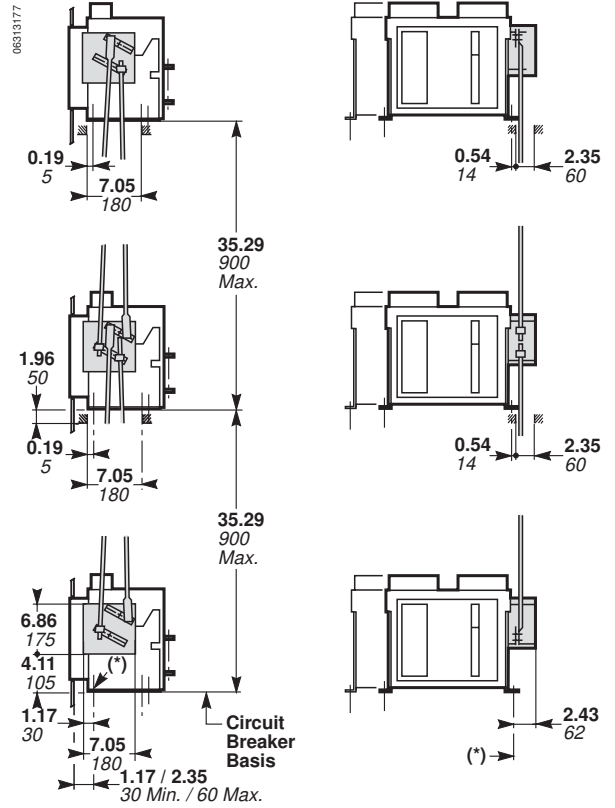

## Mechanical Interlocks for Drawout or Fixed Circuit Breakers

### Cables for Two Side-by-Side Circuit Breakers

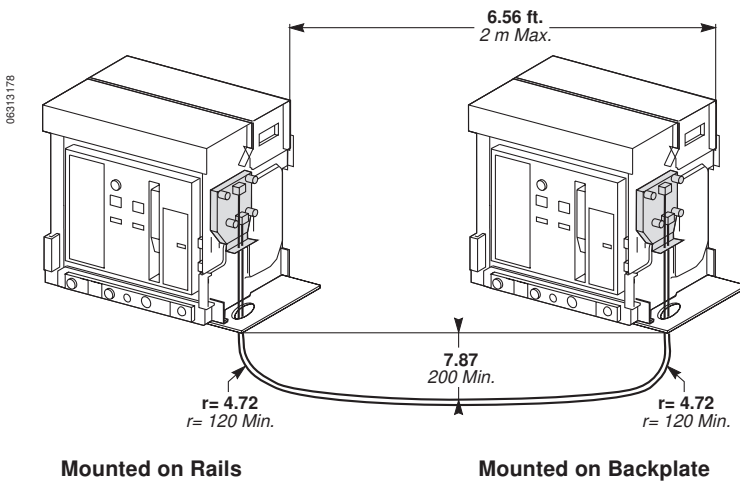

Dimensions: inch  
mm

(Except as otherwise  
indicated)



# Circuit Breaker Dimensions

## DC150 Data Concentrator

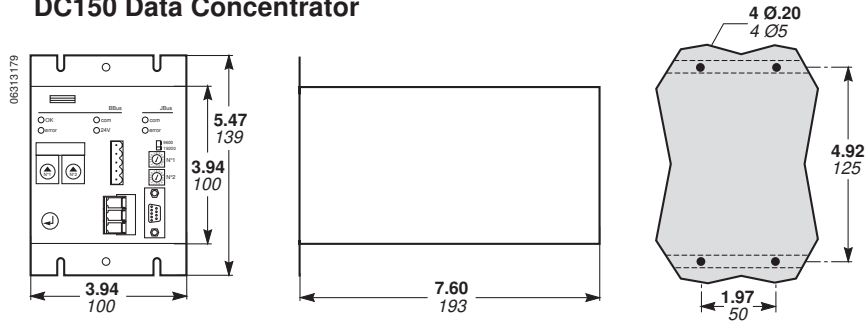

## SC150 Indication and Control Interface

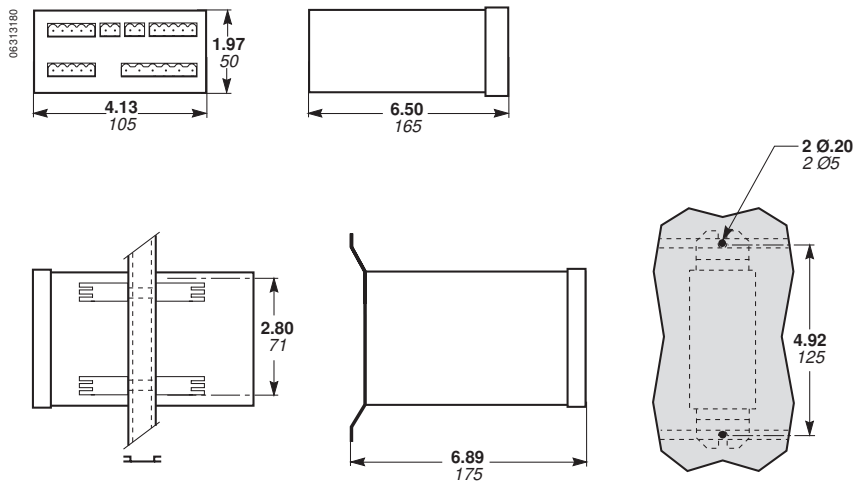

Dimensions: inch  
mm



## Routine Maintenance Guidelines

<p><b>⚠ DANGER</b></p> <p><b>HAZARD OF ELECTRICAL SHOCK, BURN OR EXPLOSION.</b></p> <p>Turn OFF all power supplying the equipment before installing or removing circuit breaker.</p> <p><b>Failure to observe these precautions will cause death, personal injury or electrical shock.</b></p>
--

<p><b>⚠ CAUTION</b></p> <p><b>HAZARD OF EQUIPMENT DAMAGE.</b></p> <p>Since circuit breakers contain factory-sealed and calibrated elements. Do not break seal. In case of malfunction, repairs must be made at a Square D factory or by an authorized company representative.</p> <p><b>Failure to observe this precaution can cause equipment damage.</b></p>
--

### Recommended Inspection Intervals

MASTERPACT circuit breakers are designed to be maintenance free (see page 64). However, all equipment with moving parts requires periodic inspection to ensure optimum performance and reliability. It is recommended that the circuit breakers be routinely inspected six months after installation, followed by an annual inspection. Intervals can vary depending on particular use and experience.

### Inspection of Circuit Breaker Terminals

- Inspect terminals; if there is discoloration due to overheating, the joint should be disassembled and the surface cleaned before reinstallation. It is essential that electrical connections are made carefully in order to prevent overheating.
- Check for terminal tightness.

### Inspection of Main Contacts

The arc chutes are easily removed to allow access to the main contacts and to the wear indicator. The wear indicator consists of a groove located within the contacts support (see page 3). When the circuit breaker is closed, this groove is entirely covered up by the moving contacts. Over time, the wear of the contacts will make the groove appear. When the groove is fully visible, replace the breaker or have an authorized service center change the contacts.

### Inspection of Clusters

Totally maintenance free, they have to be replaced only after overheating due to a defective connection or after a major fault. Inspection is advised when checking the terminal connections.

### Cleaning

Remove any dust and dirt that may have accumulated on the circuit breaker surface and terminals.

### Mechanical Checks

For long periods circuit breakers may not be required to operate on overload or short-circuit conditions. Therefore it is essential to operate the circuit breaker periodically to avoid mechanical gumming.



## Insulation Resistance Tests

When circuit breakers are subjected to severe operating conditions, an insulation resistance test may be performed as indicated in NEMA standard publication No. AB4-1991. An insulation resistance test is used to determine the quality of the insulation between phases and phase-to-ground. The resistance test is made at a dc voltage higher than the rated voltage to determine the actual resistance of the insulation. The most common method employs a "megger" type instrument. A 1000-volt instrument will provide a more reliable test because it is capable of detecting tracking on insulated surfaces. Investigate resistance values below 1 megohm. The insulation test shall be made:

- Between line and load terminals of individual poles with the circuit breaker contacts open
- Between adjacent poles and from poles to the metallic supporting structure with the circuit breaker contacts closed

This test may be made with the circuit breaker in place after the line and load conductors have been removed, or with the circuit breaker bolted to a metallic base which simulates the in-service mounting.

## Electrical Tests

These tests require equipment for pole resistance measurement and for overcurrent and instantaneous tripping in accordance with NEMA Standard publication No. AB4. They are not within the scope of normal field operation.



# Appendix

## Endurances

<b>A—Endurance Without Maintenance</b>										
MASTERPACT MP or MC	08	12	16	20	25	30 - 32	40	50	63	
Mechanical	12,500	10,000	10,000	10,000	10,000	10,000	5,000	5,000	5,000	
Electrical	480 Vac	10,000	10,000	10,000	9,000	8,000	4,000	3,000	3,000	2,000
	600 Vac	10,000	10,000	10,000	7,000	6,000	2,600	2,500	2,500	1,500
<b>B—Endurance With Service Maintenance</b>										
Electrical (480 Vac) or Mechanical										
	20,000	20,000	20,000	15,000	15,000	15,000	10,000	10,000	10,000	
<b>C—Endurance Required by Standards</b>										
Frame size	800	1200	1600	2000	2500	3000	4000	5000	6300	
UL489	Mechanical	3,500	2,000	2,000	2,000	2,000	1,500	1,500	1,500	1,500
	Electrical	500	500	500	500	500	400	400	400	400
ANSI	Mechanical	12,500	NS	4,000	4,000	NS	1,500	1,500	NS	NS
	Electrical	2,800	NS	800	800	NS	400	400	NS	NS

### Important Notice:

All endurances given are based on normal operating conditions and conventional tests:

- Closing and opening operations at rated current
- Power factor: 0.75–0.80

As actual conditions differ, use these values only as inspection guidelines and periodically check contact wear.

Under normal operating conditions of use, as determined by UL 489 or ANSI Standards (see table C) and controlled by tests, MASTERPACT circuit breakers do not require maintenance. However, these circuit breakers exceed, without maintenance and additional costs, the endurances required by standards. See tables A and C. Service maintenance by a field service representative will extend the endurance according to table B. This service can be performed on site and consists in changing contacts, arc chutes and some other parts.

### Example:

MP16 at 480 V requires no maintenance before 10,000 cycles (mechanical or electrical). Endurance may be increased after servicing at 10,000 operations.



### IEC 947-2 Interrupting Ratings

In addition to UL 489 and ANSI C37-13, MASTERPACT circuit breakers comply with the IEC 947-2 Standard as per the table below. For further information, contact a sales representative.

Type 3-Pole	Ampere Rating (A)	Interrupting Ratings UL489			IEC 947-2			
		RMS Symmetrical Amps 480 Vac	600 Vac	Short-time	440 Vac Icu	Ics	690 Vac Icu	Ics
<b>Standard Interrupting Rating</b>								
MP08 H1	800	65 kA	65 kA	50 kA	65 kA	65 kA	65 kA	65 kA
MP12 H1	1200	65 kA	65 kA	50 kA	65 kA	65 kA	65 kA	65 kA
MP16 H1	1600	65 kA	65 kA	50 kA	65 kA	65 kA	65 kA	65 kA
MP20 H1	2000	75 kA	75 kA	75 kA	75 kA	75 kA	75 kA	75 kA
MP25 H1	2500	75 kA	75 kA	75 kA	75 kA	75 kA	75 kA	75 kA
MP30 H1	3000	75 kA	75 kA	75 kA	75 kA	75 kA	75 kA	75 kA
MP40 H1	4000	100 kA	100 kA	100 kA	100 kA	100 kA	85 kA	85 kA
MP50 H1	5000	100 kA	100 kA	100 kA	100 kA	100 kA	85 kA	85 kA
MP63 H1	6300 (1)	100 kA	100 kA	100 kA	100 kA	100 kA	85 kA	85 kA
<b>High Interrupting Rating</b>								
MP08 H2	800	100 kA	65 kA	50 kA	100 kA	100 kA	85 kA	85 kA
MP12 H2	1200	100 kA	65 kA	50 kA	100 kA	100 kA	85 kA	85 kA
MP16 H2	1600	100 kA	65 kA	50 kA	100 kA	100 kA	85 kA	85 kA
MP20 H2	2000	100 kA	75 kA	75 kA	100 kA	100 kA	85 kA	85 kA
MP25 H2	2500	100 kA	75 kA	75 kA	100 kA	100 kA	85 kA	85 kA
MP30 H2	3000	100 kA	75 kA	75 kA	100 kA	100 kA	85 kA	85 kA
MP40 H2	4000	125 kA	100 kA	100 kA	150 kA	125 kA	85 kA	85 kA
MP50 H2	5000	125 kA	100 kA	100 kA	150 kA	125 kA	85 kA	85 kA
MP63 H2	6300 (1)	150 kA	100 kA	100 kA	150 kA	125 kA	85 kA	85 kA

(1) Not UL Listed.



# Appendix

## IEC 947-2 Ratings

### Auxiliary and Position Switches

Voltage (V)	Auxiliary Switch			Overcurrent Trip Switch SDE	Ready to Close Switch PF	Position Switches CE/CD/CT
	OF	O	OFSUP			
50/60 Hz	110	15				
	240	10	10	10	10	10
	380	10	6	6	5	6
	480	10	6	6		6
	600	6	3	3		3
DC	48	5	3	3	3	3
	125	3	0.5	0.5	0.3	0.5
	250	3	0.25	0.25	0.15	0.25
	500	0.5				

OF: Heavy Duty

O: Standard

OFSUP: 24 Additional

CE: Connected

CD: Disconnected

CT: Test

### Spring Charging Motor

Rated Voltage (V)			
UL 489 Listed		IEC 947-2	
60 Hz	120	50/60 Hz	100-127
	240		200-240
DC	24	DC	24-30
	48		48-60
	125		100-125

### Closing Coil

Rated Voltage (V)			
UL 489 Listed		IEC 947-2	
60 Hz	120	50/60 Hz	110-127
	240		220-250
DC	24	DC	24
	48		48
	125		125
	250		250

### Shunt Trip

Rated Voltage (V)			
UL 489 Listed		IEC 947-2	
60 Hz	120	50/60 Hz	110-127
	240		220-250
	480		440-480
DC	24	DC	24
	48		48
	125		125
	250		250

### Undervoltage Trip

Rated Voltage (V)			
UL 489 Listed		IEC 947-2	
60 Hz	120	50/60 Hz	110-127
	240		220-250
	480		440-480
DC	24	DC	24
	48		48
	125		125
	250		250





Notes





Notes





Notes



Square D Company  
PO Box 3069, 3700 Sixth St SW  
Cedar Rapids, IA 52406-3069 USA  
Field Services: 1-800-634-2003  
[www.squared.com](http://www.squared.com)

POWERLOGIC, Square D and  are registered trademarks of Square D Company.  
MASTERPACT, COMPACT and MULTI 9 are registered trademarks of Schneider Electric.  
DIGIPACT is a registered trademark of Merlin Gerin. MODBUS is a registered trademark of  
Schneider Automation. All other trademarks are the intellectual property of their respective  
companies.  
0631CT9501R11/98 November 98 Printed in USA © 1998 Square D All Rights Reserved