

RECORD ONLY SUBMITTAL PACKAGE



THIS SUBMITTAL IS BEING PREPARED FOR RECORD PURPOSES ONLY

Serving Cummins Customers

Cummins power solutions are supported by the largest and best-trained worldwide-certified sales/distributor network in the industry. This network will help you select and install the critical power solution to meet the requirements of your specific application. This same network provides experts with advanced technology to make your life easier while providing a seamless support experience.

IMPORTANT: *The critical power solution information and specifications included in this pdf can be used by the site contractor(s) and/or engineer(s) to assist with planning for and accomplishing the overall power solution installation. Please forward this document to the appropriate personnel, as necessary.*

It is the obligation of the electrical contractor and reviewing engineer to determine that the item quantities and accuracy of this submittal is correct as required for the job. Any inaccuracies or deviations must be addressed with Cummins Inc. before release to manufacturing. Any releases of material to manufacturing by the above parties constitute an acceptance of the accuracy of the submittal. Any changes after release will be viewed as a change order, subject to pricing changes. Please take the time to review this package for accuracy to prevent any after-shipment problems that could cause delay in energization.

Cummins certifies that these drawings, material lists, specification and datasheets have been checked prior to submittal and they:

- accurately depict the proposed equipment*
- provide current information to the date of the submittal and*
- present true and accurate equipment information.*

This Approval Drawing Package is submitted as our interpretation of the project requirements and/or the specifications for this job. Please note that issuance of these submittals shall not be deemed or interpreted as performance nor acceptance of your purchase order terms and conditions.

For questions or comments regarding this submittal, please contact the Cummins Project Manager listed on the title page.



**Sales and
Service**

TABLE OF CONTENTS

Section 1 - Project information

Bill of material

Section 2 - Generator specification sheets

Generator specification sheet

Generator data sheet

PowerCommand Control (PCC) specification sheet

Alternator data sheet

Sound data sheet

Cooling system data sheet

EPA certificate

Exhaust specification sheet

Prototype test summary

Section 3 - Generator accessories

Circuit breaker data sheet and information

Section 4 - Generator drawings and interconnects

Package outline drawing

AC interconnect wiring diagram

Section 5 - Startup and warranty

Pre-start up checklist

Generator warranty statement

SECTION 1

PROJECT INFORMATION



Bill of Material

| Feature Code | Description | Qty |
|----------------------------------------------------------------------------------------------------------------------------------------------------------------------------------------------------------------------------------------------------------------------------------------------------------------------------------------------------------------------------------------------------------------------------------------------------------------------------------------------------------------------------------------------------------------------------------------------------------------------------------------------------------------------------------------------------------------------------------------------|-------------------------------------------------------------------------------------------------------------------------------------------------------------------------------------------------------------------------------------------------------------------------------------------------------------------------------------------------------------------------------------------------------------------------------------------------------------------------------------------------------------------------------------------------------------------------------------------------------------------------------------------------------------------------------------------------------------------------------------------------------------------------------------------------------------------------------------------------------------------------------------------------------------------------------------------------------------------------------------------------------------------------------------------------------------------------------------------------------------------------------------------------------------------------------------------------------------------------------------------------------------------------------------------------------------------------------------------------------------------------------------------------------------------------------------------------------------|----------|
| C2000D6E C2000D6E_C2000D6E C2000D6E_L170-2 C2000D6E_L090-2 C2000D6E_A331-2 C2000D6E_R184-2 C2000D6E_R002-2 C2000D6E_E170-2 C2000D6E_E169-2 C2000D6E_L050-2 C2000D6E_H536-2 C2000D6E_KR78-2 C2000D6E_BE10-2 C2000D6E_B280-2 C2000D6E_H679-2 C2000D6E_H704-2 C2000D6E_H606-2 C2000D6E_H720-2 C2000D6E_KA08-2 C2000D6E_H678-2 C2000D6E_M683-2 C2000D6E_M701-2 C2000D6E_0431 C2000D6E_0450 C2000D6E_KB73-2 C2000D6E_KU68-2 C2000D6E_H667-2 C2000D6E_A333-2 C2000D6E_H756-2 C2000D6E_H545-2 C2000D6E_H389-2 C2000D6E_E166-2 C2000D6E_D041-2 C2000D6E_DC02-2 C2000D6E_A334-2 C2000D6E_L312-2 C2000D6E_A358-2 C2000D6E_C325-2 | C2000D6E, Diesel Genset, 60Hz, 2000kW C2000D6E, Diesel Genset, 60Hz, 2000kW EPA, Tier 2, NSPS CI Stationary Emergency Emissions Certification Listing - UL 2200 Duty Rating - Standby Power (ESP) Low Voltage 277/480V 3 Phase, Wye, 4 Wire Ambient Temperature (40C/104F) 240VAC Literature - English Display Language - English Output Terminals - NEMA 2 Hole Lug 105C Temperature Rise Alternator - 60Hz, Wye, 480V, 105C Standby Control Mounting - Front Facing PowerCommand 3.3 Controller, Paralleling Capable Analog Meters - AC Output AmpSentry™ UL Listed Protective Relay Alarm - Audible, Engine Shutdown LCD Control Display Circuit Breaker or Entrance Box - Single Manual Circuit Breaker - Left CB dual breaker type_None Circuit Breaker - None - Right Circuit Breaker or Entrance Box - Bottom Entry,Left Side Circuit Breaker - 3000A, 3P, 600/690V, UL/IEC, Left Indication-Ground Fault, Terminal Box (or) Circuit Breaker Box - Left Battery Charging Alternator Water in Fuel (WIF) sensor Low fuel pressure sensor Shutdown - Low Coolant Level Temperature independent coolant heater (208/240) Engine Air Cleaner - Normal Duty Air cleaner restriction indicator (Mechanical) Engine Starter - 24 Volt DC Motor Genset Warranty - 3 Year Base, 1000 hours Packing - None Fuel Filters - Engine, Single | 2 |

SECTION 2
GENERATOR
SPECIFICATIONS



C1750D6E C2000D6E

DIESEL GENERATOR SET SPECIFICATION SHEET

QSK50 ENGINE, 1750-2000 kWe, 60 Hz, EPA TIER 2 NSPS CERTIFIED (STATIONARY EMERGENCY)

DESCRIPTION

Cummins commercial generator sets are fully integrated power generation systems for stationary standby power and data center applications.

The Centum™ Series meets the demand for efficient and sustainable power with performance, flexibility, and commitment – for the next generation of power.

FEATURES

Cummins Heavy-Duty Engine: Rugged, four-cycle industrial diesel delivers reliable power, low emissions and fast response to load changes.

Alternator: Several alternator sizes offer selectable motor starting capability with low reactance 2/3 pitch windings, low waveform distortion with non-linear loads, fault clearing short-circuit capability and class H insulation.

ISO 8528-5 G3 Capable: Consult factory for site and configuration specific transient performance information.

HVO Fuel Compatible: Approved for use with paraffinic fuels (EN15940), including Hydrotreated Vegetable Oil (HVO), which has a very low life cycle carbon emission.

Data Center Continuous (DCC): Applicable for supplying power continuously to a constant or varying electrical load for unlimited hours in a data center application.

Uptime compliant: Meets the requirement of a Tier III and IV data center site by being rated to run for unlimited hours of operation when loaded to 'N' demand for the engine generator set.

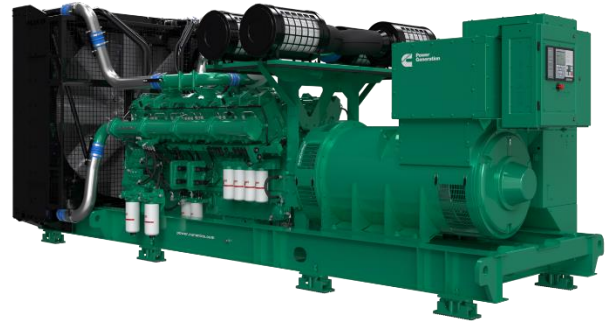

Permanent Magnet Generator (PMG): Offers enhanced motor starting and fault clearing short circuit capability.

Control System: The PowerCommand® digital control is standard equipment and provides total genset system integration including automatic remote starting/stopping, precise frequency and voltage regulation, alarm, and status message display, AmpSentry™ protective relay, output metering, auto-shutdown at fault detection and NFPA 110 Level 1 compliance.

Cooling System: High ambient (40 °C) and enhanced high ambient (50 °C), integral set-mounted radiator systems, designed and tested for rated ambient temperatures, simplifies facility design requirements for rejected heat.

NFPA: The genset accepts full rated load in a single step in accordance with NFPA 110 for Level 1 systems.

Warranty and Service: Backed by a standard three-year warranty and worldwide distributor network.

MODELS

| | Emergency Standby Power (ESP) Rating ¹ kWe (kVA) | Prime Power (PRP) Rating ^{1,2} kWe (kVA) | Data Center Continuous (DCC) Rating ^{1,2} kWe (kVA) | Data Sheet |
|----------|----------------------------------------------------------------|------------------------------------------------------|-----------------------------------------------------------------|------------|
| C1750D6E | 1750 (2188) | 1600 (2000) | 1600 (2000) | NAD-6744 |
| C2000D6E | 2000 (2500) | 1825 (2281) | 1825 (2281) | NAD-6745 |

¹ All ratings include radiator fan losses.

² Prime rating and DCC at standby power rating available subject to Cummins' site-specific assessment; contact your Cummins distributor.



cummins.com

Bulletin NAS-6746 PD00001955 Produced in U.S.A. (Rev. 06/24)
©2024 Cummins Inc.

Centum™
SERIES GENERATORS

GENERATOR SET SPECIFICATIONS

| | |
|-------------------------------------------|-----------------------------------------------------------------------------------------------------------------------------|
| Performance class | Genset models have been tested in accordance with ISO 8528-5. Consult factory for transient performance information |
| Voltage regulation, no load to full load | ± 0.5% |
| Random voltage variation | ± 1.0% |
| Frequency regulation | Isochronous |
| Random frequency variation | ± 0.25% |
| Electromagnetic compatibility performance | Emissions to EN 61000-6-2:2005 Immunity to EN 61000-6-4:2007+A1:2011 Complies with FCC PART 15 subpart B and ICES-002 |

ENGINE SPECIFICATIONS

| | |
|-----------------------------|------------------------------------------------------------------------------------------------------------------------------------------------------------------------------------|
| Bore | 159 mm (6.26 in.) |
| Stroke | 159 mm (6.26 in.) |
| Displacement | 49.8 liters (3039 in3) |
| Configuration | Four Cycle; Vee; 16 Cylinder |
| Battery capacity | 1800 amps minimum at ambient temperature of -18 °C (0 °F) |
| Battery charging alternator | 100A |
| Starting voltage | 24 volts, negative ground |
| Fuel system | Cummins YZ Modular Common Rail System (MCRS) |
| Fuel filter | Two-stage, spin-on fuel filter and water separator system. Stage 1: remote mounted, 5 µm duplex filter with two priming pumps. Stage 2: engine mounted, 3 µm triple element filter |
| Air cleaner | Dry replaceable element |
| Lube oil filter | Four spin-on, combination full flow filter and bypass filters |
| Standard cooling system | High ambient cooling system |

ALTERNATOR SPECIFICATIONS

| | |
|----------------------------------------------|------------------------------------------------|
| Design | Brushless, 4-pole, drip proof, revolving field |
| Stator | 2/3 pitch |
| Rotor | Single bearing, flexible disc |
| Insulation system | Class H |
| Standard temperature rise | 125 °C standby |
| Exciter type | Permanent Magnet Generator (PMG) |
| Phase rotation | A (U), B (V), C (W) |
| Alternator cooling | Direct drive centrifugal blower fan |
| AC waveform total harmonic distortion (THDV) | < 5% no load to full linear load |

AVAILABLE VOLTAGES (60 Hz LINE-TO-NEUTRAL / LINE-TO-LINE)³

| | | | | | |
|------------|-----------|-----------|-----------|------------|------------|
| 277/480 | 254/440 | 220/380 | 2400/4160 | 347/600 | 7976/13800 |
| 7620/13200 | 3810/6600 | 3640/6300 | 3985/6900 | 6350/11000 | 7200/12470 |

³ Additional voltages may be available; contact your Cummins distributor

GENERATOR SET OPTIONS AND ACCESSORIES⁴

Generator Set

- Oil sampling valve
 - 10A battery charger
 - **Set mounted circuit breakers up to 3200 Amps**
 - Circuit breaker aux and trip contacts
 - Anti-vibration mounts
 - Battery temperature sensor
 - IBC Certification
 - HCAI Certification
- ### Engine
- **240V thermo-statically controlled coolant heater**
 - 120/240V 500W lube oil heaters
 - Heavy duty air cleaner
 - Remote duplex fuel filter
 - Engine oil filters - full flow with bypass
 - Automatic oil make up system and monitoring
 - Engine toolkit

Control Panel

- Masterless load demand
- Multiple language support
- 120/240V 100W control anti- condensation heater

- Exhaust pyrometer
- **Ground fault indication**
- Paralleling relay package
- Shutdown alarm relay package
- Mechanical hour meter
- 6x user-configurable relays
- 8 additional I/O relays

Alternator

- **80°C/105°C /125°C/150°C rise**
- Stator winding temp sensor 2 RTDs/phase
- Bearing temp sensor RTDs
- 1-hole or 2-hole lug output terminal
- Cable entrance box set mounted top or bottom entry
- 120/240V 225W anti- condensation heater
- Generator Louvers

Exhaust System

- Industrial grade silencer
- Residential grade silencer
- Critical grade silencer

Cooling System

- Enhanced high ambient temperature (50 °C)
- Low coolant level warning

- Coolant heater

Data Center options

- Automatic oil make up system
- Closed crank ventilation system
- Oil sampling valve
- Propylene glycol coolant
- Customized testing

Miscellaneous

- Multilingual manuals
- **3-year extended warranty**
- 5-year extended warranty
- 10-year extended warranty
- Witness testing
- Virtual witness test
- Tier 4 compliant aftertreatment kits shipped loose

⁴ Some options may not be available on all models; contact your Cummins distributor.

Data Center options are available through RFQ with the Custom Applications Group and could result in additional lead-times. Please consult with the Custom Applications Group to understand feasibility



cummins.com

Bulletin NAS-6746 PD00001955 Produced in U.S.A. (Rev. 06/24)
©2024 Cummins Inc.

Centum
SERIES GENERATORS

PowerCommand® 3.3

CONTROL SYSTEM DESCRIPTION

The PowerCommand® 3.3 is an integrated, microprocessor-based, generator set control system providing voltage regulation, engine protection, alternator protection, operator interface and isochronous governing. Refer to document S-1570 for more detailed information on the control.

AmpSentry™: Includes integral AmpSentry™ protection, which provides a full range of alternator protection functions that are matched to the alternator provided.

Power Management: Control function provides battery monitoring and testing features and smart starting control system.

Advanced Control Methodology: Three phase sensing, full wave rectified voltage regulation, with a PWM output for stable operation with all load types.

Communications Interface: Control comes standard with PCCNet and Modbus interface.

Service: InPower™ PC-based service tool available for detailed diagnostics, setup, data logging and fault simulation.

Easily Upgradeable: PowerCommand® controls are designed with common control interfaces.

Reliable Design: The control system is designed for reliable operation in harsh environment.

Multi-Language Support

OPERATOR PANEL FEATURES

Operating/Display Functions

- Displays paralleling breaker status
- Provides direct control of the paralleling breaker
- 320 x 240 pixels graphic LED backlight LCD
- Auto, manual, start, stop, fault reset and lamp test/panel lamp switches
- Alpha-numeric display with pushbuttons
- LED lamps indicating genset running, remote start, not in auto, common shutdown, common warning, manual run mode, auto mode and stop

Paralleling Control Functions

- First Start Sensor™ system selects first genset to close to bus
- Phase lock loop synchronizer with voltage matching
- Sync check relay
- Isochronous kW and kVAR load sharing
- Load govern control for utility paralleling
- Extended paralleling (base load/peak shave) mode
- Digital power transfer control, for use with a breaker pair to provide open transition, closed transition, ramping closed transition, peaking and base load functions

Alternator Data

- Line-to-Neutral and Line-to-Line AC volts
- 3-phase AC current
- Frequency
- kW, kVAR, power factor kVA (three-phase and total)

Engine Data

- DC voltage
- Engine speed
- Lube oil pressure and temperature
- Coolant temperature
- Comprehensive FAE data (where applicable)



OPERATOR PANEL FEATURES (CONT.)

Other Data

- Genset model data
- Start attempts, starts, running hours, kWh
- Load profile (operating hours at #load in 5% increments)
- Fault history
- Data logging and fault simulation (requires InPower™)

STANDARD CONTROL FEATURES

Digital Governing

- Integrated digital electronic isochronous governor
- Temperature dynamic governing

Digital Voltage Regulation

- Integrated digital electronic voltage regulator
- 3-phase, 4-wire Line-to-Line sensing
- Configurable torque matching

AmpSentry™ AC Protection

- AmpSentry™ protective relay
- Over current and short circuit shutdown
- Over current warning
- Single and three phase fault regulation
- Over and under voltage shutdown
- Over and under frequency shutdown
- Overload warning with alarm contact
- Reverse power and reverse Var shutdown
- Field overload shutdown

Engine Protection

- Battery voltage monitoring, protection, and testing
- Overspeed shutdown
- Low oil pressure warning and shutdown
- High coolant temperature warning and shutdown
- Low coolant level warning or shutdown
- Fail to start (overcrank) shutdown
- Fail to crank shutdown
- Cranking lockout
- Sensor failure indication
- Full authority electronic engine protection

Control Functions

- Time delay start and cool down
- Real time clock for fault and event time stamping
- Exerciser clock and time of day start/stop
- Data logging
- Cycle cranking
- Load shed
- Configurable inputs and outputs (4)
- Remote emergency stop

Options

- Auxiliary output relays (2)



cummins.com

Bulletin NAS-6746 PD00001955 Produced in U.S.A. (Rev. 06/24)
©2024 Cummins Inc.

Centum™
SERIES GENERATORS

RATING DEFINITIONS

| Emergency Standby Power (ESP) | Prime Power (PRP) | Data Center Continuous (DCC) |
|---------------------------------------------------------------------------------------------------------------------------------------------------------------------------------------------------------------------------------------------------------------------------------------------------------------------------------------------|----------------------------------------------------------------------------------------------------------------------------------------------------------------------------------------------------------------------------------------------------------------------------------------------------------------------------------------------------------------------------------------------------------------------------------------------------------------------|-----------------------------------------------------------------------------------------------------------------------------------------------------------------------------------------------------------------------------------------------------------------------------------------------------------------------------------------------|
| Applicable for supplying power to varying electrical loads for the duration of power interruption of a reliable utility source. Emergency Standby Power (ESP) is in accordance with ISO 8528. Data shown above represents gross engine performance and capabilities as per ISO 3046-1, obtained and corrected in accordance with ISO 15550. | Prime Power for Stationary Emergency ratings apply to installations served by a reliable utility source. Applicable for supplying power to varying electrical loads for unlimited hours. Prime Power (PRP) is in accordance with ISO 8528. Ten percent overload capability is available in accordance with ISO 3046-1. Data shown above represents gross engine performance and capabilities as per ISO 3046-1, obtained and corrected in accordance with ISO 15550. | Applicable for supplying power continuously to a constant or varying electrical load for unlimited hours in a data center application. Designed to comply with Uptime Institute® Tier III and IV data center site requirements by being rated to run for unlimited hours of operation when loaded to 'N' demand for the engine generator set. |

GENERATOR SET DIMENSIONS AND WEIGHTS⁵

Refer to drawings for specific weights & dimensions

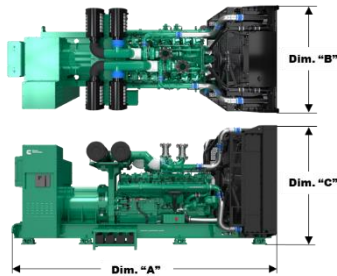

| Model Name | Dim. "A" mm (in) | Dim. "B" mm (in) | Dim. "C" mm (in) |
|-----------------|---------------------|---------------------|---------------------|
| C1750D6E | 5708 (224.7) | 2470 (97.2) | 2441 (96.1) |
| C2000D6E | | | |

| Model Name | As Shipped Cooling System Weight (Dry) kg (lb) | Installed Set Weight (Wet) kg (lb) |
|-----------------|---------------------------------------------------|---------------------------------------|
| C1750D6E | 14135 (31169) | 14512 (32001) |
| C2000D6E | | |

⁵ Do not use for installation design. Longest alternator (G-core) used for dimension "A". All weights are approximate and represent a generator set with standard features and heaviest alternator (low voltage G-core). "As Shipped Set Weight (No Cooling System)" includes weight from engine oil. "Installed Set Weight (Wet)" includes weight from engine oil and coolant. See respective model data sheet for specific model outline drawing number that contains weights of other configurations.

CODES AND STANDARDS⁶

| | | | |
|---------------------------------------------------------------------------------------------------------------------------------|------------------------------------------------------------------------------------------------------------------------------------------------------------------------------------------------------------------------|----------------------------------------------------------------------------------------------------------|--------------------------------------------------------------------------------------------------------------------------------------------------------------------------------------------------------------|
|  <p>ISO 9001 ISO 14001 ISO 45001</p> | This product was manufactured in a facility whose quality management system is certified to ISO 9001 and its Health Safety Environmental Management Systems certified to ISO 14001 and ISO 45001. |  <p>UL LISTED</p> | UL Listing to UL 2200, "Stationary Engine Generator Assemblies" is available for this genset model. The PowerCommand® control is listed to UL 508 – Category NITW7 for U.S. and Canadian usage. |
|  | The Prototype Test Support (PTS) program verifies the performance integrity of the generator set design. Cummins products bearing the PTS symbol meet the prototype test requirements of NFPA 110 for Level 1 systems. |  | Engine certified to Stationary Emergency U.S. EPA New Source Performance Standards (NSPS), 40 CFR 60 subpart IIII Tier 2 exhaust emission levels. U.S. applications must be applied per this EPA regulation. |
|  | All genset models are available as CSA certified to CSA C22.2 No. 100. |  | The generator set package is available certified for seismic application in accordance with International Building Code. |

⁶ Codes or standards compliance may not be available with all model configurations; contact your Cummins distributor.



cummins.com

Bulletin NAS-6746 PD00001955 Produced in U.S.A. (Rev. 06/24)
©2024 Cummins Inc.

Centum
SERIES GENERATORS

C2000D6E

DIESEL GENERATOR SET DATA SHEET

| | |
|---------------------------------|----------------------------------------------------------------------------------------------------------------------------------------------------------|
| MODEL: | C2000D6E |
| FREQUENCY: | 60 Hz |
| FUEL TYPE: | DIESEL |
| RATING: | 2000 kWe (2500 kVA) EMERGENCY STANDBY POWER (ESP)¹ 1825 kWe (2281 kVA) DATA CENTER CONTINUOUS (DCC)^{1,2} |
| EMISSIONS CERTIFICATION: | EPA NSPS STATIONARY EMERGENCY TIER 2 |

GENERATOR SET PUBLICATIONS

| | |
|---------------------------------------|----------------------------|
| Exhaust emission data sheet | EDS-3135 / EDS-3136 |
| Exhaust emission compliance statement | EPA-2100 / EPA-2101 |
| Sound data sheet | MSP-4178 |
| Cooling system data sheet | MCP-2257 / MCP-2258 |
| Seismic certificate of compliance | VMA-53914-01C (Revision 1) |
| Prototype test support data sheet | PTS-785 / PTS-803 |
| Genset outline drawing | A060C089 |
| Genset wiring schematic diagram | A073F079 |

ENGINE SPECIFICATIONS

| | | Emergency Standby Power (ESP) | Data Center Continuous (DCC) |
|-------------------------------------------------|----------------------|------------------------------------|------------------------------|
| Manufacturer | | Cummins Inc. | |
| Model | | QSK50 - G24 / G25 | |
| Configuration | | Four Cycle; Vee; 16 Cylinder | |
| Aspiration | | Turbocharged and Charge Air Cooled | |
| Gross engine power output | kWm (bhp) | 2204 (2956) | 1975 (2648) |
| Brake mean effective pressure at set rated load | kPa (psi) | 2951 (428) | 2641 (383) |
| Bore | mm (in) | 159 (6.26) | |
| Stroke | mm (in) | 159 (6.26) | |
| Displacement | L (in ³) | 49.8 (3039) | |
| Rated speed | rpm | 1800 | |
| Piston speed at rated speed | m/s (ft/min) | 19.1 (3756) | |
| Compression ratio | | 14.2:1 | |
| Lube oil capacity | L (US gal) | 121 (32.0) | |
| Overspeed limit | rpm | 2070 | |
| Regenerative power | kWm (hp) | 166 (223) | |

FUEL CONSUMPTION

| Rating | kWe (kVA) | 2000 (2500) | | | | 1825 (2281) | | | |
|------------------|-----------|-------------|-------|-------|-------|-------------|-------|-------|-------|
| | | 25% | 50% | 75% | 100% | 25% | 50% | 75% | 100% |
| Load | | 41.5 | 75 | 108 | 139.8 | 38 | 68 | 97 | 128.0 |
| Fuel Consumption | US gph | 157.0 | 283.9 | 408.8 | 529.1 | 143.8 | 257.4 | 367.1 | 484.5 |
| Fuel Consumption | L/h | 157.0 | 283.9 | 408.8 | 529.1 | 143.8 | 257.4 | 367.1 | 484.5 |

¹ Generator set ratings include radiator fan losses

² DCC at standby power available subject to Cummins' site-specific assessment; contact your Cummins distributor



FUEL SYSTEM

| | | Emergency Standby Power (ESP) | Data Center Continuous (DCC) |
|---------------------------------|--------------|----------------------------------|---------------------------------|
| Maximum fuel flow | L/h (US gph) | 958 (253) | |
| Maximum fuel inlet restriction | kPa (inHg) | 40 (11.8) | |
| Maximum fuel inlet temperature | °C (°F) | 70 (158) | |
| Maximum fuel return temperature | °C (°F) | 129 (264) | |

AIR SYSTEM

| | | | |
|------------------------------------------------|----------------------------|--------------|--------------|
| Combustion air flow (at set rated load) | m ³ /min (scfm) | 159.7 (5639) | 156.3 (5521) |
| Maximum air cleaner restriction (dirty filter) | kPa (inH ₂ O) | 3.7 (15) | |
| Alternator cooling air flow | m ³ /min (scfm) | 222 (7850) | |

EXHAUST SYSTEM

| | | | |
|-----------------------------------------|---------------------------|-------------|-------------|
| Exhaust flow (at set rated load) | m ³ /min (cfm) | 436 (15388) | 415 (14654) |
| Exhaust temperature (at set rated load) | °C (°F) | 535 (996) | 512 (954) |
| Maximum back pressure | kPa (inH ₂ O) | 6.7 (26.9) | |

COOLING SYSTEM (SET MOUNTED) – HIGH AMBIENT

| | | | |
|-----------------------------------------------|----------------------------|--------------|------------|
| Engine model | | QSK50 - G24 | |
| Ambient design (limiting ambient temp.) | °C (°F) | 40 (104) | |
| Fan load | kWm (hp) | 89.5 (120) | |
| Coolant capacity (engine + radiator) | L (US gal) | 140 (37) | |
| Cooling system air flow (at max. restriction) | m ³ /min (acfm) | 2073 (73210) | |
| Total heat rejection to radiator | MJ/min (Btu/min) | 88 (83282) | 80 (76207) |
| Total heat radiated to room | MJ/min (Btu/min) | 7.0 (6675) | 5.5 (5237) |
| Nominal air flow static restriction | kPa (inH ₂ O) | 0.12 (0.5) | |
| Maximum fuel return line restriction | kPa (in Hg) | 34.9 (10.3) | |

COOLING SYSTEM (SET MOUNTED) – ENHANCED HIGH AMBIENT

| | | | |
|-----------------------------------------------|----------------------------|--------------|------------|
| Engine model | | QSK50 - G25 | |
| Ambient design (limiting ambient temp.) | °C (°F) | 50.0 (122) | |
| Fan load | kWm (hp) | 105.9 (142) | |
| Coolant capacity (engine + radiator) | L (US gal) | 140 (37) | |
| Cooling system air flow (at max. restriction) | m ³ /min (acfm) | 2421 (85483) | |
| Total heat rejection to radiator | MJ/min (Btu/min) | 88 (83282) | 80 (76207) |
| Total heat radiated to room | MJ/min (Btu/min) | 7.6 (7192) | 6.4 (6026) |
| Nominal air flow static restriction | kPa (inH ₂ O) | 0.12 (0.5) | |
| Maximum fuel return line restriction | kPa (in Hg) | 34.9 (10.3) | |

GENERATOR SET WEIGHTS³

| | | As Shipped Cooling System Weight (Dry) | Installed Set Weight (Wet) |
|----------|---------|-------------------------------------------|-------------------------------|
| C2000D6E | kg (lb) | 14135 (31169) | 14512 (32001) |

³ All weights are approximate and represent a generator set with standard features and heaviest alternator (low voltage G-core). "As Shipped Set Weight (No Cooling System)" includes weight from engine oil. "Installed Set Weight (Wet)" includes weight from engine oil and coolant. See respective model data sheet for specific model outline drawing number that contains weights of other configurations.



GENERATOR SET DERATING FACTORS⁴

| | |
|--------------------------------------|------------------------------------------------------------------------------------------------------------------------------------------------------------------------------------------------------------------------------------------------------------------------------------------------------------------------------------------------------------------------------------------------------------------------------------------------------------------------------------------------------------------------------------------------------------------------------|
| Emergency Standby Power (ESP) | <p>High Ambient Cooling System: Full engine power available up to 400 m (1312 ft) at ambient temperature up to 40°C (104°F). From 400 m (1312 ft) to 2000 m (6562 ft) derates at 3% per 305 m (1000 ft). For temperature above 40°C engine derates at 10% per 10°C (18°F).</p> <p>Enhanced High Ambient Cooling System: Full engine power available at Sea level at ambient temperature up to 50°C (122°F). From 0 m (0 ft) to 2000 m (6562 ft) derates at 3.3% per 305 m (1000 ft). For temperature above 50°C engine derates at 3% per 10°C (18°F).</p> |
| Data Center Continuous (DCC) | <p>High Ambient Cooling System: Full engine power available up to 400 m (1312 ft) at ambient temperature up to 40°C (104°F). From 400 m (1312 ft) to 2000 m (6562 ft) derates at 2.8% per 305 m (1000 ft). For temperature above 40°C engine derates at 9.2% per 10°C (18°F).</p> <p>Enhanced High Ambient Cooling System: Full engine power available at Sea level at ambient temperature up to 50°C (122°F). From 0 m (0 ft) to 2000 m (6562 ft) derates at 3.1% per 305 m (1000 ft). For temperature above 50°C engine derates at 2.6% per 10°C (18°F).</p> |

⁴ Note: Ambient operating temperature is defined as the air temperature measured at the room (or enclosure) inlet, assuming a temperature rise of 3 °C to the turbocharger compressor inlet.

RATING DEFINITIONS

| Emergency Standby Power (ESP) | Data Center Continuous (DCC) |
|----------------------------------------------------------------------------------------------------------------------------------------------------------------------------------------------------------------------------------------------------------------------------------------------------------------------------------------------------|------------------------------------------------------------------------------------------------------------------------------------------------------------------------------------------------------------------------------------------------------------------------------------------------------------------------------------|
| <p>Applicable for supplying power to varying electrical loads for the duration of power interruption of a reliable utility source. Emergency Standby Power (ESP) is in accordance with ISO 8528. Data shown above represents gross engine performance and capabilities as per ISO 3046-1, obtained and corrected in accordance with ISO 15550.</p> | <p>Applicable for supplying power continuously to a constant or varying electrical load for unlimited hours in a data center application. Designed to comply with Tier III and IV data center site requirements by being rated to run for unlimited hours of operation when loaded to 'N' demand for the engine generator set.</p> |

FORMULAS

| Calculating Power Factor | Calculating Full Load Current (Three Phase AC Output) | Calculating Full Load Current (Single Phase AC Output) |
|-----------------------------------------------------------------------------------------------------------------------------------------------------------------------------------------|-----------------------------------------------------------------------------------------------------------------|---------------------------------------------------------------------------------|
| $\cos \theta = \frac{\text{Active (True, Real) Power}}{\text{Apparent Power}} = \frac{P_{(kW)}}{ S _{(kVA)}}$ <p style="text-align: center;">Power Factor = 0.8 (industry standard)</p> | $I = \frac{ S _{(kVA)}}{\sqrt{3} \times V} = \frac{1000 \times P_{(kW)}}{\sqrt{3} \times V \times \cos \theta}$ | $I = \frac{ S _{(kVA)}}{V} = \frac{1000 \times P_{(kW)}}{V \times \cos \theta}$ |





PowerCommand® 3.3 Generator Set Digital Integrated Control System



Bargraph Optional

Introduction

The PowerCommand® 3.3 control system is a microprocessor-based generator set monitoring, metering, and control system, which is comprised of PowerCommand® Control 3300 and the Human Machine Interface 320. PCC3300 supports multiple operation modes including:

- Standalone,
- Synchronization only,
- Isolated bus paralleling,
- Utility single generator set paralleling,
- Utility multiple generator set paralleling,
- Utility single generator set paralleling with power transfer control (automatic mains failure),
- Isolated bus paralleling with Masterless Load Demand

PowerCommand® Control 3300 is designed to meet the exacting demands of the harsh and diverse environments of today's typical power generation applications for Full Authority Electronic or Hydromechanical engine power generator sets.

Offering enhanced reliability and performance over more conventional generator set controls via the integration of all generator control functions into a single system, PCC3300 is your Power of One generator set control solution.

Benefits and Features

- 320 x 240 pixels graphical LED backlit LCD
- Multiple languages supported
- AmpSentry™ protection provides industry-leading generator overcurrent protection
- Digital Power Transfer Control (Automatic Mains Failure) provides load transfer operation in open transition, closed transition, or soft (ramping) transfer modes

- Extended Paralleling (Peak Shave/Base Load) regulates the genset real and reactive power output while paralleled to the utility. Power can be regulated at either the genset or utility bus monitoring point
- Digital frequency synchronization and voltage matching
- Isochronous Load Sharing
- Droop kW and kVAr control
- Real time clock for fault and event time stamping
- Exerciser clock and time of day start/stop initiate a test with or without load, or a Base Load or Peak Shave session
- Digital automatic voltage regulation is provided using three phase sensing and full wave FET type regulator, which is compatible with either shunt or PMG excited systems with a standard AUX103 AVR or an option for a more powerful high-current field drive capability AUX106 AVR
- Digital engine speed governing is provided on applicable platforms
- Generator set monitoring (including metering) and protection with PCC3300 measuring voltage, current, kW and kVAr offering a measurement accuracy of 1%
- Utility / AC Bus metering and protection with PCC3300 voltage, current, kW and kVAr offering a measurement accuracy of 1%
- 12 V (DC) and 24 V (DC) battery operation
- RS-485 Modbus® interface for interconnecting to customer equipment
- Warranty and service – Cummins Power Generation offers a comprehensive warranty and worldwide distributor service network
- Global regulatory certification and compliance: PCC3300 is suitable for use on gensets that are designed, manufactured, tested and certified to relevant UL, NFPA, ISO, IEC, Mil Std., UKCA, and CE standards

PowerCommand® Generator Set Digital Control System PCC 3300



Introduction

PCC3300 is an industry-leading digital generator set control suitable for usage on a wide range of diesel and lean burn natural gas generator sets in both standalone as well as paralleling applications.

PowerCommand® is compatible with either shunt or PMG excitation, and is suitable for usage with reconnectable or non-reconnectable generators. Configuration for any frequency, voltage and power connection from 120 V (AC) to 600 V (AC) line-to-line or 601 V (AC) to 45k V (AC) with an external PT is supported. The PCC3300 derives its own power from the generator set starting batteries and functions over a voltage range of 8 V (DC) to 30 V (DC).

Features

- PCC3300 supports configurable control features via software download using InPower PC-compatible software
- 12 V (DC) and 24 V (DC) battery operation
- Digital automatic voltage regulation is provided using three phase sensing and full wave FET type regulator, which is compatible with either shunt or PMG excited systems with a standard AUX103 AVR or an option for a more powerful high-current field drive capability AUX106 AVR
- Digital engine speed governing on applicable platform is provided, which is capable of providing isochronous frequency regulation
- Full authority J1939 CANBus® prime mover communications and control is provided for platforms with an Engine Control Module (ECM)
- AmpSentry™ protection provides industry-leading alternator overcurrent protection:
 - Time-based generator protection applicable to both line-to-line and line-to-neutral, that can detect an unbalanced fault condition and swiftly react appropriately. Balanced faults can also be detected by AmpSentry and appropriate acted upon.
 - Reduces the risk of Arc Flash due to thermal overload or electrical faults by inverse time protection
- Generator set monitoring offers status information for all critical prime mover and generator functions
- AC and DC digital generator set metering is provided. AC measurements are configurable for single or three phase sensing with PCC3300 measuring voltage, current, kW and kVAr offering a measurement accuracy of 1%
- Battery monitoring system continually monitors the battery output and warns of the potential occurrence of a weak battery condition
- Relay drivers for prime mover starter, fuel shutoff (FSO), glow plug/spark ignition power and switched B+ applications are provided
- Integrated generator set protection is offered to protect the prime mover and generator
- Real time clock for fault and event time stamping
- Exerciser clock and time of day start/stop initiate a test with or without load, or a Base Load or Peak Shave session
- Digital Power Transfer Control (Automatic Mains Failure) provides load transfer operation in open transition, closed transition, or soft (ramping) transfer modes
- Extended Paralleling (Peak Shave/Base Load) regulates the genset real and reactive power output while paralleled to the utility. Power can be regulated at either the genset or utility bus monitoring point
- Digital frequency synchronization and voltage matching
- Isochronous Load Sharing
- Droop kW and kVAr Control
- The synchronization check function provides adjustments for phase angle window, voltage window, frequency window and time delay
- Utility / AC Bus metering and protection with PCC3300 voltage, current, kW and kVAr offering a measurement accuracy of 1%
- Advanced serviceability is offered via InPower™, a PC-based software service tool
- PCC3300 is designed for reliable operation in harsh environments with the unit itself being a fully encapsulated module
- RS-485 ModBus interface for interconnecting to customer equipment
- Native on PCC3300: Four discrete inputs, two dry contact relay outputs and two low-side driver outputs are provided and are all configurable.
 - Optional extra PCC3300 input and output capability available via AUX101
- Warranty and service – Cummins Power Generation offers a comprehensive warranty and worldwide distributor service network
- Global regulatory certification and compliance: PCC3300 is suitable for use on gensets that are designed, manufactured, tested and certified to relevant UL, NFPA, ISO, IEC, Mil Std., UKCA and CE standards

Base Control Functions

HMI capability

Options: Local and remote HMI320 options are available

Operator adjustments: The HMI320 includes provisions for many set up and adjustment functions.

Genset hardware data: Access to the control and software part number, genset rating in kVA and genset model number is provided from the HMI320 or InPower.

Data logs: Information concerning all of the following parameters is periodically logged and available for viewing; engine run time, controller on time, number of start attempts, total kilowatt hours, and load profile. (Control logs data indicating the operating hours at percent of rated kW load, in 5% increments. The data is presented on the operation panel based on total operating hours on the generator.)

Fault history: Provides a record of the most recent fault conditions with control date and time stamp. Up to 32 events are stored in the control non-volatile memory.

Alternator data

- Voltage (single or three phase line-to-line and line-to-neutral)
- Current (single or three phase)
- kW, kVAR, Power Factor, kVA (three phase and total)
- Frequency

For Lean Burn Natural Gas Engine applications:

- Alternator heater status
- Alternator winding temperature (per phase) as well as alternator drive end and non-drive end bearing

Utility/AC bus data

- Voltage (three phase line-to-line and line-to-neutral)
- Current (three phase and total)
- kW, kVAR, Power Factor, kVA (three phase and total)
- Frequency

AmpSentry: 3x current regulation for downstream tripping/motor inrush management. Thermal damage curve (3-phase short) or fixed timer (2 sec for 1-Phase Short or 5 sec for 2-Phase short).

Engine data

- Starting battery voltage
- Engine speed
- Engine temperature
- Engine oil pressure
- Engine oil temperature
- Intake manifold temperature
- Coolant temperature
- Comprehensive Full Authority Engine (FAE) data (where applicable)

Lean Burn Natural Gas (LBNG) application parameters include:

- Safety shutoff valve status
- Valve proving status
- Downstream gas pressure
- Gas inlet pressure
- Gas mass flow rate
- Control valve position
- Gas outlet pressure
- Manifold pressure and temperature
- Throttle position
- Compressor outlet pressure
- Turbo speed
- Compressor bypass position
- Cylinder configuration (e.g., drive end and non-drive end configurations)
- Coolant pressure 1 and 2 as well as coolant temperature 1 and 2 for both HT/LT respectively
- Exhaust port temperature (up to 18 cylinders)
- Pre-filter oil pressure
- Exhaust back pressure
- Parent ECM internal temperature and isolated battery voltage
- Speed bias
- Child ECM internal temperature and isolated battery voltage
- Knock level, spark advance, and knock count (for up to 18 cylinders)
- Auxiliary supply disconnect status
- Engine heater status
- Coolant circulating pump status
- Lube oil priming pump status
- Lube oil status
- Oil heater status
- Derate authorization status
- Start system status
- Ventilator fan status
- Ventilation louvre status
- Radiator fan status
- DC PSU status
- Start inhibit/enable status and setup

Service adjustments – The HMI320 includes provisions for adjustment and calibration of genset control functions. Adjustments are protected by a password. Functions include:

- Engine speed governor adjustments
- Voltage regulation adjustments
- Cycle cranking
- Configurable fault set up
- Configurable input and output set up
- Meter calibration
- Paralleling setup
- Display language and units of measurement

Prime Mover Control

SAE-J1939 CAN interface to full authority ECMs (where applicable). Provides data transfer between genset and engine controller for control, metering and diagnostics.

12 V (DC) or 24 V (DC) nominal battery voltage is supported by PCC3300 for normal operation.

Temperature dependant prime mover governing dynamics: This function is supported enabling the engine to be responsive when warm and more stable when operating at lower temperature via providing control and modification over electronic governing parameters as a function of engine temperature.

Isochronous governing is provided in order to control prime mover speed within $\pm 0.25\%$ of nominal rated speed for any steady state load from no load to full load. During operation frequency drift should not exceed $\pm 0.5\%$ of nominal frequency given a 33°C (or 60°F) change in ambient temperature within an eight-hour period.

Droop electronic speed is governing capability is natively offered by PCC3300 to permit droop from 0% to 10% between no load to full load.

Remote start capability is built into the PCC3300 as the unit accepts a ground signal from remote devices to automatically command the starting of the generator set as well as the reaching of rated speed, voltage and frequency or otherwise run at idle speed until prime mover temperature is adequate. The presence of a remote start signal shall cause the PCC3300 to leave sleep mode and return to normal power mode. PCC3300 supports an option for delayed start or stop.

Remote Start Integrity: In compliance with NEC2017 Start Signal Integrity standard – NFPA70 Article 700.10(D)(3), the remote start circuit from ATS to PCC3300 is continuously monitored for signal disturbance due to broken, disconnected or shorted wires via a configurable input. Loss of signal integrity results in activation of a remote start signal.

Remote and local emergency stopping capability: PCC3300 accepts ground signal from a locally or remotely mounted emergency stop switch to cause the generator set to immediately shutdown. The generator set is prevented from either running or cranking with the emergency stop switch engaged. If PCC3300 is in sleep mode, then the activation of any emergency stop switch shall return PCC3300 to normal powered state along with the activation of the corresponding shutdown and run-prevention states.

Sleep mode: PowerCommand 3.3 supports a configurable low current draw state, which is designed with consideration to the needs of prime applications or other applications without a battery charger (in order to minimize battery current drain).

Automatic prime mover starting: Any generator set controlled by PCC3300 is capable of automatic starting achieved via either magnetic pickup or main alternator output frequency. PCC3300 additionally supports

configurable glow plug control where applicable.

Prime mover cycle cranking: PCC3300 supports configurable starting cycles and rest periods. Built-in starter protection is incorporated to prevent the operator from specifying a starting sequence that may be damaging.

Configurable time delay functionality: PCC3300 supports time delayed generator set starting and stopping (for cooldown). Permissible time delays are as follows (noting a default setting is 0 seconds):

1. Start delay: 0 seconds to 300 seconds prior to starting after receiving a remote start signal.
2. Stop delay: 0 seconds to 600 seconds prior to shut down after receiving a signal to stop in normal operation modes.

Lean Burn Natural Gas application specific parameters

PCC3300 supports prime mover inhibiting in order to permit application-specific processes (i.e. Auxiliaries) to be started first.

Generator Control

PCC3300 performs both Genset voltage sensing and Genset voltage regulation as follows:

- Voltage sensing is integrated into PCC3300 via three phase line-to-line sensing that is compatible with shunt or PMG excitation systems
- Automatic voltage regulation is accomplished by using a three phase fully rectified input and has a FET output for good motor starting capability.

Major features of generator control include:

Digital output voltage regulation - Capable of regulating output voltage to within $\pm 1.0\%$ for any loads between no load and full load. Voltage drift will not exceed $\pm 1.5\%$ for a 40 °C (104 °F) change in temperature in an eight-hour period. On engine starting or sudden load acceptance, voltage is controlled to a maximum of 5% overshoot over nominal level.

The automatic voltage regulator feature can be disabled to allow the use of an external voltage regulator.

Droop voltage regulation - Control can be adjusted to droop from 0-10% from no load to full load.

Torque-matched V/Hz overload control - The voltage roll-off set point and rate of decay (i.e. the slope of the V/Hz curve) is adjustable in the control.

Fault current regulation - PowerCommand[®] will regulate the output current on any phase to a maximum of three times rated current under fault conditions for both single phase and three phase faults. In conjunction with a permanent magnet generator, it will provide three times rated current on all phases for motor starting and short circuit coordination purpose.

Cylinder Cut-off System (CCS): PCC 3300 supports Cylinder Cut-off System which is used to operate the engines on half bank at no load and light load conditions. CCS has the following benefits on engine

performance- improved emission standards, improved fuel efficiency, reduced hydrocarbons, reduced white smoke, reduced wet stacking and higher exhaust temperature at light loads to improve turbocharger operations and catalyst performance.

Step Timing Control (STC): PCC 3300 supports STC functionality which is used to advance the engine timing of a hydro-mechanical engine during start up and light load conditions. During ADVANCED injection timing, it:

- Improves cold weather idling characteristics
- Reduces cold weather white smoke
- Improves light load fuel economy
- Reduces injector carboning

Paralleling Functions

First Start Sensor™ system – PowerCommand® provides a unique control function that positively prevents multiple gensets from simultaneously closing to an isolated bus under black start conditions. The First Start Sensor system is a communication system between the gensets that allows the gensets to work together to determine which genset is a system should be the first to close to the bus. The system includes an independent backup function, so that if the primary system is disabled the required functions are still performed.

Synchronizing – Control incorporates a digital synchronizing function to force the genset to match the frequency, phase and voltage of another source such as a utility grid. The synchronizer includes provisions to provide proper operation even with highly distorted bus voltage waveforms. The synchronizer can match other sources over a range of 60-110% of nominal voltage and -24 to +6 hertz. The synchronizer function is configurable for slip frequency synchronizing for applications requiring a known direction of power flow at instant of breaker closure or for applications where phase synchronization performance is otherwise inadequate.

Load sharing control – The genset control includes an integrated load sharing control system for both real (kW) and reactive (kVar) loads when the genset(s) are operating on an isolated bus. The control system determines kW load on the engine and kVar load on the alternator as a percent of genset capacity, and then regulates fuel and excitation systems to maintain system and genset at the same percent of load without impacting voltage or frequency regulation. The control can also be configured for operation in droop mode for kW or Kvar load sharing.

Load govern control– When PowerCommand® receives a signal indicating that the genset is paralleled with an infinite source such as a utility (mains) service, the genset will operate in load govern mode. In this mode the genset will synchronize and close to the bus, ramp to a pre-programmed kW and kVar load level, and then operate at that point. Control is adjustable for kW

values from 0-100% of standby rating, and 0.7-1.0 power factor (lagging). Default setting is 80% of standby and 1.0 power factor. The control includes inputs to allow independent control of kW and kVar load level by a remote device while in the load govern mode. The rate of load increase and decrease is also adjustable in the control. In addition, the control can be configured for operation in kW or kVAR load govern droop.

Load demand control – The control system includes the ability to respond to an external signal to initiate load demand operation. On command, the genset will ramp to no load, open its paralleling breaker, cool down, and shut down. On removal of the command, the genset will immediately start, synchronize, connect, and ramp to its share of the total load on the system.

Sync check – The sync check function decides when permissive conditions have been met to allow breaker closure. Adjustable criteria are: phase difference from 0.1-20 deg, frequency difference from 0.001-1.0 Hz, voltage difference from 0.5-10%, and a dwell time from 0.5-5.0 sec. Internally the sync check is used to perform closed transition operations. An external sync check output is also available.

Genset and utility/AC bus source AC metering – The control provides comprehensive three phase AC metering functions for both monitored sources, including: 3-phase voltage (L-L and L-N) and current, frequency, phase rotation, individual phase and totalized values of kW, kVAR, kVA and Power Factor; totalized positive and negative kW-hours, kVAR-hours, and kVA-hours. Three wire or four wire voltage connection with direct sensing of voltages to 600V, and up to 45kV with external transformers. Current sensing is accomplished with either 5 amp or 1 CT secondaries and with up to 10,000 amp primary. Maximum power readings are 32,000kW/kVAR/kVA.

Power transfer control – provides integrated automatic power transfer functions including source availability sensing, genset start/stop and transfer pair monitoring and control. The transfer/retransfer is configurable for open transition, fast closed transition (less than 100msec interconnect time), or soft closed transition (load ramping) sequences of operation. Utility source failure will automatically start genset and transfer load, retransferring when utility source returns. Test will start gensets and transfer load if test with load is enabled. Sensors and timers include:

Under voltage sensor: 3-phase L-N or L-L under voltage sensing adjustable for pickup from 85-100% of nominal. Dropout adjustable from 75-98% of pickup. Dropout delay adjustable from 0.1-30 sec.

Over voltage sensor: 3-phase L-N or L-L over voltage sensing adjustable for pickup from 95-99% of dropout. Dropout adjustable from 105-135% of nominal. Dropout delay adjustable from 0.5-120 sec. Standard configuration is disabled and is configurable to enabled in the field using the HMI or InPower service tools.

Over/Under frequency sensor: Center frequency adjustable from 45-65 Hz. Dropout bandwidth adjustable from 0.3-5% of center frequency beyond pickup bandwidth. Pickup bandwidth adjustable from 0.3-20% of center frequency. Field configurable to enable.

Loss of phase sensor: Detects out of range voltage phase angle relationship. Field configurable to enable.

Phase rotation sensor: Checks for valid phase rotation of source. Field configurable to enable.

Breaker tripped: If the breaker tripped input is active, the associated source will be considered as unavailable.

Timers: Control provides adjustable start delay from 0 - 300sec, stop delay from 0 - 800sec, transfer delay from 0-120sec, retransfer delay from 0-1800sec, programmed transition delay from 0-60sec, and maximum parallel time from 0-1800sec.

Negative Sequence Current Protection: PCC3300 supports this protection natively in order to determine if the generator is at any point was running subject to negative phase sequencing.

Breaker control – Utility and Genset breaker interfaces include separate relays for opening and closing breaker, as well as inputs for both 'a' and 'b' breaker position contacts and tripped status. Breaker diagnostics include Contact Failure, Fail to Close, Fail to Open, Fail to Disconnect, and Tripped. Upon breaker failure, appropriate control action is taken to maintain system integrity.

Exerciser clock –The exerciser clock (when enabled) allows the system to be operated at preset times in either test without load, test with load, or extended parallel mode. A Real Time Clock is built in. Up to 12 different programs can be set for day of week, time of day, duration, repeat interval, and mode. For example, a test with load for 1 hour every Tuesday at 2AM can be programmed. Up to 6 different exceptions can also be set up to block a program from running during a specific date and time period.

Extended paralleling – In extended paralleling mode (when enabled) the controller will start the genset and parallel to a utility source and then govern the real and reactive power output of the genset based on the desired control point. The control point for the real power (kW) can be configured for either the genset metering point ("Base Load") or the utility metering point ("Peak Shave"). The control point for the reactive power (kVAR or Power Factor) can also be independently configured for either the genset metering point or the utility metering point. This flexibility would allow base kW load from the genset while maintaining the utility power factor at a reasonable value to avoid

penalties due to low power factor. The System always operates within genset ratings. The control point can be changed while the system is in operation. Set points can be adjusted via hardwired analog input or adjusted through an operator panel display or service tool.

Application types – Controller is configured to operating in one of six possible application types. These topologies are often used in combinations in larger systems, with coordination of the controllers in the system either by external device or by interlocks provided in the control. Topologies that may be selected in the control include:

Standalone: Control provides monitoring, protection and control in a non-paralleling application.

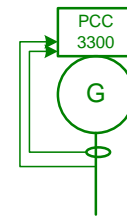

Synchronizer only: control will synchronize the genset to other source when commanded to either via a hardwired or Modbus driven input.

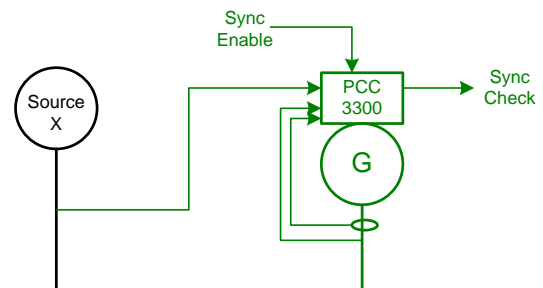

Isolated Bus: allows the genset to perform a dead bus closure or synchronize to the bus and isochronously share kW and kVAR loads with other gensets.

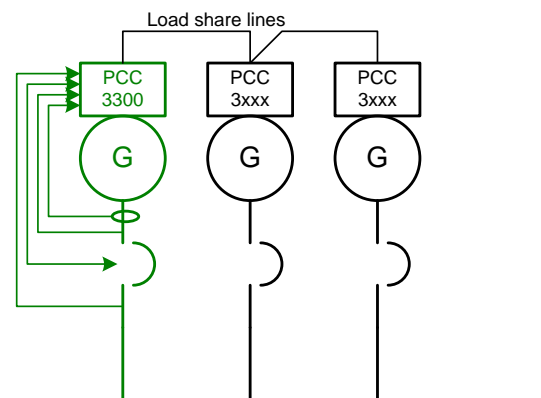

Utility Single: Control monitors one genset and utility. The control will automatically start and provide power to a load if the utility fails. The control will also resynchronize the genset back to the utility and provides extended paralleling capabilities.

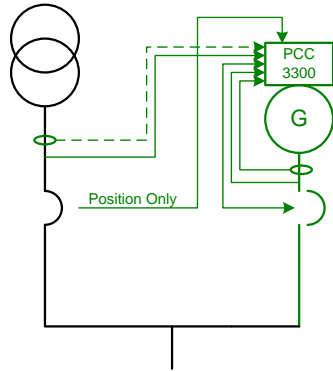

Utility Multiple: Supports all functionality of Isolated Bus and provides extended paralleling to the utility. Extended paralleling load set points follow a constant setting; dynamically follow an analog input, Modbus register or HMI.

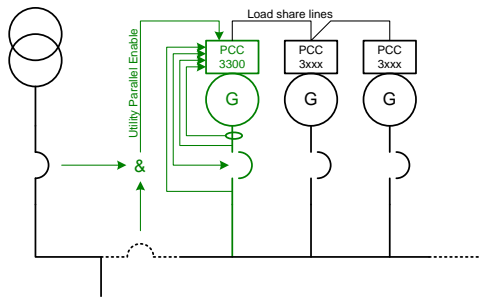

Power Transfer Control: Control operates a single genset/single utility transfer pair in open transition, fast closed transition, or soft closed transition. Extended paralleling functionality also provides base load and peak shave options.

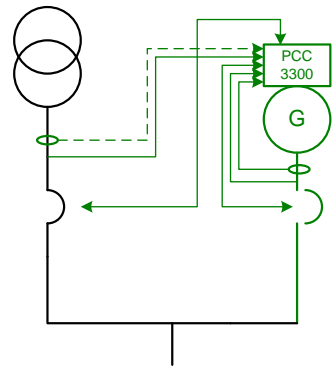

Masterless Load Demand (Optional Feature):

PowerCommand® 3.3 with Masterless Load Demand (MLD) technology enables generator sets to start/stop automatically based on load demand. Masterless Load Demand-capable generators are equipped with an additional s-CAN network connection that allows sharing of information amongst paralleled generator sets. MLD has been designed for hassle-free installation, commissioning and operation. MLD functionality. Integrated on-board system logic provides the MLD topology control without the need for any additional system.

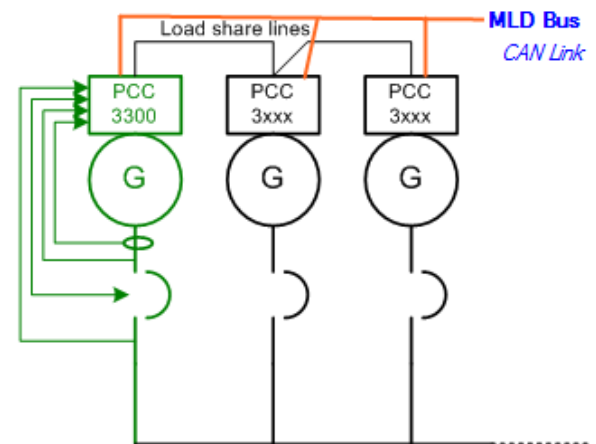
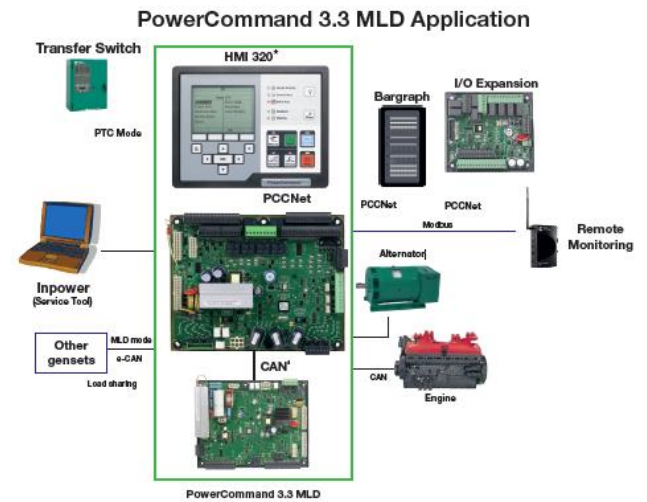

PCC3300 External Voltage and Frequency Biasing Inputs

PCC3300 supports externally driven voltage and frequency biasing capability in order to permit external paralleling (if intending to use this feature please contact your local distributor for further information).

Protective Functions

On operation of a protective function the control will indicate a fault by illuminating the appropriate status LED on the HMI, as well as display the fault code and fault description on the LCD. The nature of the fault and time of occurrence are logged in the control. The service manual and InPower service tool provide service keys and procedures based on the service codes provided. Protective functions include:

Battle short mode

When enabled and the *battle short* switch is active, the control will allow some shutdown faults to be bypassed. If a bypassed shutdown fault occurs, the fault code and description will still be annunciated, but the genset will not shutdown. This will be followed by a *fail to shutdown* fault. Emergency stop shutdowns and others that are critical for proper operation (or are handled by the engine ECM) are not bypassed. Please refer to the Control Application Guide or Manual for list of these faults.

Derate

The Derate function reduces output power of the genset in response to a fault condition. If a Derate command occurs while operating on an isolated bus, the control will issue commands to reduce the load on the genset via contact closures or Modbus. If a Derate command occurs while in utility parallel mode, the control will actively reduce power by lowering the base load kW to the derated target kW.

Configurable alarm and status inputs

The control accepts up to four alarm or status inputs (configurable contact closed to ground or open) to indicate a configurable (customer-specified) condition.

The control is programmable for warning, derate, shutdown, shutdown with cooldown or status indication and for labeling the input.

Emergency stop

Annunciated whenever either emergency stop signal is received from external switch.

General prime mover protection

Low and high battery voltage warning - Indicates status of battery charging system (failure) by continuously monitoring battery voltage.

Weak battery warning - The control system will test the battery each time the genset is signaled to start and indicate a warning if the battery indicates impending failure.

Low coolant level warning – Can be set up to be a warning or shutdown.

Low coolant temperature warning – Indicates that engine temperature may not be high enough for a 10 second start or proper load acceptance.

Fail to start (overcrank) shutdown - The control system will indicate a fault if the genset fails to start by the completion of the engine crank sequence.

Fail to crank shutdown - Control has signaled starter to crank engine but engine does not rotate.

Cranking lockout - The control will not allow the starter to attempt to engage or to crank the engine when the engine is rotating.

Fault simulation –The control in conjunction with InPower software, will accept commands to allow a technician to verify the proper operation of the control and its interface by simulating failure modes or by forcing the control to operate outside of its normal operating ranges. InPower also provides a complete list of faults and settings for the protective functions provided by the controller.

For Lean Burn Natural Gas Engine applications:

Off load running (protection) – This feature protects the engine in the event the genset is being called to go off load for too long.

Hydro Mechanical fuel system engine protection:

Overspeed shutdown – Default setting is 115% of nominal

Low lube oil pressure warning/shutdown – Level is preset (configurable with InPower or HMI) to match the capabilities of the engine used. Control includes time delays to prevent nuisance alarms.

High lube oil temperature warning/shutdown – Level is preset (configurable with InPower or HMI) to match the capabilities of the engine used. Control includes time delays to prevent nuisance alarms.

High engine temperature warning/shutdown – Level is preset (configurable with InPower or HMI) to match the capabilities of the engine used. Control includes time delays to prevent nuisance alarms.

Low coolant temperature warning – Indicates that engine temperature may not be high enough for a 10 second start or proper load acceptance.

High intake manifold temperature shutdown – Level is preset (configurable with InPower or HMI) to match the capabilities of the engine used. Control includes time delays to prevent nuisance alarms.

Full authority electronic engine protection:

Engine fault detection is handled inside the engine ECM. Fault information is communicated via the SAE-J1939 data link for annunciation in the HMI.

Alternator Protection

AmpSentry protective relay - A comprehensive monitoring and control system integral to the PowerCommand® Control System that guards the electrical integrity of the alternator and power system by providing protection against a wide array of fault conditions in the genset or in the load. It also provides single and three phase fault current regulation (3x Current) so that downstream protective devices have the maximum current available to quickly clear fault conditions without subjecting the alternator to potentially catastrophic failure conditions. Thermal damage curve (3 phase short) or fixed timer (2sec for 1P short, 5sec for 2P short). See document R1053 for a full-size time over current curve. The control does not include protection required for interconnection to a utility (mains) service.

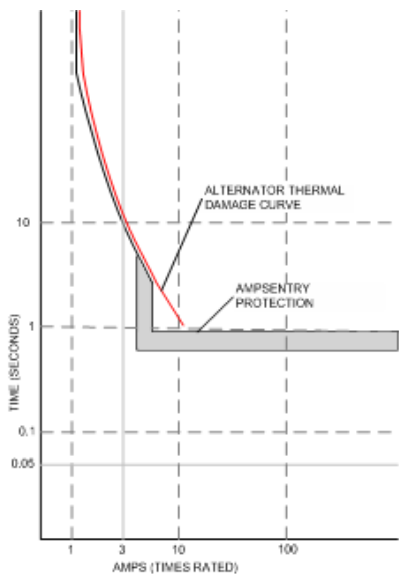

AmpSentry Maintenance Mode (AMM) - Instantaneous tripping, if AmpSentry Maintenance mode is active (50mS response to turn off AVR excitation/shutdown genset) for arc flash reduction when personnel are near genset.

High AC voltage shutdown (59) - Output voltage on any phase exceeds preset values. Time to trip is inversely proportional to amount above threshold. Values adjustable from 105-125% of nominal voltage, with time delay adjustable from 0.1-10 seconds. Default value is 110% for 10 seconds.

Low AC voltage shutdown (27) - Voltage on any phase has dropped below a preset value. Adjustable over a range of 50-95% of reference voltage, time delay 2-20 seconds. Default value is 85% for 10 seconds. Function tracks reference voltage. Control does not nuisance trip when voltage varies due to the control directing voltage to drop, such as during a V/Hz roll-off or synchronizing.

Under frequency shutdown (81 u) - Genset output frequency cannot be maintained. Settings are adjustable from 2-10 Hz below reference governor set point, for a 5-20 second time delay. Default: 6 Hz, 10 seconds. Under frequency protection is disabled when excitation is switched off, such as when engine is operating in idle speed mode.

Over frequency shutdown/warning (81o) - Genset is operating at a potentially damaging frequency level. Settings are adjustable from 2-10 Hz above nominal governor set point for a 1-20 second time delay. Default: 6 Hz, 20 seconds, disabled.

Overcurrent warning/shutdown (51) - Implementation of the thermal damage curve with instantaneous trip level calculated based on current transformer ratio and application power rating.

Loss of sensing voltage shutdown - Shutdown of genset will occur on loss of voltage sensing inputs to the control.

Field overload shutdown - Monitors field voltage to shutdown genset when a field overload condition occurs.

Over load (kW) warning - Provides a warning indication when engine is operating at a load level over a set point. Adjustment range: 80-140% of application rated kW, 0-120 second delay. Defaults: 105%, 60 seconds.

Reverse power shutdown (32) - Adjustment range: 5-20% of standby kW rating, delay 1-15 seconds. Default: 10%, 3 seconds.

Reverse Var shutdown (40) - Shutdown level is adjustable: 15-50% of rated Var output, delay 10-60 seconds. Default: 20%, 10 seconds.

Short circuit protection - Output current on any phase is more than 175% of rating and approaching the thermal damage point of the alternator. Control includes algorithms to protect alternator from repeated over current conditions over a short period of time.

Negative sequence overcurrent warning (46) - Control protects the generator from damage due to excessive imbalances in the three phase load currents and/or power factors.

Custom overcurrent warning/shutdown (51) - Control provides the ability to have a custom time overcurrent protection curve in addition to the AmpSentry protective relay function.

Ground fault overcurrent (51G) - Control detects a ground fault either by an external ground fault relay via a contact input or the control can measure the ground current from an external current transformer. Associated time delays and thresholds are adjustable via InPower or HMI.

Paralleling Protection

Breaker fail to close Warning: When the control signals a circuit breaker to close, it will monitor the breaker auxiliary contacts and verify that the breaker has closed. If the control does not sense a breaker closure within an adjustable time period after the close signal, the fail to close warning will be initiated.

Breaker fail to open warning: The control system monitors the operation of breakers that have been signaled to open. If the breaker does not open within an adjustable time delay, a Breaker Fail to Open warning is initiated.

Breaker position contact warning: The controller will monitor both 'a' and 'b' position contacts from the breaker. If the contacts disagree as to the breaker position, the breaker position contact warning will be initiated.

Breaker tripped warning: The control accepts inputs to monitor breaker trip / bell alarm contact and will initiate a breaker tripped warning if it should activate.

Fail to disconnect warning: In the controller is unable to open either breaker, a fail to disconnect warning is initiated. Typically, this would be mapped to a configurable output, allowing an external device to trip a breaker.

Fail to synchronize warning: Indicates that the genset could not be brought to synchronization with the bus. Configurable for adjustable time delay of 10 -900 seconds, 120 default.

Phase sequence sensing warning: Verifies that the genset phase sequence matches the bus prior to allowing the paralleling breaker to close.

Maximum parallel time warning (power transfer control mode only): During closed transition load transfers, control independently monitors paralleled time. If time is exceeded, warning is initiated and genset is disconnected.

Bus or genset PT input calibration warning: The control system monitors the sensed voltage from the bus and genset output voltage potential transformers. When the paralleling breaker is closed, it will indicate a warning condition if the read values are different.

Field Control Interface

Input signals to the PowerCommand® control include:

- Coolant level (where applicable)
- Fuel level (where applicable)
- Remote emergency stop
- Remote fault reset
- Remote start
- Rupture basin
- Start type signal
- Battle short
- Load demand stop
- Synchronize enable
- Genset circuit breaker inhibit
- Utility circuit breaker inhibit
- Single mode verify
- Transfer inhibit – prevent transfer to utility (in power transfer control mode)
- Retransfer inhibit – prevent retransfer to genset (in power transfer control mode)
- kW and kVAR load setpoints

Configurable inputs - Control includes (4) input signals from customer discrete devices that are configurable for warning, shutdown or status indication, as well as message displayed

Input signals for Lean Burn Natural Gas Engine applications:

- Gearbox oil pressure/temperature protection
- Fire fault
- Earth fault support as a discrete input via an appropriate secondary detection device
- Differential fault
- DC power supply fault
- Genset Interface Box (GIB) isolator open fault
- Start inhibit/enable (x3)
- Radiator fan trip
- Ventilator fan trip
- Ventilation louvers closed
- Start system trip
- Alternator heater trip
- Alternator heater status
- Alternator winding temperature (PT100 RTDx3)
- Alternator drive end bearing temperature (PT100 RTD)
- Alternator non-drive end bearing temperature (PT100 RTD)

Output signals from the PowerCommand® control include:

- Load dump signal: Operates when the genset is in an overload condition.
- Delayed off signal: Time delay-based output which will continue to remain active after the control has removed the run command. Adjustment range: 0 - 120 seconds. Default: 0 seconds.

- Configurable relay outputs: Control includes (4) relay output contacts (3 A, 30VDC). These outputs can be configured to activate on any control warning or shutdown fault as well as ready to load, not in auto, common alarm, common warning and common shutdown.
- Ready to load (genset running) signal: Operates when the genset has reached 90% of rated speed and voltage and latches until genset is switched to off or idle mode.
- Paralleling circuit breaker relays outputs: Control includes (4) relay output contacts (3.5A, 30 VDC) for opening and closing of the genset and utility breakers.

Output Signals for Lean Burn Natural Gas Engine applications:

- Start inhibit/enable event
- Emergency stop event
- Ventilator fan run control
- Louvre control
- Radiator fan control
- Alternator heater control
- Engine at idle speed event

Communications connections include:

- PC tool interface: This RS-485 communication port allows the control to communicate with a personal computer running InPower software.
- Modbus RS-485 port: Allows the control to communicate with external devices such as PLCs using Modbus protocol.

Note - An RS-232 or USB to RS-485 converter is required for communication between PC and control.

- Networking: This RS-485 communication port allows connection from the control to the other Cummins Power Generation products.

Mechanical Drawing

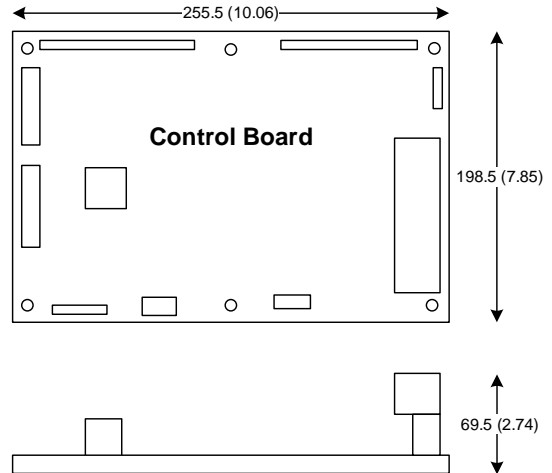

PowerCommand® Human Machine Interface HMI320



Description

This control system includes an intuitive operator interface panel that allows for complete genset control as well as system metering, fault annunciation, configuration and diagnostics. The interface includes five genset status LED lamps with both internationally accepted symbols and English text to comply with customer's needs. The interface also includes an LED backlit LCD display with tactile feel soft-switches for easy operation and screen navigation. It is configurable for units of measurement and has adjustable screen contrast and brightness.

The run/off/auto switch function is integrated into the interface panel.

All data on the control can be viewed by scrolling through screens with the navigation keys. The control displays the current active fault and a time-ordered history of the five previous faults.

Features:

- LED indicating lamps
 - genset running
 - remote start
 - not in auto
 - shutdown
 - warning
 - auto
 - manual and stop
 - Circuit breaker open (if equipped)
 - Circuit breaker closed (if equipped)
- 320 x 240 pixels graphic LED backlight LCD.
- Four tactile feel membrane switches for LCD defined operation. The functions of these switches are defined dynamically on the LCD.
- Seven tactile feel membrane switches dedicated screen navigation buttons for up, down, left, right, ok, home and cancel.

- Six tactile feel membrane switches dedicated to control for auto, stop, manual, manual start, fault reset and lamp test/panel lamps.
- Two tactile feel membrane switches dedicated to control of circuit breaker (where applicable).
- Allows for complete genset control setup.
- Certifications: Suitable for use on gensets that are designed, manufactured, tested and certified to relevant UL, NFPA, ISO, IEC, Mil Std., UKCA and CE standards.
- Languages supported: English, Spanish, French, German, Italian, Greek, Portuguese, Finnish, Norwegian, Danish, Russian (Cyrillic), Chinese, Hungarian, Japanese, Polish, Korean, Romanian, Brazilian Portuguese, Turkish, Dutch, and Czech

Communications connections include:

- PC tool interface - This RS-485 communication port allows the HMI to communicate with a personal computer running InPower.
- This RS-485 communication port allows the HMI to communicate with the main control board.

Mechanical Drawing

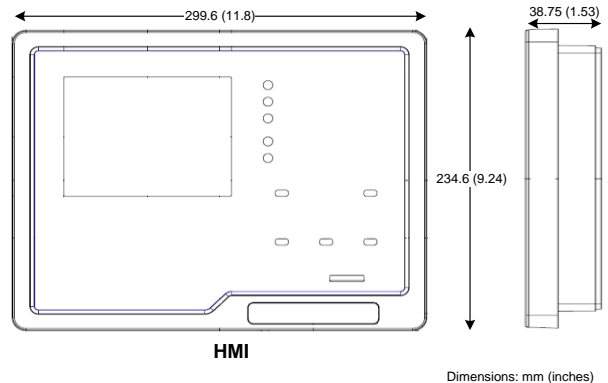

Software

InPower (beyond 6.5 version) is a PC-based software service tool that is designed to directly communicate to PowerCommand® gensets and transfer switches, to facilitate service and monitoring of these products.

Environment

The control is designed for proper operation without recalibration in ambient temperatures from -40 °C (-40 °F) to +70° C (158 °F), and for storage from -55 °C (-67 °F) to +80 °C (176 °F). Control will operate with humidity up to 95%, non-condensing.

The HMI is designed for proper operation in ambient temperatures from -20 °C (-4 °F) to +70 °C (158 °F), and for storage from -30 °C (-22 °F) to +80 °C (176 °F).

The control board is fully encapsulated to provide superior resistance to dust and moisture. Display panel has a single membrane surface, which is impervious to effects of dust, moisture, oil and exhaust fumes. This panel uses a sealed membrane to provide long reliable service life in harsh environments.

The control system is specifically designed and tested for resistance to RFI/EMI and to resist effects of vibration to provide a long reliable life when mounted on a genset. The control includes transient voltage surge suppression to provide compliance to referenced standards.

Certifications

PowerCommand® meets or exceeds the requirements of the following codes and standards:

- NFPA 110 for level 1 and 2 systems.
- ISO 8528-4:2005 compliance, controls and switchgear (second edition)
- CE marking: The CE marking is only valid when equipment is used in a fixed installation application. Material compliance declaration is available upon request.
- UKCA marking- The UKCA marking is only valid when equipment is used in a fixed installation application. Material compliance declaration is available upon request.
- EN 50081-1,2 residential/light industrial emissions or industrial emissions.
- EN 50082-1,2 residential/light industrial or industrial susceptibility.
- ISO 7637-2, level 2; DC supply surge voltage test.
- Mil Std 202C, Method 101 and ASTM B117: Salt fog test.
- UL 6200 recognized, suitable for use on UL 2200 Listed generator sets.
- CSA C282-M1999 compliance
- CSA 22.2 No. 14 M91 industrial controls.
- PowerCommand® control systems and generator sets are designed and manufactured in ISO 9001 certified facilities.
- ROHS (Restriction of Hazardous substance) complaint both for HMI 320 & PCC3300v2.

Reference Documents

Please refer to the following reference documents available in the PowerSuite library:

- PowerCommand™ 3.3. Application Guide
- T-037: PowerCommand Control Application Manual (ANSI Protective Functions)
- T-040: PowerCommand 3.3 Paralleling Application Guide

Please refer to the following reference documents available on Cummins Quickserve:

- Service Manuals for PC3.3 (non-MLD) and PC3.3 (MLD)
- Modbus Register Mapping

Warranty

All components and subsystems are covered by an express limited one-year warranty. Other optional and extended factory warranties and local distributor maintenance agreements are available.





Alternator Data Sheet

Frame Size: S7L1D-J4

| Characteristics | | | | | |
|--------------------------------------------|------------------------|----------------------------------|---------------------|---------------------|---------------------|
| | No of Bearings: | | 1-bearing | | 2-bearing |
| Weights: | Stator assembly: | 4698 lb | 2131 kg | 4698 lb | 2131 kg |
| | Rotor assembly: | 4026 lb | 1826 kg | 3896 lb | 1767 kg |
| | Complete assembly: | 9954 lb | 4515 kg | 9877 lb | 4480 kg |
| Maximum speed: | | 2250 rpm | | | |
| Excitation current: | Full load: | Wdg 13: 3.5, Wdg 312: 3.2 | | | |
| | No load: | Wdg 13: 1.27, Wdg 312: 0.88-0.86 | | | |
| Insulation system: | Class H throughout | | | | |
| 3 Ø Ratings (0.8 power factor) | | 60 Hz (winding no) | | | |
| | | <u>380</u> (13) | <u>440</u> (312) | <u>480</u> (312) | |
| 163° C rise ratings | @ 27° C | kW | 2485 | 2350 | 2560 |
| | | kVA | 3106 | 2938 | 3200 |
| 150° C rise ratings | @ 40° C | kW | 2415 | 2294 | 2500 |
| | | kVA | 3019 | 2868 | 3125 |
| 125° C rise ratings | @ 40° C | kW | 2280 | 2200 | 2400 |
| | | kVA | 2850 | 2750 | 3000 |
| 105° C rise ratings | @ 40° C | kW | 2095 | 2015 | 2200 |
| | | kVA | 2619 | 2519 | 2750 |
| 80° C rise ratings | @ 40° C | kW | 1825 | 1760 | 1920 |
| | | kVA | 2281 | 2200 | 2400 |
| 3 Ø Reactances | | | <u>380</u> (13) | <u>440</u> (312) | <u>480</u> (312) |
| (Based on full load at 125° C rise rating) | | | | | |
| Synchronous | | | 2.46 | 2.57 | 2.36 |
| Transient | | | 0.18 | 0.17 | 0.16 |
| Subtransient | | | 0.14 | 0.13 | 0.12 |
| Negative sequence | | | 0.17 | 0.17 | 0.15 |
| Zero sequence | | | 0.03 | 0.04 | 0.03 |
| 3 Ø Motor starting | | | <u>380</u> (13) | <u>440</u> (312) | <u>480</u> (312) |
| Maximum kVA (90% sustained voltage) | | | 2539 | 2543 | 2526 |
| Time constants (sec) | | | <u>380</u> (13) | <u>440</u> (312) | <u>480</u> (312) |
| Transient | | | 0.178 | 0.164 | 0.164 |
| Subtransient | | | 0.009 | 0.008 | 0.008 |
| Open circuit | | | 4.85 | 4.98 | 4.98 |
| DC | | | 0.038 | 0.037 | 0.037 |
| Windings (@22° C) | | | <u>380</u> (13) | <u>440</u> (312) | <u>480</u> (312) |
| Stator resistance | (L-L Ohms) | 0.0008 | 0.0012 | 0.0012 | |
| Rotor resistance | (Ohms) | 1.84 | 1.84 | 1.84 | |
| Number of leads | | 6 | 6 | 6 | |



Alternator Data Sheet

Frame Size: S7L1D-J4

S7L1D-J4 Wdg.312

THREE PHASE EFFICIENCY CURVES

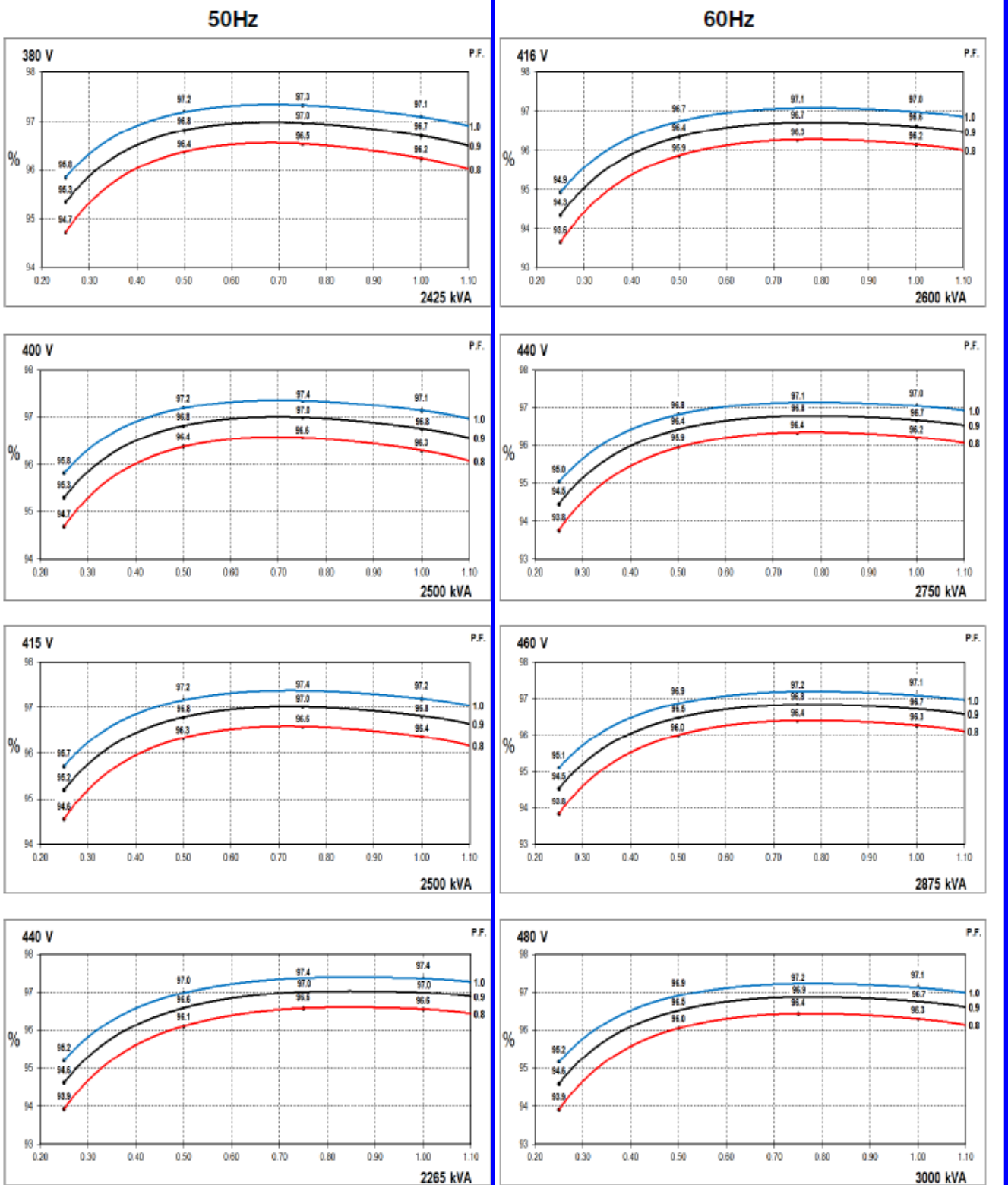



Alternator Data Sheet Frame Size: S7L1D-J4

S7L1D-J4 & S7L1W-J4 (Industrial) Wdg.312

Locked Rotor Motor Starting Curves - Separately Excited

50Hz

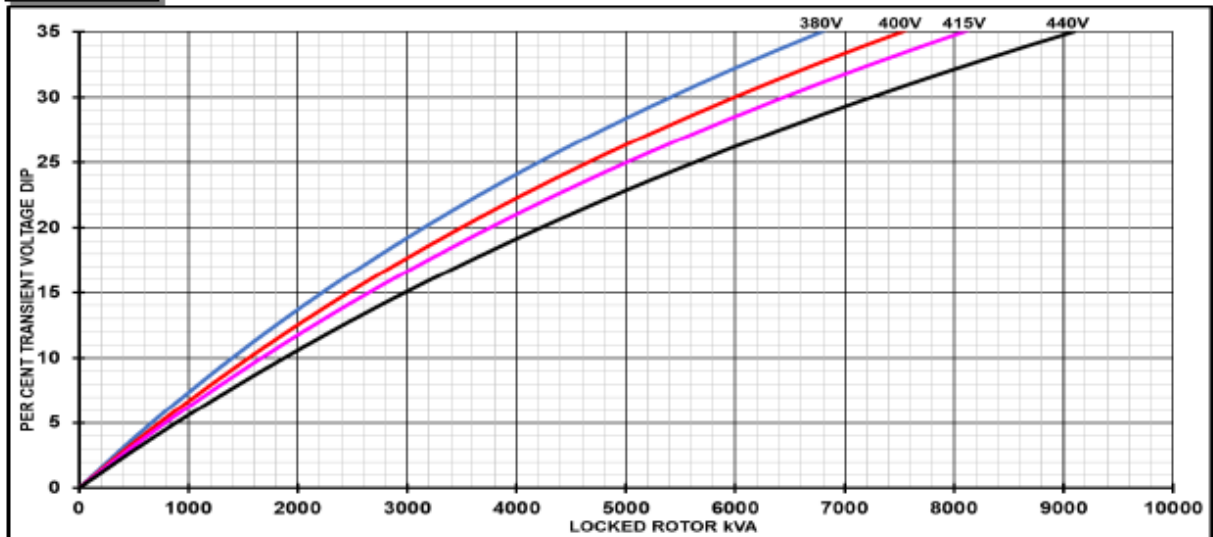

60Hz

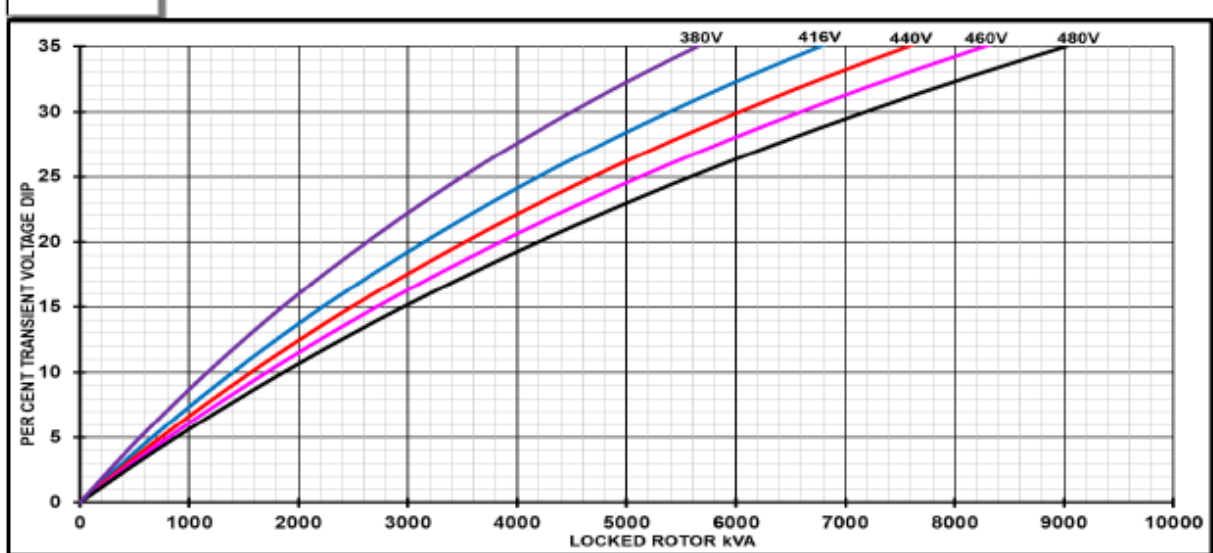

| Transient Voltage Dip Scaling Factor | | Transient Voltage Rise Scaling Factor | |
|--------------------------------------|----------------|---------------------------------------|----------------|
| Lagging PF | Scaling Factor | Lagging PF | Scaling Factor |
| <= 0.4 | 1.00 | <= 0.4 | 1.25 |
| 0.5 | 0.95 | 0.5 | 1.20 |
| 0.6 | 0.90 | 0.6 | 1.15 |
| 0.7 | 0.86 | 0.7 | 1.10 |
| 0.8 | 0.83 | > 0.7 | 1.00 |
| 0.9 | 0.75 | | |
| 0.95 | 0.70 | | |
| 1 | 0.65 | | |

Note: To determine % Transient Voltage Dip or Voltage Rise at various PF, multiply the % Voltage Dip from the curve directly by the Scaling Factor.



Alternator Data Sheet

Frame Size: S7L1D-J4

S7L1D-J4 & S7L1W-J4 (Industrial) Wdg.312

Three-phase Short Circuit Decrement Curve - Separately Excited

50Hz

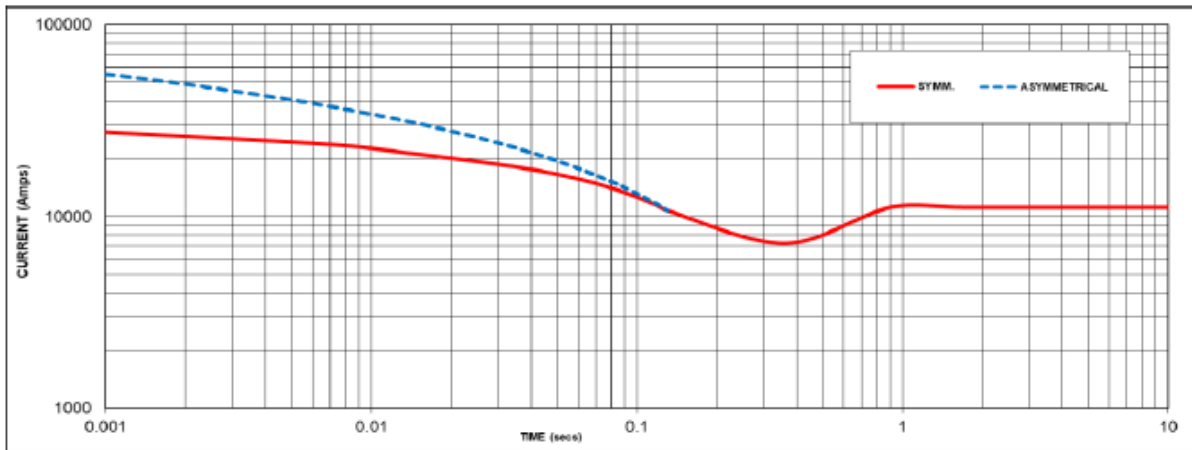

60Hz

Sustained Short Circuit = 11142 Amps

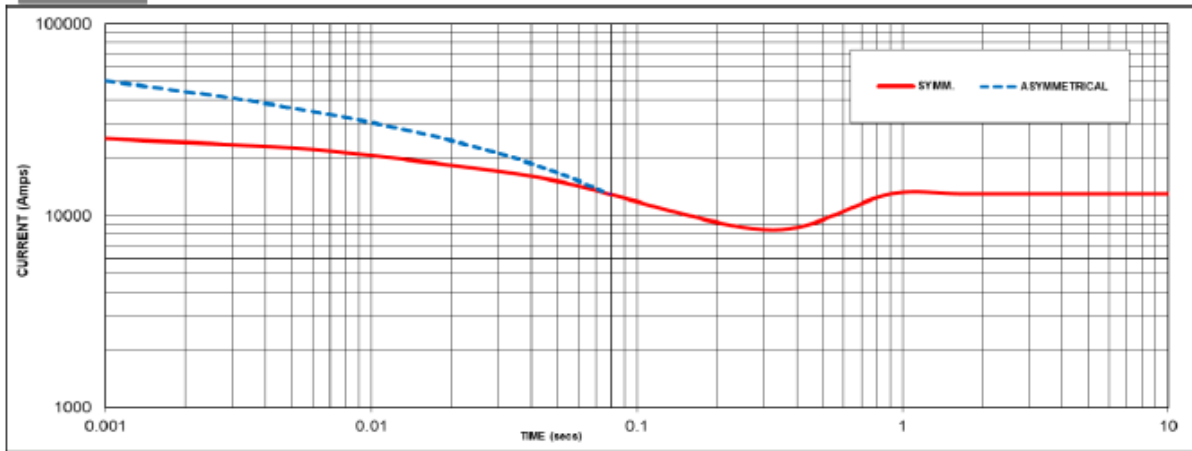

Sustained Short Circuit = 12987 Amps

Note 1

The following multiplication factors should be used to adjust the values from curve between time 0.001 seconds and the minimum current point in respect of nominal operating voltage :

| 50Hz | | 60Hz | |
|---------|--------|---------|--------|
| Voltage | Factor | Voltage | Factor |
| 380V | X 1.00 | 416V | X 1.00 |
| 400V | X 1.05 | 440V | X 1.06 |
| 415V | X 1.09 | 460V | X 1.10 |
| 440V | X 1.16 | 480V | X 1.15 |

The sustained current value is constant irrespective of voltage level

Note 2

The following multiplication factor should be used to convert the values calculated in accordance with NOTE 1 to those applicable to the various types of short circuit :

| | 3-phase | 2-phase L-L | 1-phase L-N |
|-------------------------|---------|-------------|-------------|
| Instantaneous | x 1.00 | x 0.87 | x 1.30 |
| Minimum | x 1.00 | x 1.80 | x 3.20 |
| Sustained | x 1.00 | x 1.50 | x 2.50 |
| Max. sustained duration | 10 sec. | 5 sec. | 2 sec. |

Note 3

All other times are unchanged
Curves are drawn for Star connections under no-load excitation at rated speeds. For other connection (where applicable) the following multipliers should be applied to current values as shown :

Parallel Star = Curve current value X 2
Series Delta = Curve current value X 1.732



Sound Data

C2000D6E

QSK50-G24 60Hz Diesel

A-weighted Sound Pressure Level @ 7 meters, dB(A)

See notes 2, 5 and 7-11 listed below

| Configuration | Exhaust | Applied Load | Position (Note 2) | | | | | | | | 8 Position Average |
|--------------------------------------------|------------------|--------------|-------------------|-------|-------|-------|------|------|------|------|--------------------|
| | | | 1 | 2 | 3 | 4 | 5 | 6 | 7 | 8 | |
| Standard – Unhoused (40°C Cooling Package) | Infinite Exhaust | 0% Standby | 89.3 | 93.4 | 93.4 | 95.6 | 92.9 | 94.7 | 94.9 | 96.2 | 94.2 |
| | | 50% Standby | 92.5 | 104.2 | 100.2 | 102.6 | 95.1 | 97.1 | 97.1 | 97.3 | 99.7 |
| | | 75% Standby | 93.1 | 104.0 | 101.3 | 104.0 | 95.9 | 97.2 | 97.2 | 97.5 | 100.3 |
| | | 100% Standby | 92.8 | 103.3 | 101.1 | 104.1 | 96.6 | 97.5 | 97.5 | 97.6 | 100.2 |
| | | 100% Prime | 92.9 | 104.1 | 101.1 | 104.1 | 96.8 | 97.5 | 97.5 | 97.6 | 100.4 |

Average A-weighted Sound Pressure Level @ 1 meter, dB(A)

See notes 1, 5 and 7-14 listed below

| Configuration | Exhaust | Applied Load | Octave Band Center Frequency (Hz) | | | | | | | | | | | Overall Sound Pressure Level | |
|--------------------------------------------|------------------|--------------|-----------------------------------|------|-----|-----|-----|-----|------|------|------|------|-------|------------------------------|-----|
| | | | 16 | 31.5 | 63 | 125 | 250 | 500 | 1000 | 2000 | 4000 | 8000 | 16000 | | |
| Standard – Unhoused (40°C Cooling Package) | Infinite Exhaust | 0% Standby | N/A | N/A | N/A | N/A | N/A | N/A | N/A | N/A | N/A | N/A | N/A | N/A | N/A |
| | | 50% Standby | N/A | N/A | N/A | N/A | N/A | N/A | N/A | N/A | N/A | N/A | N/A | N/A | N/A |
| | | 75% Standby | N/A | N/A | N/A | N/A | N/A | N/A | N/A | N/A | N/A | N/A | N/A | N/A | N/A |
| | | 100% Standby | N/A | N/A | N/A | N/A | N/A | N/A | N/A | N/A | N/A | N/A | N/A | N/A | N/A |
| | | 100% Prime | N/A | N/A | N/A | N/A | N/A | N/A | N/A | N/A | N/A | N/A | N/A | N/A | N/A |

A-weighted Sound Pressure Level @ Operator Location, dB(A)

See notes 1, 5 and 7-15 listed below

| Configuration | Exhaust | Applied Load | Octave Band Center Frequency (Hz) | | | | | | | | | | | Overall Sound Pressure Level | |
|--------------------------------------------|------------------|--------------|-----------------------------------|------|------|------|------|------|------|------|------|------|-------|------------------------------|-----|
| | | | 16 | 31.5 | 63 | 125 | 250 | 500 | 1000 | 2000 | 4000 | 8000 | 16000 | | |
| Standard – Unhoused (40°C Cooling Package) | Infinite Exhaust | 0% Standby | N/A | N/A | N/A | N/A | N/A | N/A | N/A | N/A | N/A | N/A | N/A | N/A | N/A |
| | | 50% Standby | N/A | N/A | N/A | N/A | N/A | N/A | N/A | N/A | N/A | N/A | N/A | N/A | N/A |
| | | 75% Standby | N/A | 49.0 | 64.7 | 83.1 | 89.5 | 99.1 | 94.9 | 90.6 | 88.1 | 93.4 | 80.2 | 102.1 | |
| | | 100% Standby | N/A | 49.1 | 65.4 | 83.4 | 89.6 | 98.7 | 94.8 | 91.0 | 89.3 | 91.5 | 81.2 | 101.8 | |
| | | 100% Prime | N/A | 49.1 | 65.3 | 83.3 | 89.8 | 98.7 | 94.9 | 91.3 | 89.8 | 90.6 | 81.5 | 101.8 | |



Sound Data

C2000D6E

KTA50-G24 60Hz Diesel

A-weighted Sound Power Level, dB(A)

See notes 1, 3 and 6-14 listed below

| Configuration | Exhaust | Applied Load | Octave Band Center Frequency (Hz) | | | | | | | | | | | Overall Sound Power Level |
|--------------------------------------------|------------------|--------------|-----------------------------------|------|------|-------|-------|-------|-------|-------|-------|-------|-------|---------------------------|
| | | | 16 | 31.5 | 63 | 125 | 250 | 500 | 1000 | 2000 | 4000 | 8000 | 16000 | |
| Standard – Unhoused (40°C Cooling Package) | Infinite Exhaust | 0% Standby | N/A | 71.1 | 84.7 | 104.3 | 111.8 | 117.4 | 117.2 | 114.3 | 110.6 | 104.2 | 93.5 | 122.2 |
| | | 50% Standby | N/A | 73.8 | 85.8 | 105.3 | 112.4 | 117.5 | 117.7 | 115.9 | 116.5 | 123.8 | 115.3 | 126.9 |
| | | 75% Standby | N/A | 73.5 | 86.0 | 105.5 | 112.4 | 117.5 | 117.8 | 116.7 | 119.2 | 125.5 | 116.9 | 128.3 |
| | | 100% Standby | N/A | 72.8 | 86.4 | 106.0 | 112.5 | 117.7 | 118.4 | 117.8 | 121.2 | 123.3 | 118.0 | 127.9 |
| | | 100% Prime | N/A | 73.1 | 86.3 | 105.4 | 112.3 | 117.6 | 118.2 | 117.4 | 120.7 | 124.1 | 117.9 | 128.0 |

Exhaust Sound Power Level, dB(A)

See notes 4 and 6-14 listed below

| Configuration | Applied Load | Octave Band Center Frequency (Hz) | | | | | | | | | | | Overall Sound Power Level |
|-------------------------------------|--------------|-----------------------------------|------|-------|-------|-------|-------|-------|-------|-------|-------|-------|---------------------------|
| | | 16 | 31.5 | 63 | 125 | 250 | 500 | 1000 | 2000 | 4000 | 8000 | 16000 | |
| Standard - Unhoused (With Tailpipe) | 0% Standby | N/A | 70.9 | 87.8 | 103.3 | 111.4 | 108.7 | 108.8 | 111.3 | 109.4 | 98.6 | 84.2 | 117.3 |
| | 50% Standby | N/A | 78.3 | 100.4 | 114.3 | 119.2 | 119.3 | 122.5 | 127.2 | 124.8 | 118.0 | 106.6 | 131.0 |
| | 75% Standby | N/A | 77.8 | 102.8 | 116.7 | 122.5 | 126.0 | 129.4 | 131.9 | 130.8 | 125.1 | 114.5 | 136.7 |
| | 100% Standby | N/A | 78.2 | 103.6 | 118.5 | 124.1 | 127.0 | 131.0 | 134.4 | 134.3 | 129.1 | 117.4 | 139.2 |
| | 100% Prime | N/A | 77.3 | 103.3 | 118.1 | 123.7 | 126.8 | 130.6 | 133.9 | 133.6 | 128.2 | 116.6 | 138.7 |

Global Notes:

1. Sound pressure levels at 1 meter are measured per the requirements of ISO 3744, ISO 8528-10, and European Communities Directive 2000/14/EC as applicable. The microphone measurement locations are 1 meter from a reference parallelepiped just enclosing the generator set (enclosed or unenclosed).
2. Seven-meter measurement location 1 is 7 meters (23 feet) from the generator (alternator) end of the generator set, and the locations proceed counter-clockwise around the generator set at 45° angles at a height of 1.2 meters (48 inches) above the ground surface.
3. Sound Power Levels are calculated according to ISO 3744, ISO 8528-10, and or CE (European Union) requirements.
4. Exhaust Sound Levels are measured and calculated per ISO 6798, Annex A.
5. Reference Sound Pressure Level is 20 µPa.
6. Reference Sound Power Level is 1 pW (10⁻¹² Watt).
7. Fan noise is not included for the configuration with remote cooling system. Fan noise is included for the configurations with a specific cooling system.
8. Sound data for the generator set with infinite exhaust do not include the exhaust noise contribution.
9. Published sound levels are measured at CE certified test site and are subject to instrumentation, measurement, installation and manufacturing variability.
10. Unhoused/Open configuration generator sets refers to generator sets with no sound enclosures of any kind.
11. Housed/Enclosed/Closed/Canopy configuration generator sets refer to generator sets that have noise reduction sound enclosures installed over the generator set and usually integrally attached to the skid base/base frame/fuel container base of the generator set.
12. Published sound levels meet the requirements India's Central Pollution Control Board (Ministry of Environment & Forests), vide GSR 371 (E), which states the A-weighted sound level at 1 meter from any diesel generator set up to a power output rating of 1000kVA shall not exceed 75dB(A)
13. For updated noise pollution information for India see website: <http://www.envfor.nic.in/legis/legis.html>
14. Sound levels must meet India's Ambient Air Noise Quality Standards detailed for Daytime/Night-time operation in Noise Pollution (Regulation and Control) Rules, 2000
15. Operator Location is near genset control panel and is at 1 meter distance from genset control panel and at 1.6 height.



Cooling System Data

C2000D6E

QSK50-G24

High Ambient Air Temperature Radiator Cooling System

| | Fuel Type | Duty | Rating (kW) | Max cooling @ air flow static restriction, unhooded (inches water/mm water) | | | | | Housed in free air, no air discharge restriction | | |
|-------|-----------|---------|-------------|-----------------------------------------------------------------------------|----------|----------|-----------|----------|--------------------------------------------------|--|--|
| | | | | 0.0/0.0 | 0.25/6.4 | 0.5/12.7 | 0.75/19.1 | 1.0/25.4 | Enclosed | | |
| | | | | Maximum allowable ambient temperature, degree C | | | | | | | |
| 60 Hz | Diesel | Standby | 2000 | 47.6 | 45.0 | 41.5 | 38.6 | 35.4 | N/A | | |
| | | Prime | 1825 | N/A | N/A | N/A | N/A | N/A | N/A | | |
| | | DCC | 1825 | N/A | N/A | N/A | N/A | N/A | N/A | | |
| | | | | Airflow (m ³ /s) – Actual @ Fan | | | | | | | |
| | | | | 36.3 | 35.4 | 34.6 | 33.4 | 32.4 | N/A | | |

Notes:

1. Data shown are anticipated cooling performance for typical generator set.
2. Cooling data is based on 1000 ft (305 m) site test location
3. Generator set power output may need to be reduced at high ambient conditions. Consult generator set data sheet for derate schedules.
4. Cooling performance may be reduced due to several factors including but not limited to: Incorrect installation, improper operation, fouling of the cooling system, and other site installation variables.



2024 EPA Tier 2 Exhaust Emission Compliance Statement C2000D6E Stationary Emergency 60 Hz Diesel Generator Set

Compliance Information:

The engine used in this generator set complies with Tier 2 emissions limit of U.S. EPA New Source Performance Standards for stationary emergency engines under the provisions of 40 CFR 60 Subpart IIII when tested per ISO8178 D2.

| | |
|-----------------------------------------------|------------------|
| Engine Manufacturer: | Cummins Inc. |
| EPA Certificate Number: | RCEXL050.AAD-016 |
| Effective Date: | 09/05/2023 |
| Date Issued: | 09/05/2023 |
| EPA Engine Family (Cummins Emissions Family): | RCEXL050.AAD |

Engine Information:

| | | | |
|--------------------------|------------------------------------|--------------------|--------------------------|
| Model: | QSK50-G24 | Bore: | 6.26 in. (159 mm) |
| Engine Nameplate HP: | 2956 | Stroke: | 6.26 in. (159 mm) |
| Type: | 4 cycle, Vee, 16 Cylinder Diesel | Displacement: | 3039 cu. in. (50 liters) |
| Aspiration: | Turbocharged and Charge Air Cooled | Compression Ratio: | 14.2:1 |
| Emission Control Device: | Turbocharged and Charge Air Cooled | | |

Diesel Fuel Emissions Limits

D2 Cycle Exhaust Emissions

| | Grams per BHP-hr | | | Grams per kW _m -hr | | |
|---------------------|------------------------------|-----------|-----------|-------------------------------|-----------|-----------|
| | <u>NO_x + NMHC</u> | <u>CO</u> | <u>PM</u> | <u>NO_x + NMHC</u> | <u>CO</u> | <u>PM</u> |
| EPA Emissions Limit | 4.7 | 2.6 | 0.15 | 6.4 | 3.5 | 0.20 |

Test methods: EPA emissions recorded per 40 CFR Part 60, 89, 1039, 1065 and weighted at load points prescribed in the regulations for constant speed engines.

Diesel fuel specifications: Cetane number: 40-50. Reference: ASTM D975 No. 2-D, 300-500 ppm Sulfur

Reference conditions: Air inlet temperature: 25°C (77°F), Fuel inlet temperature: 40°C (104°F). Barometric pressure: 100 kPa (29.53 in Hg), Humidity: 10.7 g/kg (75 grains H₂O/lb) of dry air; required for NO_x correction, Restrictions: Intake restriction set to a maximum allowable limit for clean filter; Exhaust back pressure set to a maximum allowable limit.

Tests conducted using alternate test methods, instrumentation, fuel or reference conditions can yield different results. Engine operation with excessive air intake or exhaust restriction beyond published maximum limits, or with improper maintenance, may result in elevated emission levels.



Exhaust Emission Data Sheet

C2000D6E

60 Hz Diesel Generator Set

Engine Information:

| | | | |
|--------------------|------------------------------------|---------------|----------------------------|
| Model: | Cummins Inc. QSK50-G24 | Bore: | 6.26 in. (159 mm) |
| Type: | 4 Cycle, Vee, 16-cylinder Diesel | Stroke: | 6.26 in. (159 mm) |
| Aspiration: | Turbocharged and Charge Air Cooled | Displacement: | 3039 cu. in. (49.8 liters) |
| Compression Ratio: | 14.2:1 | | |

| <u>Performance Data</u> | <u>1/4</u> <u>Standby</u> | <u>1/2</u> <u>Standby</u> | <u>3/4</u> <u>Standby</u> | <u>Full</u> <u>Standby</u> | <u>Full</u> <u>Prime</u> | <u>Full</u> <u>DCC</u> |
|-------------------------------|------------------------------|------------------------------|------------------------------|-------------------------------|-----------------------------|---------------------------|
| Engine BHP @ 1800 RPM (60 Hz) | 739 | 1478 | 2217 | 2956 | 2648 | 2648 |
| Fuel Consumption (US Gal/Hr) | 41.5 | 73.7 | 112.0 | 139.8 | 128.0 | 128.0 |
| Exhaust Gas Flow (CFM) | 6229 | 9733 | 13648 | 15388 | 15654 | 14654 |
| Exhaust Gas Temperature (°F) | 650 | 696 | 894 | 996 | 954 | 954 |
| Air to Fuel Ratio | 42:1 | 36:1 | 29:1 | 24:1 | 26:1 | 26:1 |

Exhaust Emission Data

| | | | | | | |
|----------------------------------------------|------|------|------|------|------|------|
| HC (Total Unburned Hydrocarbons) | 0.15 | 0.07 | 0.04 | 0.03 | 0.03 | 0.03 |
| NOx (Oxides of Nitrogen as NO ₂) | 2.8 | 3.9 | 3.9 | 6.7 | 5.4 | 5.4 |
| CO (Carbon Monoxide) | 1.13 | 0.33 | 0.35 | 0.31 | 0.31 | 0.31 |
| PM (Particulate Matter) | 0.05 | 0.05 | 0.04 | 0.01 | 0.02 | 0.02 |
| SO ₂ (Sulfur Dioxide) | 0.13 | 0.11 | 0.12 | 0.10 | 0.11 | 0.11 |
| Smoke (Bosch) | 0.2 | 0.3 | 0.2 | 0.1 | 0.2 | 0.2 |

(All values are cited: g/HP-hr)

Test Conditions

Steady-state emissions recorded per ISO8178-1 during operation at rated engine speed (+/-2%) and stated constant load (+/-2%) with engine temperatures, pressures and emission rates stabilized.

| | |
|-------------------------|----------------------------------------------------------------------------------------|
| Fuel Specification: | ASTM D975 No. 2-D S15 diesel fuel with 0.0015 Wt.% Sulfur content, 42-48 Cetane Number |
| Air Inlet Temperature | 25 °C (77 °F) |
| Fuel Inlet Temperature: | 40 °C (104 °F) |
| Barometric Pressure: | 100 kPa (29.53 in Hg) |
| Humidity: | NOx measurement corrected to 10.7 g/kg (75 grains H ₂ O/lb) of dry air |
| Intake Restriction: | Set to 18 in of H ₂ O as measured from compressor inlet |
| Exhaust Back Pressure: | Set to 1.5 in Hg |

Note: mg/m³ values are measured dry, corrected to 5% O₂ and normalized to standard temperature and pressure (0°C, 101.325 kPa)

The NOx, HC, CO and PM emission data tabulated here are representative of test data taken from a single engine under the test conditions shown above. Data for the other components are estimated. These data are subjected to instrumentation and engine-to-engine variability. Field emission test data are not guaranteed to these levels. Actual field test results may vary due to test site conditions, installation, fuel specification, test procedures and instrumentation. Engine operation with excessive air intake or exhaust restriction beyond published maximum limits, or with improper maintenance, may result in elevated emission levels.



Prototype Test Support (PTS) 60 Hz test summary



| <u>Generator set models</u> | <u>Representative prototype</u> |
|-----------------------------|---------------------------------|
| C1750D6E | Model: C2000D6E |
| C2000D6E | Engine: QSK50-G24 |
| | Alternator: S9H1D-D4 |

The following summarizes prototype testing conducted on the designated representative prototype of the specified models. This testing is conducted to verify the complete generator set electrical and mechanical design integrity. Prototype testing is conducted only on generator sets not sold as new equipment.

Maximum surge power: 2036 kW
The generator set was evaluated to determine the stated maximum surge power.

Maximum motor starting: 5200 kVA
The generator set was tested to simulate motor starting by applying the specified kVA load at low lagging power factor (0.4 or lower). With this load applied, the generator set recovered to a minimum of 90% rated voltage.

Alternator temperature rise:
The highest rated temperature rise (150 °C) test result are reported as follows to verify that worst case temperature rises do not exceed allowable NEMA MG1 limits for class H insulation. Tests were conducted per IEEE 115, rise by resistance and embedded detector, with rated voltages. Only the highest temperatures are reported.

| Location | Maximum Rise (°C) |
|--------------------|-------------------|
| Alternator Stator: | 150 |
| Alternator Rotor: | 150 |
| Exciter Stator: | 150 |
| Exciter Rotor: | 150 |

Torsional analysis and testing:
The generator set on S9H1D-D4 was tested to verify that the design is not subjected to harmful torsional stresses. A spectrum analysis of the transducer output was conducted over the speed range of 1650 to 1950 RPM.

Cooling system: 40°C ambient
0.5 in H2O restriction

The cooling system was tested to determine ambient temperature and static restriction capabilities. The test was performed at full rated load elevated ambient temperature under static restriction conditions.

Durability:
The generator set was subjected to 360 hour of endurance testing replicating field duty cycles operating at variable load up to the standby rating based on MIL-STD-705 to verify structural soundness and durability of the design.

Electrical and mechanical strength:
The generator set was tested to several single phase and three phase faults to verify that the generator can safely withstand the forces associated with short circuit conditions. The generator set was capable of producing full rated output at the conclusion of the testing.

Steady state performance:
The generator set was tested to verify steady state operating performance. It was within the specified maximum limits.

| | |
|-----------------------------|-------------|
| Voltage regulation: | ± 0.32% |
| Random voltage variation: | ± 0.41% |
| Frequency regulation: | Isochronous |
| Random frequency variation: | ± 0.06% |

Transient performance:
The generator set was tested with the listed alternator to verify single step loading capability as required by NFPA 110. Voltage and frequency response on load addition or rejection were evaluated. The following results were recorded at 1.0 power factor:

Full load acceptance:

| | |
|----------------|-------------|
| Voltage dip: | 46.6% |
| Recovery time: | 3.6 seconds |
| Frequency dip: | 16.9% |
| Recovery time: | 4.4 seconds |

Full load rejection:

| | |
|-----------------|-------------|
| Voltage rise: | 4.6% |
| Recovery time: | 0.3 seconds |
| Frequency rise: | 4.9% |
| Recovery time: | 0.8 seconds |

All data based on 1.0 power factor:

Harmonic analysis:
(per MIL-STD-705B, Method 601.4)

| <u>Harmonic</u> | <u>Line to Line</u> | | <u>Line to Neutral</u> | |
|-----------------|---------------------|------------------|------------------------|------------------|
| | <u>No load</u> | <u>Full load</u> | <u>No load</u> | <u>Full load</u> |
| 3 | 0.03 | 0.06 | 0.05 | 0.10 |
| 5 | 0.97 | 0.99 | 0.98 | 0.97 |
| 7 | 1.02 | 0.42 | 1.01 | 0.43 |
| 9 | 0.01 | 0.01 | 0.01 | 0.01 |
| 11 | 0.05 | 0.43 | 0.06 | 0.43 |
| 13 | 0.17 | 0.32 | 0.17 | 0.31 |
| 15 | 0.01 | 0.01 | 0.01 | 0.03 |

SECTION 3
GENERATOR ACCESSORIES



Data Sheet

Circuit Breakers



Description

This data sheet provides circuit breaker manufacturer part numbers and specifications. The circuit breaker box description is the rating of that breaker box installation on a Cummins® generator. Please refer to the website of the circuit breaker manufacturer for breaker specific ratings and technical information.

Applicable Models

| Engine | Models | | | |
|-----------|----------|----------|-------|-------|
| QSK23-G7 | DQCA | DQCB | DQCC | |
| QST30-G5 | DQFAA | DQFAB | DQFAC | DQFAD |
| QST30-G17 | DQFAH | | | |
| QSK38-G17 | C1250D6E | | | |
| QSK38-G18 | C1250D6E | C1500D6E | | |
| QSK50-G5 | DQGAE | DQGAF | | |
| QSK50-G4 | DQGAA | DQGAB | | |
| QSK50-G8 | DQGAS | | | |
| QSK50-G24 | C1750D6E | C2000D6E | | |
| QSK50-G25 | C2000D6E | | | |
| QSK60-G6 | DQKAA | DQKAB | DQKAD | DQKAE |
| QSK60-G14 | DQKAF | | | |
| QSK60-G17 | DQKAM | | | |

Instructions

1. Locate the circuit breaker feature code or part number and use the charts below to find the corresponding manufacturer circuit breaker catalog number.

2. Use the first letter of the circuit breaker catalog number to determine the "frame" of the breaker. If the first letter is an "N", use the second letter. Then follow the corresponding website link from the table below to find the breaker catalog number description.

Please refer to the catalog numbering systems page, which is given in the chart, to understand the nomenclature of the catalog number.

| Frame | Catalog Name* | Catalog Number Description Pages |
|---------------------|-------------------------------------------------------------------------------------------------------------------------------------------|-------------------------------------|
| P and R | 0612CT0101 https://www.se.com/us/en/download/document/0612CT0101/ | 16-17 |
| L | 0611CT1001 https://www.se.com/us/en/download/document/0611CT1001/ | 8-9 |
| MasterPact NT/NW | https://www.se.com/us/en/faqs/FA231180/ | Please refer to PLS007 Rev 25 |

*The following link may also be used to search specifically by the breaker part number or for the catalog name listed above.

<https://www.se.com/us/en/work/support/contacts.jsp>

3. Search the catalog by using the first 3 letters of the breaker catalog number and the first 5 numbers to find information such as trip curves, accessories, and dimensional details regarding the circuit breaker.

*If the catalog number starts with "N", skip the N and begin your search with the second letter.

*If the first 3 letters are "PJP," the search will not work. You will need to start with just "PJ" and use the description pages to obtain the information you are looking for on the "PJP."

Example

After finding your circuit breaker catalog number to be "PJL36120U33EACUKMOYB," navigate to the P-frame catalog by using the link provided.

Look at pages 16-17 of the pdf catalog to find the nomenclature of the breaker.

Search the P-frame spec sheet using the search "PJL36120."

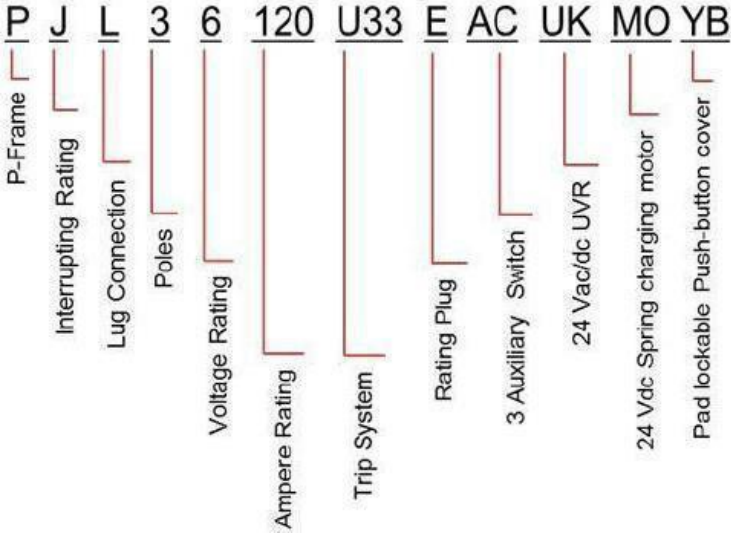

For decoding the ABB breakers, see the decoder sheet, titled "T8 Catalog number explanation"

| | | | | | | | |
|--------|--------------------------------------------------------|-----------|-------------------------------------------------------------------------------------------------------------|--------------------|--------------------|---------------------|-----|
| KP91-2 | CB-800A, Left, 3P, UL 600, IEC 415, UL Serv Ent, 100% | 0320-2182 | QSK50-G4, QSK50-G5, QSK50-G7, QSK60-G6, QSK60-G11, QSK60-G14, QSK60-G18 | Schneider Electric | PJP36080U31F | MicroLogic 3.0 LI | F |
| | | A054K405 | QST30-G5, QST30-G17, 30L QSK23-G7 | | PJP36080U33F | MicroLogic 5.0 LSI | |
| KP92-2 | CB-600A, Right, 3P, UL 600, IEC 690, UL Serv Ent 100% | A044T468 | QSK23-G7, QST30-G5, QST30-G17, 30L, QSK50-G4, QSK50-G5, QSK50-G7, QSK60-G6, QSK60-G11, QSK60-G14, QSK60-G18 | Schneider Electric | NLGL36600U33X-600A | MicroLogic 3.3S LSI | N/A |
| | | A065A765 | QSK50-G24, QSK50-G25 | | | | |
| | | A065A801 | QSK50-G24, QSK50-G25 | | | | |
| KP93-2 | CB-600A, Left, 3P, UL 600, IEC 690, UL Serv Ent, 100% | A044T468 | QSK23-G7, QST30-G5, QST30-G17, 30L, QSK50-G4, QSK50-G5, QSK50-G7, QSK60-G6, QSK60-G11, QSK60-G14, QSK60-G18 | Schneider Electric | NLGL36600U33X-600A | MicroLogic 3.3S LSI | N/A |
| | | A065A765 | QSK50-G24, QSK50-G25 | | | | |
| | | A065A801 | QSK50-G24, QSK50-G25 | | | | |
| KU62-2 | CB-3000A, 3P, 600/690V, UL/IEC, ServEnt, 100%UL, Right | A029B150 | QSK38-G17, QSK38-G18, QSK50-G5, QSK50-G7, QSK60-G6, QSK60-G11, QSK60-G14, QSK60-G18, QSK50-G24, QSK50-G25 | Schneider Electric | RLF36300U31A | MicroLogic 3.0 LI | A |
| | | A064G469 | QSK50-G24, QSK50-G25 | | | | |
| KU68-2 | CB-3000A, 3P, 600/690V, UL/IEC, ServEnt, 100%UL, Left | A029B150 | QSK38-G17, QSK38-G18, QSK50-G5, QSK50-G7, QSK60-G6, QSK60-G11, QSK60-G14, QSK60-G18 | Schneider Electric | RLF36300U31A | MicroLogic 3.0 LI | A |
| M696-2 | Right Side Circuit Breaker - 1000A | A065A771 | QSK38-G17, QSK38-G18, QSK50-G24, QSK50-G25 | Schneider Electric | PJF36100U33A | MicroLogic 5.0 LSI | A |
| | | A065A803 | QSK50-G24, QSK50-G25 | | | | |
| M690-2 | Left Side Circuit Breaker - 1000A | A065A771 | QSK38-G17, QSK38-G18 | Schneider Electric | PJF36100U33A | MicroLogic 5.0 LSI | A |

T8 Catalog Number Explanation

T 8 V

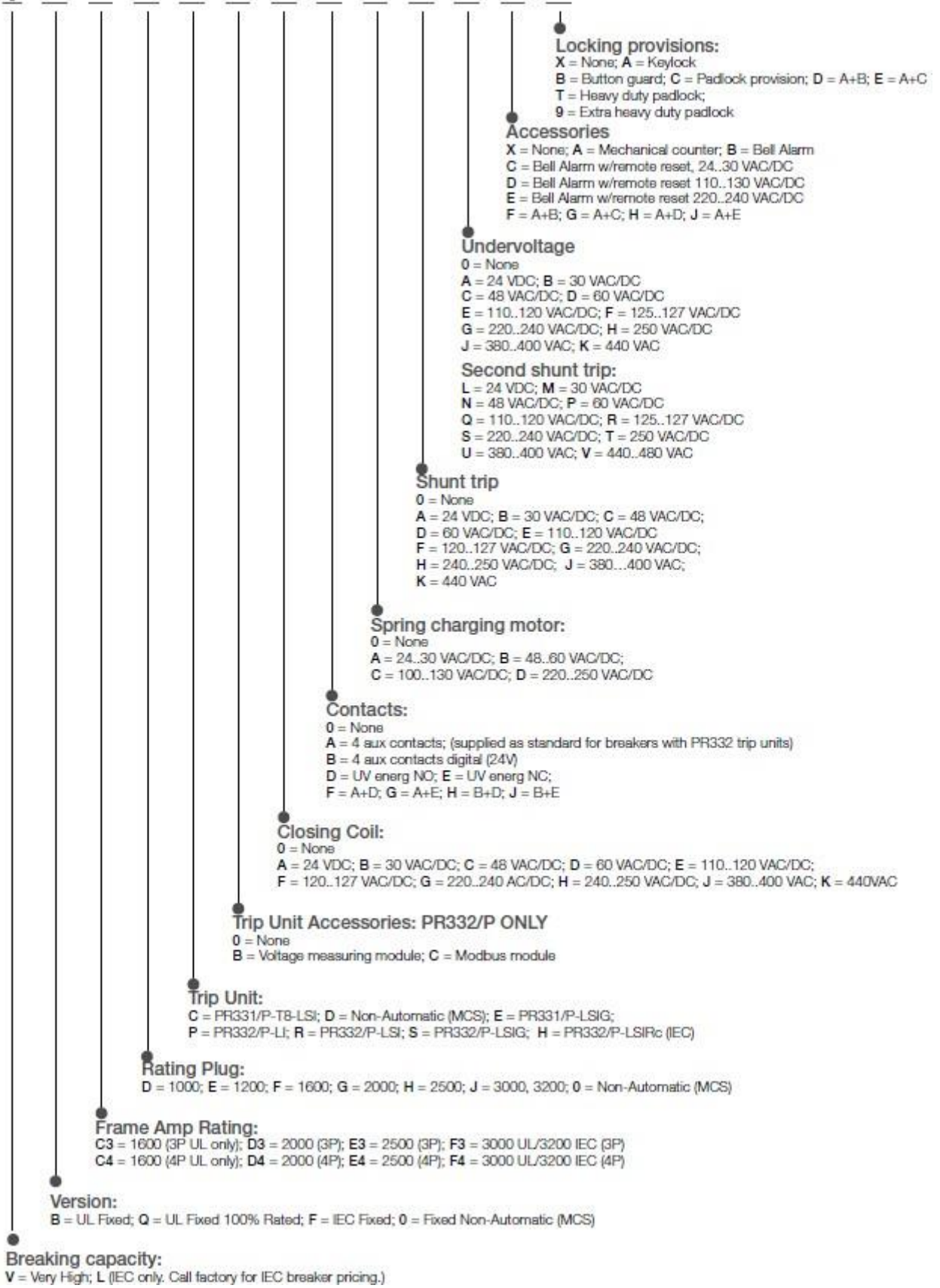

Product data sheet

Specifications

SQUARE D

Green Premium™



POWERPACT R-FRAME, MOLDED CASE CIRCUIT BREAKER, 600V, 3000A, 3P, 50kA

RLF36300U31A

Main

| | |
|---------------------------|-----------------|
| Range | PowerPact |
| Product name | PowerPact R |
| Product or Component Type | Circuit breaker |
| Device application | Distribution |

Complementary

| | |
|----------------------------------------|-------------------------------------------------------------------------------------------------------------------------------------------------------------------------------------------------------------|
| Line Rated Current | 3000 A |
| Number of Poles | 3P |
| Control type | Operating handle |
| Breaking capacity code | L |
| Breaking capacity | AIR 125 kA 240 V AC 50/60 Hz UL 489 AIR 100 kA 480 V AC 50/60 Hz UL 489 AIR 50 kA 600 V AC 50/60 Hz UL 489 Icu 125 kA 240 V AC 50/60 Hz IEC 60947-2 Icu 85 kA 380/415 V AC 50/60 Hz IEC 60947-2 |
| [Ue] rated operational voltage | 600 V AC 50/60 Hz UL 489 |
| Network Frequency | 50/60 Hz |
| [Ics] rated service breaking capacity | 65 kA 240 V AC 50/60 Hz IEC 60947-2 45 kA 380/415 V AC 50/60 Hz IEC 60947-2 |
| [Uimp] rated impulse withstand voltage | 8 kV IEC 60947-2 |
| Trip unit technology | Electronic, standard, Micrologic 3.0, LI |
| [Ui] rated insulation voltage | 750 V IEC 60947-2 |
| Trip unit name | Micrologic 3.0 |
| Suitability for isolation | Yes IEC 60947-2 |
| Utilisation category | Category A |
| AWG gauge | Please see CB outline drawing for lug and termination details |
| Local signalling | Alarm 1 LED yellow)long-time pick up) |
| Mounting mode | Unit mount busbar) |
| Mounting Support | Busbar |

| | |
|------------------------------------|----------------------------------------------------------------------------------------------------------------------------------------------------------------------------------------------------------------------|
| Electrical connection | Busbar connection line Busbar connection load |
| Terminal identifier | Please see CB outline drawing for lug and termination details |
| Tightening torque | 548.75 lbf.in (62 N.m) 0.08...0.62 in ² (50...400 mm ²) (AWG 1/0...750 kcmil) 548.75 lbf.in (62 N.m) 0.08...0.23 in ² (50...150 mm ²) (2 x AWG 1/0...2 x 300 kcmil) |
| Number of slots | 2 auxiliary switch OF plug-in) 1 alarm switch SD plug-in) 1 voltage release MN or MX plug-in) |
| Power wire stripping length | 1.38 in (35 mm) |
| Height | 16.24 in (412.50 mm) |
| Width | 16.54 in (420.12 mm) |
| Depth | 14.49 in (368.05 mm) |
| Net Weight | 52 lb(US) (23.59 kg) |
| Quantity per Set | 1 |

Environment

| | |
|----------------------------------------------|------------------------------------------------------------------------------|
| Quality labels | CE |
| Standards | UL CSA NEMA NMX J-266 IEC 60947-2 |
| Product certifications | UL CSA NOM |
| IP degree of protection | IP40 |
| Pollution degree | 3 IEC 60947-1 |
| Ambient Air Temperature for Operation | -13...158 °F (-25...70 °C) |
| Ambient Air Temperature for Storage | -58...185 °F (-50...85 °C) |
| Operating altitude | < 6561.68 ft (2000 m) without derating 13123.36 ft (4000 m) with derating |

Ordering and shipping details

| | |
|----------------------------|-------------------------------------|
| Category | 01245-RG,H,J,K,L,N UNIT MT BREAKERS |
| Discount Schedule | DE2 |
| Package weight(Lbs) | 75.00 lb(US) (34.019 kg) |
| Returnability | Yes |
| Country of origin | US |

Offer Sustainability

| | |
|-----------------------------------|------------------------------------------------------------------------------------------------------------------------------------------------------------------------------------------------------------------------------------------------------------------------------------------------------------------------------------|
| Sustainable offer status | Green Premium product |
| California proposition 65 | WARNING: This product can expose you to chemicals including: DINP, which is known to the State of California to cause cancer, and DIDP, which is known to the State of California to cause birth defects or other reproductive harm. For more information go to www.P65Warnings.ca.gov |
| REACH Regulation | REACH Declaration |
| EU RoHS Directive | Compliant EU RoHS Declaration |
| Mercury free | Yes |
| RoHS exemption information | Yes |
| China RoHS Regulation | China RoHS declaration Product out of China RoHS scope. Substance declaration for your information. |

| | |
|------------------------------------|-----------------------------------------------|
| Environmental Disclosure | Product Environmental Profile |
| Circularity Profile | End of Life Information |
| PVC free | Yes |
| Halogen content performance | Halogen free plastic parts product |

Micrologic™ 3.0 Electronic Trip Unit

Instruction Bulletin

48049-207-05

Rev. 01, 07/2012

Retain for future use.



Section 1—General Information

Introduction

Micrologic™ trip units (A) provide adjustable tripping functions on electronic trip circuit breakers. The product name (B) specifies the level of protection provided by the trip unit.

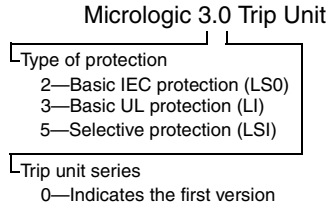

Micrologic trip units are field replaceable to allow for upgrading of the trip unit in the field. For complete information on available circuit breaker models, frame sizes, interrupting ratings, sensor plugs, rating plugs and trip units, see the product catalog.

Trip Unit Settings

Figure 1: Micrologic Trip Unit

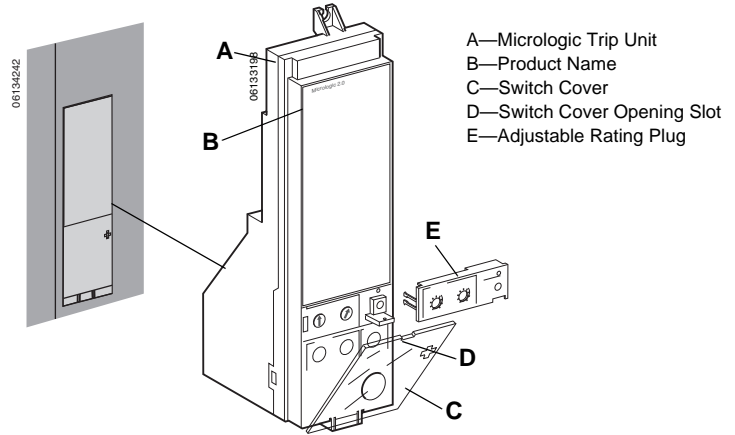

On the face of the trip unit are adjustable switches to allow changing of trip characteristics. Trip units are shipped with the long-time pickup switch set at 1.0 and all other trip unit adjustments set at their lowest settings.

Micrologic 3.0 Trip Unit

The Micrologic 3.0 trip unit provides basic (LI) protection.

- A. Long-time pickup (I_r) switch
- B. Long-time delay (t_r) switch
- C. Instantaneous pickup (I_i) switch
- D. Test plug receptacle
- E. Overload indicator light
- F. Trip unit name

Figure 3: Micrologic 3.0 Trip Unit

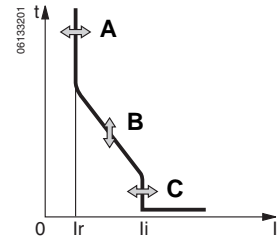
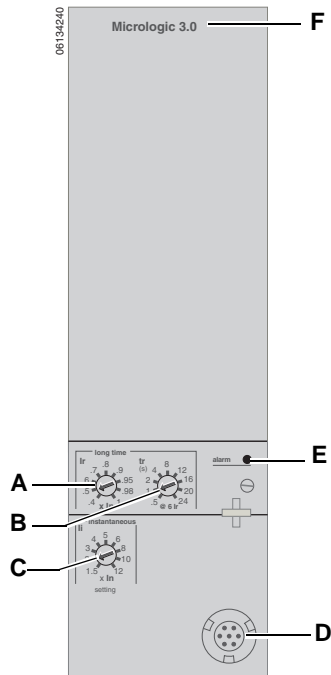

Trip Unit Switches

Long-Time Protection

Long-time protection protects equipment against overloads.

- Long-time protection is standard on all trip units.
- The long-time pickup (I_r) (A) sets maximum current level (based on sensor plug rating I_n) which circuit breaker will carry continuously. If current exceeds this value, circuit breaker will trip after the preset time delay. The long-time pickup (I_r) is adjustable from 0.4–1.0 times the sensor plug rating (I_n).
- The long-time delay (t_r) (B) sets the length of time that the circuit breaker will carry an overcurrent below the short-time or instantaneous pickup current level before tripping. See Table 1 for long-time delay settings.
- The overload indicator light (C) indicates that the I_r long-time pickup threshold has been exceeded.
- Both long-time pickup and long-time delay are on the field-replaceable adjustable rating plug. To change settings to more precisely match the application, various rating plugs are available. For instructions on replacing the rating plug, see Section 4—Adjustable Rating Plug Replacement.
- The I_n value can be changed by replacing the sensor plug below the trip unit. For further information, see the instructions packed with the sensor plug replacement kit.
- Long-time protection uses true RMS measurement.

Thermal imaging provides continuous temperature rise status of the wiring, both before and after the device trips. This allows the circuit breaker to respond to a series of overload conditions which could cause conductor overheating, but would go undetected if the long-time circuit was cleared every time the load dropped below the pickup setting or after every tripping event.

NOTE: If checking trip times, wait a minimum of 15 minutes after circuit breaker trips before resetting to allow the thermal imaging to reset completely to zero.

Figure 5: Long-Time Protection Switches

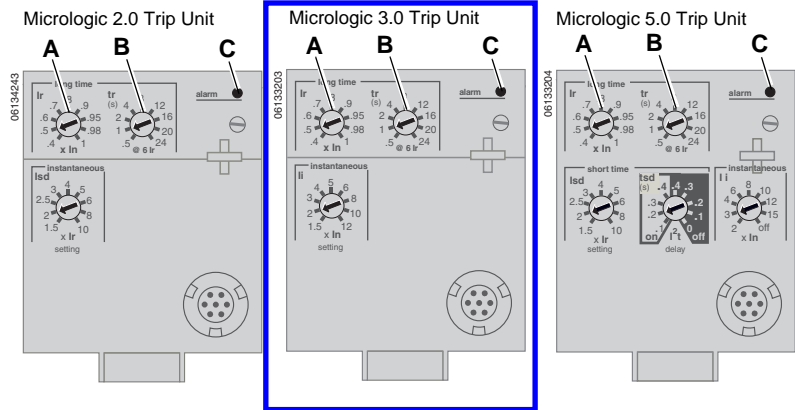

Table 1: Micrologic Trip Unit Long-Time Delay Values

| Setting ¹ | Long-Time Delay in Seconds ² | | | | | | | | |
|----------------------|-----------------------------------------|------|------|-----|-----|-----|-----|------|------|
| tr at 1.5 x Ir | 12.5 | 25 | 50 | 100 | 200 | 300 | 400 | 500 | 600 |
| tr at 6 x Ir | 0.5 | 1 | 2 | 4 | 8 | 12 | 16 | 20 | 24 |
| tr at 7.2 x Ir | 0.34 ³ | 0.69 | 1.38 | 2.7 | 5.5 | 8.3 | 11 | 13.8 | 16.6 |

¹ I_n = sensor rating. I_r = I_n x long-time pickup. Trip threshold between 1.05 and 1.20 I_r .

²Time-delay accuracy +0/-20%

³For Micrologic 5.0 trip units, when tsd is set to 0.4 off or 0.4 on, then t_r = 0.5 instead of 0.34.

Instantaneous Protection

Instantaneous protection protects equipment against short circuits with no intentional time delay.

- Instantaneous protection (li) (A) is standard on 3.0 and 5.0 trip units.*
- Instantaneous protection for 2.0 trip units is based on the circuit breaker sensor rating (Ir).
- Instantaneous protection for 3.0 and 5.0 trip units is based on the long-time delay pickup (In).
- Circuit breaker open command is issued as soon as threshold current is exceeded.
- Instantaneous protection for 3.0 and 5.0 trip units use peak current measurement. Instantaneous protection for 2.0 trip units use RMS current measurement.
- When instantaneous protection switch is set to off, the instantaneous protection is disabled.

*Instantaneous protection on 2.0 trip units is achieved by using short-time protection (Isd) with short-time delay factory set to 0 (zero).

Figure 7: Instantaneous Protection Switches

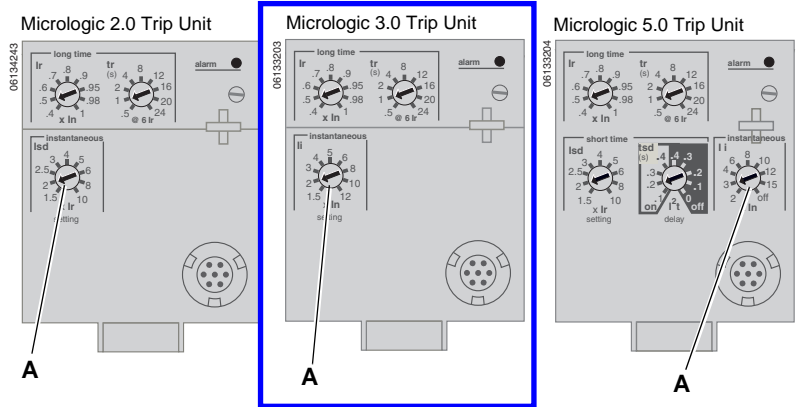

Table 3: Micrologic Instantaneous Values

| Setting | Interruption Current | | | | | | | | |
|--------------------|----------------------|---|-----|---|---|----|----|----|-----|
| 2.0 Isd (= Ir x..) | 1.5 | 2 | 2.5 | 3 | 4 | 5 | 6 | 8 | 10 |
| 3.0 li (= In x..) | 1.5 | 2 | 3 | 4 | 5 | 6 | 8 | 10 | 12 |
| 5.0 li (= In x..) | 2 | 3 | 4 | 6 | 8 | 10 | 12 | 15 | off |

li = UL and ANSI instantaneous
Isd = IEC instantaneous (short-time with zero delay)
In = sensor rating
Ir = long-time pickup

Overload Indicator Light

The overload indicator light (A) lights when the Ir long-time pickup level has been exceeded.

Figure 8: Overload Indicator Lights

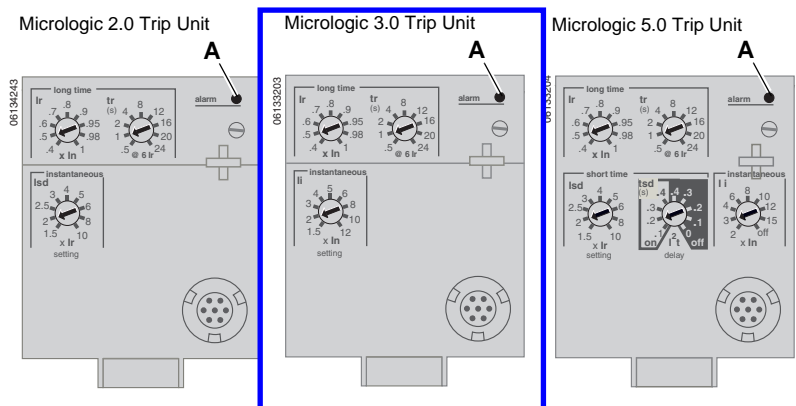

Trip Unit Testing

Trip unit functions can be tested using primary injection testing or secondary injection testing.

Section 2—Operation

Switch Adjustment

1. Open switch cover (A).
2. Adjust the appropriate switches (B) to desired values.
3. Replace switch cover. Use wire seal MICROTUSEAL (C), if necessary, to provide tamper evidence.

Figure 9: Adjust Switch Settings

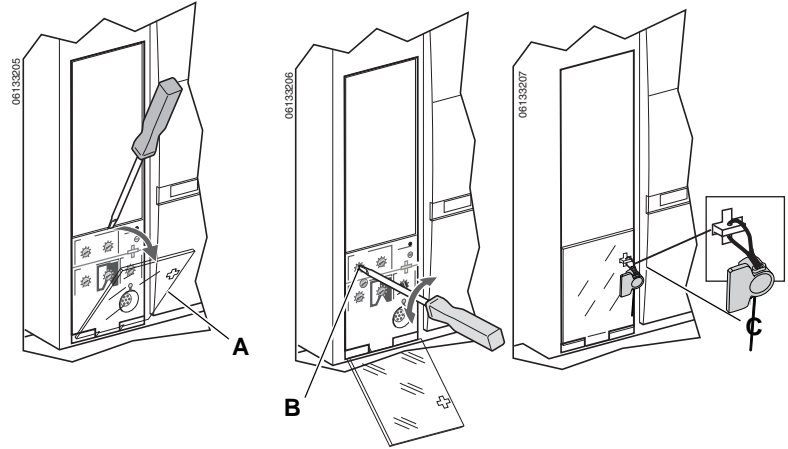

Examples

Circuit breaker is rated 2000 A.

Figure 10: Circuit Breaker Rating

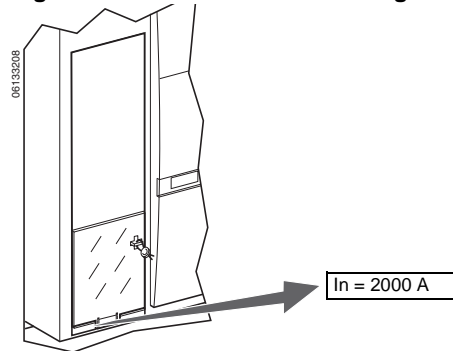

Micrologic 3.0 Trip Unit

1. Set pickup levels.

Figure 13: Set Pickup Levels

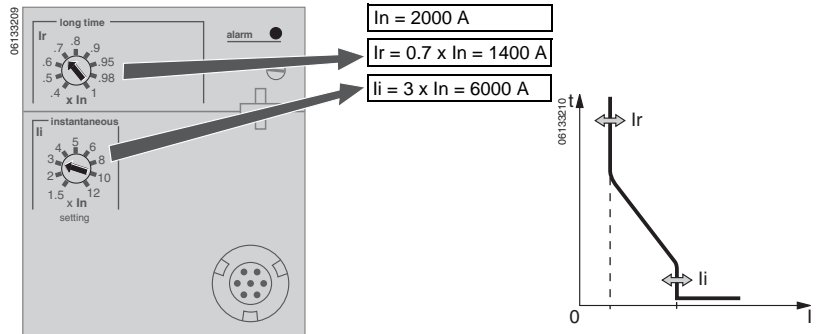

2. Set time delay.

Figure 14: Set Time Delay

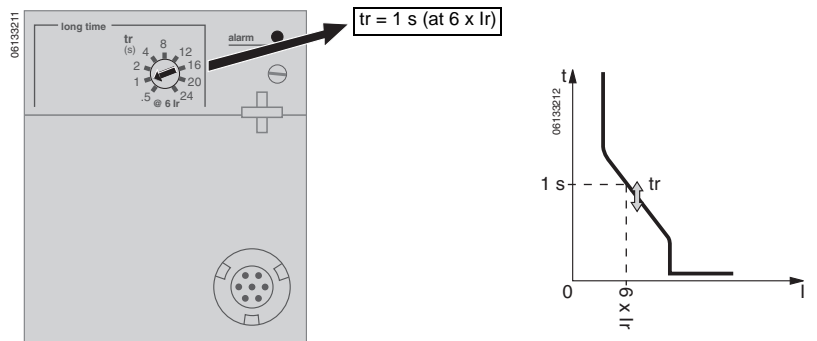

Trip Unit Operation Verification

Use a test kit connected to the trip unit test plug receptacle (A) to verify trip unit is functioning as desired. See instructions shipped with test kit to perform verification tests.

Figure 17: Verify Trip Unit Operation

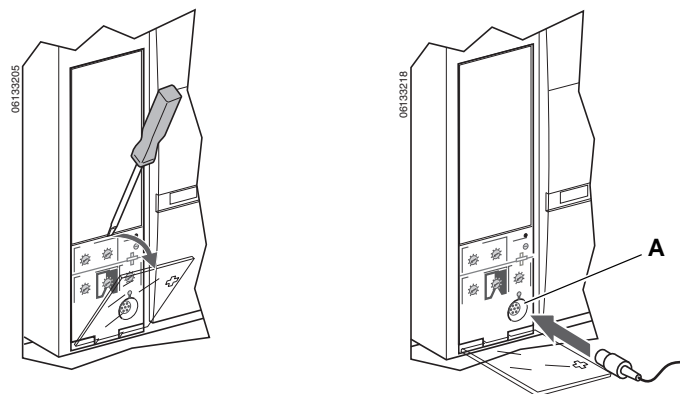

CURRENT IN MULTIPLES OF I_r ($I_r = \text{LONG-TIME SETTING} \times I_n$)

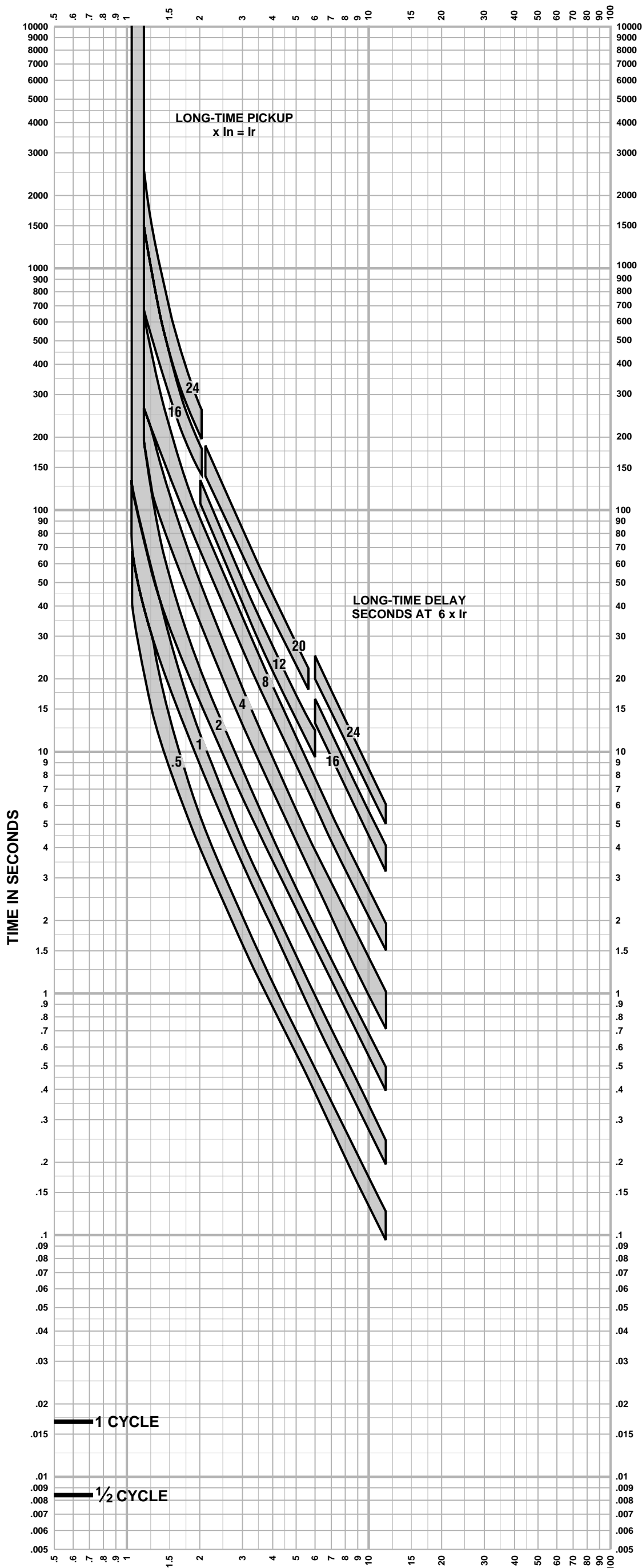

CURRENT IN MULTIPLES OF I_r
($I_r = \text{LONG-TIME SETTING} \times I_n$)

- Merlin Gerin
- Modicon
- Square D
- Telemecanique
- Federal Pioneer
- Federal Pacific

Schneider Electric Brands

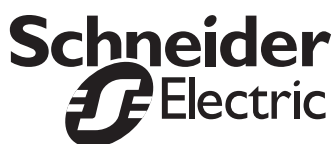

© 2000 Schneider Electric all rights reserved

**MICROLOGIC® 3.0 A TRIP UNIT
CHARACTERISTIC TRIP CURVE NO. 613-6**

Long-time Pickup and Delay

The time-current curve information is to be used for application and coordination purposes only.

Curves apply from -30°C to +60°C ambient temperature.

Notes:

1. There is a thermal-imaging effect that can act to shorten the long-time delay. The thermal-imaging effect comes into play if a current above the long-time delay pickup value exists for a time and then is cleared by the tripping of a downstream device or the circuit breaker itself. A subsequent overload will cause the circuit breaker to trip in a shorter time than normal. The amount of time delay reduction is inverse to the amount of time that has elapsed since the previous overload. Approximately 20 minutes is required between overloads to completely reset thermal-imaging.
2. The end of the curve is determined by the instantaneous setting.
3. Total clearing times shown include the response times of the trip unit, the circuit breaker opening, and the extinction of the current.
4. See 613-8 for instantaneous pickup trip curve.

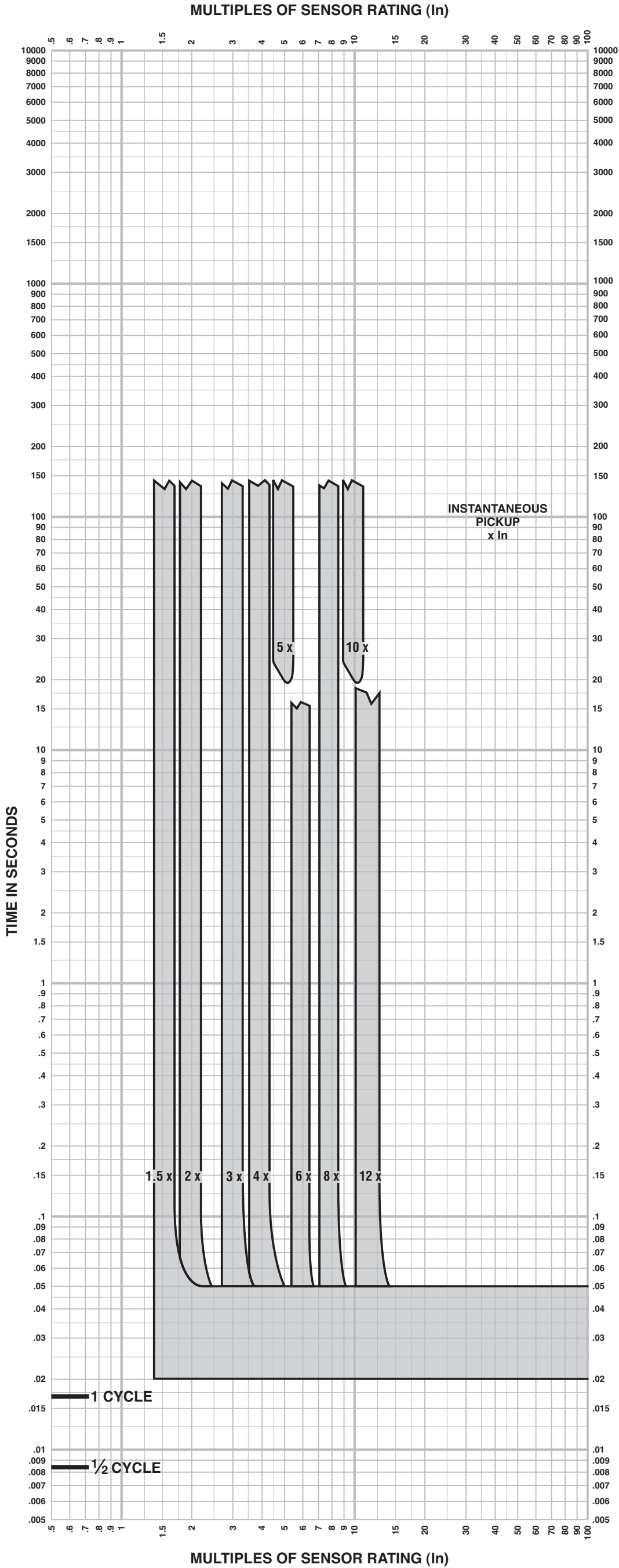
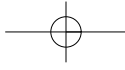

**MICROLOGIC® 3.0 A TRIP UNIT
CHARACTERISTIC TRIP CURVE NO. 613-8**

Instantaneous Pickup
1.5x-12x

The time-current curve information is to be used for application and coordination purposes only.

Curves apply from -30° to +60°C ambient temperature.

Instantaneous override values are given on 613-10.

Notes:

1. The end of the curve is determined by the interrupting rating of the circuit breaker.
2. Total clearing times shown include the response times of the trip unit, the circuit breaker opening, and the extinction of the current.
3. The instantaneous region of the trip curve shows maximum total clearing times. Actual clearing times in this region can vary depending on the circuit breaker mechanism design and other factors. The actual clearing time can be considerably faster than indicated. Contact your local Sales Office for additional information.
4. See 613-6 for long-time pickup and delay trip curves.



Merlin Gerin
Square D
Telemecanique

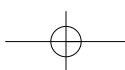
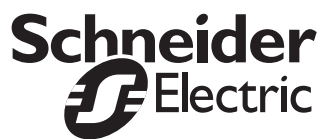

SECTION 4

GENERATOR DRAWINGS AND INTERCONNECTS



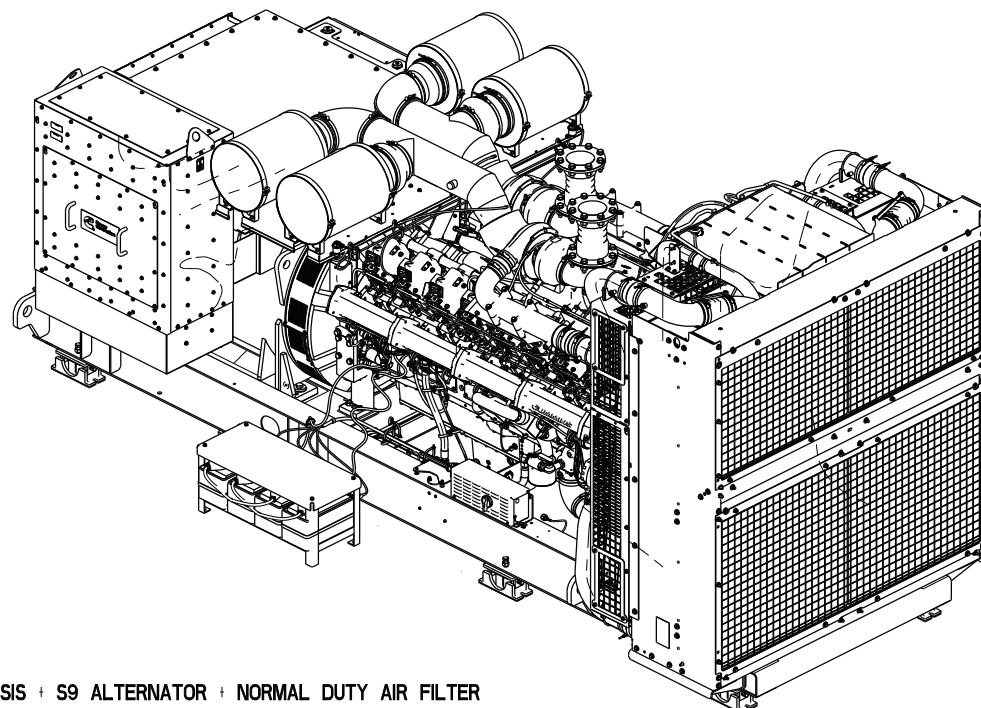
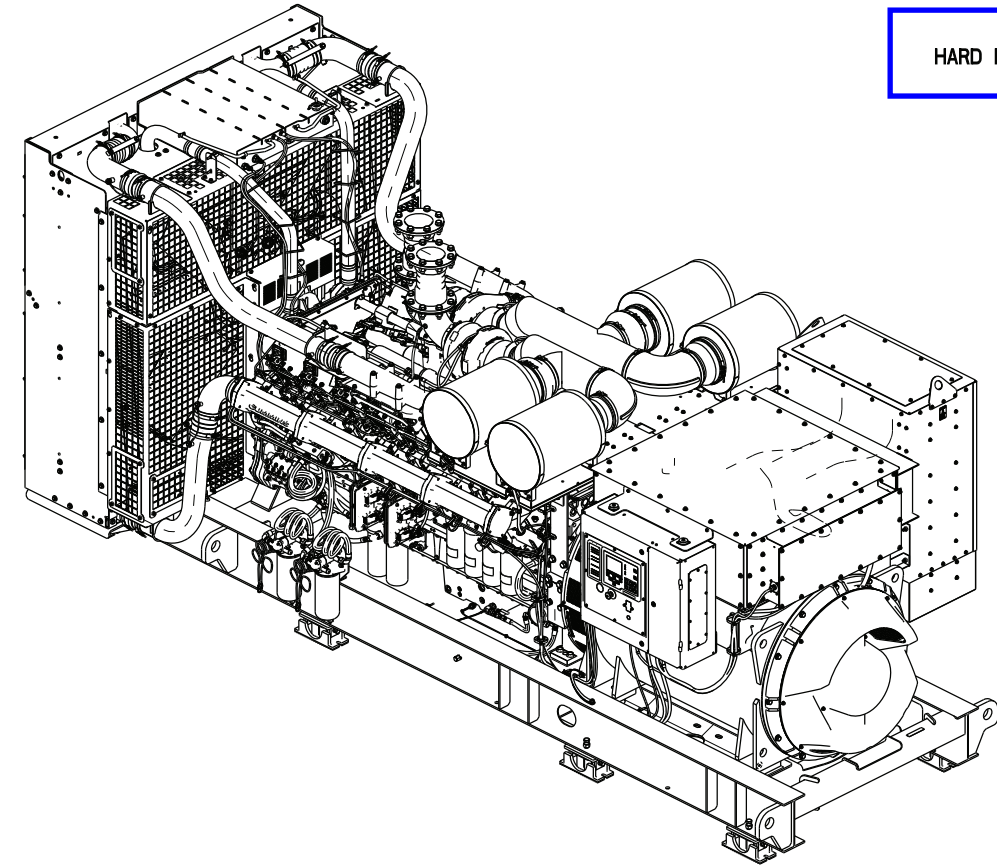
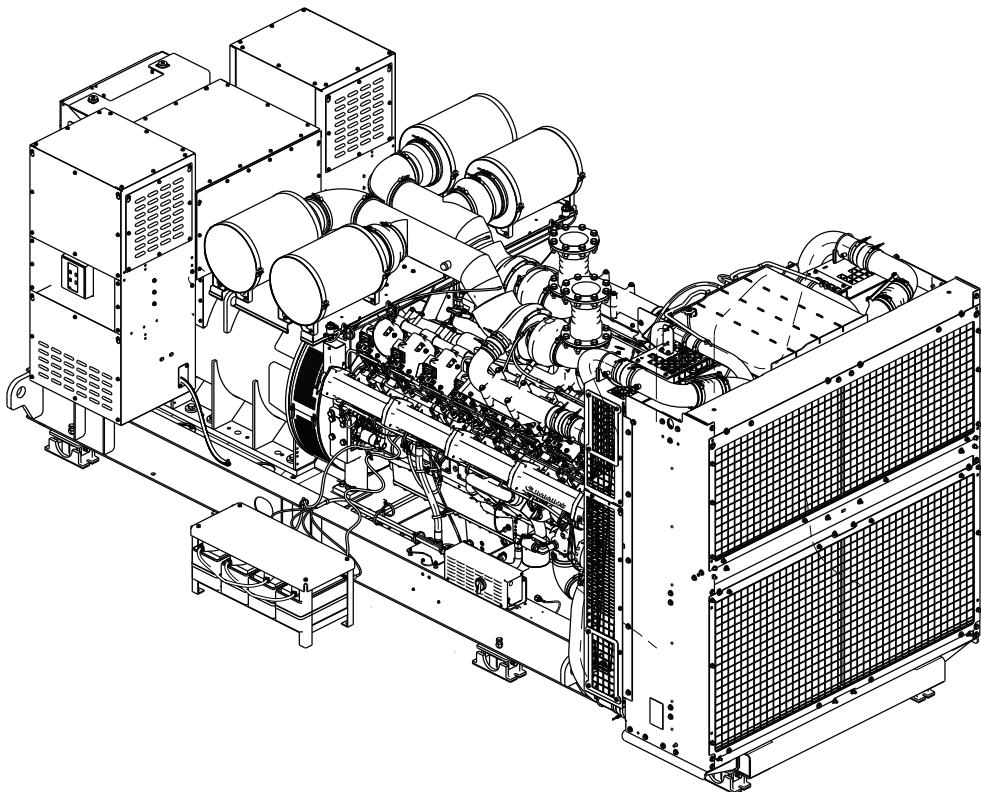
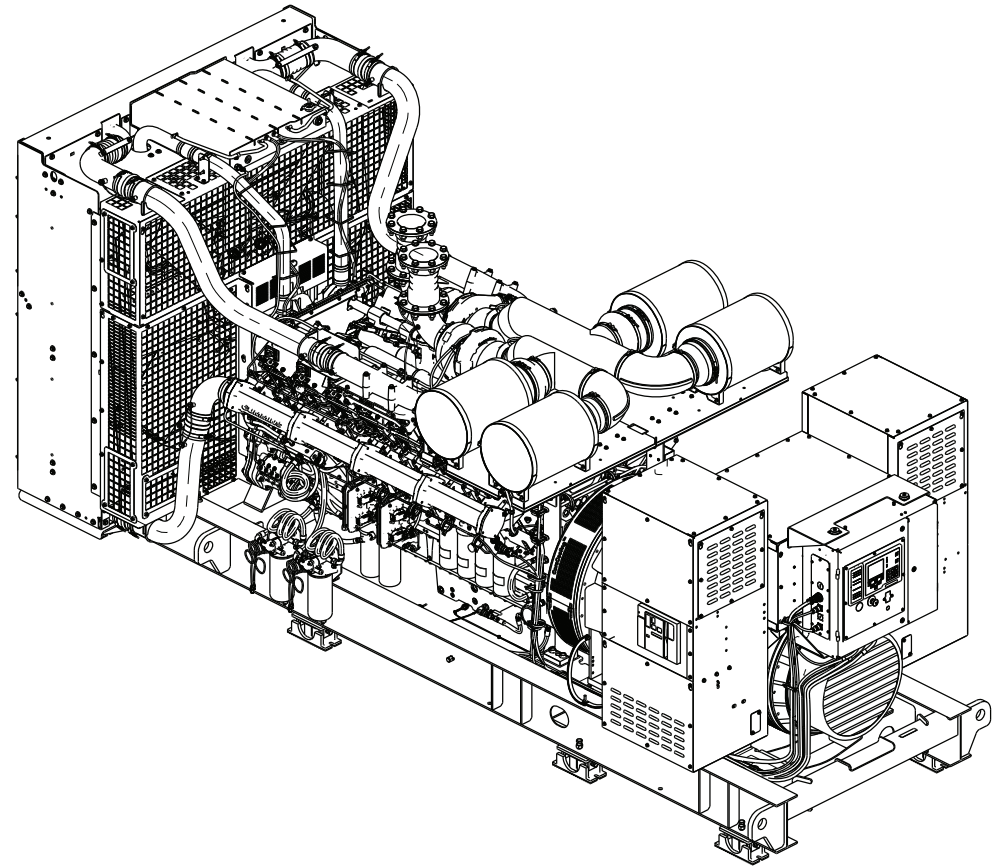

HARD MOUNTED CHASSIS + S7 ALTERNATOR + NORMAL DUTY AIR FILTER

HARD MOUNTED CHASSIS + S9 ALTERNATOR + NORMAL DUTY AIR FILTER

| GENSET MODEL CONFIGURATION TABLE | | | | | |
|----------------------------------|----------|------------------------------------|------------|------------------------|-------------------------------------------|
| GENSET MODEL | ENGINE | INSTALLATION FAN (COOLING SYSTEM) | ALTERNATOR | AIR CLEANER | CB |
| OSK50-G24 | A073W661 | INSTALLATION, FAN (STD FAN) | S7-C | NORMAL DUTY HEAVY DUTY | 2 CB 1 CB ENTRANCE BOX ONLY (NO CB) |
| OSK50-G25 | A073W321 | INSTALLATION, FAN (HIGH SPEED FAN) | | NORMAL DUTY HEAVY DUTY | |
| OSK50-G24 | A073W661 | INSTALLATION, FAN (STD FAN) | S7-D | NORMAL DUTY HEAVY DUTY | 2 CB 1 CB ENTRANCE BOX ONLY (NO CB) |
| OSK50-G25 | A073W321 | INSTALLATION, FAN (HIGH SPEED FAN) | | NORMAL DUTY HEAVY DUTY | |
| OSK50-G24 | A073W661 | INSTALLATION, FAN (STD FAN) | S7-E | NORMAL DUTY HEAVY DUTY | 2 CB 1 CB ENTRANCE BOX ONLY (NO CB) |
| OSK50-G25 | A073W321 | INSTALLATION, FAN (HIGH SPEED FAN) | | NORMAL DUTY HEAVY DUTY | |
| OSK50-G24 | A073W661 | INSTALLATION, FAN (STD FAN) | S7-F | NORMAL DUTY HEAVY DUTY | 2 CB 1 CB ENTRANCE BOX ONLY (NO CB) |
| OSK50-G25 | A073W321 | INSTALLATION, FAN (HIGH SPEED FAN) | | NORMAL DUTY HEAVY DUTY | |
| OSK50-G24 | A073W661 | INSTALLATION, FAN (STD FAN) | S7-G | NORMAL DUTY HEAVY DUTY | 2 CB 1 CB ENTRANCE BOX ONLY (NO CB) |
| OSK50-G25 | A073W321 | INSTALLATION, FAN (HIGH SPEED FAN) | | NORMAL DUTY HEAVY DUTY | |
| C1750D6E & C2000D6E | A073W661 | INSTALLATION, FAN (STD FAN) | S7-H | NORMAL DUTY HEAVY DUTY | 2 CB 1 CB ENTRANCE BOX ONLY (NO CB) |
| OSK50-G25 | A073W321 | INSTALLATION, FAN (HIGH SPEED FAN) | | NORMAL DUTY HEAVY DUTY | |
| OSK50-G24 | A073W661 | INSTALLATION, FAN (STD FAN) | S7-J | NORMAL DUTY HEAVY DUTY | 2 CB 1 CB ENTRANCE BOX ONLY (NO CB) |
| OSK50-G25 | A073W321 | INSTALLATION, FAN (HIGH SPEED FAN) | | NORMAL DUTY HEAVY DUTY | |
| OSK50-G24 | A073W661 | INSTALLATION, FAN (STD FAN) | S9-B | NORMAL DUTY HEAVY DUTY | ENTRANCE BOX ONLY (NO CB) |
| OSK50-G25 | A073W321 | INSTALLATION, FAN (HIGH SPEED FAN) | | NORMAL DUTY HEAVY DUTY | |
| OSK50-G24 | A073W661 | INSTALLATION, FAN (STD FAN) | S9-C | NORMAL DUTY HEAVY DUTY | ENTRANCE BOX ONLY (NO CB) |
| OSK50-G25 | A073W321 | INSTALLATION, FAN (HIGH SPEED FAN) | | NORMAL DUTY HEAVY DUTY | |
| OSK50-G24 | A073W661 | INSTALLATION, FAN (STD FAN) | S9-D | NORMAL DUTY HEAVY DUTY | ENTRANCE BOX ONLY (NO CB) |
| OSK50-G25 | A073W321 | INSTALLATION, FAN (HIGH SPEED FAN) | | NORMAL DUTY HEAVY DUTY | |

| OTHER AVAILABLE OPTIONS | |
|-------------------------|----------------------------------|
| 1 | COOLANT HEATER |
| 2 | OIL DRAIN VALVE |
| 3 | OIL HEATER |
| 4 | ALTERNATOR HEATER |
| 6 | BATTERY HEATER |
| 7 | OIL MAKE UP |
| 8 | OIL SAMPLING VALVE |
| 9 | FUEL IN AND DRAIN HOSES |
| 10 | EXHAUST BELLOWS |
| 11 | MUFFLER |
| 12 | REDUNDANT STARTER/BATTERY SYSTEM |
| 13 | AIR RESTRICTION INDICATORS |
| 14 | SEISMIC-ANTI-VIBRATION ISOLATORS |
| 15 | BATTERY CHARGER |

PART NUMBER: A060C089 PART REVISION: D
 PART NAME: OUTLINE GENSET
 DRAWING CATEGORY: DETAIL
 STATE: RELEASED SHEET: 2 OF 10
 CUMMINS DATA CLASSIFICATION: CUMMINS CONFIDENTIAL
 THIS DOCUMENT (AND THE INFORMATION SHOWN THEREON) IS CONFIDENTIAL AND PROPRIETARY AND SHALL NOT BE DISCLOSED TO OTHERS IN HARD COPY OR ELECTRONIC FORM, REPRODUCED BY ANY MEANS, OR USED FOR ANY PURPOSE, WITHOUT WRITTEN CONSENT OF CUMMINS INC.

| | |
|-----------------------------------------------------------------------------|-------------------------------|
| LAST DATUM LETTER USED: - | LAST REFERENCE LETTER USED: E |
| MODEL/PLATFORM: OSK50 | THIS PART IS SIMILAR TO: - |
| UNLESS OTHERWISE SPECIFIED THE FOLLOWING SHALL APPLY ANG. TOL.: ± 1.0° | |
| SURFACE FINISH PER: - | SURFACE FINISH: - |
| WALL THICKNESS: 1 | DRAFT ANGLES: - |
| DIMENSIONAL TOLERANCES: ± 0.3 | EDGE RADIUS: - |
| HOLE SIZE 0.00-4.99 | HOLE SIZE 5.00-9.99 |
| TOL. ± 0.15/-0.08 | TOL. ± 0.20/-0.10 |
| HOLE SIZE 10.00-17.49 | HOLE SIZE 17.50-24.99 |
| TOL. ± 0.25/-0.13 | TOL. ± 0.30/-0.13 |

Cummins Inc. PTC® Creo® Parametric
 DIMENSIONS ARE IN: MILLIMETERS SIZE: A0 SCALE: 1/16
 DIMENSIONS ARE IN: INCHES CAD SYSTEM
 DIMENSIONING AND TOLERANCING PER: ASME Y14.5-2009 THIRD ANGLE PROJECTION

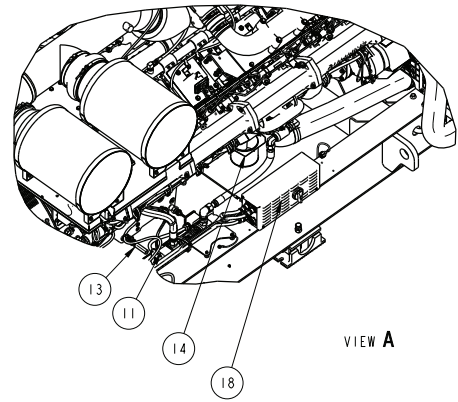

VIEW A

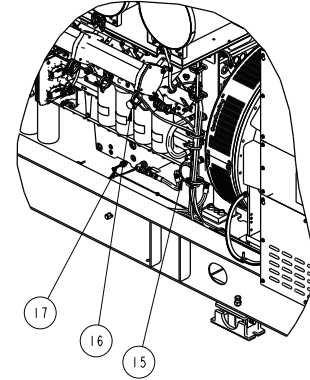

VIEW B

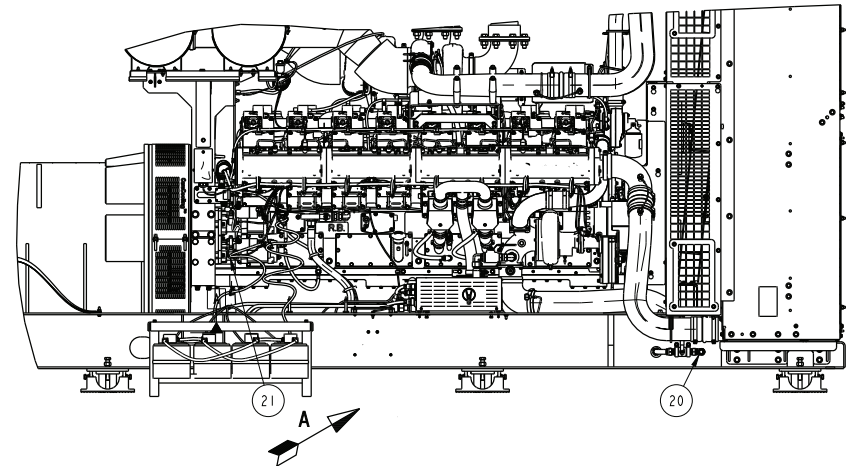
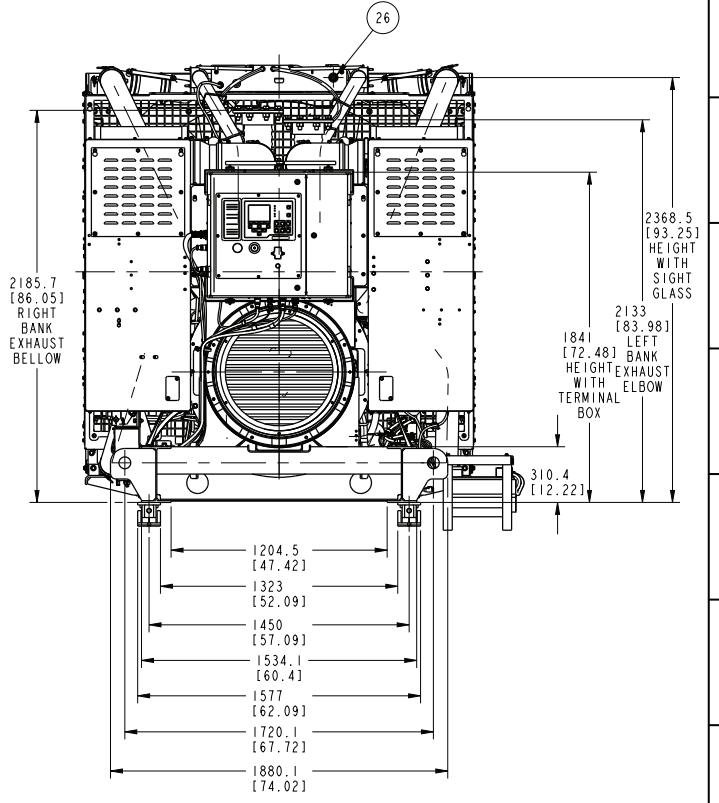
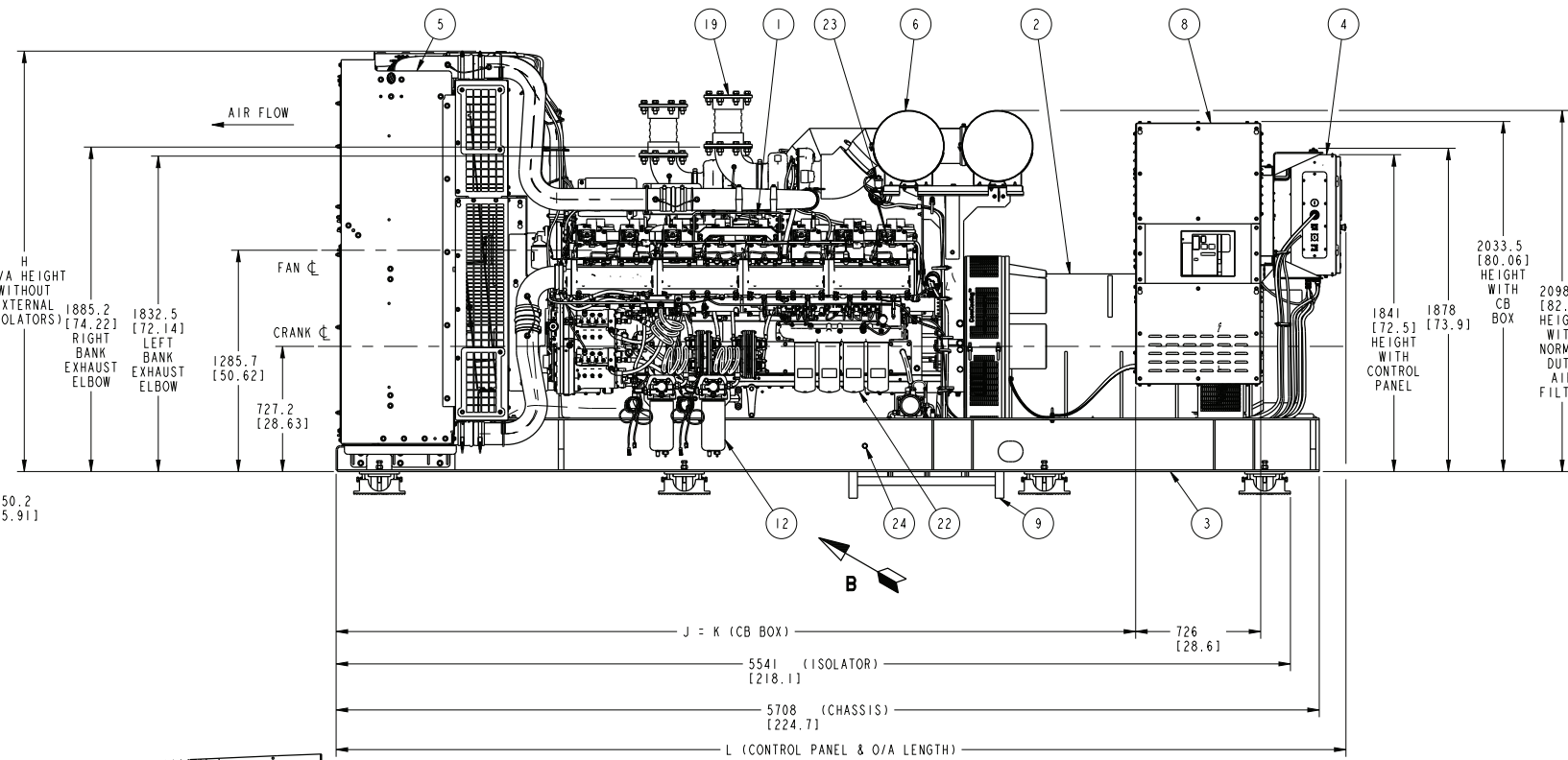
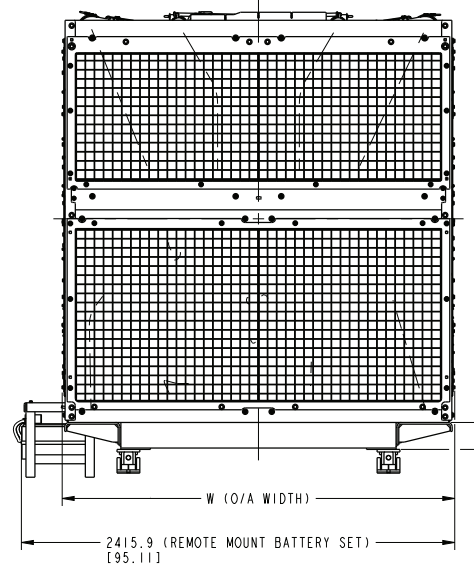
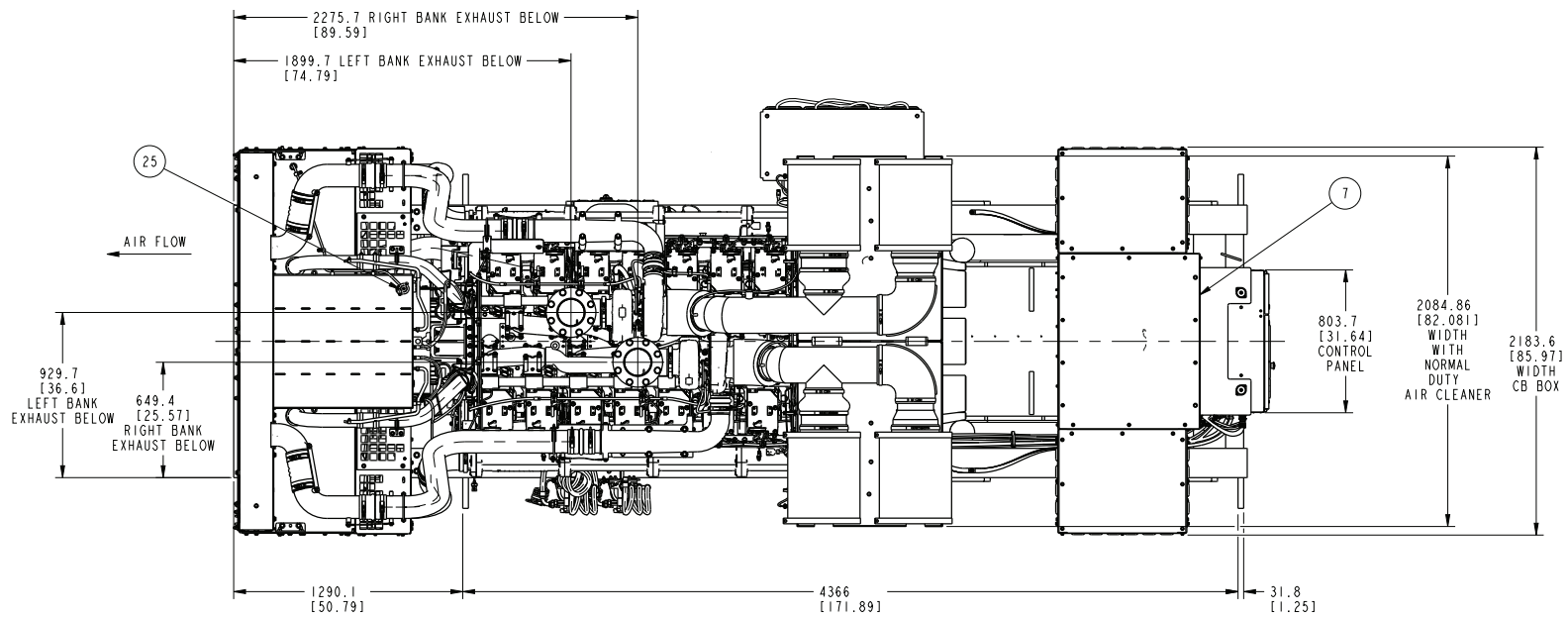

LEFT HAND SIDE GENSET VIEW

| ALTERNATOR | J | K | L (UP TO CONTROL PANEL) |
|------------|------|------|-------------------------|
| S7 C CORE | 4356 | 4356 | 5578 |
| S7 D CORE | 4476 | 4476 | 5698 |
| S7 E CORE | 4476 | 4476 | 5698 |
| S7 F CORE | 4476 | 4476 | 5698 |
| S7 G CORE | 4556 | 4556 | 5778 |
| S7 H CORE | 4677 | 4677 | 5898 |
| S7 J CORE | 4642 | 4642 | 5863 |

| 1 | 20 | COOLANT DRAIN | 1 | 8 | CIRCUIT BREAKER BOX |
|-----|----------|------------------------------------------------------|-----|----------|----------------------|
| 2 | 19 | EXHAUST BELLOWS | 1 | 7 | TERMINAL BOX |
| 1 | 18 | HEATER CONTROL BOX | 4 | 6 | AIR FILTER |
| 1 | 17 | OIL HEATER | 1 | 5 | COOLING SYSTEM |
| 1 | 16 | OIL SAMPLING VALVE | 1 | 4 | CONTROL PANEL |
| 1 | 15 | ENGINE LUBE OIL LEVEL MAINTAINER | 1 | 3 | CHASSIS-HARD MOUNT |
| 1 | 14 | OIL DRIP CAN | 1 | 2 | ALTERNATOR-STJ |
| 1 | 13 | OIL DRAIN VALVE | 1 | 1 | ENGINE OSK50-G24/G25 |
| 2 | 12 | FUEL WATER SEPARATOR | | | |
| 1 | 11 | COOLANT HEATER | | | |
| 4 | 10 | REDUNDANT STARTER BATTERY/TRAY OPTION (REMOTE MOUNT) | | | |
| 4 | 9 | STANDARD STARTER BATTERY/TRAY OPTION (REMOTE MOUNT) | | | |
| 1 | 8 | CIRCUIT BREAKER BOX | | | |
| 1 | 7 | TERMINAL BOX | | | |
| 1 | 6 | AIR FILTER | | | |
| 1 | 5 | COOLING SYSTEM | | | |
| 1 | 4 | CONTROL PANEL | | | |
| 1 | 3 | CHASSIS-HARD MOUNT | | | |
| 1 | 2 | ALTERNATOR-STJ | | | |
| 1 | 1 | ENGINE OSK50-G24/G25 | | | |
| QTY | FIND NO. | DESCRIPTION | QTY | FIND NO. | DESCRIPTION |

| | | |
|---|----|------------------------------------------------------|
| 1 | 20 | COOLANT DRAIN |
| 2 | 19 | EXHAUST BELLOWS |
| 1 | 18 | HEATER CONTROL BOX |
| 1 | 17 | OIL HEATER |
| 1 | 16 | OIL SAMPLING VALVE |
| 1 | 15 | ENGINE LUBE OIL LEVEL MAINTAINER |
| 1 | 14 | OIL DRIP CAN |
| 1 | 13 | OIL DRAIN VALVE |
| 2 | 12 | FUEL WATER SEPARATOR |
| 1 | 11 | COOLANT HEATER |
| 4 | 10 | REDUNDANT STARTER BATTERY/TRAY OPTION (REMOTE MOUNT) |
| 4 | 9 | STANDARD STARTER BATTERY/TRAY OPTION (REMOTE MOUNT) |
| 1 | 8 | CIRCUIT BREAKER BOX |
| 1 | 7 | TERMINAL BOX |
| 1 | 6 | AIR FILTER |
| 1 | 5 | COOLING SYSTEM |
| 1 | 4 | CONTROL PANEL |
| 1 | 3 | CHASSIS-HARD MOUNT |
| 1 | 2 | ALTERNATOR-STJ |
| 1 | 1 | ENGINE OSK50-G24/G25 |

LAST DATUM LETTER USED: - LAST REFERENCE LETTER USED: E
 MODEL/PLATFORM: OSK50 THIS PART IS SIMILAR TO: -
 UNLESS OTHERWISE SPECIFIED THE FOLLOWING SHALL APPLY ANG. TOL.: ± 1.0°
 SURFACE FINISH PER: SURFACE FINISH:
 WALL THICKNESS: 1 DRAFT ANGLES: - EDGE RADIUS: - FILLET RADIUS: -
 DIMENSIONAL TOLERANCES: ± 0.3 ± 0.1 ± 0.5
 HOLE SIZE 0.00-4.99 HOLE SIZE 5.00-9.99 HOLE SIZE 10.00-17.99 HOLE SIZE 17.99-24.99
 TOL. +0.15/-0.08 TOL. +0.20/-0.10 TOL. +0.25/-0.13 TOL. +0.30/-0.13

PART NUMBER: A060C089 PART REVISION: D
 PART NAME: OUTLINE GENSET
 DRAWING CATEGORY: DETAIL
 STATE: RELEASED SHEET: 3 OF 10
 CUMMINS DATA CLASSIFICATION: CUMMINS CONFIDENTIAL
 THIS DOCUMENT (AND THE INFORMATION SHOWN THEREON) IS CONFIDENTIAL AND PROPRIETARY AND SHALL NOT BE DISCLOSED TO OTHERS IN HARD COPY OR ELECTRONIC FORM, REPRODUCED BY ANY MEANS, OR USED FOR ANY PURPOSE, WITHOUT WRITTEN CONSENT OF CUMMINS INC.
 ASME Y14.5-2009 THIRD ANGLE PROJECTION

Cummins Inc.
 DIMENSIONS ARE IN: MILLIMETERS SIZE: A0 SCALE: 1/16
 () ARE IN: INCHES
 DIMENSIONING AND TOLERANCING PER: CAD SYSTEM
 PTC® Creo® Parametric

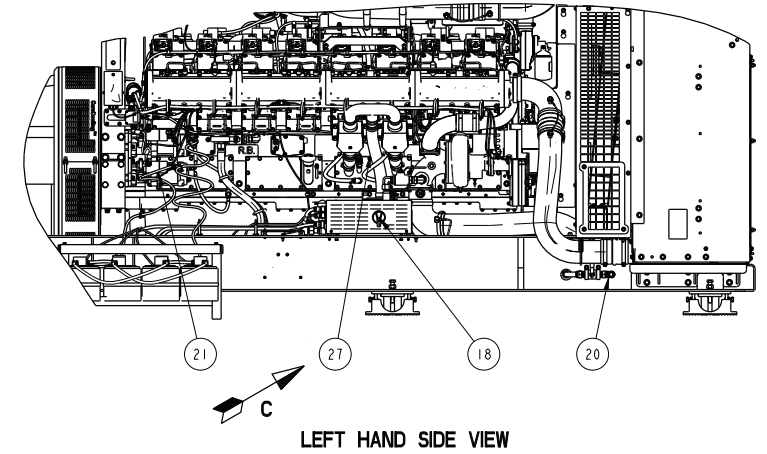
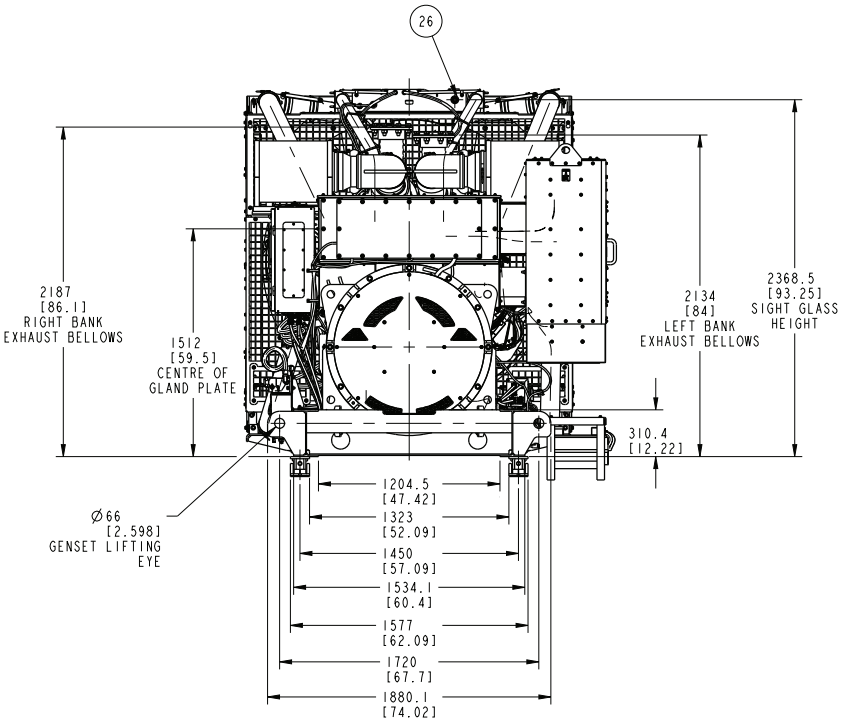
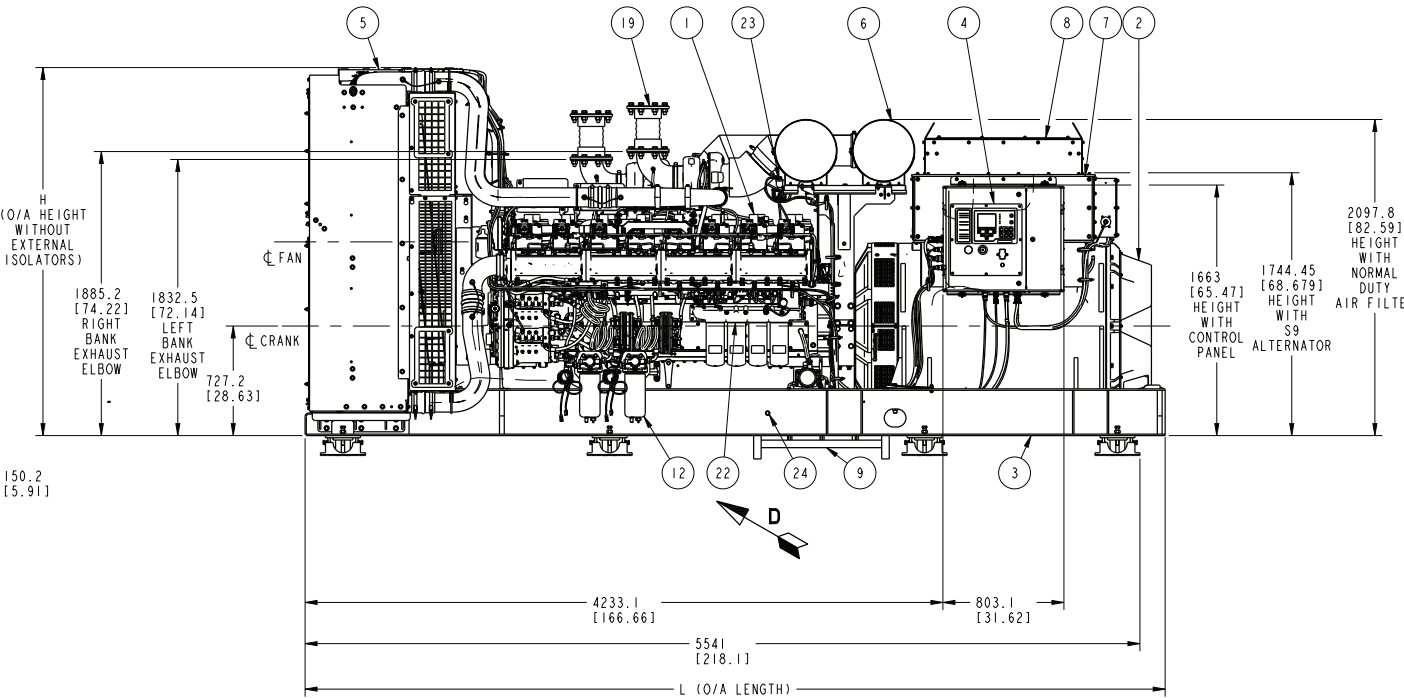
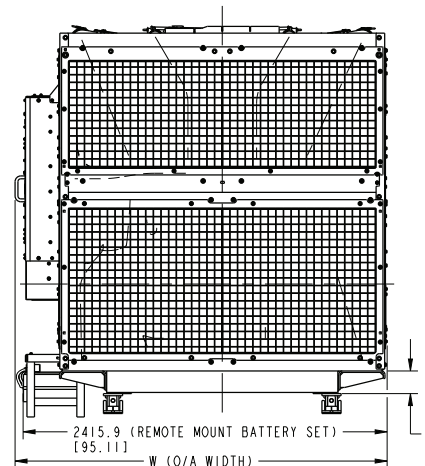
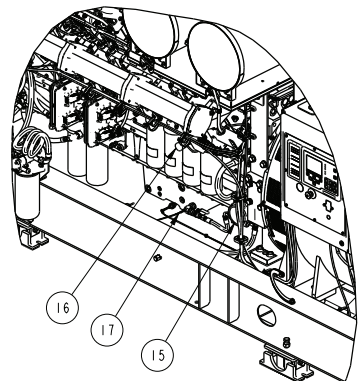
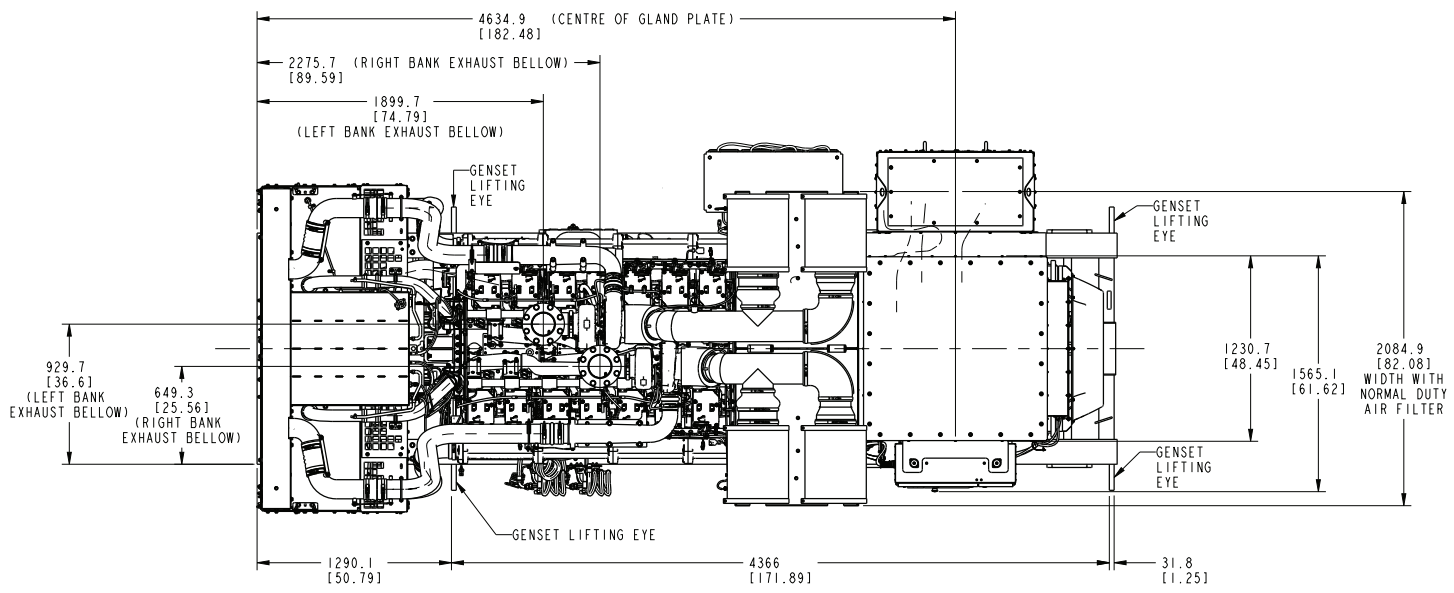
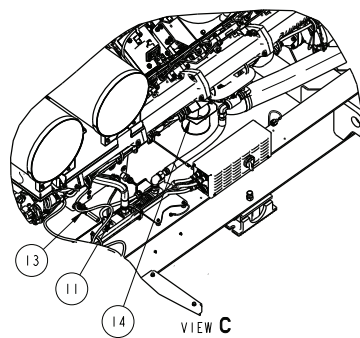

| | | |
|-----|----|------------------------------------------------------|
| 1 | 20 | COOLANT DRAIN |
| 2 | 19 | EXHAUST BELLOWS |
| 1 | 18 | HEATER CONTROL BOX |
| 1 | 17 | OIL HEATER |
| 1 | 16 | OIL SAMPLING VALVE |
| 1 | 15 | ENGINE LUBE OIL LEVEL MAINTAINER |
| 1 | 14 | OIL DRIP CAN |
| 1 | 13 | OIL DRAIN VALVE |
| 2 | 12 | FUEL WATER SEPARATOR |
| 1 | 11 | COOLANT HEATER |
| 4 | 10 | REDUNDANT STARTER BATTERY/TRAY OPTION (REMOTE MOUNT) |
| 4 | 9 | STANDARD STARTER BATTERY/TRAY OPTION (REMOTE MOUNT) |
| 1 | 8 | CIRCUIT BREAKER BOX |
| N/A | 7 | TERMINAL BOX |
| 4 | 6 | AIR FILTER |
| 1 | 5 | COOLING SYSTEM |
| 1 | 4 | CONTROL PANEL |
| 1 | 3 | CHASSIS-HARD MOUNT |
| 4 | 2 | ALTERNATOR-S9D |
| 2 | 21 | STARTER MOTOR |
| 1 | 1 | ENGINE OSK50-G24/G25 |

| | | |
|---|----|---------------------------|
| 1 | 27 | CRANK CASE VENTILATION |
| 1 | 26 | COOLANT LEVEL GAUGE |
| 1 | 25 | RADIATOR FILL POINT |
| 1 | 24 | LUBE OIL FILL POINT |
| 1 | 23 | AIR RESTRICTION INDICATOR |
| 4 | 22 | LUBE OIL FILTER |
| 2 | 21 | STARTER MOTOR |

PART NUMBER: A060C089 PART REVISION: D
 PART NAME: OUTLINE: GENSET
 DRAWING CATEGORY: DETAIL
 STATE: RELEASED SHEET: 4 OF 10
 CUMMINS DATA CLASSIFICATION: CUMMINS CONFIDENTIAL
 THIS DOCUMENT (AND THE INFORMATION SHOWN THEREON) IS CONFIDENTIAL AND PROPRIETARY AND SHALL NOT BE DISCLOSED TO OTHERS IN HARD COPY OR ELECTRONIC FORM, REPRODUCED BY ANY MEANS, OR USED FOR ANY PURPOSE, WITHOUT WRITTEN CONSENT OF CUMMINS INC.

| | |
|-------------------------------------------------------------------------|-------------------------------|
| LAST DATUM LETTER USED: - | LAST REFERENCE LETTER USED: E |
| MODEL/PLATFORM: OSK50 | THIS PART IS SIMILAR TO: - |
| UNLESS OTHERWISE SPECIFIED THE FOLLOWING SHALL APPLY: ANG. TOL.: ± 1.0° | |
| SURFACE FINISH PER: - | SURFACE FINISH: - |
| WALL THICKNESS: - | DRAFT ANGLES: - |
| DIMENSIONAL TOLERANCES: ± 0.3 | EDGE RADIUS: - |
| HOLE SIZE 0.00-4.99 | HOLE SIZE 5.00-9.99 |
| TOL. +0.15/-0.08 | TOL. +0.20/-0.10 |
| HOLE SIZE 10.00-17.49 | HOLE SIZE 17.50-24.99 |
| TOL. +0.25/-0.13 | TOL. +0.30/-0.13 |

Cummins Inc.
 DIMENSIONS ARE IN: MILLIMETERS
 () ARE IN: INCHES
 SIZE: A0 SCALE: 1/16
 DIMENSIONING AND TOLERANCING PER: ASME Y14.5-2009
 THIRD ANGLE PROJECTION
 CAD SYSTEM: PTC® Creo® Parametric

FUEL SUPPLY, LIFTING LUG, OIL MAINTAINER AND S7, S9 NON-SEISMIC ISOLATOR INSTALLATION DETAIL

NOTES:
 △ REFER TO GENSET INSTALLATION DRAWING A065D207-INSTALLATION, GENSET SEISMIC ISOLATOR AND A065D206-INSTALLATION, GENSET NON SEISMIC INSTALLATION DETAILS

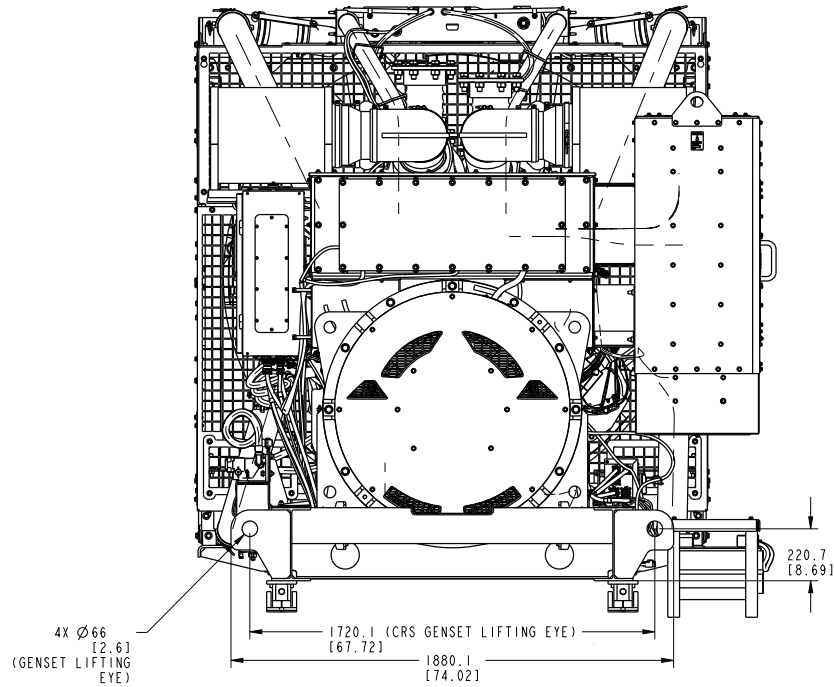
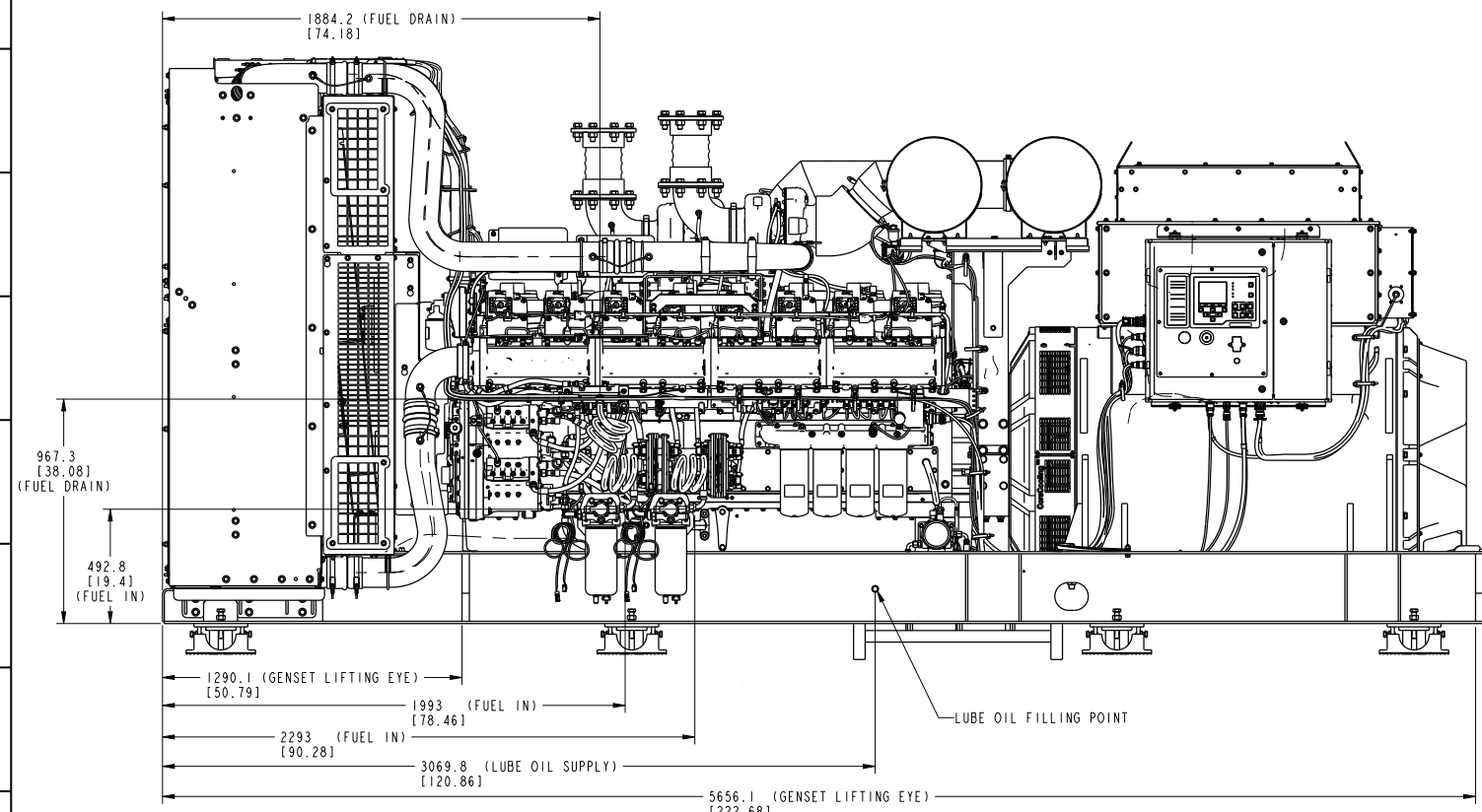

SCALE 3/32

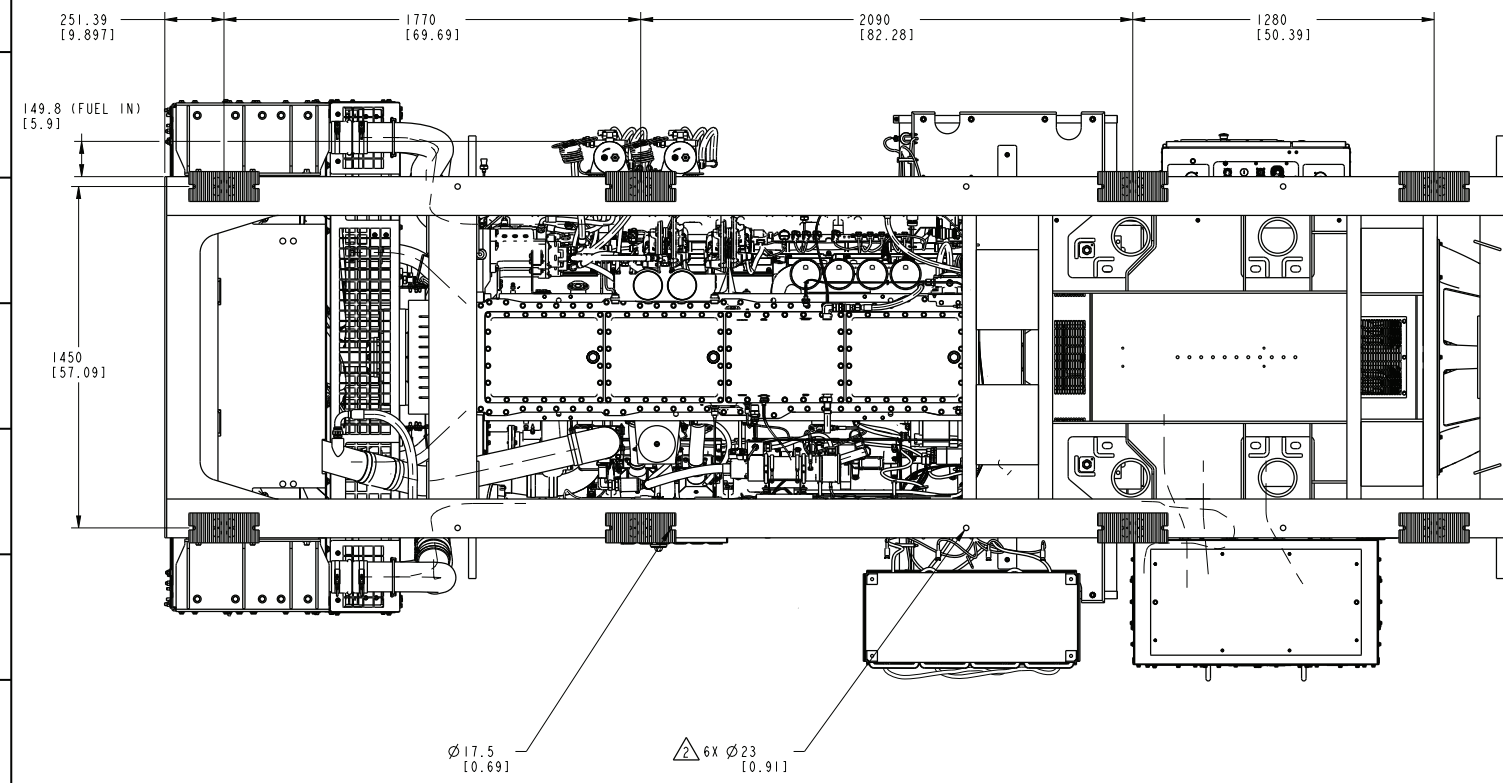

| FUEL SYSTEM CONNECTOR DETAILS | | | |
|-------------------------------|-----------------------------------|------------------------------------|--------------------|
| DESCRIPTION | ON FILTER | HOSE | |
| | | FILTER SIDE | CUSTOMER SIDE |
| FUEL IN | 1-1/16-12 UN JIC SWIVEL 37° FLARE | 1-1/16-12 90° ELBOW JIC SWIVEL 37° | 3/4 NPTF MALE PIPE |

| FUEL SYSTEM CONNECTOR DETAILS | | | |
|-------------------------------|---------------------------|------------------------------------------------|--------------------|
| DESCRIPTION | ON ENGINE | HOSE | |
| | | ENGINE SIDE | CUSTOMER SIDE |
| FUEL DRAIN | 1-1/16-12 UN-2A 37° FLARE | 1-1/16-12 STRAIGHT JIC SWIVEL FEMALE 37° FLARE | 3/4 NPTF MALE PIPE |

| OIL MAINTAINER SYSTEM CONNECTOR DETAILS | |
|-----------------------------------------|----------------------------------|
| LUBE OIL SUPPLY | 3/4" (THREAD) JIC 37° (SAE J514) |

Ø17.5 [0.69] △ 6X Ø23 [0.91]

| | |
|--------------------------------------------------------------------------------------------------------------------------------------------------------------------------------------------------------------------------------------------------|------------------|
| PART NUMBER: A060C089 | PART REVISION: D |
| PART NAME: OUTLINE GENSET | |
| DRAWING CATEGORY: DETAIL | |
| STATE: RELEASED | SHEET: 5 OF 10 |
| CUMMINS DATA CLASSIFICATION: CUMMINS CONFIDENTIAL | |
| THIS DOCUMENT (AND THE INFORMATION SHOWN THEREON) IS CONFIDENTIAL AND PROPRIETARY AND SHALL NOT BE DISCLOSED TO OTHERS IN HARD COPY OR ELECTRONIC FORM, REPRODUCED BY ANY MEANS, OR USED FOR ANY PURPOSE WITHOUT WRITTEN CONSENT OF CUMMINS INC. | |
| | |
| DIMENSIONS ARE IN: MILLIMETERS () ARE IN: INCHES | |
| DIMENSIONING AND TOLERANCING PER: ASME Y14.5-2009 | |
| THIRD ANGLE PROJECTION | |
| CAD SYSTEM: PTC® Creo® Parametric | |

**PARALLEL LIFT:
S9 ALTERNATOR CONFIGURATION**
IDEAL LIFTING FRAME AND STROPS

FOR C OF G VALUES REFER TO
SHEET 8 : FOR S9 (ALL CORE) ALTERNATOR
SHEET 8 : FOR S7(ALL CORE) ALTERNATOR

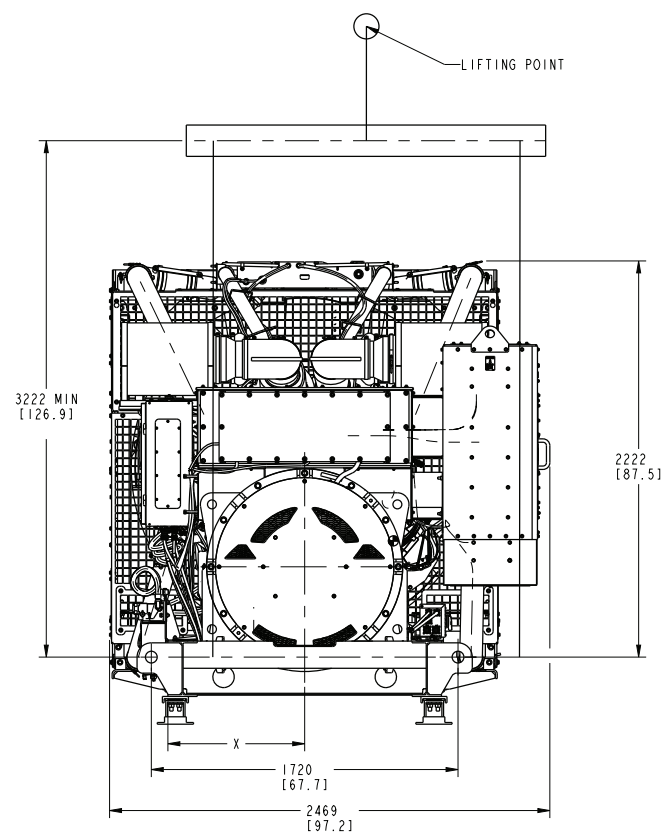
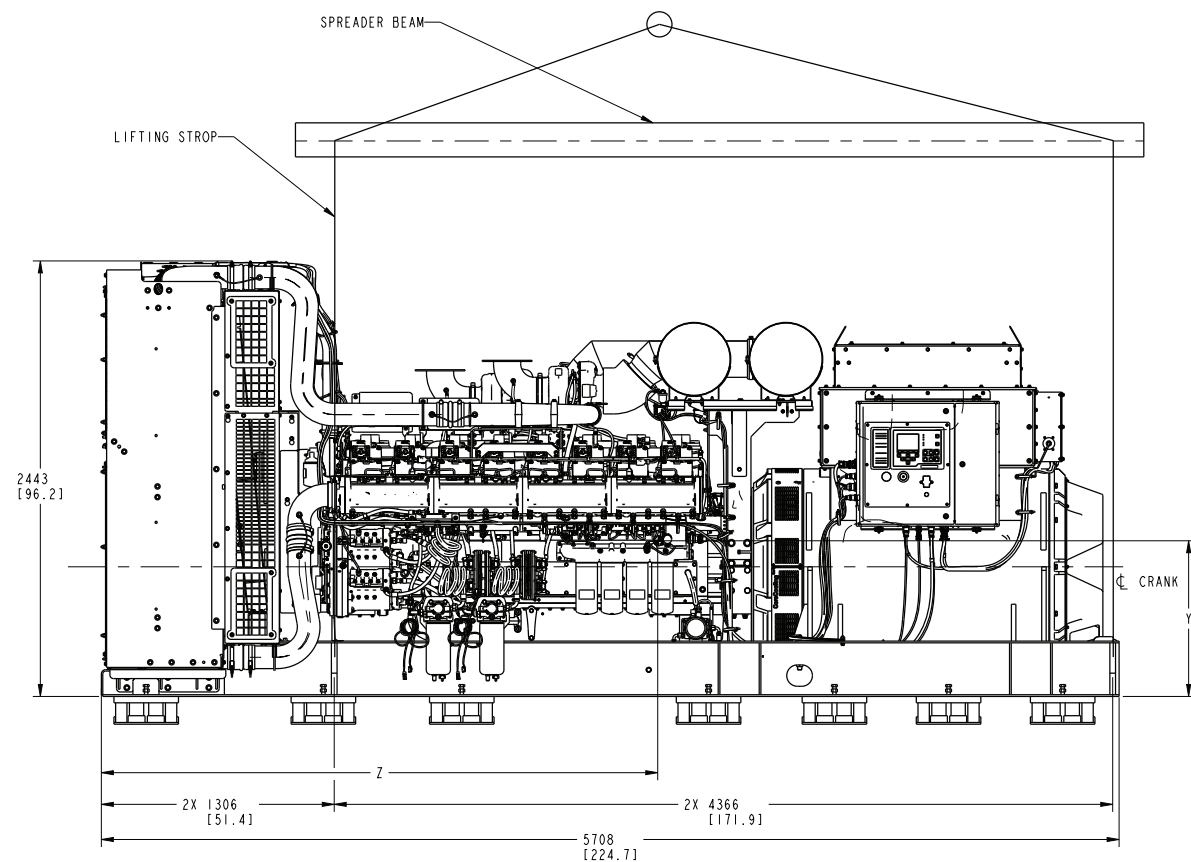
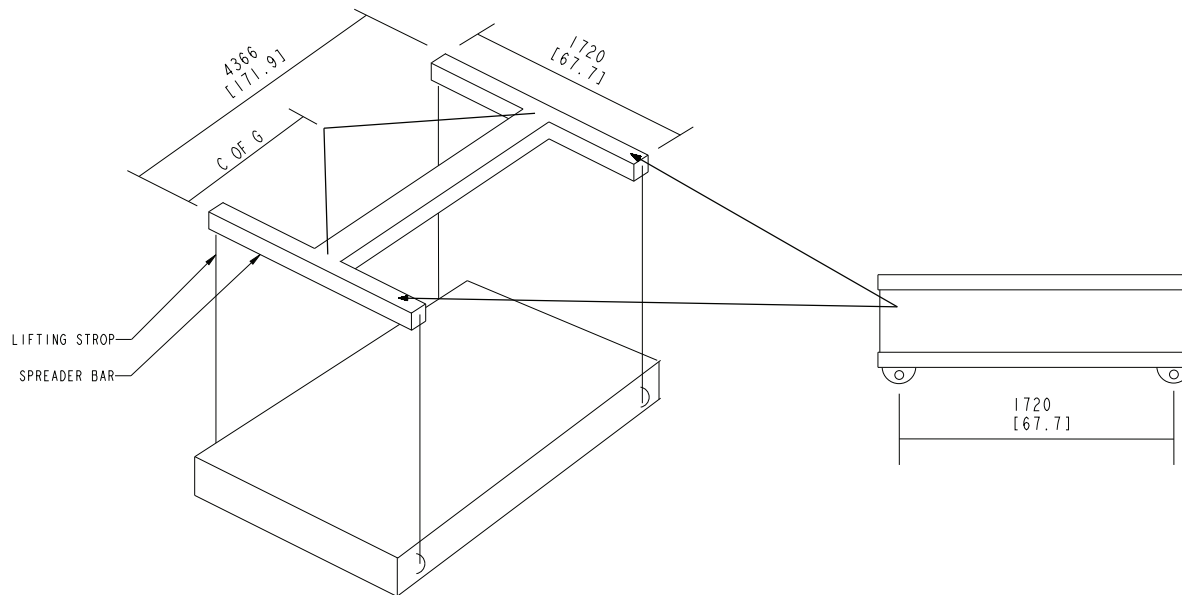

| | |
|--------------------------------------------------------------------------------------------------------------------------------------------------------------------------------------------------------------------------------------------------|------------------|
| PART NUMBER: A060C089 | PART REVISION: D |
| PART NAME: OUTLINE GENSET | |
| DRAWING CATEGORY: DETAIL | |
| STATE: RELEASED | SHEET: 6 OF 10 |
| CUMMINS DATA CLASSIFICATION: CUMMINS CONFIDENTIAL | |
| THIS DOCUMENT (AND THE INFORMATION SHOWN THEREON) IS CONFIDENTIAL AND PROPRIETARY AND SHALL NOT BE DISCLOSED TO OTHERS IN HARD COPY OR ELECTRONIC FORM, REPRODUCED BY ANY MEANS, OR USED FOR ANY PURPOSE WITHOUT WRITTEN CONSENT OF CUMMINS INC. | |

| | |
|------------------------------------------------------|-------------------------------|
| LAST DATUM LETTER USED: - | LAST REFERENCE LETTER USED: E |
| MODEL/PLATFORM: OSK50 | THIS PART IS SIMILAR TO: - |
| UNLESS OTHERWISE SPECIFIED THE FOLLOWING SHALL APPLY | |
| SURFACE FINISH PER: - | SURFACE FINISH: - |
| WALL THICKNESS: - | DRAFT ANGLES: - |
| DIMENSIONAL TOLERANCES: - | EDGE RADIUS: - |
| HOLE SIZE 0.00-4.99 | HOLE SIZE 5.00-9.99 |
| TOL. +0.15/-0.08 | TOL. +0.20/-0.10 |
| HOLE SIZE 10.00-17.49 | HOLE SIZE 17.50-24.99 |
| TOL. +0.25/-0.13 | TOL. +0.30/-0.13 |

Cummins Inc.

DIMENSIONS ARE IN: MILLIMETERS
[] ARE IN: INCHES

SIZE: A0 SCALE: 1/16

ASME Y14.5-2009

THIRD ANGLE PROJECTION

CAD SYSTEM
PTC® Creo® Parametric

P PARALLEL LIFT: S7 ALTERNATOR CONFIGURATION WITH CIRCUIT BREAKER BOX P

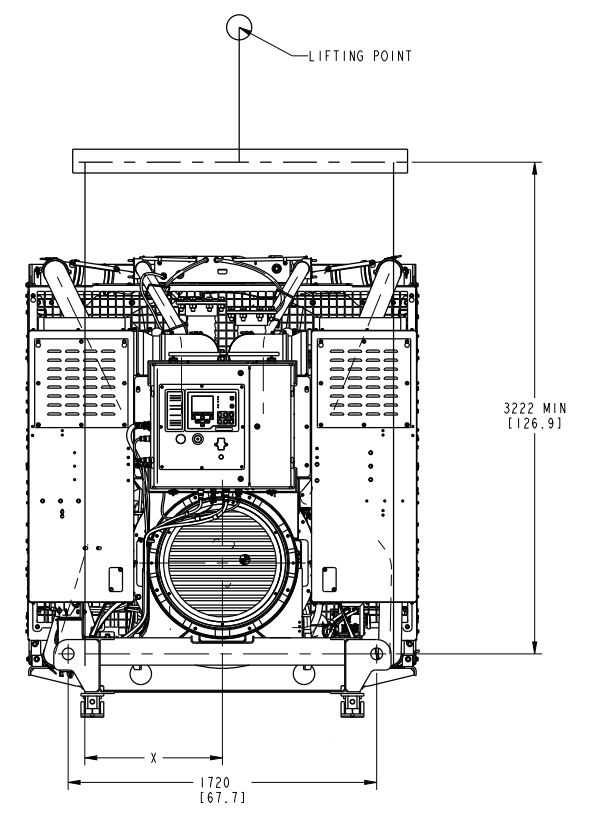
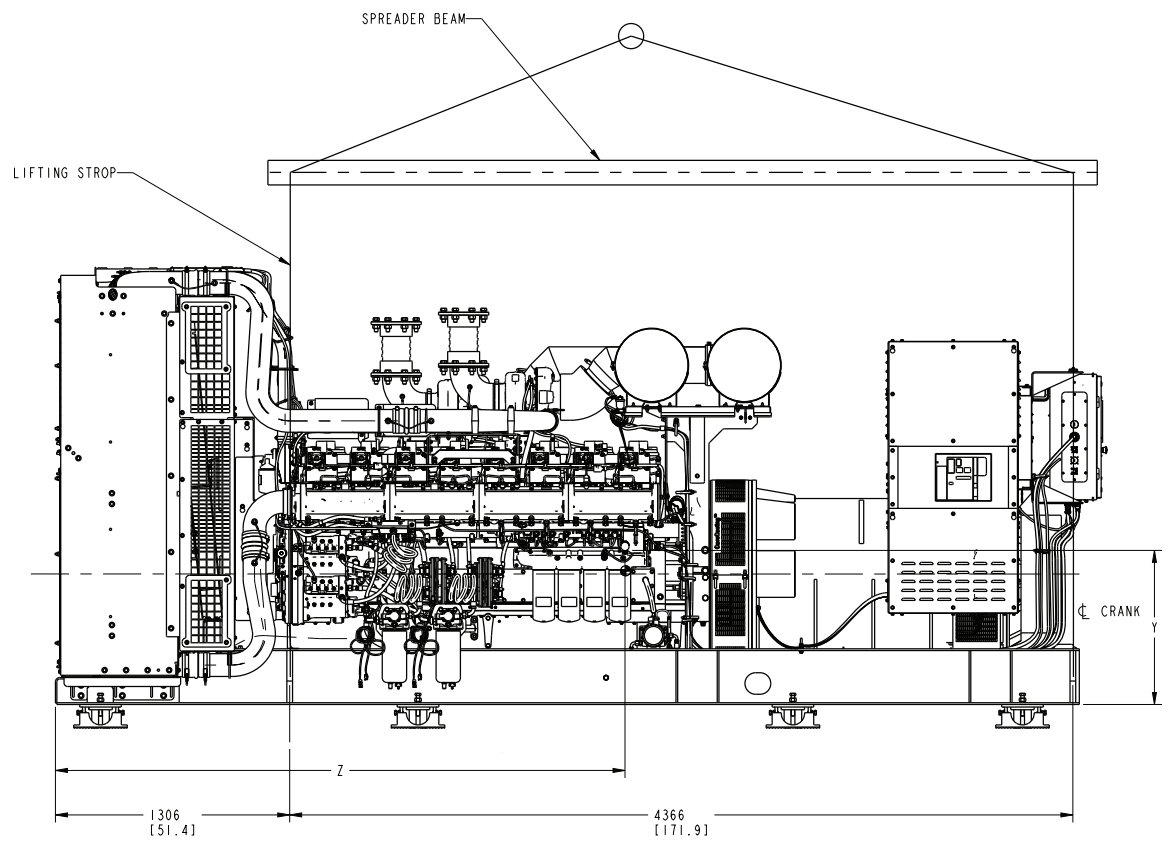

H SINGLE POINT LIFT: S7 ALTERNATOR CONFIGURATION WITHOUT CIRCUIT BREAKER BOX

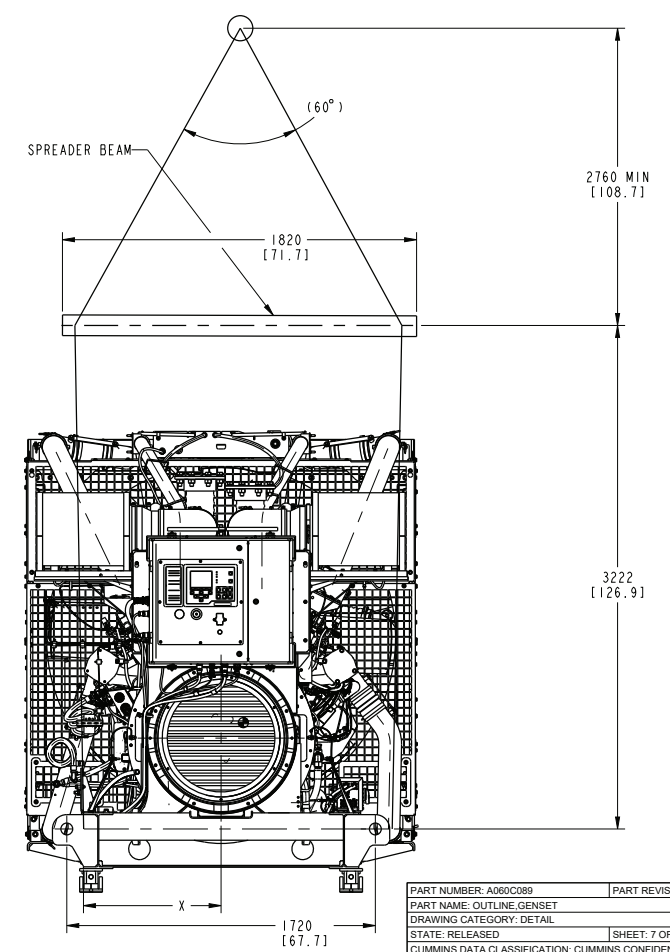
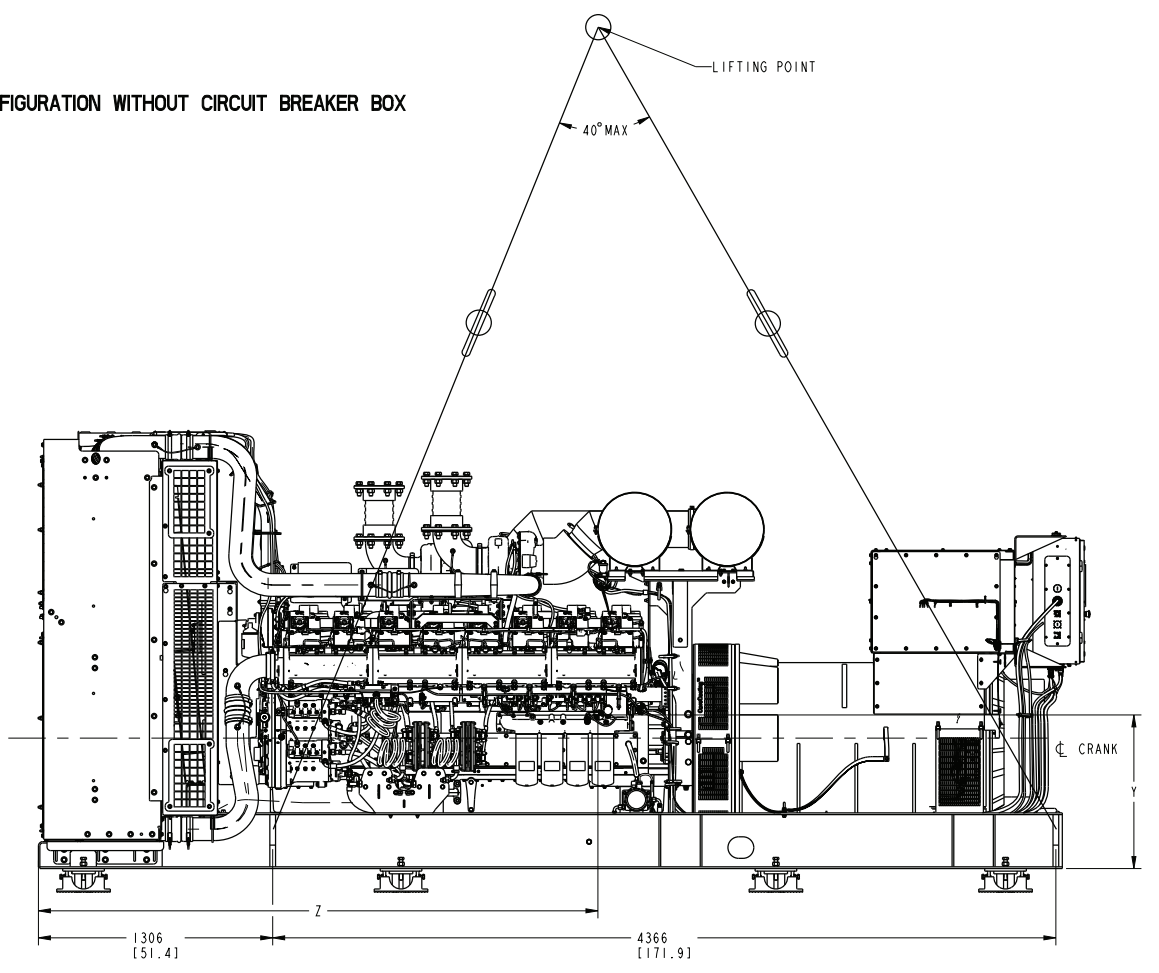

PART NUMBER: A060C089 PART REVISION: D
 PART NAME: OUTLINE GENSET
 DRAWING CATEGORY: DETAIL
 STATE: RELEASED SHEET: 7 OF 10
 CUMMINS DATA CLASSIFICATION: CUMMINS CONFIDENTIAL
 THIS DOCUMENT (AND THE INFORMATION SHOWN THEREON) IS CONFIDENTIAL AND PROPRIETARY AND SHALL NOT BE DISCLOSED TO OTHERS IN HARD COPY OR ELECTRONIC FORM. REPRODUCED BY ANY MEANS OR USED FOR ANY PURPOSE WITHOUT WRITTEN CONSENT OF CUMMINS INC.

| | | | |
|------------------------------------------------------|----------------------|---------------------------------------------------|-----------------------|
| LAST DATUM LETTER USED: - | | LAST REFERENCE LETTER USED: E | |
| MODEL/PLATFORM: OSK50 | | THIS PART IS SIMILAR TO: - | |
| UNLESS OTHERWISE SPECIFIED THE FOLLOWING SHALL APPLY | | | |
| SURFACE FINISH PER: - | | SURFACE FINISH: - | |
| WALL THICKNESS: - | | EDGE RADIUS: - | |
| DRAFT ANGLES: - | | FILLET RADIUS: - | |
| DIMENSIONAL TOLERANCES: - | | TYPICAL: ± 0.5 | |
| HOLE SIZE 0.00-4.99 | HOLE SIZE 5.00-9.99 | HOLE SIZE 10.00-17.49 | HOLE SIZE 17.50-24.99 |
| TOL. ± 0.15 / ± 0.08 | TOL. ± 0.20 / ± 0.10 | TOL. ± 0.25 / ± 0.13 | TOL. ± 0.30 / ± 0.13 |
| DIMENSIONS ARE IN: MILLIMETERS | | SIZE: A0 SCALE: 1/16 | |
| [] ARE IN: INCHES | | DIMENSIONING AND TOLERANCING PER: ASME Y14.5-2009 | |
| CUMMINS INC. | | CAD SYSTEM: PTC® Creo® Parametric | |

P
O
N
M
L
K
J
I
H
G
F
E
D
C
B
A

P
O
N
M
L
K
J
I
H
G
F
E
D
C
B
A

REFER SHEET 3 FOR DRAWING VIEW AND SHEET 7 FOR COFG

| ENGINE | ALTERNATOR | AIR CLEANER | CB OPTION | GENSET WET WEIGHT(KG) | GENSET WET WEIGHT(LBS) | GENSET DRY WEIGHT(KG) | GENSET DRY WEIGHT(LBS) | OVERALL DIMENSIONS MM (INCH) | | | COFG MM (INCH) | | | |
|---------------|----------------------------|----------------------------|--------------------------------------|--------------------------------------|------------------------|-----------------------|------------------------|------------------------------|--------------------------------------|-------------------------------------|----------------|------------|--------------|--------------|
| | | | | | | | | LENGTH | WIDTH (WITHOUT REMOTE MOUNT BATTERY) | HEIGHT (WITHOUT EXTERNAL ISOLATORS) | X | Y | Z | |
| OSK50-G24/G25 | S7-C | NORMAL DUTY/ HEAVY DUTY | 2 CB | 12070 | 26609 | 11693 | 25778 | 5708 (224.7) | 2187 (86.1) | 2443 (96.2) | 760 (29.9) | 897 (35.3) | 2865 (112.8) | |
| | | | LHS CB (VIEW FROM NDE OF ALTERNATOR) | 11779 | 25972 | 11111 | 24499 | | | | 779 (30.6) | 887 (34.9) | 2817 (110.9) | |
| | | | RHS CB (VIEW FROM NDE OF ALTERNATOR) | 11889 | 26212 | 11512 | 25383 | | | | 748 (29.4) | 891 (35) | 2835 (111.6) | |
| | | | NO CB | 11598 | 25573 | 11221 | 24742 | | | | 767 (30.2) | 881 (34.7) | 2786 (109.7) | |
| | S7-D | NORMAL DUTY/ HEAVY DUTY | NORMAL DUTY/ HEAVY DUTY | 2 CB | 12226 | 26953 | 11849 | 26122 | 5708 (224.7) | 2187 (86.1) | 2443 (96.2) | 760 (29.9) | 895 (35.2) | 2900 (114.2) |
| | | | | LHS CB (VIEW FROM NDE OF ALTERNATOR) | 11935 | 26316 | 11558 | 25485 | | | | 779 (30.7) | 885 (34.8) | 2850 (112.2) |
| | | | | RHS CB (VIEW FROM NDE OF ALTERNATOR) | 12045 | 26559 | 11668 | 25727 | | | | 748 (29.4) | 889 (35) | 2869 (112.9) |
| | | | | NO CB | 11754 | 25917 | 11377 | 25086 | | | | 767 | 878 | 2818 |
| | S7-E | NORMAL DUTY/ HEAVY DUTY | NORMAL DUTY/ HEAVY DUTY | 2 CB | 12510 | 27579 | 12133 | 26748 | 5708 (224.7) | 2187 (86.1) | 2443 (96.2) | 760 (29.9) | 891 (35) | 2944 (115.9) |
| | | | | LHS CB (VIEW FROM NDE OF ALTERNATOR) | 12219 | 26942 | 11842 | 26111 | | | | 779 (30.7) | 881 (34.7) | 2897 (114) |
| | | | | RHS CB (VIEW FROM NDE OF ALTERNATOR) | 12329 | 27185 | 11952 | 26354 | | | | 749 (29.5) | 885 (34.9) | 2915 (114.7) |
| | | | | NO CB | 12038 | 26543 | 11661 | 25712 | | | | 767 (30.2) | 875 (34.4) | 2867 (112.9) |
| S7-F | NORMAL DUTY/ HEAVY DUTY | NORMAL DUTY/ HEAVY DUTY | 2 CB | 12510 | 27579 | 12133 | 26748 | 5708 (224.7) | 2187 (86.1) | 2443 (96.2) | 760 (29.9) | 891 (35) | 2944 (115.9) | |
| | | | LHS CB (VIEW FROM NDE OF ALTERNATOR) | 12219 | 26942 | 11842 | 26111 | | | | 779 (30.7) | 881 (34.7) | 2897 (114) | |
| | | | RHS CB (VIEW FROM NDE OF ALTERNATOR) | 12329 | 27185 | 11952 | 26354 | | | | 749 (29.5) | 885 (34.9) | 2915 (114.7) | |
| | | | NO CB | 12038 | 26543 | 11661 | 25712 | | | | 767 (30.2) | 875 (34.4) | 2867 (112.9) | |
| S7-G | NORMAL DUTY/ HEAVY DUTY | NORMAL DUTY/ HEAVY DUTY | 2 CB | 12817 | 28256 | 12440 | 27425 | 5778 (227.4) | 2187 (86.1) | 2443 (96.2) | 760 (29.9) | 886 (34.9) | 2995 (117.9) | |
| | | | LHS CB (VIEW FROM NDE OF ALTERNATOR) | 12526 | 27619 | 12149 | 26788 | | | | 778 (30.6) | 876 (34.5) | 2948 (116) | |
| | | | RHS CB (VIEW FROM NDE OF ALTERNATOR) | 12636 | 27862 | 12259 | 27031 | | | | 749 (29.5) | 881 (34.7) | 2966 (116.8) | |
| | | | NO CB | 12345 | 27220 | 11968 | 26389 | | | | 767 (30.2) | 870 (34.3) | 2918 (114.9) | |
| S7-H | NORMAL DUTY/ HEAVY DUTY | NORMAL DUTY/ HEAVY DUTY | 2 CB | 13261 | 29235 | 12884 | 28404 | 5898 (232.2) | 2187 (86.1) | 2443 (96.2) | 761 (29.9) | 881 (34.7) | 3070 (120.9) | |
| | | | LHS CB (VIEW FROM NDE OF ALTERNATOR) | 12970 | 28598 | 12593 | 27767 | | | | 778 (30.6) | 871 (34.3) | 3024 (119) | |
| | | | RHS CB (VIEW FROM NDE OF ALTERNATOR) | 13080 | 28841 | 12703 | 28010 | | | | 750 (29.5) | 875 (34.4) | 3042 (119.7) | |
| | | | NO CB | 12789 | 28199 | 12412 | 27368 | | | | 767 (30.2) | 865 (34) | 2995 (117.9) | |
| S7-J | NORMAL DUTY/ HEAVY DUTY | NORMAL DUTY/ HEAVY DUTY | 2 CB | 13662 | 30119 | 13285 | 29288 | 5863 (230.8) | 2187 (86.1) | 2443 (96.2) | 761 (30) | 877 (34.5) | 3100 (122) | |
| | | | LHS CB (VIEW FROM NDE OF ALTERNATOR) | 13371 | 29483 | 12994 | 28651 | | | | 778 (30.6) | 868 (34.2) | 3058 (120.4) | |
| | | | RHS CB (VIEW FROM NDE OF ALTERNATOR) | 13481 | 29725 | 13104 | 28894 | | | | 750 (29.5) | 872 (34.3) | 3074 (121) | |
| | | | NO CB | 13190 | 29083 | 12813 | 28252 | | | | 767 (30.2) | 862 (33.9) | 3030 (119.3) | |

REFER SHEET 4 FOR DRAWING VIEW AND SHEET 6 FOR COFG

| ENGINE | ALTERNATOR | AIR CLEANER | CB OPTION | GENSET WET WEIGHT(KG) | GENSET WET WEIGHT(LBS) | GENSET DRY WEIGHT(KG) | GENSET DRY WEIGHT(LBS) | OVERALL DIMENSIONS MM (INCH) | | | COFG MM (INCH) | | |
|---------------|------------|----------------------------|-----------------|-----------------------|------------------------|-----------------------|------------------------|------------------------------|--------------------------------------|-------------------------------------|----------------|------------|--------------|
| | | | | | | | | LENGTH | WIDTH (WITHOUT REMOTE MOUNT BATTERY) | HEIGHT (WITHOUT EXTERNAL ISOLATORS) | X | Y | Z |
| OSK50-G24/G25 | S9-B | NORMAL DUTY/ HEAVY DUTY | NO CB | 13717 | 30245 | 13340 | 29414 | 5708 (224.7) | 2189 (86.2) | 2443 (96.1) | 764 (30) | 866 (34) | 3098 (121.9) |
| | | | NO ENTRANCE BOX | 14013 | 30898 | 13636 | 30067 | 5708 (224.7) | 2470 (97.2) | 2443 (96.1) | 785 (30.9) | 873 (34.4) | 3131 (123.2) |
| | S9-C | NORMAL DUTY/ HEAVY DUTY | NO CB | 13917 | 30686 | 13540 | 29855 | 5708 (224.7) | 2189 (86.2) | 2443 (96.1) | 764 (30) | 864 (34) | 3124 (123) |
| | | | NO ENTRANCE BOX | 14213 | 31339 | 13836 | 30508 | 5708 (224.7) | 2470 (97.2) | 2443 (96.1) | 785 (30.9) | 871 (34.3) | 3156 (124.2) |
| | S9-D | NORMAL DUTY/ HEAVY DUTY | NO CB | 14217 | 31348 | 13840 | 30517 | 5708 (224.7) | 2189 (86.2) | 2443 (96.1) | 764 (30) | 862 (34) | 3161 (124.5) |
| | | | NO ENTRANCE BOX | 14513 | 32001 | 14136 | 31169 | 5708 (224.7) | 2470 (97.2) | 2443 (96.1) | 785 (30.9) | 868 (34.2) | 3192 (125.7) |

| | | | |
|--------------------------------------------------------------------------------------------------------------------------------------------------------------------------------------------------------------------------------------------------|--|-----------------------------------|--|
| LAST DATUM LETTER USED: - | | LAST REFERENCE LETTER USED: E | |
| MODEL/PLATFORM: OSK50 | | THIS PART IS SIMILAR TO: - | |
| UNLESS OTHERWISE SPECIFIED THE FOLLOWING SHALL APPLY | | | |
| SURFACE FINISH PER: - | | SURFACE FINISH: - | |
| WALL THICKNESS: - | | EDGE RADIUS: - | |
| DIMENSIONAL TOLERANCES: - | | FILLET RADIUS: - | |
| HOLE SIZE 0.00-4.99 | | HOLE SIZE 5.00-9.99 | |
| TOL. +0.15/-0.08 | | TOL. +0.20/-0.10 | |
| HOLE SIZE 10.00-17.49 | | HOLE SIZE 17.50-24.99 | |
| TOL. +0.25/-0.13 | | TOL. +0.30/-0.13 | |
| PART NUMBER: A060C089 | | PART REVISION: D | |
| PART NAME: OUTLINE GENSET | | | |
| DRAWING CATEGORY: DETAIL | | | |
| STATE: RELEASED | | SHEET: 8 OF 10 | |
| CUMMINS DATA CLASSIFICATION: CUMMINS CONFIDENTIAL | | | |
| THIS DOCUMENT (AND THE INFORMATION SHOWN THEREON) IS CONFIDENTIAL AND PROPRIETARY AND SHALL NOT BE DISCLOSED TO OTHERS IN HARD COPY OR ELECTRONIC FORM, REPRODUCED BY ANY MEANS, OR USED FOR ANY PURPOSE WITHOUT WRITTEN CONSENT OF CUMMINS INC. | | | |
| DIMENSIONS ARE IN: MILLIMETERS | | SIZE: A0 | |
| [] ARE IN: INCHES | | SCALE: 1/16 | |
| DIMENSIONING AND TOLERANCING PER: ASME Y14.5-2009 | | THIRD ANGLE PROJECTION | |
| CUMMINS Inc. | | CAD SYSTEM: PTC® Creo® Parametric | |

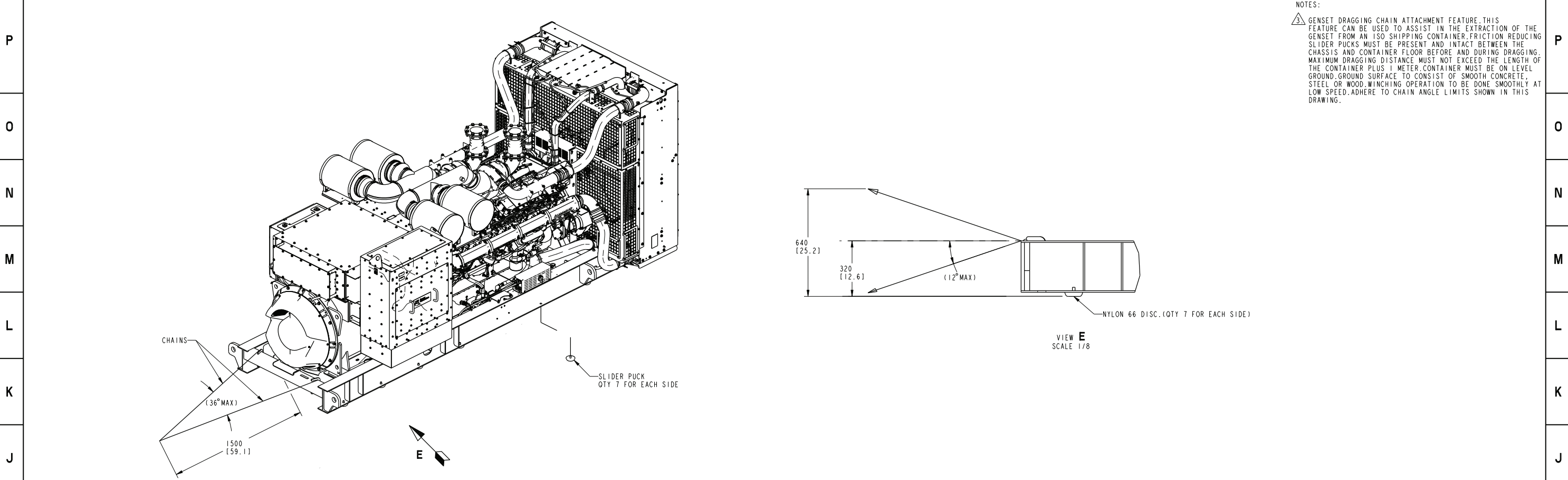

3 VIEW TO SHOW DRAGGING DETAILS FOR THE REMOVAL OF THE GENSET FROM AN ISO CONTAINER.

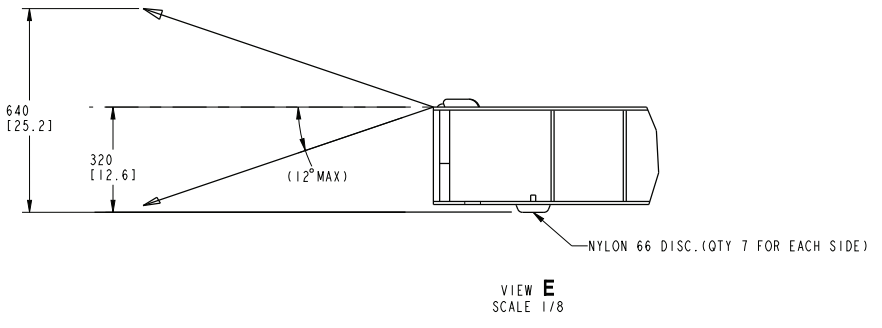

NOTES:
 3 GENSET DRAGGING CHAIN ATTACHMENT FEATURE. THIS FEATURE CAN BE USED TO ASSIST IN THE EXTRACTION OF THE GENSET FROM AN ISO SHIPPING CONTAINER. FRICTION REDUCING SLIDER PUCKS MUST BE PRESENT AND INTACT BETWEEN THE CHASSIS AND CONTAINER FLOOR BEFORE AND DURING DRAGGING. MAXIMUM DRAGGING DISTANCE MUST NOT EXCEED THE LENGTH OF THE CONTAINER PLUS 1 METER. CONTAINER MUST BE ON LEVEL GROUND. GROUND SURFACE TO CONSIST OF SMOOTH CONCRETE, STEEL OR WOOD. WINCHING OPERATION TO BE DONE SMOOTHLY AT LOW SPEED. ADHERE TO CHAIN ANGLE LIMITS SHOWN IN THIS DRAWING.

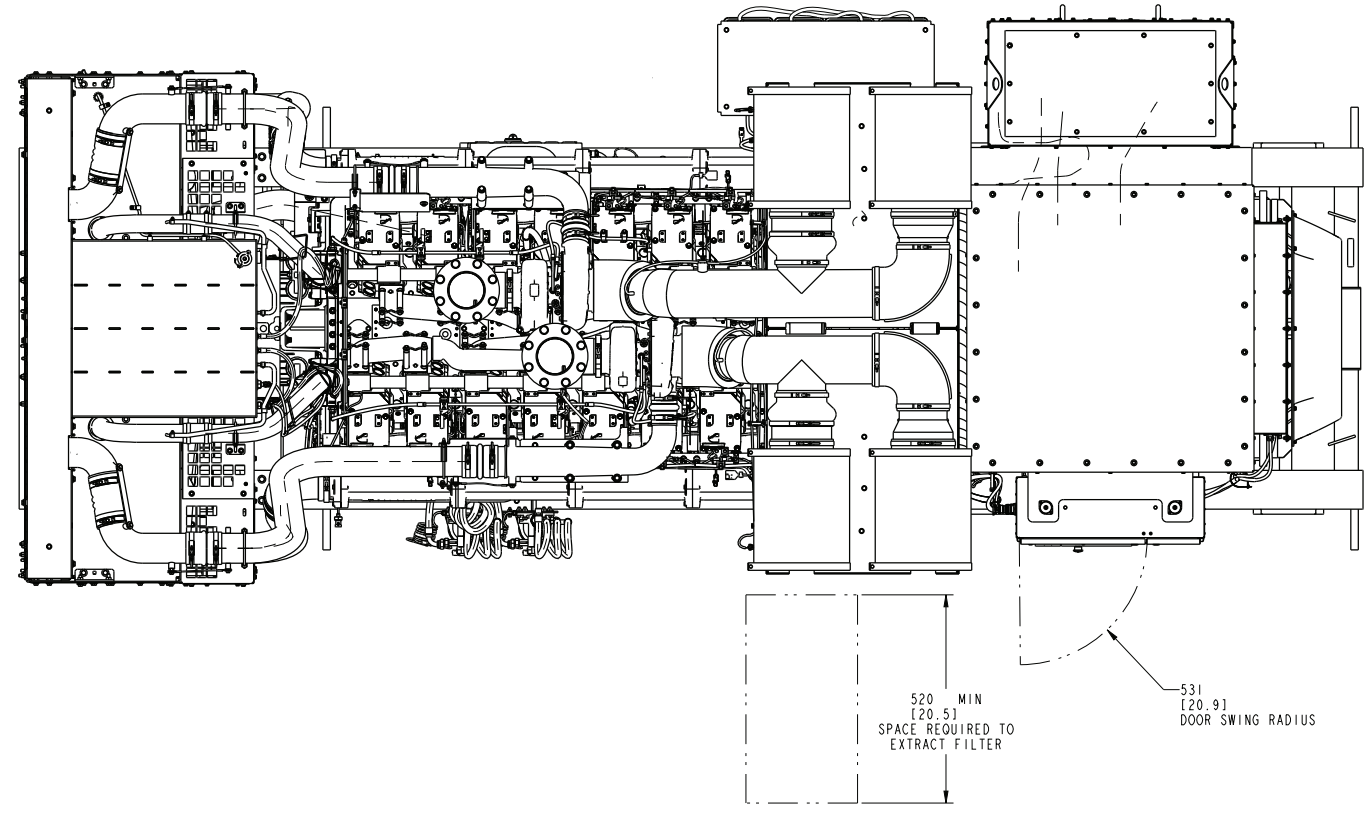

FOR ALL CONFIGURATIONS WITH CONTROL PANEL AND NORMAL DUTY AIR FILTER
 TOP VIEW - S9 ALTERNATOR VIEW SHOWN FOR REFERENCE
 SCALE 3/32

| | |
|--------------------------------------------------------------------------------------------------------------------------------------------------------------------------------------------------------------------------------------------------|------------------|
| PART NUMBER: A060C089 | PART REVISION: D |
| PART NAME: OUTLINE GENSET | |
| DRAWING CATEGORY: DETAIL | |
| STATE: RELEASED | SHEET: 9 OF 10 |
| CUMMINS DATA CLASSIFICATION: CUMMINS CONFIDENTIAL | |
| THIS DOCUMENT (AND THE INFORMATION SHOWN THEREON) IS CONFIDENTIAL AND PROPRIETARY AND SHALL NOT BE DISCLOSED TO OTHERS IN HARD COPY OR ELECTRONIC FORM, REPRODUCED BY ANY MEANS, OR USED FOR ANY PURPOSE WITHOUT WRITTEN CONSENT OF CUMMINS INC. | |

| | |
|------------------------------------------------------|-------------------------------|
| LAST DATUM LETTER USED: - | LAST REFERENCE LETTER USED: E |
| MODEL/PLATFORM: OSK50 | THIS PART IS SIMILAR TO: - |
| UNLESS OTHERWISE SPECIFIED THE FOLLOWING SHALL APPLY | |
| SURFACE FINISH PER: - | SURFACE FINISH: - |
| WALL THICKNESS: - | EDGE RADIUS: - |
| DIMENSIONAL TOLERANCES: - | FILLET RADIUS: - |
| HOLE SIZE 0.00-4.99 | HOLE SIZE 5.00-9.99 |
| TOL. +0.15/-0.08 | TOL. +0.20/-0.10 |
| HOLE SIZE 10.00-17.49 | HOLE SIZE 17.50-24.99 |
| TOL. +0.25/-0.13 | TOL. +0.30/-0.13 |

Cummins Inc.

DIMENSIONS ARE IN: MILLIMETERS
 () ARE IN: INCHES

SIZE: A0 SCALE: 1/16

DIMENSIONING AND TOLERANCING PER: ASME Y14.5-2009

THIRD ANGLE PROJECTION

CAD SYSTEM: PTC® Creo® Parametric

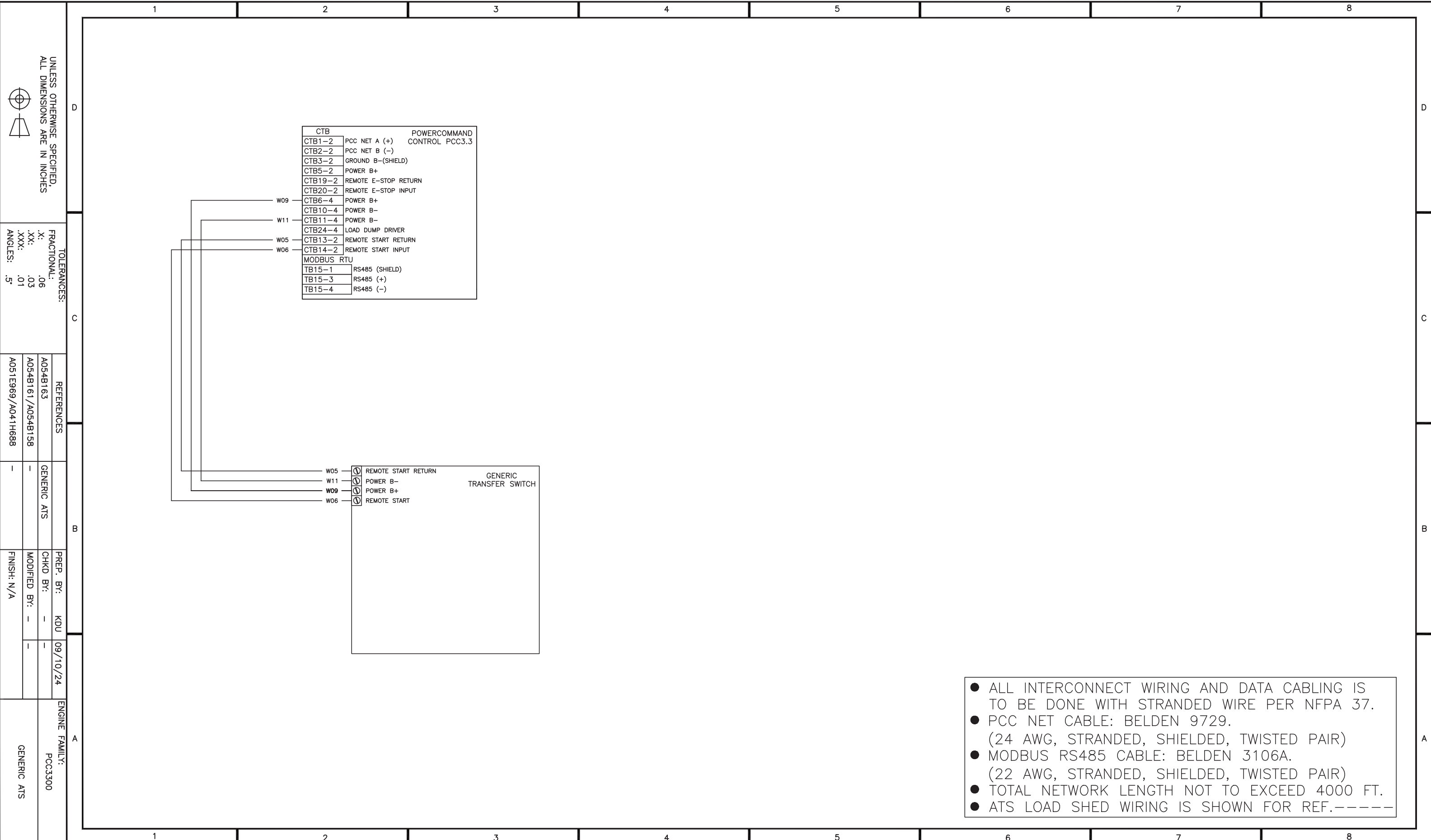

UNLESS OTHERWISE SPECIFIED,
ALL DIMENSIONS ARE IN INCHES

TOLERANCES:
FRACTIONAL:
X: .06
.XX: .03
.XXX: .01
ANGLES: .5°

REFERENCES
A054B163
A054B161/A054B158
A051E969/A041H688

GENERIC ATS

PREP. BY: KDU 09/10/24
CHKD BY: -
MODIFIED BY: -
FINISH: N/A

ENGINE FAMILY:
PCC3300
GENERIC ATS

- ALL INTERCONNECT WIRING AND DATA CABLING IS TO BE DONE WITH STRANDED WIRE PER NFPA 37.
- PCC NET CABLE: BELDEN 9729.
(24 AWG, STRANDED, SHIELDED, TWISTED PAIR)
- MODBUS RS485 CABLE: BELDEN 3106A.
(22 AWG, STRANDED, SHIELDED, TWISTED PAIR)
- TOTAL NETWORK LENGTH NOT TO EXCEED 4000 FT.
- ATS LOAD SHED WIRING IS SHOWN FOR REF.-----



| | | | | | | | | | | | |
|------------------|-----|---------------|-----|----------------------|-----|--------|-----------------------------------------------------|--------------------|---------------------|-----|------|
| SITE NAME: | --- | CONTACT NAME: | --- | CUSTOMER PROJECT NO: | --- | TITLE: | PCC3.3 CONTROL / GENERIC ATS QSK50..QSK60..QSK78 | | | | |
| CONTRACTOR NAME: | --- | CONTACT NO: | --- | CSSNA PROJECT NO: | --- | SCALE: | NONE | DO NOT SCALE PRINT | | | |
| | | | | | | SIZE: | B | DWG NO: | PCC3.3 INTERCONNECT | REV | --- |
| | | | | | | SCALE: | NONE | DO NOT SCALE PRINT | SHEET | 1 | OF 1 |

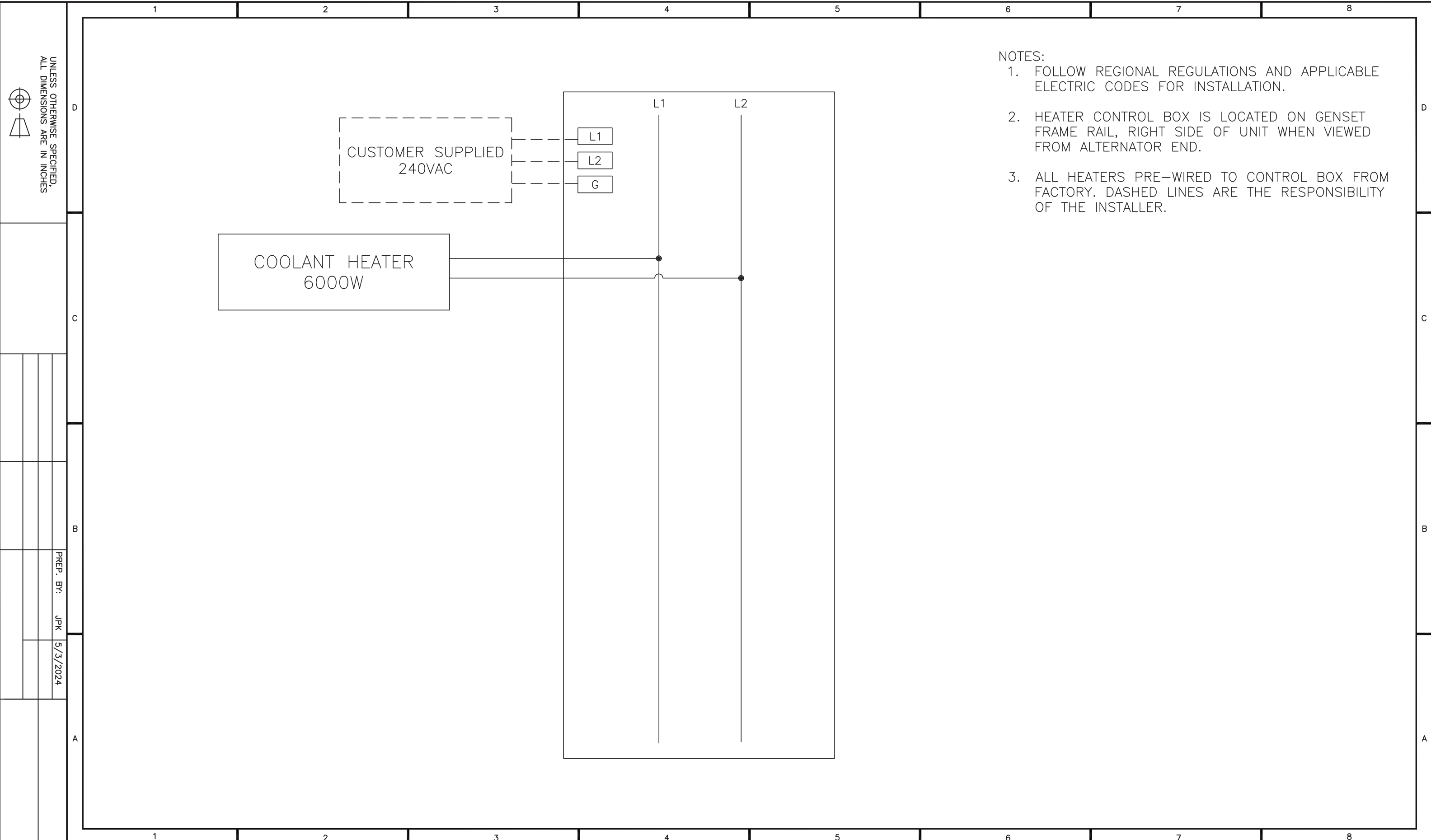

- NOTES:
1. FOLLOW REGIONAL REGULATIONS AND APPLICABLE ELECTRIC CODES FOR INSTALLATION.
 2. HEATER CONTROL BOX IS LOCATED ON GENSET FRAME RAIL, RIGHT SIDE OF UNIT WHEN VIEWED FROM ALTERNATOR END.
 3. ALL HEATERS PRE-WIRED TO CONTROL BOX FROM FACTORY. DASHED LINES ARE THE RESPONSIBILITY OF THE INSTALLER.

UNLESS OTHERWISE SPECIFIED,
ALL DIMENSIONS ARE IN INCHES



PREP. BY: JPK
5/3/2024

SECTION 5
START-UP & WARRANTY





Cummins Sales and Service Customer / Contractor Pre Commissioning Inspection Form

The intent of this form is for the contractor to prepare for equipment to be commissioned by a certified Cummins Field Service Power Generation Technician. Filling out this form is required and will minimize delays due to equipment failing to meet requirements. Completing this checklist in its entirety should minimize the need for additional billing beyond the previously provided commissioning quote.

The items listed are the responsibility of the contractor and not Cummins Sales and Service.

Project Name/End User: _____

Contractor: _____

Address: _____ Contact: _____

Business Phone: _____ Cell Phone: _____

Email: _____

ON SITE INFORMATION

On-Site Contact Information: _____

Address: _____

Time Requested Onsite: _____

Sub location of Generator (ie. Roof, basement, floor): _____

Does the facility have the following: Loading Dock Elevator

Access (from truck and load bank parking to generator in feet): _____

Parking: Is parking available on-site for service truck: Yes No

Permits: Have all necessary air quality and local permits been secured: Yes No N/A

Fuel Tank Testing: Is fuel tank testing required: Yes No

 If yes when is the inspector scheduled for: _____

ON SITE INFORMATION CONTINUED

| YES | NA | NO |
|-----|----|----|
| | | |
| | | |
| | | |

Is the facility occupied and is customer aware there will be power outages after generator is started?

Will there be any site safety training needed for technician prior to beginning? On site contact for training: _____

Will customer representative be on site for operator training?
On site contact for operator training: _____

MECHANICAL LOCATION AND PLACEMENT OF THE GENERATOR SET

| YES | NA | NO |
|-----|----|----|
| | | |
| | | |
| | | |
| | | |

Generator is properly secured to pad or vibration isolators

Generator Enclosure and/or Room is free of all debris

No airflow obstructions to the engine or generator are present for cooling combustion
(See Cummins T-030 or Installation manual of generator set)

Room is designed for adequate inlet and outlet airflow

GASEOUS FUEL Natural Gas/LP Vapor/LP Liquid

| YES | NA | NO |
|-----|----|----|
| | | |
| | | |
| | | |
| | | |

Natural gas and/or LPG fuel supply is connected.

Fuel piping is the appropriate size based on full-load CFH/BTU requirement. Pipe size after service regulator: _____

Service regulator(s), (if supplied), fuel strainer(s), flexible fuel line(s) and manual shut off are installed

Fuel pressure after service regulator is: _____ inches of H2O

I have read and fully understand the fuel requirements for this equipment, I am verifying that the piping and fuel supply meets or exceeds those requirements. I also understand failure to meet the requirements will result in additional charges.

Contractor "requestor" Signature

Date

DIESEL FUELED GENERATORS

YES NA NO

| | | |
|--|--|--|
| | | |
| | | |
| | | |
| | | |

Flexible fuel connections, (supply and return) are connected to generator and piping.

Day tank installed, wired and plumbed (lines free of obstruction) to genset and main fuel tank if applicable. Only black iron pipe for fuel lines, never use copper or galvanized pipe.

All tanks filled with enough fuel to perform startup and testing.

A return line from engine to day tank and day tank to main tank should be in place

EXHAUST SYSTEM

YES NA NO

| | | |
|--|--|--|
| | | |
| | | |
| | | |
| | | |

Exhaust wrapped or isolated to prevent accidental activation of fire protection devices and sprinklers.

Exhaust flex-pipe is installed at engine exhaust outlet (The silencer and flex-pipe are supplied with the generator set).

Silencer is installed with appropriate supports (no weight should be placed on the exhaust outlet of the genset).

Exhaust system has proper expansion joints and wall thimbles (Thimbles are required for wall or roof penetration).

GENERATOR ELECTRICAL CONNECTIONS

YES NA NO

| | | |
|--|--|--|
| | | |
| | | |
| | | |
| | | |
| | | |
| | | |
| | | |
| | | |
| | | |

Load conductors connected to breakers

Flexible connections used on all conduit connections to the generator set output box

Remote start interconnection **stranded** wiring is installed between the generator set and the automatic transfer switch(s) and annunciator.

AC Power conductors in dedicated conduit separate from any DC control or network wiring

Ground fault connected/functioning on generator, if supplied

AC power wired to the coolant heaters (Do NOT energize)

Check for AC oil pan heater, control heater or generator winding heater (Needing AC wiring)

Generator is grounded in compliance with local codes

If applicable, louver motors are operational and connected to generator controls

GENERATOR ELECTRICAL CONNECTIONS CONTINUED

YES NA NO

| | | |
|--|--|--|
| | | |
| | | |
| | | |

Where is annunciator located? _____

Are there additional ancillary devices/equipment that need to be integrated into the system? If yes, please define _____

Battery charger mounted (free of vibration, weather, accessible for an operator to observe easily) and connected to the appropriate AC and DC wiring to operate the charger.

TRANSFER SWITCH ELECTRICAL CONNECTIONS

YES NA NO

| | | |
|--|--|--|
| | | |
| | | |
| | | |

Conductors connected for Utility, Load and Emergency

Remote start interconnection **stranded** wiring is installed between the generator set and the automatic transfer switch(s).

Four Pole Transfer Switch: Is generator neutral grounded?

DAY OF STARTUP

YES NA NO

| | | |
|--|--|--|
| | | |
| | | |
| | | |

Training of facility personnel will be done on the same day as start up. Additional trips for operational training will be an additional charge.

Can transfer switch be tested at time of generator startup? (There will be a power interruption) **Note: After hours testing could result in additional charges.**

If the associated switchgear and/or ATS(s) are not provided by Cummins, will the manufacturer's representative be on site?

Exercise with or without load? _____

If known, Transfer Time delay set recommendations Generator Set to exercise Day: _____ Time: _____

Contractor "requestor" Signature

Printed Name

Date: _____

Please complete this form and return to schedule start up, if not returned within 5 business days prior to scheduled startup it may be delayed. I understand that the start-up date may have to be rescheduled at my expense if the above items have not been completed properly.



Warranty Statement

CENTUM™ Series Generator Set

C1250D6E, C1500D6E, C1750D6E,
C2000D6E, C2750D6E, C3000D6EB

Limited Warranty

CENTUM™ Series Generator Set

This limited warranty applies to all Cummins Inc. branded CENTUM™ Series generator sets including C1250D6E, C1500D6E, C1750D6E, C2000D6E, C2750D6E, and C3000D6EB and associated accessories (hereinafter referred to as "Product").

This warranty covers any failures of the Product, under normal use and service, which result from a defect in material or factory workmanship.

Warranty Period:

The warranty start date[†] is the date of initial start up, first rental, demonstration or 18 months after factory ship date, whichever is sooner. See table for details.

Continuous Power (COP) is defined as being the maximum power which the generating set is capable of delivering continuously whilst supplying a constant electrical load when operated for an unlimited number of hours per year. No overload capability is available for this rating.

Prime Power (PRP) is defined as being the maximum power which a generating set is capable of delivering continuously whilst supplying a variable electrical load when operated for an unlimited number of hours per year. The permissible average power output over 24 hours of operation shall not exceed 70% of the PRP. For applications requiring permissible average output higher than stated, a COP rating should be used.

Limited-Time Running Power (LTP) is defined as the maximum power available, under the agreed operating conditions, for which the generating set is capable of delivering for up to 500 hours of operation per year.

Emergency Standby Power (ESP) is defined as the maximum power available during a variable electrical power sequence, under the stated operating conditions, for which a generating set is capable of delivering in the event of a utility power outage or under test conditions for up to 3 years or 1,000 hours, whichever occurs first. The permissible average power output over 24 hours of operation shall not exceed 70% of the ESP.

Environmental Protection Agency – Stationary Emergency (EPA-SE) is defined as being the maximum power available during a variable electrical power sequence, under the stated operating conditions, for which a generator set is capable of delivering in the event of a utility power outage or under test conditions and used in strict accordance with the EPA NSPS for stationary engines, 40 CFR part 60, subparts IIII and JJJJ, where a reliable utility must be present. The permissible average power output over 24 hours of operation shall not exceed 70% of the EPA-SE.

Data Center Continuous (DCC) is defined as the maximum power which the generator is capable of delivering continuously to a constant or varying electrical load for unlimited hours in a data center application.

**Base Warranty Coverage Duration
(Whichever occurs first)**

| Rating | Months | Max. Hours |
|--------|--------|------------|
| COP | 12 | Unlimited |
| PRP | 12 | Unlimited |
| LTP | 12 | 500 hrs |
| ESP | 36 | 1000 hrs |
| EPA-SE | 24 | Unlimited |
| DCC | 24 | Unlimited |

[†] Warranty start date for designated rental and oil and gas model Products is determined to be date of receipt of Product by the end customer.

Cummins Inc. Responsibilities:

In the event of a failure of the Product during the warranty period due to defects in material or workmanship, Cummins Inc. will only be responsible for the following costs:

- All parts and labor required to repair the Product.
- Reasonable travel expenses to and from the Product site location.
- Maintenance items that are contaminated or damaged by a warrantable failure.

Owner Responsibilities:

The owner will be responsible for the following:

- Notifying Cummins Inc., its distributors or dealers within 30 days of the discovery of failure.
- Installing, operating, commissioning and maintaining the Product in accordance with Cummins Inc.'s published policies and guidelines.
- Providing evidence for date of commissioning.
- Providing sufficient access to and reasonable ability to remove the Product from the

installation in the event of a warrantable failure.

- Incremental costs and expenses associated with Product removal and reinstallation resulting from non-standard installations.
- Costs associated with rental of generating sets used to replace the Product being repaired.
- Costs associated with labor overtime and premium shipping requested by the owner.
- All downtime expenses, fines, all applicable taxes, and other losses resulting from a warrantable failure.

Limitations:

This limited warranty does not cover Product failures resulting from:

- Inappropriate use relative to designated power rating.
- Inappropriate use relative to application guidelines.
- Inappropriate use of an EPA-SE application generator set relative to EPA's standards.
- Normal wear and tear.
- Improper and/or unauthorized installation.
- Negligence, accidents or misuse.
- Lack of maintenance or unauthorized repair.
- Noncompliance with any Cummins Inc. published guideline or policy.
- Use of improper or contaminated fuels, coolants or lubricants.
- Improper storage before and after commissioning.
- Owner's delay in making Product available after notification of potential Product problem.
- Replacement parts and accessories not authorized by Cummins Inc.
- Use of Battle Short Mode.
- Owner or operator abuse or neglect such as: operation without adequate coolant or lubricants; overfueling; overspeeding; lack of maintenance to lubricating, cooling or air intake systems; late servicing and maintenance; improper storage, starting, warm-up, run-in or shutdown practices, or for progressive damage resulting from a defective shutdown or warning device.
- Damage to parts, fixtures, housings, attachments and accessory items that are not part of the generating set.

This limited warranty does not cover costs resulting from:

- Difficulty in gaining access to the Product.
- Damage to customer property.

A "Data center" is defined as a dedicated facility that house computers and associated equipment for data storage and data handling.

Reliable utility is defined as utility power without routine or regularly scheduled black-outs.

Please contact your local Cummins Inc. Distributor for clarification concerning these limitations.

CUMMINS INC. RIGHT TO FAILED COMPONENTS:

Failed components claimed under warranty remain the property of Cummins Inc. Cummins Inc. has the right to reclaim any failed component that has been replaced under warranty.

Extended Warranty:

Cummins Inc. offers several levels of Extended Warranty Coverage. Please contact your local Cummins Inc. Distributor for details.

power.cummins.com

THE WARRANTIES SET FORTH HEREIN ARE THE SOLE WARRANTIES MADE BY CUMMINS INC. IN REGARD TO THE PRODUCT. CUMMINS INC. MAKES NO OTHER WARRANTIES, EXPRESS OR IMPLIED, OR OF MERCHANTABILITY OR FITNESS FOR A PARTICULAR PURPOSE.

IN NO EVENT IS CUMMINS INC. LIABLE FOR INCIDENTAL OR CONSEQUENTIAL DAMAGES.

This limited warranty shall be enforced to the maximum extent permitted by applicable law. In the United States, some states do not allow limitations on how long an implied warranty lasts or the exclusion or limitation of incidental or consequential damages, so the above limitation or exclusion may not apply to you. This warranty gives you specific legal rights, and you may have other rights which vary from state to state or jurisdiction to jurisdiction.

Product Model Number: _____
Product Serial Number: _____
Date in Service: _____

power.cummins.com

Copyright © 2024 Cummins Inc. All rights reserved.

Cummins, the "C" logo, Centum, PowerCommand, AmpSentry, and InPower are trademarks of Cummins Inc. Other company, product, or service names may be trademarks or service marks of others. Specifications are subject to change without notice.

