

TRANSFER SWITCH DETAILS									
ATS NAME	QTY	AMPS / POLES (VOLTS)	BYPASS	TRANSITION TYPE	CATALOG NUMBER	ACCESSORIES	OUTLINE DRAWING	WIRING DIAGRAM	BOM NUMBER
	9	0600 / 4 (208V)	N/A	OPEN	J03ATSB30600CGXF	11BE	1001393-002	978745	1054543

Transfer Switch Withstand and Closing Ratings																						
300, 4000 & 7000 Series																						
ATS NAME	FRAME SIZE	SWITCH RATING AMPS		CURRENT LIMITING FUSES				SPECIFIC BREAKER			TIME BASED				Short Time Ratings ³ (sec)							
		Transfer Switches	Bypass Switches	480V Max.	600V Max.	MAX SIZE, A	CLASS	240V Max.	480V Max.	600V Max.	Time(Sec)	240V Max.	480V Max.	600V Max.	480V Max.				600V Max.			
															.13	.2	.3	.5	.1	.13	.3	.5
-	J	600	600	200kA	200kA	800	L	200kA	200kA	100kA	0.05	65kA	42kA ⁶	35kA	7.5kA ⁸	-	-	-	-			
-	H	800 - 1200	800 - 1200	200kA	200kA	1600 ⁴	L	65kA	150kA	65kA	0.05	50kA	50kA	50kA	36kA	-	36kA	-				
-	G ⁵	1600 - 2000	1600 - 2000	200kA	200kA	3000	L	200kA	200kA	100kA	0.05	100kA	100kA	100kA	42kA	36kA	42kA	-				
-	J	400	400	200kA	200kA	600	J	200kA	200kA	100kA	0.05	65kA	42kA ⁶	35kA	7.5kA	-	-	-				
-	J	400	400	200kA	200kA	800	L	200kA	200kA	100kA	0.05	65kA	42kA ⁶	35kA	7.5kA	-	-	-				

NOTES:

- 1) All WCR values indicated are tested in accordance with the requirements of UL 1008, 7th Edition.
- 2) Application requirements may permit higher WCR for certain switch sizes.
- 3) Short Time ratings are provided for applications involving circuit breakers that utilize trip delay settings for system selective coordination
- 4) Max fuse rating is 1200A on front connected H frame switches
- 5) Switches utilizing overlapping neutral (code "C") have 35kA, 0.050 Sec time-based rating at 480V Max
- 6) Rating shown is for Bypass switches only, Transfer Switch rating is 100kA
- 8) These frames are only available on the 7000 Series product
- 9) Short Time Rating applies to 600A Bypass switch only, the 600A Transfer Switch does not have a Short Time Rating

Transfer Switch Details

#3	ATS	AMPS: 0600	QTY: 9
Product	: Series 300	Catalog Number	: J03ATSB30600CGXF
Service Voltage / Hz	: 208V/60Hz	Optional Accessories	: 11BE
Bypass Isolation	: Not Applicable	Product Description	: 300 Series, Automatic Open Transition Transfer Switch
No. of Switched Poles: 4	: 4	Neutral Configuration	: Switched [B]
Withstand Rating:	: See WCR Table Below	No. of Cables & Lug Size	: 2, 1/0 AWG to 600 MCM
Frame = J, Switch Rating = 0600, Series = 300			
Enclosure	: 3R(F)-UL Type 3R Enclosure (See Disclaimer 3)	Service	: Three Phase, 4-wire
Extended Warranty	: Not Included	Markings	:

#	ACCESSORY DESCRIPTIONS	
	Accessory Code	Description
1	11BE	Adds the following features to the Group G controller: (1) Serial RS-485 Modbus Communications (2) Multi-Schedule Engine Exerciser (3) a 300 Entry Event Log and (4) a common alarm output function. When applied on 3-phase systems it also enables: (1) 3-Phase Emergency Source VLL sensing (2) Phase Rotation Monitoring (3) Emergency Source VLL Unbalance Monitoring.

OUTLINE FOR ASCO® 300 SERIES 600 AMPERE "J" FRAME (3ATS,3NTS), 150-600 AMPERE (3ADTS,3NDTS) FRONT CONNECTED TRANSFER SWITCHES TYPE 3R/12 ENCLOSURE

GENERAL NOTES

- TYPE 3R/12 ENCLOSURE. FREE STANDING. FLOOR OR WALL MOUNTABLE. 14 GAUGE CONSTRUCTION.
- THREE POINT LATCHING DOOR WITH LOCKABLE HANDLE.
- FINISH: ANSI 61 GRAY, POLYESTER POWDER STANDARD. OTHER ANSI COLORS AVAILABLE CONSULT FACTORY UL RECOGNIZED.
- RECOMMENDED CLEARANCES:
FRONT: 24 INCHES
- A 20% RATED GROUND BUS IS PROVIDED.
- UNIT IS DESIGNED FOR COMBINATION TOP AND BOTTOM CABLE ENTRY. THE STANDARD SWITCH CONFIGURATION IS FOR TOP LUGS EMERGENCY AND LOAD AND BOTTOM LUGS NORMAL. OPTIONALLY, THE SWITCH MAY BE SUPPLIED WITH REVERSE NORMAL & EMERGENCY LUGS. (REFER TO THE WIRING DIAGRAM FURNISHED WITH EACH TRANSFER SWITCH TO DETERMINE TERMINATION POSITIONS).
- A FULL RATED NEUTRAL CONNECTION FOR EACH SOURCE AND THE LOAD IS OPTIONAL. WHEN PROVIDED IT IS IN ONE OF THE FOLLOWING FORMATS AS SPECIFIED BY THE CATALOG NO. NEUTRAL TYPE:
A. SOLID (COPPER BUS) NEUTRAL
B. SWITCHED NEUTRAL POLE
C. OVERLAPPING NEUTRAL POLE (NOT AVAILABLE ON 7ACTS/ADTS UNITS)
-  CENTER OF GRAVITY.

CABLING NOTES

- ALL SIZES SUPPLIED STANDARD WITH MECHANICAL (SCREW TYPE) LUGS. (SEE AMP SIZE BELOW)
A. LUG MATERIAL: ALUMINUM ALLOY 6061-T6 WITH ELECTRO TIN PLATED FINISH.
B. SCREW MATERIAL: ALUMINUM ALLOY 6262-T9 WITH ELECTRO TIN PLATED FINISH.
C. UL LISTED, CSA CERTIFIED.
D. LUG SCREW TIGHTENING TORQUE PER UL 486B: 19 FT-LBS.
E. SUITABLE WIRE BENDING SPACE IS PROVIDED. (SEE AMP SIZE BELOW)
- GROUND LUGS ARE PROVIDED STANDARD AS FOLLOWS. (SEE AMP SIZE BELOW).
- CUSTOMER TERMINAL BLOCKS:
FOR ALL 300 SERIES 3ADTS, 3NDTS UNITS THE TB WILL BE MOUNTED ON THE UPPER RIGHT INSIDE OF ENCLOSURE. FOR 3ATS AND 3NTS UNITS TB WILL BE MOUNTED ON THE TRANSFER SWITCH FRAME AS INDICATED.

NOTES 150-400 AMP SWITCHES

- SUPPLIED WITH STANDARD MECHANICAL (SCREW TYPE) LUGS ON THE NORMAL, EMERGENCY & LOAD BUS STABS. ONE (1) LUG PER PHASE AND NEUTRAL EACH SUITABLE FOR CONNECTION OF TWO (2) 1/0 -250MCM CU/AL CABLES OR ONE (1) #4 -600MCM CU/AL CABLE.
A. SUITABLE WIRE BENDING SPACE IS PROVIDED FOR UP TO ONE (1) 600MCM CABLE PER TERMINAL PER NEC.
- GROUND LUGS ARE PROVIDED STANDARD AS FOLLOWS;
SIX (6) 1/0 -250MCM CU/AL CABLES OR THREE (3) #4 -600MCM CU/AL CABLE CONNECTIONS.

NOTES 600 AMP SWITCHES

- SUPPLIED WITH STANDARD MECHANICAL (SCREW TYPE) LUGS ON THE NORMAL, EMERGENCY & LOAD BUS STABS. ONE (1) LUG PER PHASE AND NEUTRAL EACH SUITABLE FOR CONNECTION OF TWO (2) #2 -600MCM CU/AL CABLES.
A. SUITABLE WIRE BENDING SPACE IS PROVIDED FOR UP TO TWO (2) 600MCM CABLE PER TERMINAL PER NEC.
- GROUND LUGS ARE PROVIDED STANDARD AS FOLLOWS;
SIX (6) #2 -600MCM CU/AL CABLE CONNECTIONS.

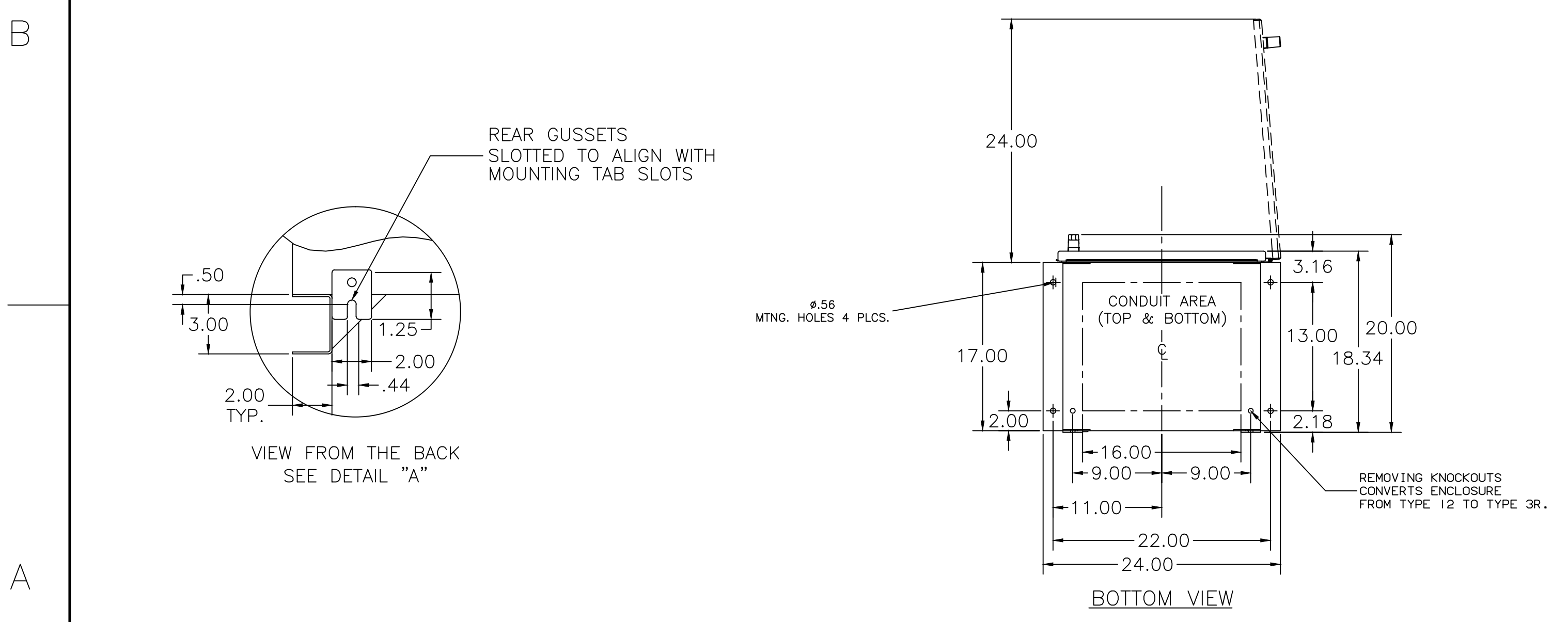
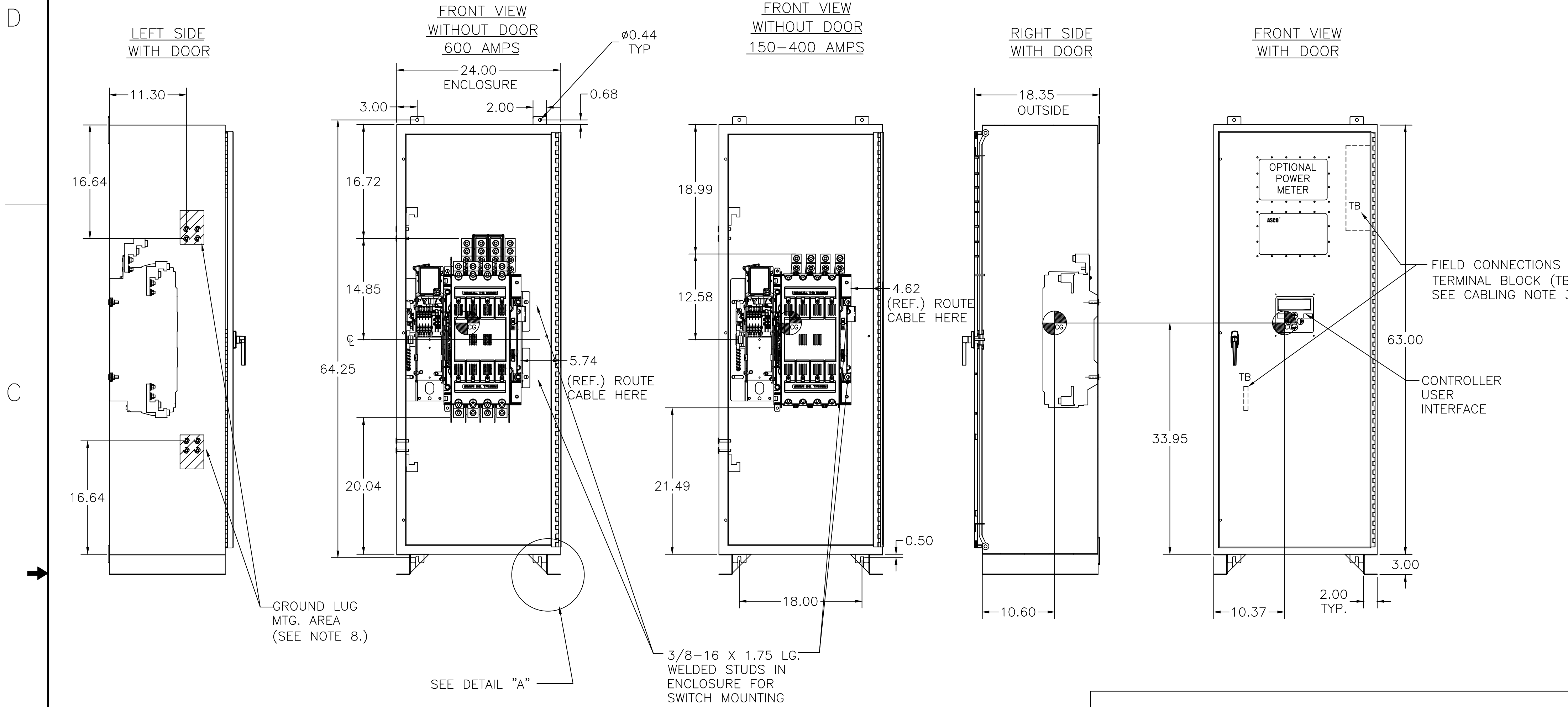

ATS SWITCH RATING (AMPS)	POLES	WEIGHTS LB (KG)
600	2	211 (96)
600	C2	N/A
600	3	215 (98)
600	C3	N/A
600	4	225 (102)

CTS/DTS SWITCH RATING (AMPS)	POLES	WEIGHTS LB (KG)
150-400	2	222 (101)
150-400	C2	N/A
150-400	3	228 (104)
150-400	C3	N/A
150-400	4	224 (102)
600	2	247 (112)
600	C2	N/A
600	3	234 (106)
600	C3	N/A
600	4	241 (109)

C	266871	TR	BK	5/2/17S
	SEE ECN			
B	263629	BK	TR	10/12/16
	SEE ECN			
A	249736	TR	WK	7/25/14
	SEE ECN			
-	245551	BK	BK	11/25/13
	ISSUED			

PROJECT NAME: **COMPOSITE** **OUTLINE**

300 SERIES TS "J"
J3ATS, J3NTS 600A, J3ADTS, J3NDTS 150-600 AMP TYPE 3R/12

MANUFACTURING TOLERANCES TO BE IN ACCORDANCE WITH ASCO PROCEDURE MP-1-003. FOR PLASTIC PARTS SEE MP-1-005.

PROPERTY OF ASCO POWER TECHNOLOGIES. USE PERMITTED FOR OUR WORK ONLY. ALL RIGHTS OF DESIGN OR INVENTION ARE RESERVED.

ASCO® ASCO POWER TECHNOLOGIES, L.P.
FLORHAM PARK, NEW JERSEY 07932 U.S.A.

1001393-002

SCALE: NONE SIZE: DS

DWG. NO. 1001393-002

DRAWING C ECN 266871 SHEET 1 OF 1

THREE PHASE WIRING FOR ASCO® 300 SERIES TRANSFER SWITCHES (J3ATS/J3NTS) 600 AMPERES WITH GROUP G CONTROLS

GENERAL INFORMATION

THIS WIRING APPLIES TO 300 SERIES TRANSFER SWITCHES THAT UTILIZE THE "J" FRAME POWER TRANSFER SWITCH RATED 600 AMPERES.

THE GROUP G CONTROLLER PROVIDES EITHER AUTOMATIC (J3ATS) OR NON-AUTOMATIC [MANUAL] (J3NTS) OPERATION BASED ON ITS FACTORY SETTING ACCORDING TO THE CUSTOMER ORDER REQUIREMENTS.

THE TYPE OF TRANSFER SWITCH PROVIDED CAN BE DETERMINED FROM THE PRODUCT IDENTIFICATION MARKINGS LOCATED ON BOTH THE POWER TRANSFER SWITCH AND THE COVER OF THE GROUP G CONTROLLER.

ALL OPERATIONAL SETTINGS AND SEQUENCES OF THE GROUP G CONTROLLER AND ITS RELATED OPTIONAL ACCESSORIES (1UP, 18RX, 23G) ARE PROVIDED IN THE USER'S GUIDE, ASCO GROUP G CONTROLLER FOR AUTOMATIC & NON-AUTOMATIC TRANSFER SWITCHES, PART NUMBER 381333-400.

INFORMATION FOR INSTALLATION AND TESTING OF THE TRANSFER SWITCH IS PROVIDED IN THE INSTALLATION MANUAL, ASCO 3ATS, 3ADTS, 3NTS & 3NDTS, J-DESIGN 150-600 A TRANSFER SWITCHES, PART NUMBER 381333-404.

COMMON ALARM & NOT IN AUTO SIGNALING FEATURES

A SET OF FORM C CONTACTS IS PROVIDED ON THE GROUP G CONTROLLER AS "OP1". THE FEATURE SETTING OF "OP1" CAN BE SET TO OPERATE THE CONTACTS AS A "NOT IN AUTO" SIGNAL.

WHEN "OP1" IS SET FOR "NOT IN AUTO", THE OUTPUT CONTACTS CHANGE POSITION WHEN THE TRANSFER IS BEING INHIBITED FROM TRANSFERRING TO THE EMERGENCY SOURCE (FEATURE 34B) OR THE TRANSFER SWITCH HAS BEEN SET FOR NON-AUTOMATIC (MANUAL) OPERATION.

WHEN OPTIONAL ACCESSORY 11BE "SOFTWARE BUNDLE" IS PART OF THE TRANSFER SWITCH ASSEMBLY, "OP1" MAY ALTERNATIVELY SET FOR A "COMMON ALARM" SIGNAL. THE OUTPUT CONTACTS CHANGE POSITION WHEN A "COMMON ALARM" IS NOT PRESENT AND RESET WHEN A "COMMON ALARM" CONDITION IS PRESENT. THE "COMMON ALARM" SIGNAL CONDITIONS ARE SELECTABLE.

ADDITIONAL "COMMON ALARM" AND "NOT IN AUTO" CONTACTS ARE AVAILABLE WHEN OPTIONAL ACCESSORY 18RX (RELAY EXPANSION MODULE) IS INCLUDED IN THE TRANSFER SWITCH ASSEMBLY. OUTPUT CONTACTS "OP2 AND/OR "OP3" WILL PROVIDE SIGNAL FUNCTIONS WHEN THE FEATURE SETTING OF EACH IS SET TO OPERATE AS "COMMON ALARM" OR "NOT IN AUTO".

CONTACTS ARE RATED 5 AMPS RESISTIVE AT 30 VDC MAXIMUM, 100 mA AT 5 VDC MINIMUM.

REFER TO USER'S GUIDE, ASCO GROUP G CONTROLLER FOR AUTOMATIC & NON-AUTOMATIC TRANSFER SWITCHES, PART NUMBER 381333-400 FOR SETTING INFORMATION.

NON-AUTOMATIC (MANUAL) OPERATION

TRANSFER SWITCH ASSEMBLIES FACTORY SET FOR NON-AUTOMATIC OPERATION PROVIDE USER INITIATED, ELECTRICAL OPERATION OF THE TRANSFER SWITCH TO EITHER AVAILABLE SOURCE. THE TRANSFER SWITCH ASSEMBLY IS PHYSICALLY IDENTICAL TO THAT OF THE AUTOMATIC TYPE.

WHEN THE TRANSFER SWITCH IS SET FOR NON-AUTOMATIC OPERATION, A CUSTOMER PROVIDED SELECTOR SWITCH MAY BE USED TO OPERATE IT FROM A REMOTE LOCATION.

REMOTE CONTROL FEATURES

THE FOLLOWING CONTROL PANEL INPUTS PROVIDE REMOTE CONTROL FUNCTIONS FOR THE TRANSFER SWITCH. EACH FUNCTION CAN BE IMPLEMENTED BY THE CUSTOMER PROVIDING THE FORM OF CONTROL DESCRIBED. EACH CONTROL CONTACT MUST BE SUITABLE FOR A 5 VDC LOW ENERGY CIRCUIT.

EXTERNAL FEATURE 17: REMOTE TRANSFER TO EMERGENCY FEATURE (FOR AUTOMATIC TRANSFER TYPE ONLY) - REQUIRES A CUSTOMER SUPPLIED, NORMALLY CLOSED CONTACT. OPENING OF THE CONTACT CAUSES ENGINE START AND TRANSFER TO THE EMERGENCY SOURCE. RE-CLOSURE OF THE CONTACT ACTIVATES THE FEATURE 3A "RETRANSFER TO NORMAL (IF JUST TEST) TIME DELAY PRIOR TO RETRANSFER. IN THE EVENT THAT THE EMERGENCY SOURCE FAILS WHILE THE TRANSFER SWITCH IS CONNECTED TO EMERGENCY AND THE CUSTOMER SUPPLIED CONTACT IS OPEN, THE TRANSFER SWITCH WILL AUTOMATICALLY RETRANSFER TO THE NORMAL SOURCE.

EXTERNAL FEATURE 6B: REMOTE BYPASS OF RETRANSFER TO NORMAL TIME DELAY - REQUIRES A CUSTOMER SUPPLIED, NORMALLY CLOSED CONTACT. OPENING OF THE CONTACT BYPASSES FEATURE 3A RETRANSFER TO NORMAL DELAY IF ACTIVE.

REFER TO USER'S GUIDE, ASCO GROUP G CONTROLLER FOR AUTOMATIC & NON-AUTOMATIC TRANSFER SWITCHES, PART NUMBER 381333-400 FOR SETTING INFORMATION.

ENGINE CONTROL CONTACTS

FEATURE 7 & FEATURE 8:
ONE SET OF FORM C CONTACTS "NR" (FEAT. 7 N/C, FEAT. 8 N/O) THAT CHANGE POSITION ON EXPIRATION OF THE FEATURE 1C, OVERRIDE MOMENTARY NORMAL SOURCE OUTAGES TIME DELAY, AND RESET ON EXPIRATION OF THE FEATURE 2E ENGINE COOLDOWN TIME DELAY. AN AUXILIARY CONTACT THAT IS CLOSED WHEN THE TRANSFER SWITCH IS CONNECTED TO THE EMERGENCY SOURCE, IS CONNECTED ACROSS THE N/C CONTACT (FEATURE 7).

AN ADDITIONAL SET OF ENGINE STARTING CONTACTS ARE AVAILABLE ON THE GROUP G CONTROLLER WHEN THE FEATURE SETTING OF THE CONTROLLER OUTPUT CONTACTS "OP1" IS SET TO OPERATE AS "NR2".

ADDITIONAL, OPTIONAL ENGINE STARTING CONTACTS "NR2" ARE AVAILABLE WHEN OPTIONAL ACCESSORY 18RX (RELAY EXPANSION MODULE) IS INCLUDED IN THE TRANSFER SWITCH ASSEMBLY. OUTPUT CONTACTS "OP2" AND/OR "OP3" PROVIDE THE ENGINE STARTING FUNCTION WHEN THE FEATURE SETTING OF EACH IS SET TO OPERATE AS "NR2".

CONTACTS ARE RATED 5 AMPS RESISTIVE AT 30 VDC MAXIMUM, 100 mA AT 5 VDC MINIMUM.

REFER TO USER'S GUIDE, ASCO GROUP G CONTROLLER FOR AUTOMATIC & NON-AUTOMATIC TRANSFER SWITCHES, PART NUMBER 381333-400 FOR SETTING INFORMATION.

EXTERNAL POWER SUPPLY COMPATIBILITY

USE OF AN EXTERNAL POWER SUPPLY IS USEFUL WHEN REQUIRED TO EXTEND THE FOLLOWING CONTROLLER TIME DELAYS BEYOND 6 SECONDS:

FEATURE 1C - OVERRIDE MOMENTARY NORMAL SOURCE OUTAGES
FEATURE 1F - OVERRIDE MOMENTARY EMERGENCY SOURCE OUTAGES

AN EXTERNAL POWER SUPPLY IS ALSO USEFUL WHEN THE TRANSFER SWITCH IS USED WITH COMMUNICATIONS FEATURES BY ENABLING THE CONTROLLER TO CONTINUE COMMUNICATING.

AN EXTERNAL POWER SOURCE MAY BE PROVIDED TO THE CONTROLLER, UNTIL THE NORMAL SOURCE OR EMERGENCY SOURCE IS AVAILABLE, BY USE OF:

- AN EXTERNAL 24 VDC POWER SUPPLY WITH ACCESSORY 18RX (RELAY EXPANSION MODULE)
- OR
- OPTIONAL ACCESSORY 1UP (UNINTERRUPTIBLE POWER SUPPLY MODULE)

LOAD DISCONNECT FEATURE

FEATURE 31: INCLUDES SUB-FEATURES 31F, 31G, 31M, 31N
A SET OF FORM C CONTACTS ARE PROVIDED ON THE GROUP G CONTROLLER AS "OP1". WHEN THE FEATURE SETTING OF "OP1" IS SET TO OPERATE THE CONTACTS AS "FEATURE 31", THE TIME DELAY SETTINGS OF THE SUB-FEATURES ARE AVAILABLE.

"OP1" CAN BE SET TO OPERATE TO PROVIDE THE FOLLOWING FUNCTIONS USING THE TIME DELAY SETTINGS ASSOCIATED WITH EACH SUB-FEATURE:

31F - NORMAL TO EMERGENCY PRE-TRANSFER SIGNAL
31G - EMERGENCY TO NORMAL PRE-TRANSFER SIGNAL
31M - NORMAL TO EMERGENCY POST-TRANSFER SIGNAL
31N - EMERGENCY TO NORMAL POST TRANSFER SIGNAL

THE "OP1" OUTPUT CONTACTS CHANGE POSITION FOLLOWING EACH OF THE ABOVE TIME DELAYS.

ADDITIONAL LOAD DISCONNECT CONTACTS, "FEATURE 31" ARE AVAILABLE WHEN OPTIONAL ACCESSORY 18RX (RELAY EXPANSION MODULE) IS INCLUDED IN THE TRANSFER SWITCH ASSEMBLY. OUTPUT CONTACTS "OP2 AND/OR "OP3" WILL PROVIDE LOAD DISCONNECT FUNCTIONS WHEN THE FEATURE SETTING OF EACH IS SET TO OPERATE AS "FEATURE 31".

ALL OUTPUT CONTACTS ("OP1", "OP2", "OP3") SET TO OPERATE AS "FEATURE 31", SHARE THE COMMON TIME DELAY SETTINGS OF SUB-FEATURES 31F, 31G, 31M, AND 31N.

CONTACTS ARE RATED 5 AMPS RESISTIVE AT 30 VDC MAXIMUM, 100 mA AT 5 VDC MINIMUM.

REFER TO USER'S GUIDE, ASCO GROUP G CONTROLLER FOR AUTOMATIC & NON-AUTOMATIC TRANSFER SWITCHES, PART NUMBER 381333-400 FOR SETTING INFORMATION.

EXTERNAL 24 VDC POWER SUPPLY "1G":

AN EXTERNAL 24 VDC POWER SUPPLY MAY BE USED TO POWER THE CONTROLLER WHEN ACCESSORY 18RX (RELAY EXPANSION MODULE) IS INCLUDED IN THE TRANSFER SWITCH ASSEMBLY. OUTPUT CONTACTS "OP2" WILL PROVIDE EXTERNAL 24 VDC POWER SUPPLY FUNCTIONALITY WHEN ITS FEATURE SETTING IS SET TO OPERATE AS "1G". ADDITIONALLY, JUMPERS MUST BE RECONFIGURED ON ACCESSORY 18RX (RELAY EXPANSION MODULE) TO ENABLE THIS FUNCTION AS FOLLOWS:

REMOVE JUMPERS "J1" 1-2 & "J1" 3-4
CONNECT JUMPERS "J1" 5-7 & "J1" 6-8

THE OUTPUT CONTACTS CHANGE POSITION WHEN EITHER THE NORMAL SOURCE OR EMERGENCY SOURCE IS AVAILABLE AND RESET WHEN NEITHER SOURCE IS AVAILABLE. THE "OP2" N/C CONTACT SWITCHES CUSTOMER PROVIDED +24 VDC FROM THE EXTERNAL POWER SUPPLY TO THE CONTROLLER.

REFER TO USER'S GUIDE, ASCO GROUP G CONTROLLER FOR AUTOMATIC & NON-AUTOMATIC TRANSFER SWITCHES, PART NUMBER 381333-400 FOR SETTING INFORMATION.

ACCESSORY 1UP (UNINTERRUPTIBLE POWER SUPPLY):
WHEN OPTIONAL ACCESSORY 1UP IS INCLUDED IN THE TRANSFER SWITCH ASSEMBLY, THE CONTROLLER IS PROVIDED WITH LIMITED RESERVE POWER (APPROXIMATELY 3 MINUTES).

INPHASE TRANSFER FEATURE FOR LOAD TRANSFER

INPHASE TRANSFER CONTROL INITIATES AN INPHASE TRANSFER OF LOADS BETWEEN LIVE SOURCES. THIS IS USED TO PREVENT NUISANCE TRIPPING OF DISTRIBUTION CIRCUIT BREAKERS AND POSSIBLE DAMAGE TO MECHANICAL LOADS ASSOCIATED WITH OUT OF PHASE TRANSFER.

REFER TO USER'S GUIDE, ASCO GROUP G CONTROLLER FOR AUTOMATIC & NON-AUTOMATIC TRANSFER SWITCHES, PART NUMBER 381333-400 FOR SETTING INFORMATION.

LOAD CURRENT METERING

WHEN OPTIONAL ACCESSORY 23GB IS PART OF THE TRANSFER SWITCH ASSEMBLY, THREE PHASE CURRENT MEASUREMENTS ARE AVAILABLE FOR DISPLAY ON THE GROUP G CONTROLLER.

REFER TO USER'S GUIDE, ASCO GROUP G CONTROLLER FOR AUTOMATIC & NON-AUTOMATIC TRANSFER SWITCHES, PART NUMBER 381333-400 FOR INFORMATION ON USE.

SOURCE AVAILABILITY SIGNALS

SIGNALS INDICATING THE AVAILABILITY OF THE NORMAL & EMERGENCY SOURCES IS PROVIDED WHEN OPTIONAL ACCESSORY 18RX (RELAY EXPANSION MODULE) IS INCLUDED IN THE TRANSFER SWITCH ASSEMBLY. OUTPUT CONTACTS "RL5" (EMERGENCY SOURCE AVAILABLE) AND "RL6" (NORMAL SOURCE AVAILABLE) CHANGE POSITION WHEN THE SOURCE IS ACCEPTABLE.

CONTACTS ARE RATED 5 AMPS RESISTIVE AT 30 VDC MAXIMUM, 100 mA AT 5 VDC MINIMUM.

ADVANCED-FUNCTION SOFTWARE BUNDLE

WHEN OPTIONAL ACCESSORY 11BE IS PART OF THE TRANSFER SWITCH ASSEMBLY, AN ADVANCED-FUNCTION SOFTWARE BUNDLE IS AVAILABLE TO PERFORM THE FOLLOWING FUNCTIONS:

- SERIAL COMMUNICATIONS (RS-485)
- PROGRAMMABLE ENGINE EXERCISER
- EVENT LOG
- COMMON ALARM SIGNAL CAPABILITY ON GROUP G CONTROLLER "OP1" OUTPUT.

(3 PHASE SENSING ONLY)
- 3 PHASE EMERGENCY SOURCE SENSING.
- PHASE ROTATION SENSING.
- EMERGENCY VOLTAGE UNBALANCE SENSING.

REFER TO USER'S GUIDE, ASCO GROUP G CONTROLLER FOR AUTOMATIC & NON-AUTOMATIC TRANSFER SWITCHES, PART NUMBER 381333-400 FOR INFORMATION ON THESE FUNCTIONS.

NOTES

1. SWITCH SHOWN DE-ENERGIZED CONNECTED TO NORMAL SOURCE.
2. DEVICE SYMBOLS AND DESIGNATIONS ARE IN ACCORDANCE WITH NEMA PUB. ICS 1, PART 1-101A.
3. ALL WIRING IS #16 AWG, TINNED, STRANDED COPPER UNLESS OTHERWISE INDICATED.
4. ○ INDICATES CUSTOMER CONNECTION POINTS.
4. ● INDICATES FACTORY CONNECTION POINTS.
5. CONNECTION POINTS THAT HAVE BOTH CUSTOMER CONNECTIONS AND FACTORY CONNECTIONS ARE SHOWN OPEN AS CUSTOMER CONNECTION POINTS.
6. THE TRANSFER UNIT IS MOUNTED ON THE BACK INSIDE SURFACE OF THE ENCLOSURE. THE CONTROL PANEL AND ANY OPTIONAL ACCESSORIES ARE MOUNTED ON THE INSIDE SURFACE OF THE DOOR.
7. AN OPERATOR'S MANUAL IS FURNISHED WITH EACH AUTOMATIC TRANSFER SWITCH. REFER TO THIS PUBLICATION PRIOR TO INSTALLATION AND OPERATION OF THE SWITCH.
8. GROUND STRAP ON CONTROL PANEL IS AFFIXED TO CHASSIS (ENCLOSURE) AT LOWER LEFT CONTROL PANEL MOUNTING STUD.

CATALOG NUMBER SUFFIXES								
TS FRAME	CATALOG TYPE	NEUTRAL TYPE	PHASE POLES	AMPS	VOLT CODE	CONTROLLER	OPTIONAL ACCESSORY	ENCLOSURE CODE
J	3ATS 3NTS	A B	3	600	C D E F G H J K L M N P Q R	G	X	C F G H L M N P Q
							BLANK FOR NONE	BLANK FOR OPEN TYPE

EXPLANATION OF CATALOG NUMBER CODES											
NEUTRAL TYPE			VOLTAGE CODES 3 PHASE (3 OR 4 WIRE) 50 OR 60 Hz			ENCLOSURE CODES					
CODE	DESCRIPTION		CODE	NOMINAL VOLTAGE		CODE	TYPE	DESCRIPTION			
A	SOLID SWITCHING	C	208	BLANK	C	1	1	OPEN TYPE (NO ENCLOSURE) GENERAL PURPOSE, INDOOR			
B		D	220					F	3R	OUTDOOR, RAINPROOF, SLEET & ICE RESISTANT	
		E	230	G	4			INDOOR/OUTDOOR, WATERTIGHT & DUSTTIGHT			
		F	240	H	4X			TYPE 4 PLUS CORROSION RESISTANCE (STAINLESS STEEL)			
		G	277	L	12			INDOOR, INDUSTRIAL ENVIRONMENTS, OILTIGHT & DUSTTIGHT			
		H	380			M	3R	(SECURE ENCLOSURES) OUTDOOR, RAINPROOF, SLEET & ICE RESISTANT			
		J	400			N	4	INDOOR/OUTDOOR, WATERTIGHT & DUSTTIGHT			
		K	415			P	4X	TYPE 4 PLUS CORROSION RESISTANCE (STAINLESS STEEL)			
		L	440			Q	12	INDOOR, INDUSTRIAL ENVIRONMENTS, OILTIGHT & DUSTTIGHT			
		M	460								
		N	480								
		P	550*								
		Q	575*								
		R	600*								

CATALOG NUMBER _____
ASCO® CERTIFIED TO
 S.O. _____
 BY _____
 DATE _____

FORM REV G

REV. TO SHEET	ECN NO.	BY	APP.	DATE

WIRING DIAGRAM

**300 SERIES J3ATS/J3NTS, THREE PHASE 600 AMPS
"J" FRAME, GROUP G CONTROLS**

THIRD ANGLE PROJECTION

DRAWN BY	SDH	DATE	5/6/13	MANUFACTURING TOLERANCES TO BE IN ACCORDANCE WITH ASCO PROCEDURE MP-1-003. FOR PLASTIC PARTS SEE MP-1-035	ASSEM. REF. NO.	COMPUTER GENERATED DRAWING
CHECKED				PROPERTY OF ASCO POWER TECHNOLOGIES. USE PERMITTED FOR OUR WORK ONLY. ALL RIGHTS OF DESIGN OR INVENTION ARE RESERVED.		SCALE
PROJECT APPROVAL						NO.
FINAL APPROVAL	SDH	5/6/13				SIZE
						DS
						DWG. NO.
						978745
						ECN NO. 278589
						SHEET 1 OF 6

ASCO® ASCO Power Technologies, L.P.
FLORHAM PARK, NEW JERSEY 07932 U.S.A.

G	278589	TR	BK	05/03/19
	SEE ECN			
F	275211	TR	BK	10/16/18
	SEE ECN			
E	266495	MKA	JPB	04/10/17
	SEE ECN			
D	251210	AJ	MM	10/17/14
	SEE ECN			
C	247770	SDH	SDH	4/14/14
	SEE ECN			
B	246325	AE	BK	01/16/14
	SEE ECN			
A	242580	SDH	SDH	5/30/13
	SEE ECN			
	242255	SDH	SDH	5/6/13
	ISSUE			

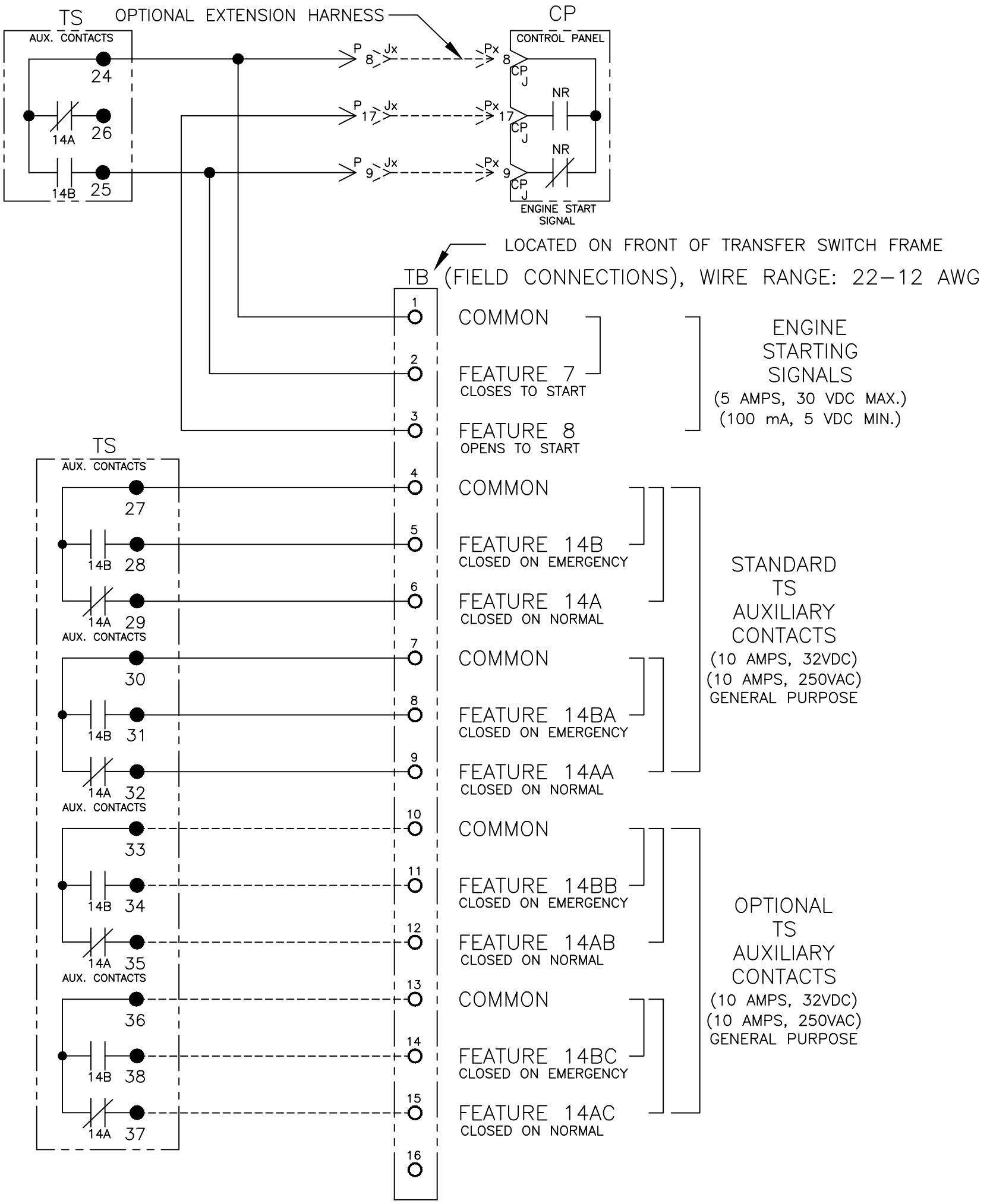

CONTROLLER OPTION RELAY "OP1" (STANDARD)

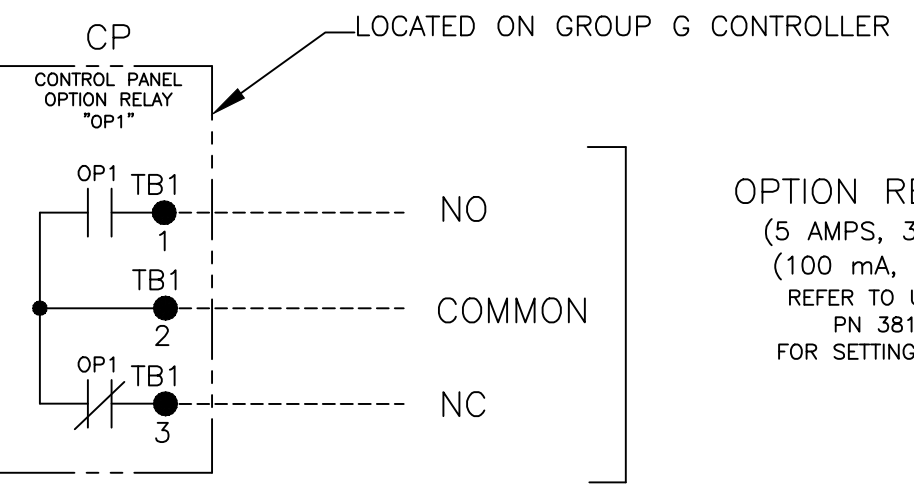

CONTROLLER REMOTE CONTROL FEATURES

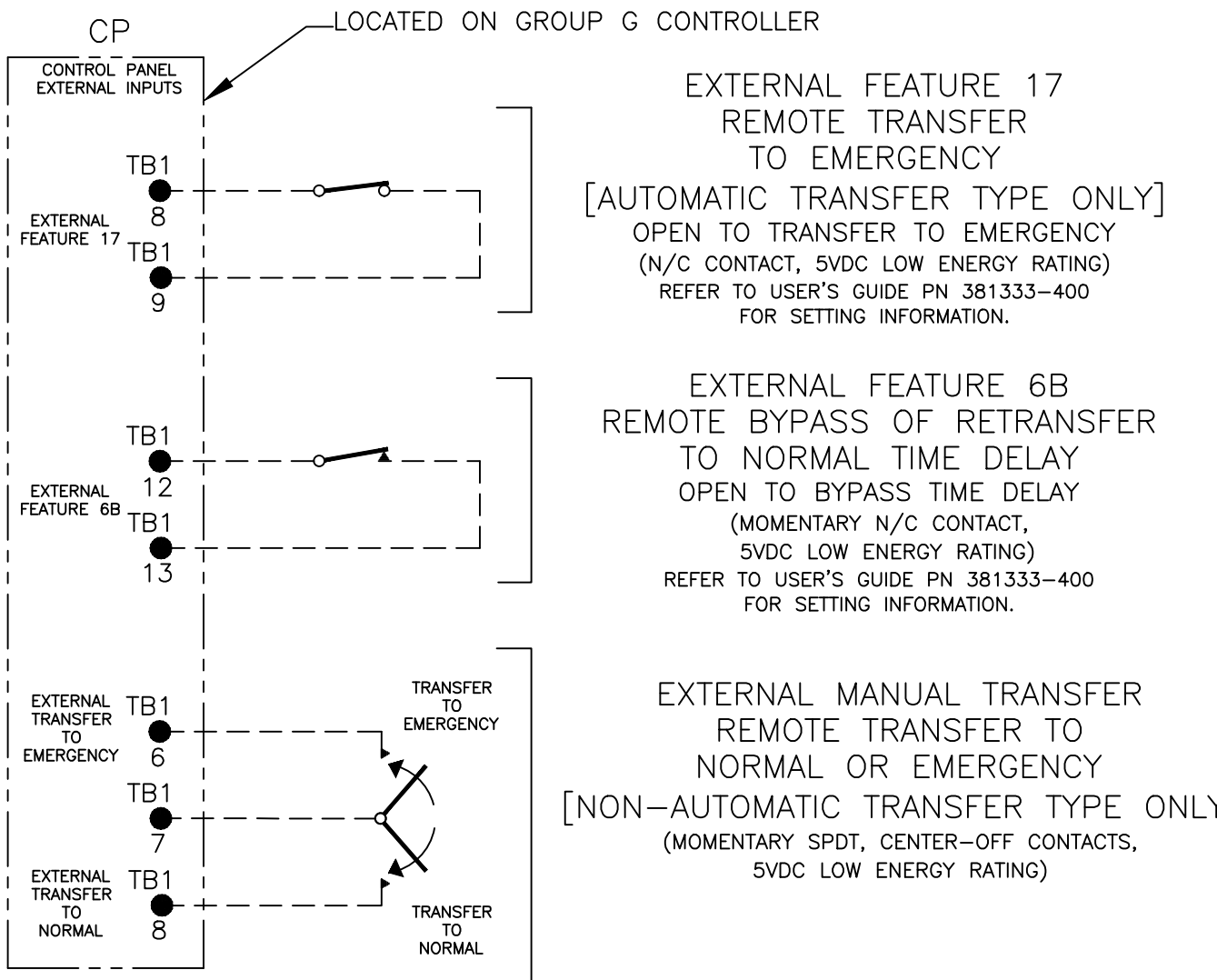

OPTIONAL ACCESSORY 18RX (RELAY EXPANSION MODULE)

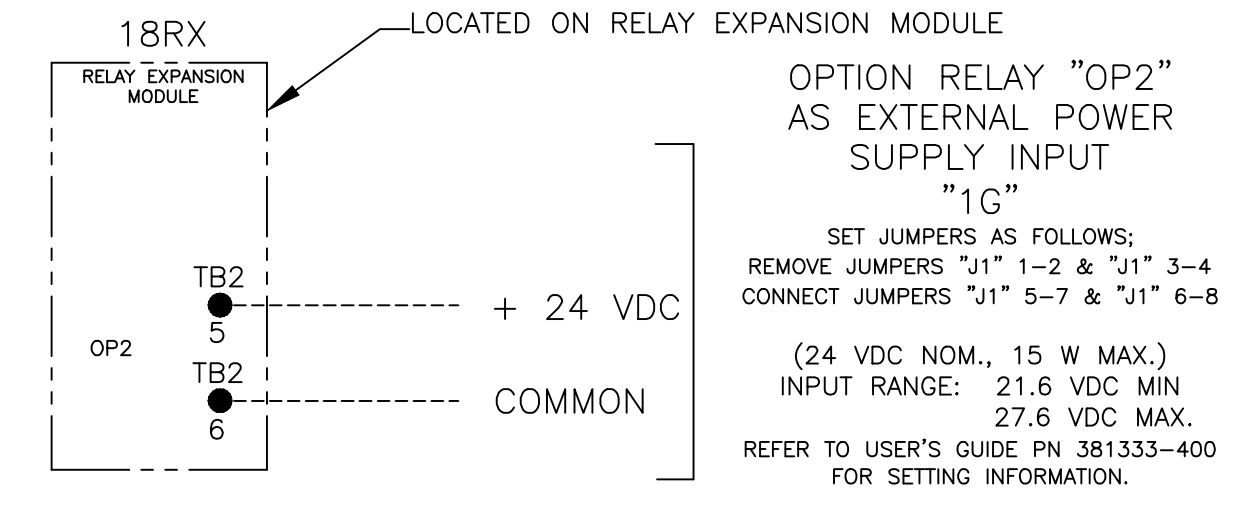
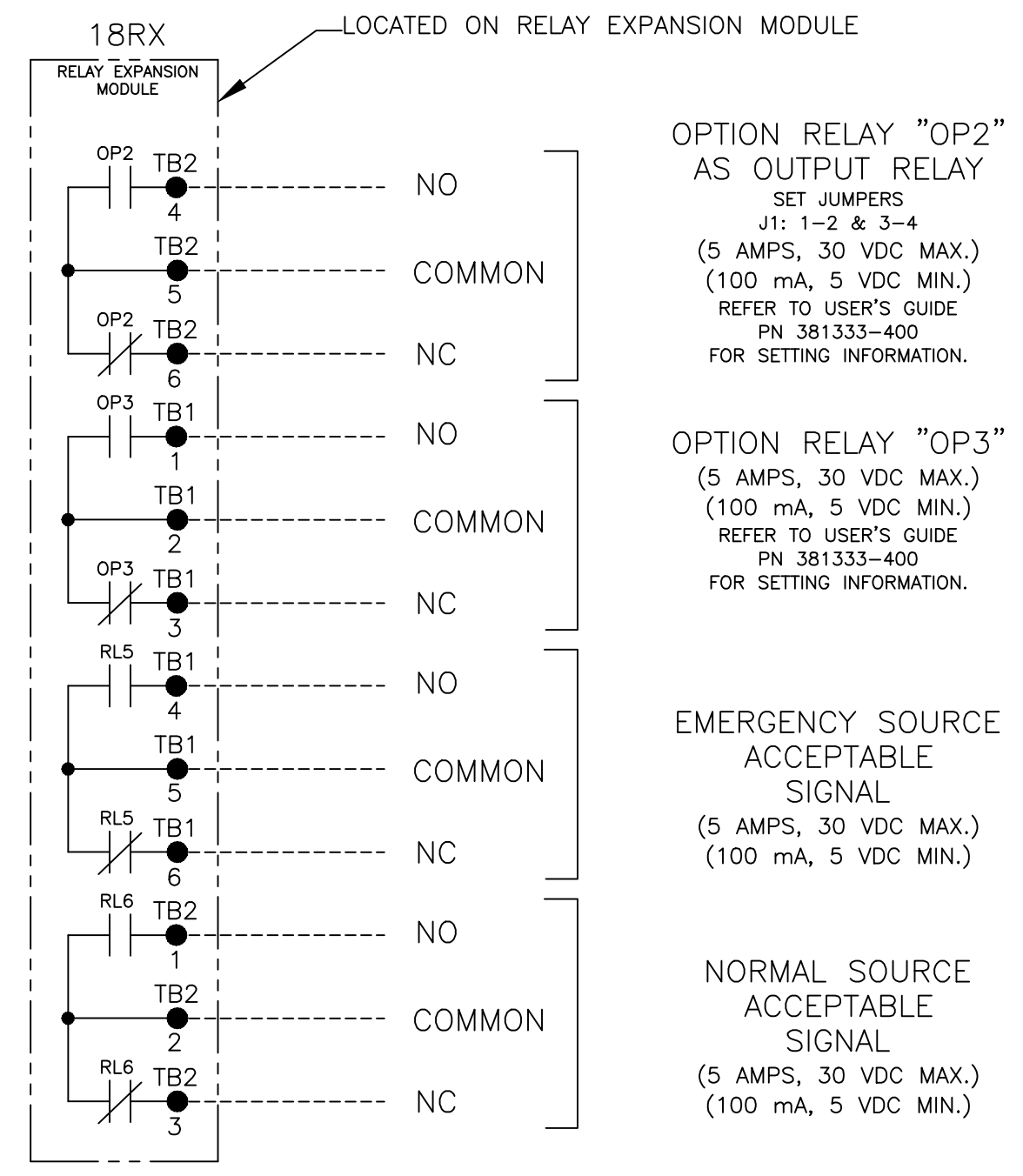

RS485 SERIAL COMMUNICATIONS OPTION
AVAILABLE WITH OPTIONAL ACCESSORY 11BE: ADVANCED-FUNCTION SOFTWARE BUNDLE
REFER TO USER'S GUIDE PN 381333-400 FOR SETTING INFORMATION.

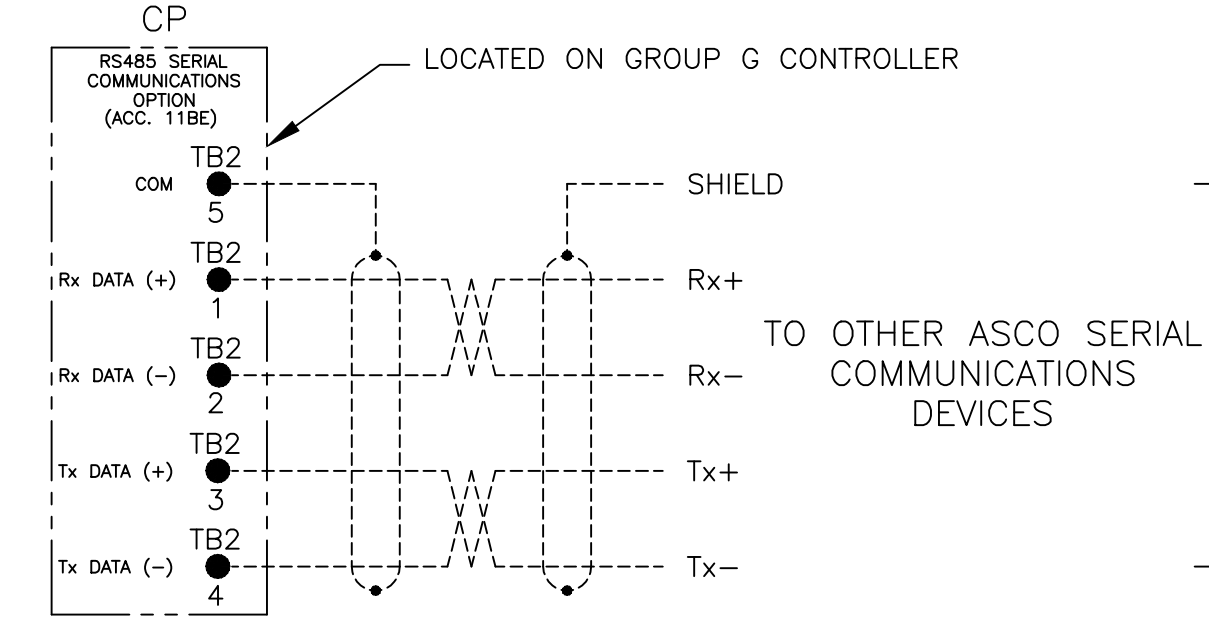

- NOTES:
- EARTH GROUND SHIELD AT HOST DEVICE ONLY.
 - FIELD WIRING: USE UL LISTED, STRANDED, TWISTED PAIRS, OVERALL FOIL SHIELD WITH STRANDED DRAIN WIRE SUITABLE FOR RS422 EQUIVALENT TO:
 - (STANDARD 80°C) BELDEN 9842 OR 9829 OR ALPHA 6202C OR 6222C
 - (PLENUM RATED) BELDEN 89729 OR 82729 OR ALPHA 58902

OPTIONAL ACCESSORY 18RX1 (SECOND RELAY EXPANSION MODULE)

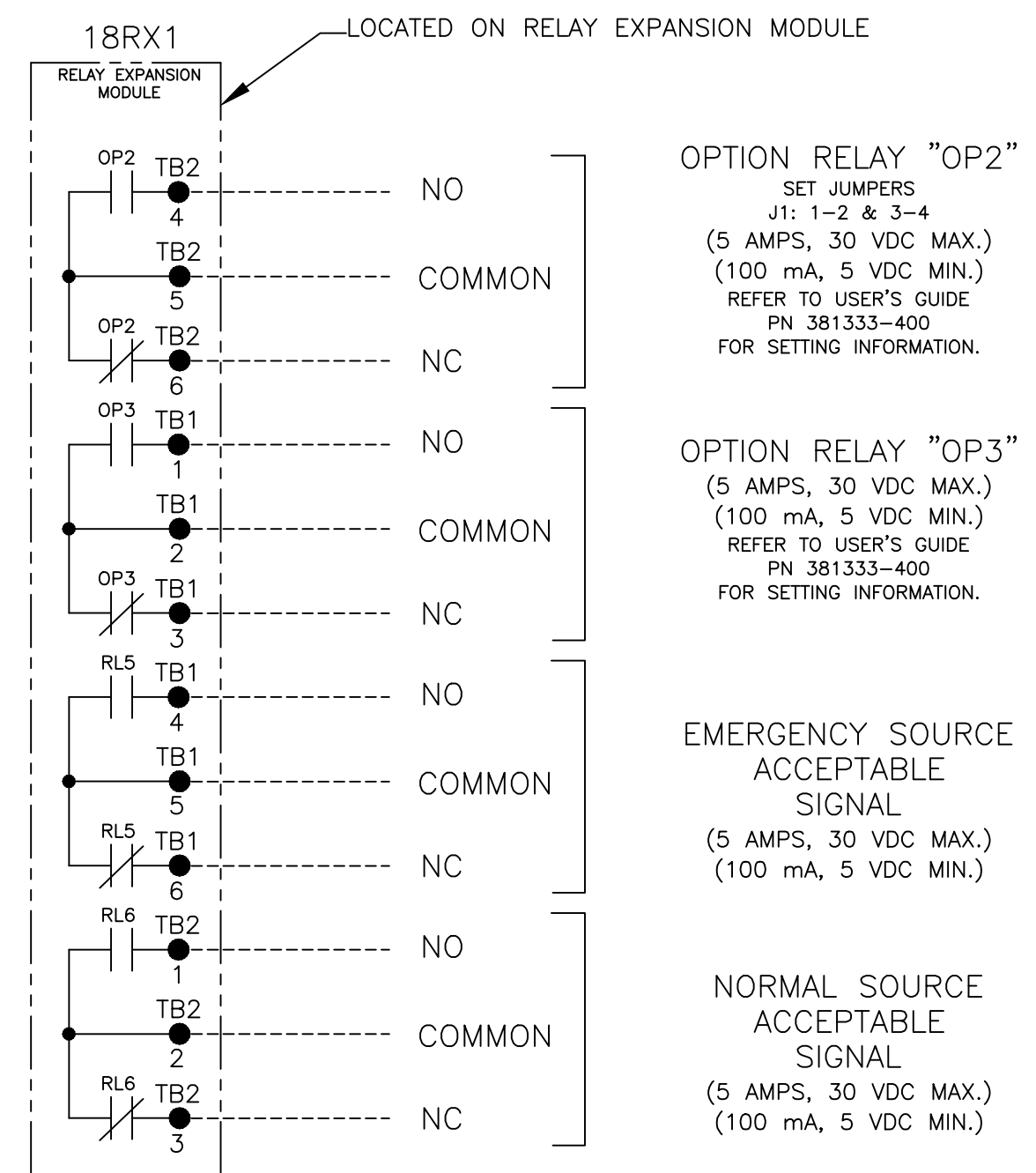

G	278589	TR	BK	05/03/19
	SEE ECN			
F	275211	TR	BK	10/16/18
	SEE ECN			
E	266495	MKA	JPB	04/10/17
	SEE ECN			
D	251210	AJ	MM	10/17/14
	SEE ECN			
C	247770	SDH	SDH	4/14/14
	SEE ECN			
B	246325	AE	BK	01/16/14
	SEE ECN			
A	242580	SDH	SDH	5/30/13
	SEE ECN			
-	242255	SDH	SDH	5/6/13
	ISSUE			

PROJECT NAME:		REV. TO SHEET	ECN NO.	BY	APP.	DATE
WIRING DIAGRAM						
300 SERIES J3ATS/J3NTS, THREE PHASE 600 AMPS "J" FRAME, GROUP G CONTROLS						
DRAWN BY	SDH	DATE	5/6/13	MANUFACTURING TOLERANCES TO BE IN ACCORDANCE WITH ASCO PROCEDURE MP-1-003. FOR PLASTIC PARTS SEE MP-1-005	ASSEM. REF. NO.	COMPUTER GENERATED DRAWING
CHECKED				PROPERTY OF ASCO POWER TECHNOLOGIES. USE PERMITTED FOR OUR WORK ONLY. ALL RIGHTS OF DESIGN OR INVENTION ARE RESERVED.	SCALE	SIZE DS
PROJECT APPROVAL						
FINAL APPROVAL	SDH	DATE	5/6/13			
DWG. NO. 978745		DRAWING G		ECN NO. 278589		SHEET 2 OF 6
ASCO POWER TECHNOLOGIES, L.P. FLORHAM PARK, NEW JERSEY 07932 U.S.A.						

MAIN POWER POLES

TS OPERATOR CIRCUIT

EMERGENCY

NORMAL

LOAD

EMERGENCY

NORMAL

OPTIONAL NEUTRAL TYPES

REFER TO "EXPLANATION OF CATALOG NUMBER CODES" IN CATALOG NUMBER CHART ON SHEET 1.

- SOLID BUS PLATE
- SWITCHING CONTACTS

NOTE:
ATS SHOWN CLOSED ON NORMAL SOURCE.

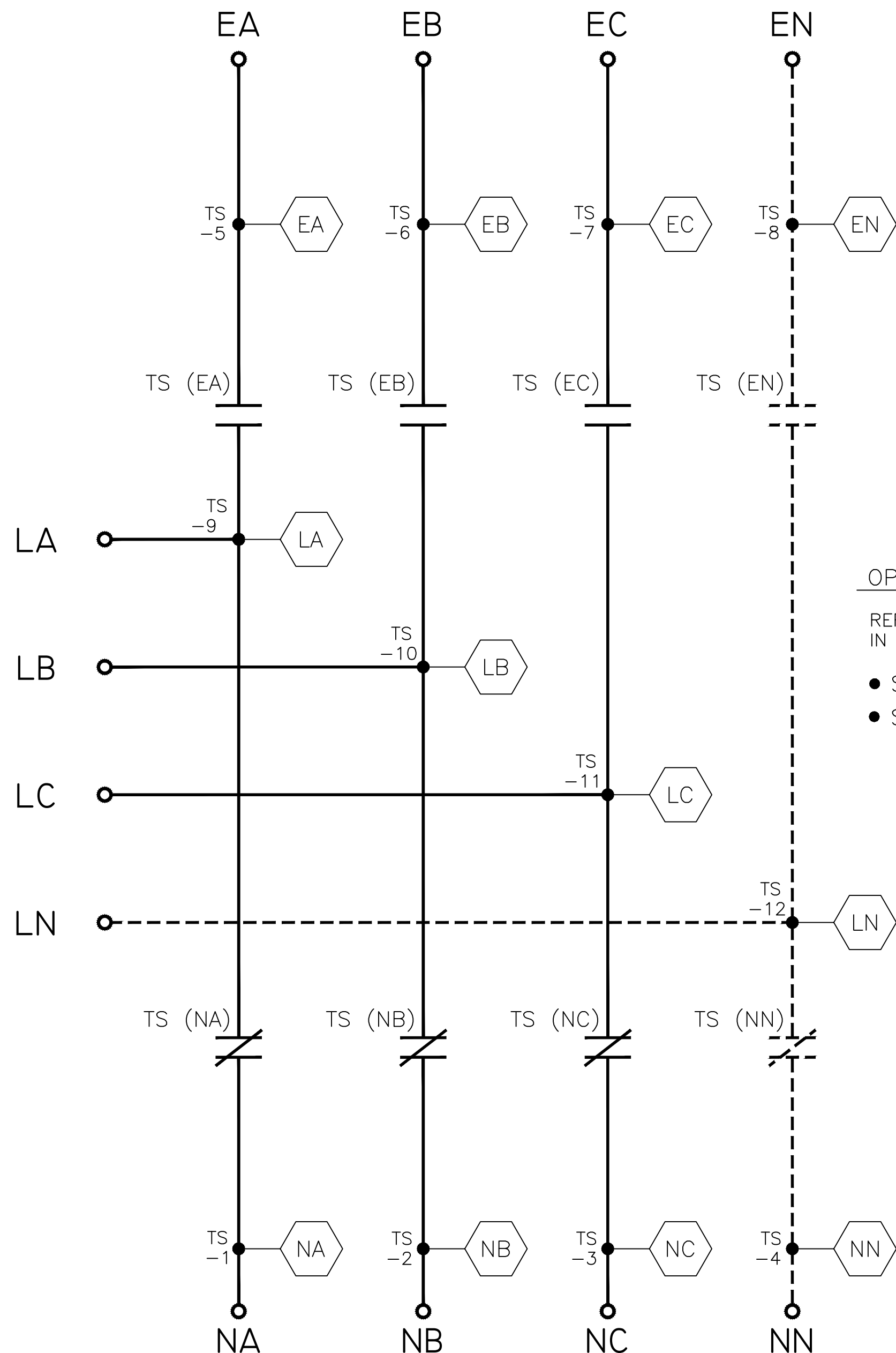
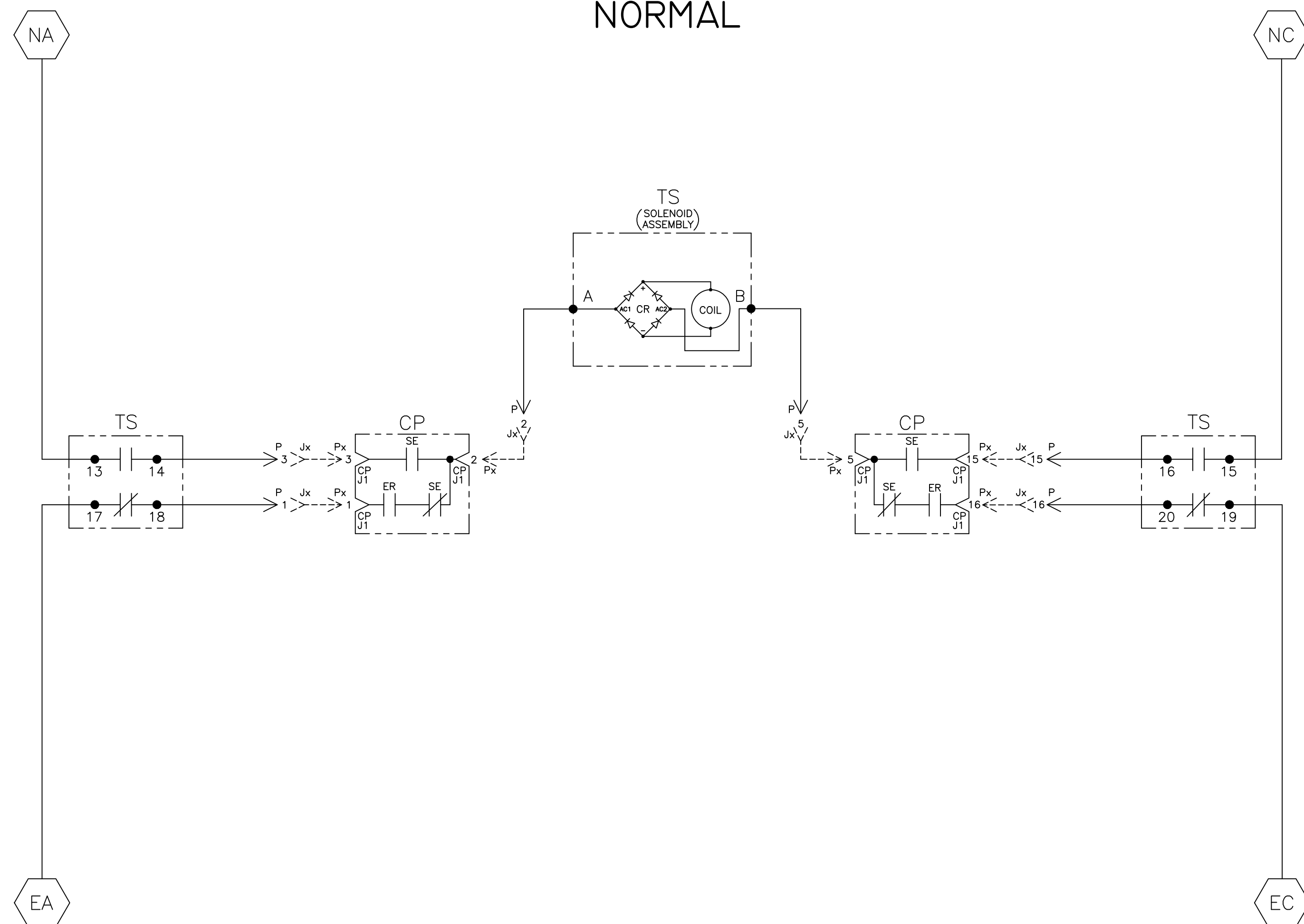

TS	SOLENOID POSITION			
	CLOSED BEFORE NORMAL	BEFORE TDC	BEFORE CLOSED	BEFORE TDC EMERG
13-14				
15-16				
17-18				
19-20				

TDC (TOP DEAD CENTER)
TRANSFER SWITCH TEST & ADJUSTMENT PROCEDURE
SPECIFIES CONTROL CUT-OFF (CONTACT OPENING)
SETTING.

G	278589	TR	BK	05/03/19
F	275211	TR	BK	10/16/18
E	266495	MKA	JPB	04/10/17
D	251210	AJ	MM	10/17/14
C	247770	SDH	SDH	4/14/14
B	246325	AE	BK	01/16/14
A	242580	SDH	SDH	5/30/13
-	242255	SDH	SDH	5/6/13
-	ISSUE			

PROJECT NAME:		REV. TO SHEET	ECN NO.	BY	APP.	DATE
WIRING DIAGRAM						
300 SERIES J3ATS/J3NTS, THREE PHASE 600 AMPS "J" FRAME, GROUP G CONTROLS						
DRAWN BY	SDH	DATE	5/6/13	MANUFACTURING TOLERANCES TO BE IN ACCORDANCE WITH ASCO PROCEDURE MP-1-003. FOR PLASTIC PARTS SEE MP-1-055	ASSEM. REF. NO.	COMPUTER GENERATED DRAWING
CHECKED				PROPERTY OF ASCO POWER TECHNOLOGIES. USE PERMITTED FOR OUR WORK ONLY. ALL RIGHTS OF DESIGN OR INVENTION ARE RESERVED.		SCALE NONE SIZE DS
PROJECT APPROVAL						DWG. NO. 978745
FINAL APPROVAL	SDH	5/6/13		ASCO POWER TECHNOLOGIES, L.P. FLORHAM PARK, NEW JERSEY 07932 U.S.A.		DRAWING G ECN NO. 278589 SHEET 3 OF 6

NORMAL SOURCE CIRCUITS

NORMAL

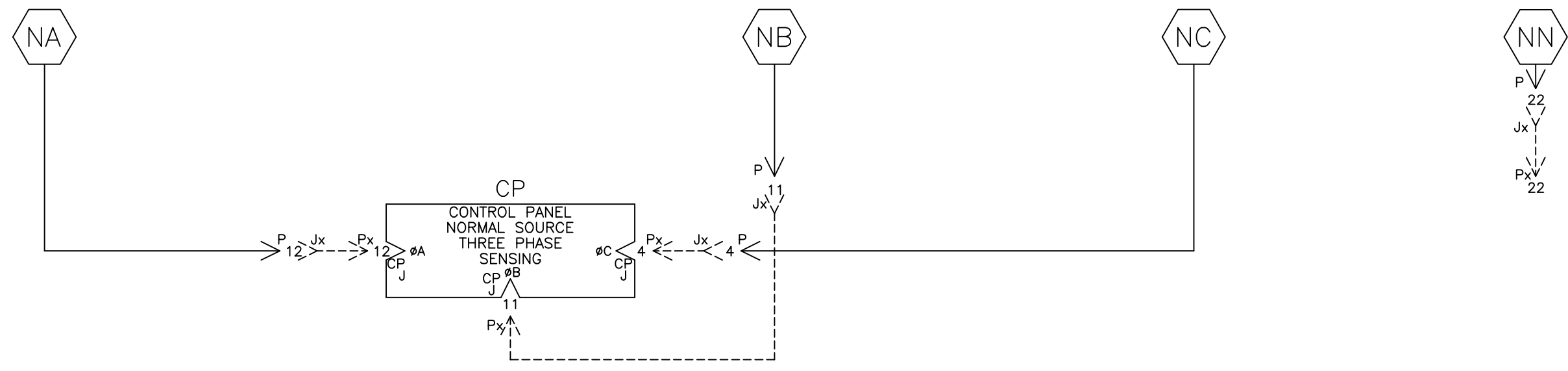

EMERGENCY SOURCE CIRCUITS

EMERGENCY

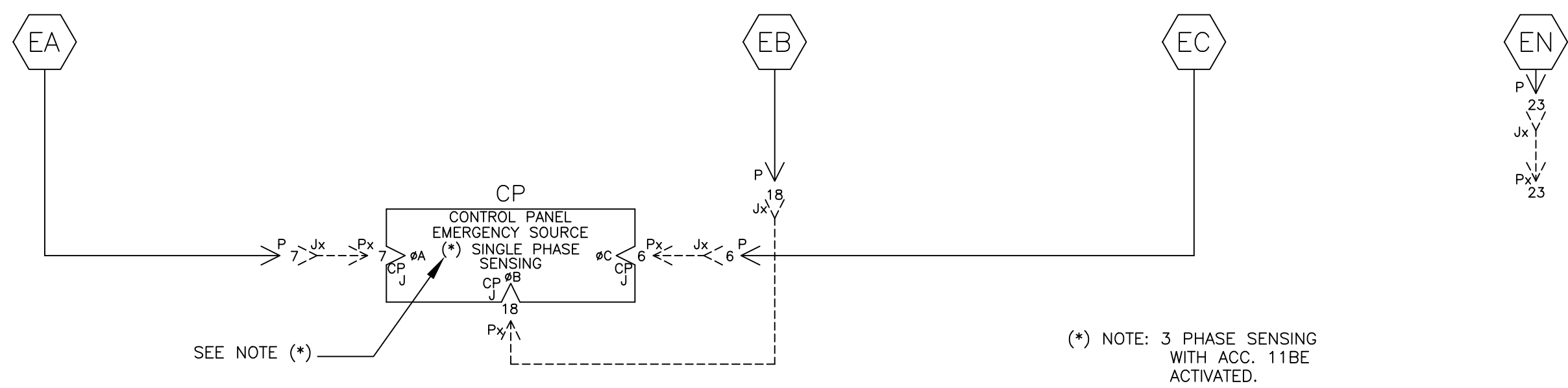

LOAD TERMINAL CIRCUITS

LOAD



CONTROL SIGNALS & INDICATION

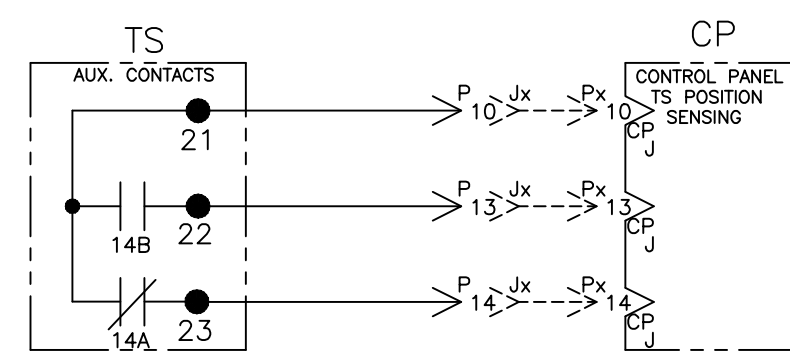

ADDITIONAL CIRCUITS

OPTIONAL ACCESSORY 23GB (LOAD CURRENT METERING)

CURRENT TRANSFORMER RATIO TABLE	
SWITCH RATING	CT RATIO
600A	600:5A

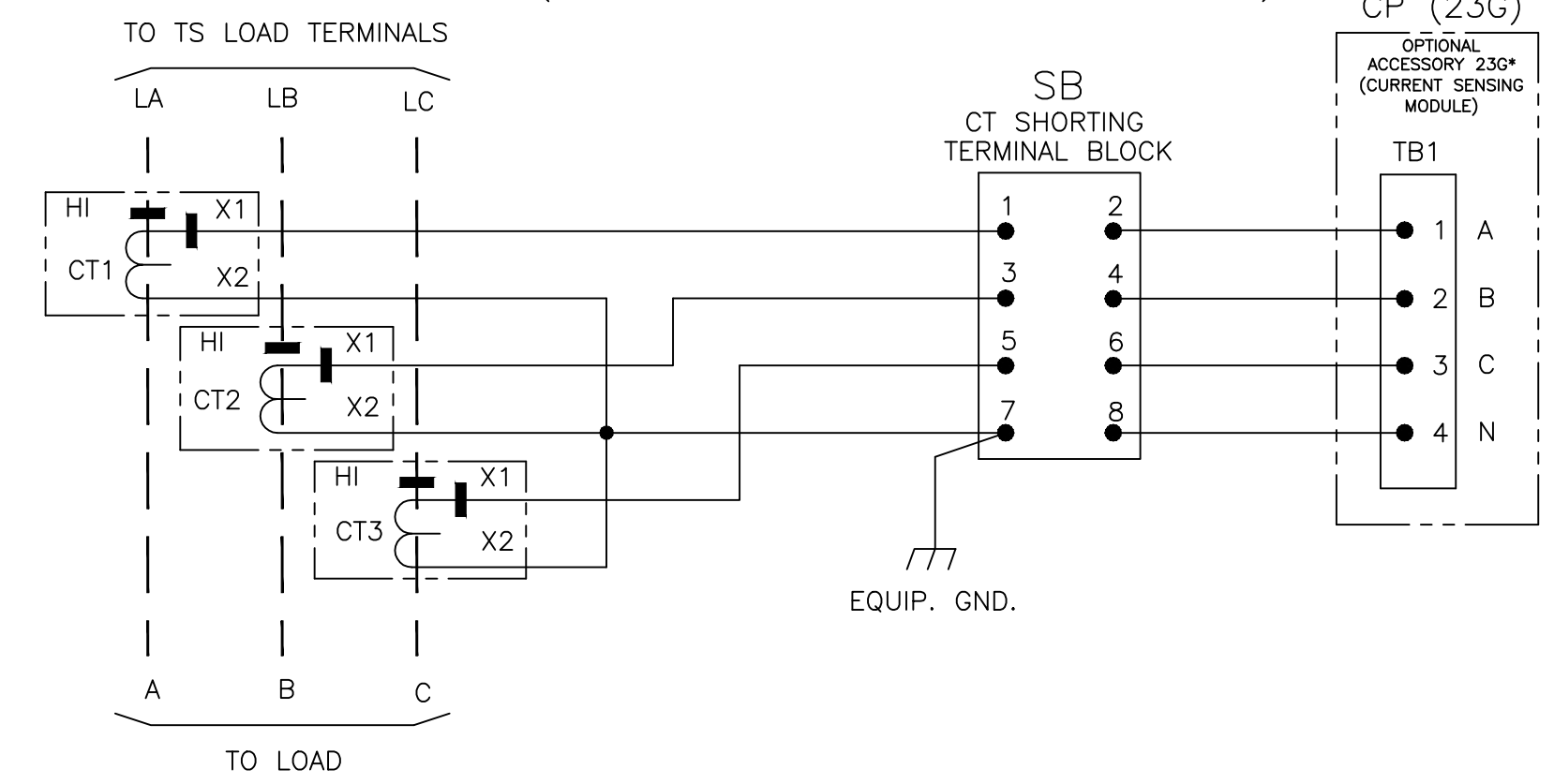

G	278589	TR	BK	05/03/19
	SEE ECN			
F	275211	TR	BK	10/16/18
	SEE ECN			
E	266495	MKA	JPB	04/10/17
	SEE ECN			
D	251210	AJ	MM	10/17/14
	SEE ECN			
C	247770	SDH	SDH	4/14/14
	SEE ECN			
B	246325	AE	BK	01/16/14
	SEE ECN			
A	242580	SDH	SDH	5/30/13
	SEE ECN			
-	242255	SDH	SDH	5/6/13
	ISSUE			

PROJECT NAME:		REV. TO SHEET	ECN NO.	BY	APP.	DATE
WIRING DIAGRAM						
300 SERIES J3ATS/J3NTS, THREE PHASE 600 AMPS "J" FRAME, GROUP G CONTROLS						
DRAWN BY	DATE	MANUFACTURING TOLERANCES TO BE IN ACCORDANCE WITH ASCO PROCEDURE MP-1-003. FOR PLASTIC PARTS SEE MP-1-005.		ASSEM. REF. NO.	COMPUTER GENERATED DRAWING	
CHECKED		PROPERTY OF ASCO POWER TECHNOLOGIES, USE PERMITTED FOR OUR WORK ONLY. ALL RIGHTS OF DESIGN OR INVENTION ARE RESERVED.			SCALE	SIZE DS
PROJECT APPROVAL					DWG. NO. 978745	
FINAL APPROVAL	SDH 5/16/13	ASCO® ASCO POWER TECHNOLOGIES, L.P. FLORHAM PARK, NEW JERSEY 07932 U.S.A.		DRAWING G	ECN NO. 278589	SHEET 4 OF 6

PHYSICAL DIAGRAM

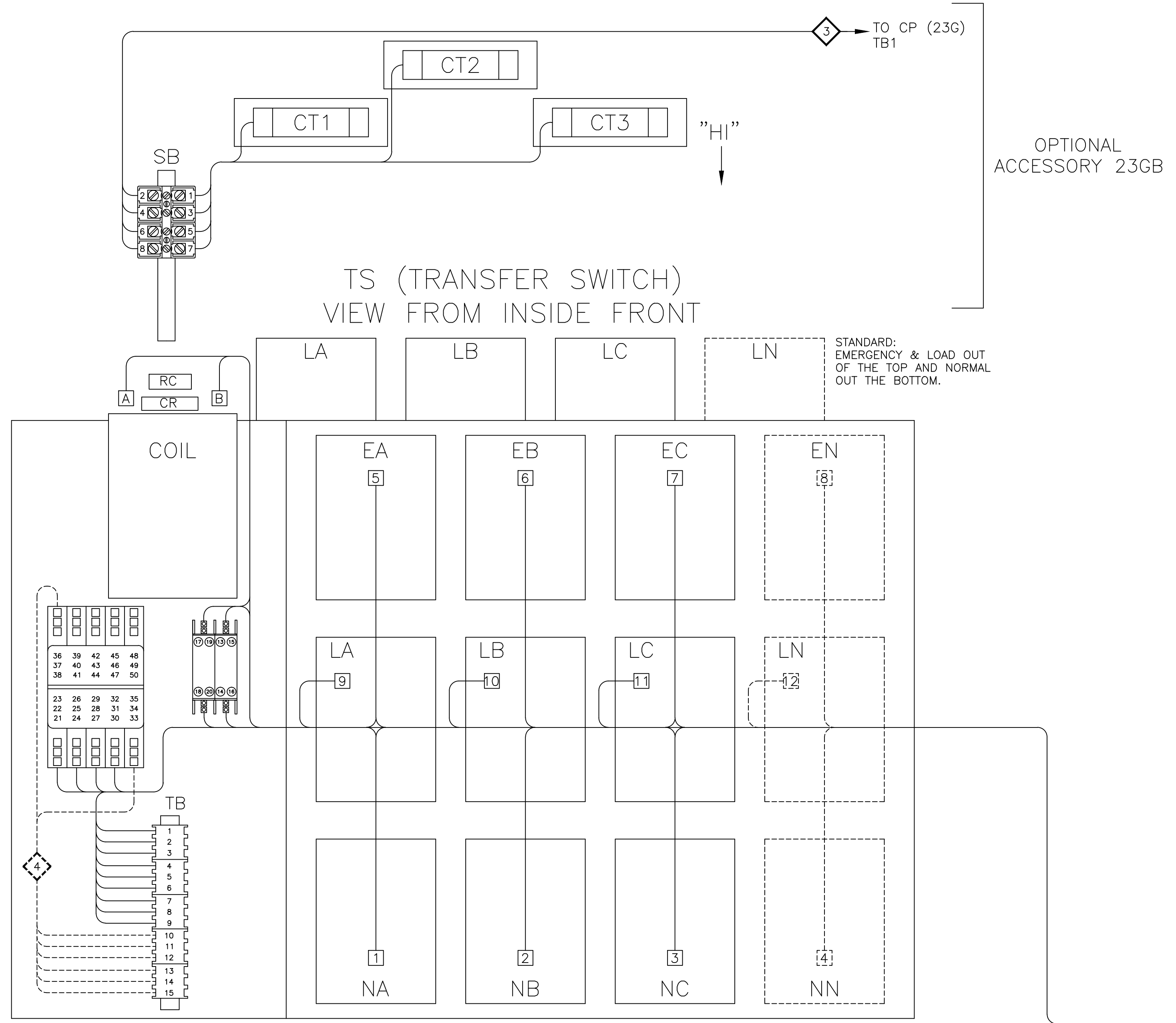

OPTIONAL ACCESSORY 23GB

STANDARD:
EMERGENCY & LOAD OUT OF THE TOP AND NORMAL OUT THE BOTTOM.

DOOR (INSIDE)

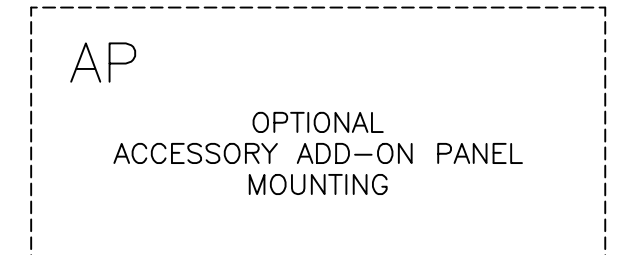
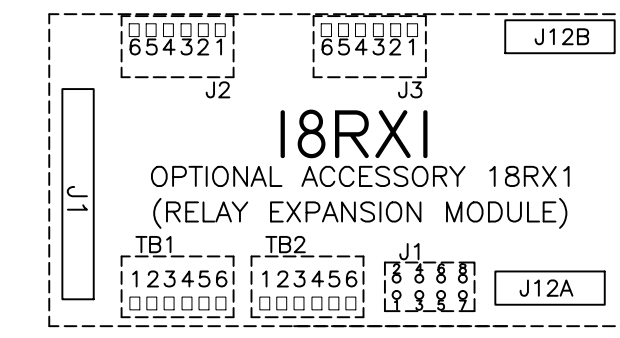
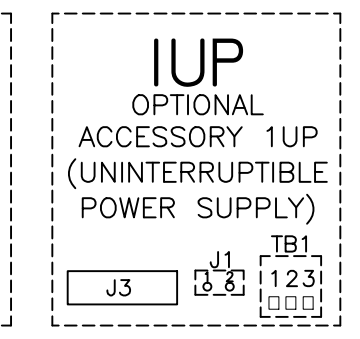
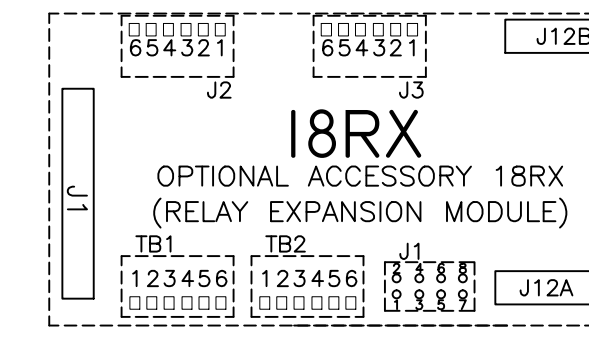
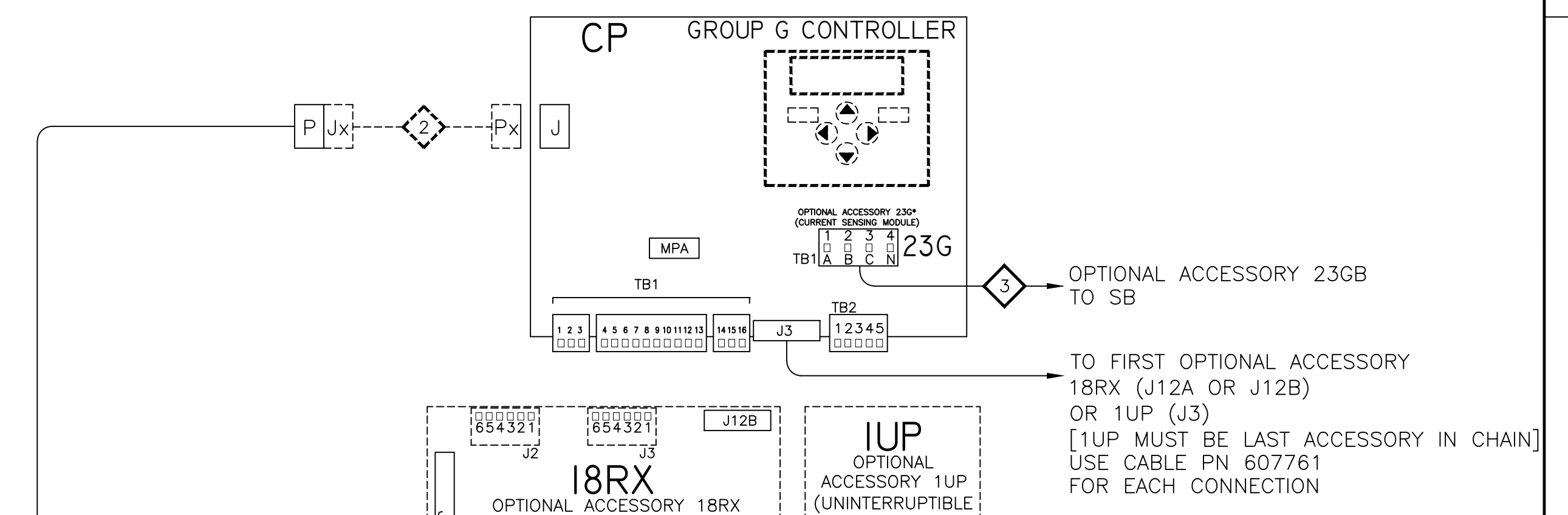
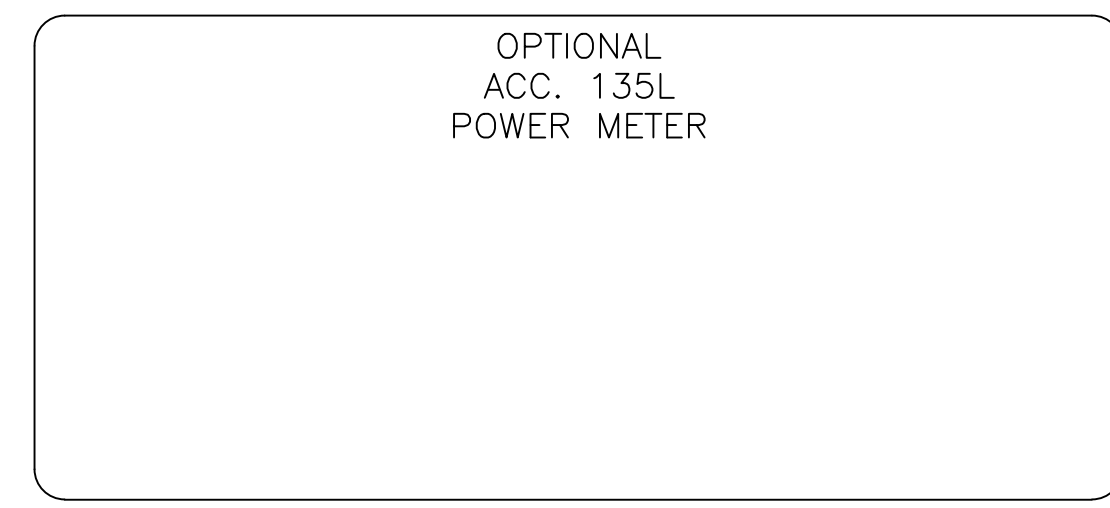

G	278589	TR	BK	05/03/19
F	275211	TR	BK	10/16/18
E	266495	MKA	JPB	04/10/17
D	251210	AJ	MM	10/17/14
C	247770	SDH	SDH	4/14/14
B	246325	AE	BK	01/16/14
A	242580	SDH	SDH	5/30/13
-	242255	SDH	SDH	5/6/13
-	ISSUE			

PROJECT NAME:		REV. TO SHEET	ECN NO.	BY	APP.	DATE
WIRING DIAGRAM						
300 SERIES J3ATS/J3NTS, THREE PHASE 600 AMPS "J" FRAME, GROUP G CONTROLS						
DRAWN BY	SDH	DATE	5/16/13	MANUFACTURING TOLERANCES TO BE IN ACCORDANCE WITH ASCO PROCEDURE MP-1-003. FOR PLASTIC PARTS SEE MP-1-055.	ASSEM. REF. NO.	SCALE
CHECKED				PROPERTY OF ASCO POWER TECHNOLOGIES, USE PERMITTED FOR OUR WORK ONLY. ALL RIGHTS OF DESIGN OR INVENTION ARE RESERVED.		SIZE DS
PROJECT APPROVAL						DWG. NO. 978745
FINAL APPROVAL	SDH	5/16/13				DRIVING G ECN NO. 278589 SHEET 5 OF 6

DOOR HINGE

BONDING STRAP
PN 098323-019

Limited Warranty

Series 150, 200, 300 and 4000 Power Transfer Switches

This Warranty is given ONLY to purchasers who buy for commercial or industrial use in the ordinary course of each purchaser's business.

General

ASCO Power Technologies, LP products and systems are in our opinion the finest available. We take pride in our products and are pleased that you have chosen them. Under certain circumstances we offer with our products the following Limited Guardian Warranty Against Defects in Material and Workmanship.

Please read your Guardian Warranty carefully. This Warranty sets forth our responsibilities in the unlikely event of defect and tells you how to obtain performance under this Warranty.

Limited Warranty Against Defects in Material and Workmanship:

Product Description	Series	Catalog Code
Automatic Transfer Switch	150, 200	1ATS, 2ATS
	300	3ATS, 3ADTS
	4000	4ATS, 4ADTS, 4ACTS
Non-Automatic Transfer Switch (Electrically Operated)	300	3NTS, 3NDTS
ASCO Lighting Control Panels	4000	4NTS, 4NDTS, 4NCTS
Manual Transfer Switch	300	3MTS, 3MTQ, 3MUQ, 3MPQ, 3MGQ, 3MGDQ, 3MTDQ
Service Entrance Transfer Switch (SEATS)	300	3AUS, 3ADUS, 3APS, 3ARS, 3MUS
Power Transfer Load Center (PTLC)	300	300L
Quick Connect Panels	300	3QCN, 3QCU, 3QCD
Electrically Operated Bypass Switch	4000	4ATE, 4NTE, 4ADTE, 4NDTE

Limited Warranty

ASCO warrants that the ATS will be free from defects in material and workmanship and will conform to ASCO's standard specifications for the ATS for a period of twenty four (24) months from date of product shipment from ASCO (the "Warranty Period"). This Limited Warranty does not extend to subsequent owners of the structure during the Warranty period.

Terms of Warranty

The foregoing Limited Warranty is conditioned upon user's compliance with the following:

1. The ASCO Power Transfer Switch is installed in accordance with ASCO specifications and state and local codes and standards by an electrician licensed in the state of installation.
2. The ASCO Power Transfer Switch is maintained in accordance with ASCO instructions and used under normal conditions for the purposes intended by ASCO.

All warranty field-related repairs, replacements or adjustments must be made by ASCO Services Inc. or its duly authorized representative.

Optional Available Extended Warranty

Optional extended warranty coverage may be purchased from ASCO for a specified fee at the time of the original sale. If purchased, Warranty period shall be extended up to an additional thirty - six (36) months beyond the standard twenty - four (24) months to provide up to five (5) year coverage applicable to the above referenced products, except for 3AUS, 3APS, and 3ARS products where the warranty period for the circuit breaker shall be limited to 24 months from date of shipment from ASCO. The length of optional extended coverage shall be reflected on the ASCO invoice and/or order acknowledgement document.

**Warranty Extends
To First Purchaser
for Use,
Non-Transferable**

This Warranty is extended to the first person, firm, association, or corporation for whom the ASCO product specified herein is originally installed for use (the "user") in the fifty United States or Canada. This Warranty is not transferable or assignable without the prior written permission of ASCO.

**Assignment of
Warranties**

ASCO assigns to user any warranties which are made by manufacturers and suppliers of components of, or accessories to, the ASCO product and which are assignable, but ASCO makes no representations as to the effectiveness or extent of such warranties, assumes no responsibility for any matters which may be warranted by such manufacturers or suppliers and extends no coverage under this Warranty to such components or accessories.

**Drawings,
Descriptions**

ASCO warrants for the period and on the terms of the Warranty set forth herein that the ASCO product will conform to the descriptions contained in the certified drawings, if any, applicable thereto, to ASCO's final invoices, and to applicable ASCO product brochures and manuals current as of the date of product shipment ("descriptions"). ASCO does not control the use of any ASCO product. Accordingly, it is understood that the descriptions are not Warranties of performance and not Warranties of fitness for a particular purpose.

**Warranty Claims
Procedure**

Within a reasonable time, but in no case to exceed thirty (30) days, after user's discovery of a defect, user shall contact ascopowerwarranty@ascopower.com. Subject to the limitations specified herein, an ASCO Services field service representative will repair the non-conforming ASCO product warranted hereunder, without charge for parts, labor, or travel expenses. Warranty coverage will apply only after ASCO's inspection discloses the claimed defect and shows no signs of treatment or use that would void the coverage of this Warranty. All defective products and component parts replaced under this Warranty become the property of ASCO.

**Warranty
Performance of
Component
Manufacturers**

It is ASCO's practice, consistent with its desire to remedy Warranty defects in the most prompt and effective manner possible, to cooperate with and utilize the services of component manufacturers and their authorized representatives in the performance of work to correct defects in the product components. Accordingly, ASCO may utilize third parties in the performance of Warranty work, including repair or replacement hereunder, where, in ASCO's opinion, such work can be performed in less time, with less expense, or in closer proximity to the ASCO product.

**Items Not Covered
By Warranty**

This Warranty does not cover damage or defect caused by misuse, improper application, wrong or inadequate electrical current or connection, negligence, inappropriate on site operating conditions, repair by non-ASCO designated personnel, accident in transit, tampering, alterations, a change in location or operating use, exposure to the elements, water, or other corrosive liquids or gases, acts of God, theft or installation contrary to ASCO's recommendations or specifications, or in any event if the ASCO serial number has been altered, defaced, or removed.

This Warranty does not cover shipping costs, installation costs, external circuit breaker resetting or maintenance or service items and further, except as may be provided herein, does not include labor costs or transportation charges arising from the replacement of the ASCO product or any part thereof or charges to remove or reinstall same at any premises of user.

Repair or replacement of a defective product or part thereof does not extend the original Warranty period.

The products listed in this Warranty are not for use in the control area or any reactor connected or safety applications or within the containment area of a nuclear facility or for integration into medical devices.

Limitations

This Warranty is in lieu of and excludes all other Warranties, express or implied, including merchantability and fitness for a particular purpose.

User's sole and exclusive remedy is repair or replacement of the ASCO product as set forth herein.

If user's remedy is deemed to fail of its essential purpose by a court of competent jurisdiction, ASCO's responsibility for property loss or damage shall not exceed the net product purchase price.

In no event shall ASCO assume any liability for indirect, special, incidental, consequential or exemplary damages of any kind whatsoever, including without limitation lost profits, business interruption or loss of data, whether any claim is based upon theories of contract, negligence, strict liability, tort, or otherwise.

Miscellaneous

No salesperson, employee, or agent of ASCO is authorized to add to or vary the terms of this Warranty. Warranty terms may be modified, if at all, only in writing signed by an ASCO officer.

ASCO obligations under this Warranty are conditioned upon ASCO timely receipt of full payment of the product purchase price and any other amounts due. ASCO reserves the right to supplement or change the terms of this Warranty in any subsequent warranty offering to user or others.

In the event that any provision of this Warranty should be or becomes invalid and/or unenforceable during the Warranty period, the remaining terms and provisions shall continue in full force and effect.

This Warranty shall be governed by, and construed under, the laws of the State of New Jersey, without reference to the conflict of laws principles thereof.

This Warranty represents the entire agreement between ASCO and user with respect to the subject matter herein and supersedes all prior or contemporaneous oral or written communications, representations, understandings, or agreements relating to this subject.

EQUIPMENT STORAGE REQUIREMENTS

Equipment provided by Schneider-Electric and/or ASCO Power Technologies that is stored for a short-term duration (i.e., days to weeks) or long-term duration (i.e., months to years), must be kept in a cool, dry, temperature-controlled environment. Storage of equipment in open warehouses, locations without proper temperature and humidity control, and/or outdoor storage is not acceptable without the utilization of heating elements, thermostats, humidistats, and protection from weather and dirt. Failure to comply may result in moisture ingress and/or condensation to form resulting in rusting and or corrosion, component and/or equipment failure and replacement, and/or nullification of any manufacturer warranty.

For **General Instructions for Proper Handling, Installation, Operation, and Maintenance of Deadfront Distribution Switchboards Rated 600 Volts or Less**, refer to [ANSI NEMA PB 2.1-2013](#)

Copies of the following documents should be included on the submittals, depending on the units that are on the proposal:

For ASCO Power Technology's **Switchgear and Switchboards**, refer to Instruction Bulletin **381333-393**.

For Schneider-Electric/Square D's **Power Zone 4 (PZ4) Switchgear**, refer to Instruction Bulletin **80298-002-09**.

For Schneider-Electric/Square D's **Power Zone 4 (PZ4) NEMA 3R Walk-In Switchgear**, refer to Instruction Bulletin **80298-156-02**.

For Schneider-Electric/Square D's **Quality, Efficient, Delivery" (QED2) Switchboard**, refer to Instruction Bulletin **80043-055-14**.

For Schneider-Electric/Square D's **Masterclad Metal-Clad Indoor Switchgear**, refer to Instruction Bulletin **6055-30**.



Flexible Power Transfer Solutions for Commercial & Industrial Applications

ASCO Power
Technologies™

ASCO SERIES 300
Power Transfer Switches



ascopower.com

Life Is 

Schneider
Electric

ASCO SERIES 300 Automatic Transfer Switches

Power outages impact small and large facilities alike. ASCO SERIES 300 Automatic Transfer Switches offer rugged design and reliable performance to small and mid-size commercial and industrial facilities in packaged solutions that are easy to select, procure, install, and operate.

Every SERIES 300 generator transfer switch is engineered with ASCO's reliability expertise in a package that makes backup power accessible for small and mid-size facilities. Leveraging knowledge derived from a century of critical power transfer experience, each SERIES 300 is backed by the same ASCO technical support and service that solves the most demanding critical power challenges facing facilities today.

Product Details

[Transfer Switch Overview](#)



ASCO's SERIES 300 lineup offers flexible backup power solutions for businesses of every size.

SERIES 300 Automatic Transfer Switches

Designed to Fit Anywhere

The ASCO SERIES 300 product line provides the most compact design of generator power transfer switches in the industry.

Available to mount on walls or floors, all models through 2000 amperes are designed to be completely front-accessible. This permits installation flush against walls while allowing installation of cabling and connections from the front of the switch. Cable entrance plates are standard on 1600 and 2000 amperes units; these allow use of optional side-mounted pull boxes for additional cable bending space.

- 30 through 3000 amperes in compact designs
- Up to 600 VAC, single or three phase
- Listed to UL 1008 - Standard for Safety - Transfer Switch Equipment
- True double-throw operation: The single solenoid design is inherently interlocked to prevent simultaneous connections of two power sources.
- Will not transfer to a dead source - single solenoid operator derives power from the destination source
- Easy-to-navigate 128x64 graphical LCD display with keypad provides LED indicators for switch position, source availability, not-in-auto mode, and alert conditions.
- Integrated, multilingual, user interface for configuration and monitoring
- Available Delayed Transition operation
- Optional Relay Expansion Module with extra relays for accessory outputs
- Soft keys for test function and time delay bypass
- Emergency source failure alert indication
- Optional Historical Event Log
- Displays statistical ATS monitoring information
- Built-in diagnostic functions
- Password protection to prevent unauthorized actions
- Adjustable delay feature prevents nuisance transfer due to momentary utility power outages and generator dips
- Auxiliary contacts signal position of main contacts - two for normal and two for emergency position
- Standard solid neutral terminals
- Restriction of Hazardous Substances (RoHS) compliant controller
- Standard 2 year warranty. Optional 1, 2, and 3 year extensions

Power Knowledge

[Basic Automatic Transfer Switch Functions](#)



SERIES 300 Power Transfer Switch rated 200 amps

SERIES 300 Automatic Switching Solutions

Automatic and Non-Automatic Transfer Switching

ASCO Transfer Switches are available in both automatic and non-automatic types. Both are electrically operated. For automatic transfer switches, the controller initiates transfer between power sources. For non-automatic transfer switches, a user initiates transfer using local or remote controls.

SERIES 300 non-automatic transfer switches offer the following features:

- Models range from 30 through 3000 amperes, up to 600V
- Source acceptability lights inform operator when sources are available to accept load
- Controller prevents inadvertent operation under low voltage conditions
- Standard in-phase monitor for transferring motor loads between live sources

Power Knowledge

[Non-Automatic and Manual Transfer Switches for Backup Power Applications](#)



Open Transition Transfer Switching

ASCO Transfer Switches are available with a standard, 2-position, open transition models that reliably transfer loads in less than 100 milliseconds. Open transition switches are suitable for a wide range of applications.

- 30 to 3000 amps
- Single-operator switching mechanism prevents simultaneous connection of both sources
- Available In-Phase Monitor can be activated for transferring motor loads

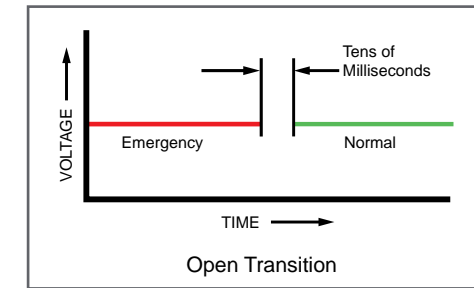

Delayed Transition Transfer Switching

ASCO Delayed Transition Transfer Switches transfer loads between power sources using a timed load disconnect position with an adjustable delay.

- 150 through 3000 amps
- Reliable, field-proven, dual-solenoid operating mechanism
- Mechanical interlocks to prevent simultaneous connection of both power sources
- Adjustable delay for load disconnect - 0 to 5 minutes
- Non-automatic models available in manual operation configuration
- Automatic models available with load shed feature

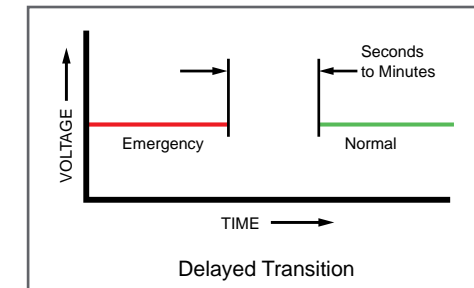

SERIES 300 Group G Controller

The SERIES 300 Group G Controller is reliable and field-proven. It provides all of the voltage, frequency, control, timing, and diagnostic functions required for most emergency and standby power applications.

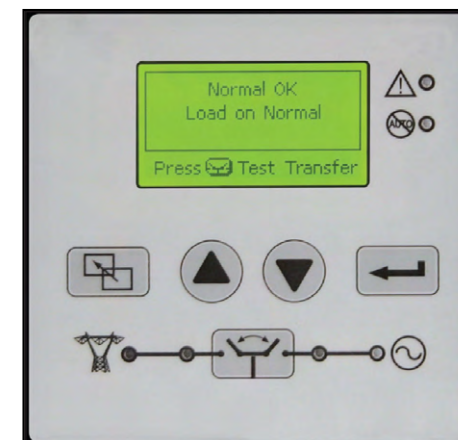

- Touch pad programming
- Displays active timers
- On-board diagnostics
- Password protection
- Voltage and frequency sensing
- Status and control functions

Power Knowledge

[Transition Mode Basics](#)

[Transferring Motor Loads between Power Sources](#)

[Transferring Loads with Zero Power Interruption](#)

Product Details

[Group G Controller](#)

Transfer Switch Communications and Metering

Options to Customize Functionality and Increase Value

Product Details

[5300 SERIES Annunciators](#)

Remote Annunciation

Monitor Power Equipment Status from Anywhere

Monitoring and control transfer switches from across the room, building, or from Internet.

5310 – LED annunciator – Single ATS

5350 – LED annunciator – up to 8 ATSs



Product Details

[5140 Connectivity Module](#)

Communication

Turn Transfer Switches into Power Information Portals

5140 Connectivity Module – Makes status and power information from a single switch available to via ModBUS, SNMP, and web pages.



Metering

Transfer Switches are the Perfect Place to Monitor Power Flow, Power Conditions, and Power Events

5210 Power Meter – Provides deeper insight into circuit status and conditions.

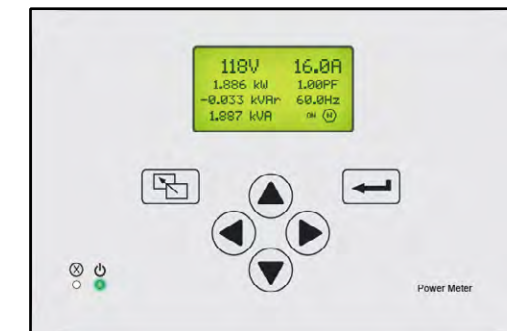

Product Details

[5210 Power Meter](#)

SERIES 300 Optional Accessories

Communications

11BE	Feature Bundle. Programmable engine exerciser with seven independent routines run the generator with or without loads, on a daily, weekly, bi-weekly, or monthly basis. Controlled from the user interface keypad. <ul style="list-style-type: none"> Event log display shows the event number, time and date, type and reason (if applicable). Stores up to 300 events RS485 Communication Port enabled common alarm output contact On three-phase systems, Accessory 11BE enables line-to-line voltage imbalance sensing and three-phase sensing capabilities for the Emergency power source as well as the Phase Rotation checking for both power sources.
18RX	Relay Expansion Module provides accessory relays and includes one Form C contact for normal source availability (18G), and one Form C contact for emergency source availability (18B) (contact rating 5 amperes @ 30 VDC or @ 125 VAC resistive) (100 ma, 4 VDC min) Additional output relay is provided the default is to indicate a common alarm.
72EE	Connectivity module provides remote monitoring and control capabilities and includes accessory 11BE feature bundle

Environment and Power

44A	Strip heater with thermostat for cold environment to prevent internal condensation and icing. External 120-volt AC power source required.
44G	Strip heater with thermostat, wired to load terminals on 208-240, 360-380, 460-480, 550-600 volt models. Contains wiring harnesses for all transfer switch sizes.
1UP	UPS back up power runs controller and LCD display for 30 seconds without AC power

Extension Harness

37B	Six-foot extension harness for open type units to accommodate customer mounting of controls and switch
37C	Nine-foot extension harness for open type units to accommodate customer mounting of controls and switch

Indicators

62W	Audible alarm with silencing feature to signal transfers to emergency. (For D-frame models, may require oversize enclosure depending on accessory combination).
------------	---

Customer Control Circuits

30A	Load-shed circuit initiated by opening of a customer-supplied contact (Open Transition model only)
30B	Load-shed circuit initiated by removal of customer-supplied control voltage (Open Transition model only)
30AA	Load-shed circuit initiated by opening of a customer-supplied contact (Delayed Transition model only)
30BA	Load-shed circuit initiated by removal of customer-supplied control voltage (Delayed Transition model only)

Surge Protection

73	Surge suppressor rated 65 kA
-----------	------------------------------

Metering

23GA, 23GB	Load Current Metering card measures either single or three-phase load current. Not available with Power Meter option 135L. Use 23GA for Single-Phase, 23GB for Three-Phase.
135L	Power Meter on load side (includes shorting block and current transformers). Not available with Load Current Metering options 23GA or 23GB.

Field Conversion Kits

Kit No.	Description
935147	Advanced Function Bundle Retrofit Kit (11BE) - See above accessory 11BE description for details.
935148	REX Module with Source Availability Contacts (Acc. 18RX)
935149	UPS to allow controller to run for 30 seconds minimum without AC Power (Acc. 1UP)
935150	1/3 Phase load current sensing card only (Acc. 23GA/GB)
K613127-001	Strip Heater (125 watt) 120 volt (Acc. 44A)
K613127-002	Strip Heater (125 watt) 208-480 volt (Acc. 44G)
948551	Quad-Ethernet Module (Acc. 72EE)
K609027	Cable Pull Box (1600-2000 amperes)

Withstand and Close-on Ratings

Withstand and Close-on Ratings for all 7000 SERIES Power Transfer Switches, including 0.5 second (30-cycle) designs.

Frame	Switch Rating (Amps)		Current Limiting Fuses				Specific Breaker			Time Based			Short Time Ratings ² (sec)												
	Transfer Switches	Bypass Switches	480V Max.	600V Max.	Max Size, A	Class	240V Max.	480V Max.	600V Max.	Time (sec)	240V Max.	480V Max.	600V Max.	480V Max.				600V Max.							
														.13	.2	.3	.5	.1	.13	.3	.5				
D	30	-	100kA	-	300	J	22kA	25kA	10kA	0.025	10kA	10kA	10kA	-	-	-	-	-	-	-	-	-	-	-	
D	70, 100	-	200kA	35kA	200	RK1	150kA	85kA	25kA	0.025	10kA	10kA	10kA	-	-	-	-	-	-	-	-	-	-	-	
D	150	-	200kA	35kA	200	RK1	150kA	85kA	25kA	0.025	10kA	10kA	10kA	-	-	-	-	-	-	-	-	-	-	-	
D	200	-	200kA	35kA	200	J	200kA	85kA	14kA	0.025	10kA	10kA	10kA	-	-	-	-	-	-	-	-	-	-	-	
D	230	-	100kA	-	300	J	200kA	85kA	14kA	0.025	10kA	10kA	-	-	-	-	-	-	-	-	-	-	-	-	
E	260, 400	-	200kA	-	600	J	65kA	42kA	22kA	0.05	35kA	35kA	22kA	-	-	-	-	-	-	-	-	-	-	-	
J	150, 200, 230, 260	150, 200, 230, 260	200kA	200kA	600	J	200kA	200kA	100kA	0.05	65kA	42kA ⁵	35kA	7.5kA	-	-	-	-	-	-	-	-	-	-	-
J	400	400	200kA	200kA	600	J	200kA	200kA	100kA	0.05	65kA	42kA ⁵	35kA	7.5kA	-	-	-	-	-	-	-	-	-	-	
J	600	600	200kA	200kA	800	L	200kA	200kA	100kA	0.05	65kA	42kA ⁵	35kA	7.5kA ⁹	-	-	-	-	-	-	-	-	-	-	
H ⁸	600	600	200kA	200kA	1600	L	65kA	150kA ⁶	65kA	0.05	50kA	50kA	50kA	36kA	-	36kA	-	-	-	-	-	-	-	-	
P ⁸	600	600	200kA	200kA	1600	L	65kA	150kA ⁶	65kA	0.05	50kA	50kA	50kA	36kA	30kA	36kA	-	-	-	-	-	-	-	-	
P ⁸	800	800 - 1200	200kA	200kA	1600	L	65kA	150kA ⁶	65kA	0.05	50kA	50kA	50kA	36kA	30kA	36kA	-	-	-	-	-	-	-	-	
H	800 - 1200	800 - 1200	200kA	200kA	1600 ⁴	L	65kA	150kA	65kA	0.05	50kA	50kA	50kA	36kA	-	36kA	-	-	-	-	-	-	-	-	
Q ⁸	600-1600	600-1600	200kA	200kA	2000	L	65kA	65kA	65kA	0.05	65kA	65kA	65kA	50kA	-	50kA	-	-	-	-	-	-	-	-	
S ⁸	800 - 1200	800 - 1200	200kA	200kA	2500	L	100kA	100kA	65kA	0.05	100kA	100kA	65kA	65kA	-	65kA	-	-	-	-	-	-	-	-	
G ⁸	1000 - 1200	1000 - 1200	200kA	200kA	2000	L	85kA	85kA	85kA	0.05	85kA	85kA	85kA	42kA	36kA	-	-	-	-	-	-	-	-	-	
G	1600 - 2000 (Front Connected TS Only)	1600 - 2000	200kA	200kA	2500	L	85kA	85kA	85kA	0.05	85kA	85kA	85kA	42kA	36kA	-	-	-	-	-	-	-	-	-	
G ⁸	1600 - 2000	1600 - 2000	200kA	200kA	3000	L	200kA	200kA	100kA	0.05	100kA	100kA	100kA	42kA	36kA	42kA	-	-	-	-	-	-	-	-	
S ⁸	1600 - 2000	1600 - 2000	200kA	200kA	2500	L	100kA	100kA	85kA	0.05	100kA	100kA	85kA	85kA	65kA	85kA	65kA	85kA	65kA	85kA	65kA	85kA	65kA	85kA	
G	2600 - 3000	2600 - 3000	200kA	200kA	4000	L	125kA ⁶	125kA ⁶	100kA	0.05	100kA	100kA	100kA	42kA	36kA	42kA	-	-	-	-	-	-	-	-	
G ⁸	3200	-	200kA	-	4000	L	100kA	100kA	-	0.05	100kA	100kA	-	-	-	-	-	-	-	-	-	-	-	-	
G	4000	4000	200kA	200kA	5000	L	100kA	100kA	100kA	0.05	100kA	100kA	100kA	85kA	65kA	65kA	-	-	-	-	-	-	-	-	
U ⁸	2600 - 4000	2600 - 4000	200kA	200kA	5000	L	125kA	125kA	125kA	0.05	125kA	125kA	125kA	100kA	-	100kA	-	-	-	-	-	-	-	-	

Notes:

- All WCR values indicated are tested in accordance with the requirements of UL 1008, 7th Edition. See ASCO Pub. 1128 for more WCR information
- Application requirements may permit higher WCR for certain switch sizes.
- Short Time ratings are provided for applications involving circuit breakers that utilize trip delay settings for system selective coordination
- Max fuse rating is 1200A on front connected H frame switches
- Switches utilizing overlapping neutral (code "C") have 35kA, 0.050 Sec time based rating at 480V Max
- Rating shown is for Bypass switches only, Transfer Switch rating is 100kA for the G frame and 65kA max for the H and P frames. See ASCO Pub. 1128.
- See ASCO for Service Entrance Switch ratings
- These frames are only available on the 7000 Series product
- Short Time Rating applies to 600A Bypass switch only, the 600A Transfer Switch does not have a Short Time Rating

All units are RMS Symmetrical Amperes.

All Withstand and Close-on Rating (WCR) values are established by testing in accordance with UL 1008. For the latest ratings, including transfer switch ratings when used with specific circuit breakers, see **ASCO Publication 1128** for more WCR information.

Application characteristics may permit higher WCRs for certain switch sizes. Contact ASCO Power Technologies for more information.

Power Knowledge

 [UL 1008 Transfer Switch Withstand and Closing Ratings](#)

 [Performance Testing for Transfer Switches](#)

Additional SERIES 300 Product Information

Transfer Switches and Panels	Controls	Technical Information
Manual Transfer Switch	Group G Controller	Withstand and Closing Ratings
Manual Transfer Switch with Quick Connects		Weights and Dimensions and Ordering Info
Quick Connect Power Panel		Drawings
Dual Purpose Quick Connect Power Panel		Wiring Diagrams

SERIES 300 Manual Transfer Switching and Quick Connection Solutions

ASCO SERIES 300 Manual Transfer Switching and Quick Connection Solutions offer reliable service and application flexibility for a wide range of facilities.

Manual Transfer Switches



- Three-position, easy-to-use center-off switch
- Compact design - easy to install and maintain
- Designed to handle demands of motors and inrush currents

Power Knowledge

[Differences Between Manual, Non-Automatic, & Automatic Transfer Switches](#)

Product Details

[SERIES 300 Manual Transfer Switch](#)

Quick Connect Panels



- Listed to UL 1008 Transfer Switch Accessory standard
- Utilizes standard Cam-Lok™ receptacles for quick connections
- Standard Type 3R construction is weatherproof with or without cable
- Utilizes standard Series 16 Single Pole quick connect receptacles

Power Knowledge

[NEC Requirement for Permanent Manual Switching Means](#)

Product Details

[SERIES 300 Quick Connect Power Panel](#)

Manual Transfer Switches with Quick Connects



- The ASCO SERIES 300 Manual Transfer Switch with Integrated Quick Connects provides a total temporary power connection and transfer solution
- Enables connection and control of a temporary or portable generator
- Provides a complete UL 1008-listed solution in a single unit

Product Details

[SERIES 300 Manual Transfer Switch with Quick Connects](#)

Dual-Purpose Manual Transfer Switches with Quick Connects



- Provides both supplemental backup power and load testing connectivity through a single device.
- Listed by ETL to UL 891
- Utilizes standard Series 16 Single Pole quick connect receptacles

Product Details

[SERIES 300 Dual Purpose Quick Connect Power Panel](#)

Life Is On | **Schneider**
Electric™

ASCO Power Technologies - Global Headquarters
160 Park Avenue
Florham Park, NJ 07932
Tel: 800 800 ASCO

www.ascopower.com
customercare@ascopower.com