

DIESEL GENERATOR SET

MTU 8V1600 DS400

400 kWe / 60 Hz / Standby
208 - 600V

Reference MTU 8V1600 DS400 (365 kWe) for Prime Rating Technical Data



SYSTEM RATINGS

Standby

Voltage (L-L)	208V*	240V*	380V	440V	480V*	600V*
Phase	3	3	3	3	3	3
PF	0.8	0.8	0.8	0.8	0.8	0.8
Hz	60	60	60	60	60	60
kW	400	400	400	400	400	400
kVA	500	500	500	500	500	500
Amps	1388	1203	760	656	601	481
skVA@30%						
Voltage Dip	800	820	640	920	1277	1100
Generator Model	572RSL4025	572RSL4025	572RSL4025	433CSL6220	433CSL6220	433PSL6248
Temp Rise	130 °C/40 °C	130 °C/40 °C	130 °C/40 °C	130 °C/40 °C	130 °C/40 °C	130 °C/40 °C
Connection	12 LEAD WYE	12 LEAD DELTA	12 LEAD WYE	12 LEAD WYE	12 LEAD WYE	4 LEAD WYE

* UL 2200 Offered

CERTIFICATIONS AND STANDARDS

// Emissions – EPA Tier 3 Certified

// Generator set is designed and manufactured in facilities certified to standards ISO 9001:2008 and ISO 14001:2004

// Seismic Certification – Optional

- IBC Certification
- OSHPD Pre-Approval

// UL 2200 / CSA – Optional

- UL 2200 Listed
- CSA Certified

// Performance Assurance Certification (PAC)

- Generator Set Tested to ISO 8528-5 for Transient Response
- Verified product design, quality and performance integrity
- All engine systems are prototype and factory tested

// Power Rating

- Accepts Rated Load in One Step Per NFPA 110
- Permissible average power output during 24 hours of operation is approved up to 85%.

STANDARD FEATURES*

- // MTU Onsite Energy is a single source supplier
- // Global Product Support
- // 2 Year Standard Warranty
- // 8V1600 Diesel Engine
 - 14.0 Liter Displacement
 - Common Rail Fuel Injection
 - 4-Cycle
- // Engine-generator resilient mounted
- // Complete Range of Accessories
- // Generator
 - Brushless, Rotating Field Generator
 - 2/3 Pitch Windings
 - 300% Short Circuit Capability with Permanent Magnet Generator (PMG)
 - o PMG Standard for 570 frame and larger
 - o PMG Optional for 430 frame and smaller
- // Digital Control Panel(s)
 - UL Recognized, CSA Certified, NFPA 110
 - Complete System Metering
 - LCD Display
- // Cooling System
 - Integral Set-Mounted
 - Engine-Driven Fan

STANDARD EQUIPMENT*

// Engine

Air Cleaners
 Oil Pump
 Oil Drain Extension and S/O Valve
 Full Flow Oil Filters
 Closed Crankcase Ventilation
 Jacket Water Pump
 Thermostats
 Blower Fan and Fan Drive
 Radiator - Unit Mounted
 Electric Starting Motor - 24V
 Governor - Electronic Isochronous
 Base - Formed Steel
 SAE Flywheel and Bell Housing
 Charging Alternator - 24V
 Battery Box and Cables
 Flexible Fuel Connectors
 Flexible Exhaust Connection
 EPA Certified Engine

// Generator

NEMA MG1, IEEE and ANSI standards compliance for temperature rise and motor starting
 Sustained short circuit current of up to 300% of the rated current for up to 10 seconds
 Self-Ventilated
 Superior Voltage Waveform
 Digital, Solid State, Volts-per-Hertz Regulator
 No Load to Full Load Regulation

Brushless Alternator with Brushless Pilot Exciter
 4 Pole, Rotating Field
 130 °C Max. Standby Temperature Rise
 1 Bearing, Sealed
 Flexible Coupling
 Full Amortisseur Windings
 125% Rotor Balancing
 3-Phase Voltage Sensing
 ±0.25% Voltage Regulation (570 frame)
 ±1% Voltage Regulation (430 frame)
 100% of Rated Load - One Step
 5% Max. Total Harmonic Distortion

// Digital Control Panel(s)

Digital Metering
 Engine Parameters
 Generator Protection Functions
 Engine Protection
 CANBus ECU Communications
 Windows®-Based Software
 Multilingual Capability
 Remote Communications to RDP-110 Remote Annunciator
 Programmable Input and Output Contacts
 UL Recognized, CSA Certified, CE Approved
 Event Recording
 IP 54 Front Panel Rating with Integrated Gasket
 NFPA110 Compatible

* Represents standard product only. Consult Factory/MTU Onsite Energy Distributor for additional configurations.

APPLICATION DATA

// Engine

Manufacturer	MTU
Model	8V1600G80S
Type	4-Cycle
Arrangement	8-V
Displacement: L (Cu In)	14 (854)
Bore: cm (in)	12.2 (4.8)
Stroke: cm (in)	15 (5.91)
Compression Ratio	17.5:1
Rated RPM	1,800
Engine Governor	Electronic Isochronous (ADEC)
Max. Power: kWm (bhp)	448 (601)
Speed Regulation	±0.25%
Air Cleaner	Dry

// Liquid Capacity (Lubrication)

Total Oil System: L (gal)	46 (12.2)
Engine Jacket Water Capacity: L (gal)	50 (13.2)
System Coolant Capacity: L (gal)	80.3 (21.2)

// Electrical

Electric Volts DC	24
Cold Cranking Amps Under -17.8 °C (0 °F)	1,050

// Fuel System

Fuel Supply Connection Size	-10 JIC 37° Female M20 x 1.5 Male Adapter Provided
Fuel Return Connection Size	-6 JIC 37° Female M14 x 1.5 Male Adapter Provided
Max. Fuel Lift: m (ft)	5 (16)
Recommended Fuel	Diesel #2
Total Fuel Flow: L/hr (gal/hr)	402 (106)

// Fuel Consumption

At 100% of Power Rating: L/hr (gal/hr)	109 (28.8)
At 75% of Power Rating: L/hr (gal/hr)	88 (23.4)
At 50% of Power Rating: L/hr (gal/hr)	68 (18)

// Cooling - Radiator System

Ambient Capacity of Radiator: °C (°F)	50 (122)
Max. Restriction of Cooling Air: Intake and Discharge Side of Rad.: kPa (in. H ₂ O)	0.2 (0.8)
Water Pump Capacity: L/min (gpm)	362 (95)
Heat Rejection to Coolant: kW (BTUM)	205 (11,658)
Heat Rejection to After Cooler: kW (BTUM)	120 (6,824)
Heat Radiated to Ambient: kW (BTUM)	48.1 (2,735)
Fan Power: kW (hp)	17.1 (22.9)

// Air Requirements

Aspirating: *m ³ /min (SCFM)	36 (1,271)
Air Flow Required for Rad. Cooled Unit: *m ³ /min (SCFM)	510 (18,010)
Remote Cooled Applications; Air Flow Required for Dissipation of Radiated Generator Set Heat for a Max. of 25 °F Rise: *m ³ /min (SCFM)	174.7 (6,169)

* Air density = 1.184 kg/m³ (0.0739 lbm/ft³)

// Exhaust System

Gas Temp. (Stack): °C (°F)	466 (871)
Gas Volume at Stack Temp: m ³ /min (CFM)	85.2 (3,008)
Max. Allowable Back Pressure: kPa (in. H ₂ O)	15 (61)

WEIGHTS AND DIMENSIONS

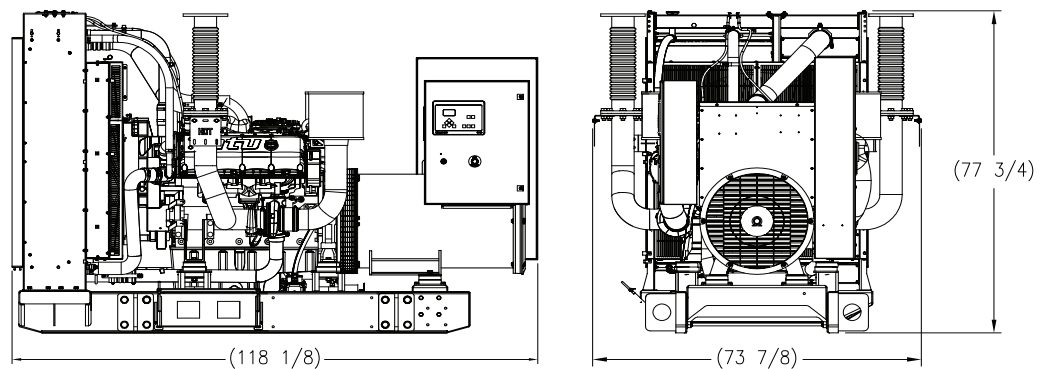

Drawing above for illustration purposes only, based on standard open power 480 volt generator set. Lengths may vary with other voltages. Do not use for installation design. See website for unit specific template drawings.

System

Open Power Unit (OPU)

Dimensions (L x W x H)

3,001 x 1,877 x 1,975 mm (118.13 x 73.88 x 77.75 in)

Weight (dry/less tank)

3,785-4,602 kg (8,343-10,146 lb)

Weights and dimensions are based on open power units and are estimates only. Consult the factory for accurate weights and dimensions for your specific generator set.

SOUND DATA

Unit Type

Level 0: Open Power Unit dB(A)

Standby Full Load

88.6

Sound data is provided at 7 m (23 ft). Generator set tested in accordance with ISO 8528-10 and with infinite exhaust.

EMISSIONS DATA

NO_x + NMHC

5.01

CO

0.52

PM

0.04

All units are in g/hp-hr and shown at 100% load (not comparable to EPA weighted cycle values).

Emission levels of the engine may vary with ambient temperature, barometric pressure, humidity, fuel type and quality, installation parameters, measuring instrumentation, etc. The data was obtained in compliance with US EPA regulations. The weighted cycle value (not shown) from each engine is guaranteed to be within the US EPA Standards.

RATING DEFINITIONS AND CONDITIONS

// Standby ratings apply to installations served by a reliable utility source. The standby rating is applicable to varying loads for the duration of a power outage. No overload capability for this rating. Ratings are in accordance with ISO 8528-1, ISO-3046-1, BS 5514, and AS 2789. Average load factor: ≤ 85%.

// Deration Factor:

Altitude: Consult your local MTU Onsite Energy Power Generation Distributor for altitude derations.

Temperature: Consult your local MTU Onsite Energy Power Generation Distributor for temperature derations.

C/F = Consult Factory/MTU Onsite Energy Distributor

N/A = Not Available

MTU Onsite Energy

A Rolls-Royce Power Systems Brand

www.mtuonsiteenergy.com