

Exclusively from your Caterpillar® dealer

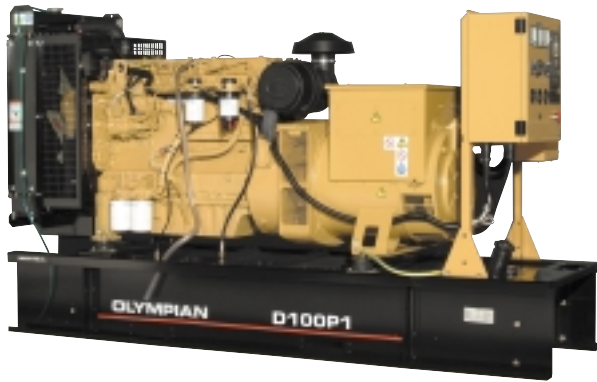

STANDBY 90-150 kW  
PRIME 82.4-114 kW  
60 Hz

Model	Standby kW (kVA)	Prime kW (kVA)
D90P1**	90 (112.5)	82.4 (103)
D100P1**	100 (125)	90 (112.5)
D100P4*	100 (125)	90 (112.5)
D125P1**	125 (156.3)	114 (142.5)
D125P2*	125 (156.3)	114 (142.5)
D150P1**	150 (188)	N/A

\*Tier II EPA Approved, Emissions Certified

\*\*50 Hz option is available. Consult factory for more details.

## FEATURES

### GENERATOR SET

- Complete system designed and built at ISO 9001 certified facilities
- Factory tested to design specifications at full load conditions

### ENGINE

- Governor, electronic (D125P1, D125P2, D150P1)
- Governor, mechanical (D90P1, D100P1, D100P4)
- Electrical system, 12 VDC
- Cartridge type filters
- Battery(ies), rack and cables
- Coolant and lube drains piped to edge of base

### GENERATOR

- Insulation system, class H
- Drip proof generator air intake (NEMA 2, IP23)
- Electrical design in accordance with BS5000 Part 99, EN61000-6, IEC60034-1, NEMA MG-1.33

### CONTROL SYSTEM

- 2001 Autostart control panel
- Vibration isolated NEMA 1 enclosure with lockable hinged door
- DC and AC wiring harnesses

### MOUNTING ARRANGEMENT

- Heavy-duty fabricated steel base with lifting points
- Anti-vibration pads to ensure vibration isolation
- Complete OSHA guarding
- Flexible fuel lines to base with NPT connections
- Stub-up pipe ready for connection to silencer pipework

### COOLING SYSTEM

- Radiator and cooling fan complete with protective guards
- Standard ambient temperatures up to 122° F (50° C)

### CIRCUIT BREAKER

- UL/CSA listed
- 3-pole with solid neutral
- NEMA 1 steel enclosure, vibration isolated
- Electrical stub-up area directly below circuit breaker

### AUTOMATIC VOLTAGE REGULATOR

- Voltage within  $\pm 0.5\%$  at steady state from no load to full load
- Provides fast recovery from transient load changes

### EQUIPMENT FINISH

- All electroplated hardware
- Anticorrosive paint protection
- High gloss polyurethane paint for durability and scuff resistance

### QUALITY STANDARDS

- BS4999, BS5000, BS5514, EN61000-6, IEC60034, NEMA MG-1.33, NFPA 110 (with optional equipment)

### DOCUMENTATION

- Operation and maintenance manuals provided
- Wiring diagrams included

### WARRANTY

- All equipment carries full manufacturer's warranty. Extended warranty terms available.

**STANDBY 90 - 150 kW**  
**PRIME 82.4 - 114 kW**  
**60 Hz**

**OLYMPIAN™**

**OPTIONAL EQUIPMENT\***

**ENCLOSURE**

- B Series weather protective enclosure (includes internal silencer system)
  - Single point lift
  - Panel viewing window
  - External emergency stop pushbutton
- Sound attenuated enclosure (includes internal silencer system)
- Super sound attenuated enclosure (includes internal silencer system) (D90P1, D100P1)

**SILENCER SYSTEM — OPEN UNIT**

- Level 1 silencer 10 dBA
- Level 2 silencer 25 dBA
- Level 3 silencer 35 dBA
- Mounting kit
- Through-wall installation kits

**ENGINE**

- Electronic governor (fully adjustable)
- Battery heater
- Lube oil drain pump
- High lube oil temperature shutdown
- Lube oil sump heater

**CIRCUIT BREAKER**

- Auxiliary voltfree contacts
- Shunt trip (100+ amp breakers)

**GENERATOR**

- Anti-condensation heater
- Permanent magnet generator
- AREP excitation system
- Generator upgrade 1 size - except D150P1

**CONTROL SYSTEM**

- No control system
- 4001 Series Autostart control panel
- 4001E Series Autostart control panel
- Access 4000 digital control panel

**MOUNTING ACCESSORIES**

- Seismic Zone 4 vibration isolators

**FUEL SYSTEM**

- Metal fuel tank
- UL listed closed top-diked skid-mounted fuel tank base (12/24-hour capacity) with fuel alarm (low level/leak detected)
- Critical high fuel alarm
- Critical low fuel level shutdown

**REMOTE ANNUNCIATORS**

- 8- and 16-channel remote annunciator panel (supplied loose)
- Remote annunciator upgrade normal/run control switch
- Remote annunciator upgrade lockdown emergency stop button

**COOLING SYSTEM**

- Coolant heater
- Low coolant temperature alarm
- Low coolant level shutdown
- Radiator transition flange

**MISCELLANEOUS ACCESSORIES**

- Toolkit
- Additional operator's manual pack
- Special enclosure color
- UL listing
- CSA certification
- French or Spanish language labels

**EXTENDED WARRANTY**

- 36 months
  - 48 months
  - 60 months
- (See warranty policy for details of coverage)

**TESTING**

- Factory witness test (restricted to 6 hours — full load, 1.0 pf)

\*Some options may not be available on all models. Not all options are listed.

**GENERATOR SET DIMENSIONS AND WEIGHTS**

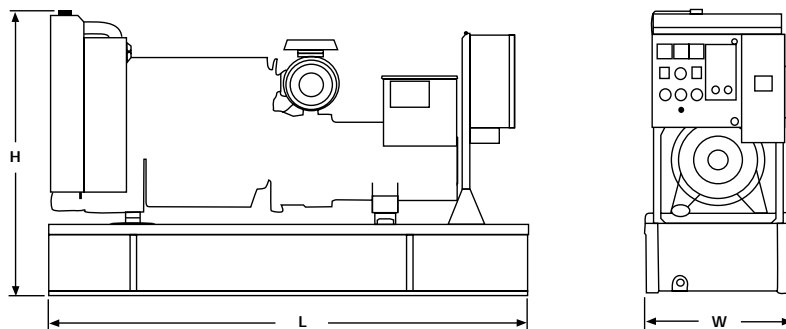

Model	Length in (mm)	Width in (mm)	Height in (mm)	Weight lbs (kg)**
D90P1	97.8 (2485)	29.5 (750)	56.5 (1435)	2695 (1222)
D100P1	97.8 (2485)	29.5 (750)	56.5 (1435)	2734 (1240)
D100P4	102.4 (2600)	43.3 (1100)	50.6 (1284)	2977 (1353) <sup>∞</sup>
D125P1	106 (2700)	35.4 (900)	57.5 (1460)	3263 (1480)
D125P2	106 (2700)	35.4 (900)	57.5 (1460)	3263 (1480)
D150P1	106 (2700)	35.4 (900)	57.5 (1460)	3384 (1535)

**NOTE:** General configuration not to be used for installation. See specific dimensional drawings for detail.

\*\*Includes oil and coolant  
<sup>∞</sup> Estimated weight

**SPECIFICATIONS**



**GENERATOR**

Voltage Regulation . . . . . ±0.5% at steady state from no load to full load  
 Frequency . . . ±0.8% (models with mechanical governor) ±0.25% (models with electronic governor) for constant load, no load to full load  
 Waveform Distortion . . . . . THD < 4%, at no load  
 Radio Interference . . . . . Compliance with EN61000-6  
 Telephone Interference . . . . . TIF <50, THF <2%  
 Overspeed Limit . . . . . 2250 rpm  
 Insulation . . . . . Class H  
 Temperature Rise . . . . . Within Class H limits  
 Available Voltages . . . . . 277/480, 266/460, 120/240, 127/220, 120/208, 347/600  
 Deration . . . . . Consult factory for available outputs  
 Ratings . . . . . At 86° F (30° C), 500 ft. (152.4 m), 60% humidity, 0.8 pf



**ENGINE**

**D90P1, D100P1, D125P1, D125P2 D150P1 — 1006 SERIES**

Manufacturer . . . . . Perkins  
 Type . . . . . 4-Cycle  
 Cylinder Configuration . . . . . In-line 6  
 Displacement — cu in (L) . . . . . 365 (5.99)  
 Bore — in (mm) . . . . . 3.94 (100.0)  
 Stroke — in (mm) . . . . . 5.00 (127.0)  
 Compression Ratio  
     D90P1, D100P1 . . . . . 16.0:1  
     D125P1, D125P2, D150P1 . . . . . 17.0:1  
 Governor  
     Type . . . . . Mechanical/Electronic  
     Class . . . . . A1/G2  
 Piston Speed — ft/sec (m/sec) . . . . . 25.0 (7.62)  
 Engine speed — rpm . . . . . 1800  
 Air Cleaner Type . . . . . Dry, replaceable paper element type with restriction indicator  
 Regenerative Power — kW . . . . . 16.2

**D100P4 — 1100 SERIES**

Manufacturer . . . . . Perkins  
 Type . . . . . 4-Cycle  
 Cylinder Configuration . . . . . In-line 4  
 Displacement — cu in (L) . . . . . 365 (5.99)  
 Bore — in (mm) . . . . . 4.13 (105)  
 Stroke — in (mm) . . . . . 5.00 (127)  
 Compression Ratio . . . . . 19.3:1  
 Governor  
     Type . . . . . Electronic  
     Class . . . . . A1  
 Piston Speed — ft/sec (m/sec) . . . . . 25.0 (7.62)  
 Engine speed — rpm . . . . . 1800  
 Air Cleaner Type . . . . . Dry, replaceable paper element type with restriction indicator  
 Regenerative Power — kW . . . . . 16.2

**RATING DEFINITIONS**

**Standby** — Applicable for supplying continuous electrical power (at variable load) in the event of a utility power failure. No overload is permitted on these ratings. The generator is peak rated (as defined in ISO8528-3).

**D90P1 — 1006TG1A**

Max Power at Rated rpm — hp (kW)  
     Standby . . . . . 149.8 (111.7)  
     Prime . . . . . 136.2 (101.6)  
 BMEP — psi (kPa)  
     Standby . . . . . 182 (1259)  
     Prime . . . . . 164 (1133)  
 Aspiration . . . . . Turbocharged

**D100P1 — 1006TG2A**

Max Power at Rated rpm — hp (kW)  
     Standby . . . . . 166 (124)  
     Prime . . . . . 151 (112)  
 BMEP — psi (kPa)  
     Standby . . . . . 202 (1393)  
     Prime . . . . . 182 (1253)  
 Aspiration . . . . . Turbocharged

**D100P4 — 1104C-TAG2**

Max Power at Rated rpm — hp (kW)  
     Standby . . . . . 157.5 (117.5)  
     Prime . . . . . 143.2 (106.9)  
 BMEP — psi (kPa)  
     Standby . . . . . 258 (1780)  
     Prime . . . . . 235 (1618)  
 Aspiration . . . . . Turbocharged

**D125P1 — 1006TAG**

Max Power at Rated rpm — hp (kW)  
     Standby . . . . . 212.1 (158.5)  
     Prime . . . . . 193.8 (144.2)  
 BMEP — psi (kPa)  
     Standby . . . . . 266 (1836)  
     Prime . . . . . 234 (1610)  
 Aspiration . . . . . Turbocharged, AA Charge Cooled

**D125P2 — 1006-6 TA**

Max Power at Rated rpm — hp (kW)  
     Standby . . . . . 212.1 (158.5)  
     Prime . . . . . 193.8 (144.2)  
 BMEP — psi (kPa)  
     Standby . . . . . 266 (1836)  
     Prime . . . . . 233 (1610)  
 Aspiration . . . . . Turbocharged, AA Charge Cooled

**D150P1 — 1006TAG1**

Max Power at Rated rpm — hp (kW)  
     Standby . . . . . 244 (182)  
     Prime . . . . . N/A  
 BMEP — psi (kPa)  
     Standby . . . . . 294 (2026)  
     Prime . . . . . N/A  
 Aspiration . . . . . Turbocharged, AA Charge Cooled



**CONTROL PANEL**

NEMA 1 steel enclosure with lockable hinged door  
 Vibration isolated mounted Autostart control panel  
 Single location customer connector point  
 Electrical stub-up area directly below control panel

**Prime** — Applicable for supplying continuous electrical power (at variable load) in lieu of commercially purchased power. There is no limitation to the annual hours of operation and the generator set can supply 10 percent overload power for 1 hour in 12 hours.

**Consult your Olympian representative for more information.**

www.CAT-ElectricPower.com  
 © 2003 Caterpillar  
 All rights reserved.  
 Printed in U.S.A.

Materials and specifications are subject to change without notice.  
 The International System of Units (SI) is used in this publication.

**STANDBY 90 kW**  
**PRIME 82.4 kW**  
**60 Hz**

**OLYMPIAN™**

**D90P1 (3-Phase)**

Materials and specifications are subject to change without notice.

Generator Set Technical Data — 1800 rpm/60 Hz		Standby	Prime
Power Rating	kW (kVA)	90 (112.5)	82.4 (103.0)
<b>Lubricating System</b> Type: Full Pressure Oil Filter: Spin-On, Full Flow Oil Cooler: Watercooled Oil Type Required: API CF-4 Total Oil Capacity Oil Pan	U.S. gal (L) U.S. gal (L)	4.3 (16.1) 3.5 (13.1)	4.3 (16.1) 3.5 (13.1)
<b>Fuel System</b> Generator Set Fuel Consumption 100% Load 75% Load 50% Load	G/hr (L/hr) G/hr (L/hr) G/hr (L/hr)	7.15 (27.07) 5.60 (21.18) 4.07 (15.42)	6.57 (24.86) 4.98 (18.69) 3.61 (13.67)
<b>Engine Electrical System</b> Voltage/Ground: 12/Negative Battery Charging Generator Ampere Rating	Amps	45	45
<b>Cooling System</b> Water Pump Type: Centrifugal Radiator System Capacity Incl. Engine Maximum Coolant Static Head Coolant Flow Rate Minimum Temperature to Engine Temperature Rise Across Engine Heat Rejected to Coolant at Rated Power Total Heat Radiated to Room at Rated Power Radiator Fan Load	U.S. gal (L) Ft H <sub>2</sub> O (m H <sub>2</sub> O) U.S. gal/hr (L/hr) °F (°C) °F (°C) Btu/min (kW) Btu/min (kW) Hp (kW)	7.3 (27.7) 26.2 (8.0) 2664 (10 080) 158 (70) 13.9 (7.7) 4129 (72.6) 2224 (39.1) 9.8 (7.3)	7.3 (27.7) 26.2 (8.0) 2664 (10 080) 158 (70) 13.9 (7.7) 3726 (65.5) 1826 (32.1) 9.8 (7.3)
<b>Air Requirements</b> Combustion Air Flow Maximum Air Cleaner Restriction Radiator Cooling Air (zero restriction) Generator Cooling Air Allowable Air Flow Restriction (After radiator) Cooling Airflow (@ rated speed) Rate with restriction	Cfm (m <sup>3</sup> /min) In H <sub>2</sub> O (kPa) Cfm (m <sup>3</sup> /min) Cfm (m <sup>3</sup> /min) In H <sub>2</sub> O (kPa) Cfm (m <sup>3</sup> /min)	257 (7.3) 20 (5.0) 10,500 (300) 933 (26.4) 0.48 (0.120) 8686 (300)	245 (7.0) 20 (5.0) 10,500 (300) 933 (26.4) 0.48 (0.120) 8686 (300)
<b>Exhaust System</b> Maximum Allowable Backpressure Exhaust Flow at Rated kW Exhaust Temperature at Rated kW — Dry Exhaust	In Hg (kPa) Cfm (m <sup>3</sup> /min) °F (°C)	1.8 (6.0) 744 (21.1) 1063 (573)	1.8 (6.0) 686 (19.4) 1004 (540)
<b>Generator Set Noise Rating*</b> (Without Attenuation) at 3 ft (1 m)	dB(A)	95	95

Generator Technical Data	277/480V	266/460V	127/220V	120/240V 120/208V	347/600V
<b>Motor Starting Capability:</b> (kVA) (30% Voltage Dip)					
Self Excited	206	191	177	160	N/A
PM Excited**	271	252	233	211	271
AREP Excited	271	252	233	211	271
<b>Full Load Efficiencies:</b>					
Standby	91.4	91.0	90.9	90.4	91.4
Prime	91.7	91.4	91.1	90.9	91.7
<b>Reactances (per unit):</b>					
X <sub>d</sub>	3.26	3.55	3.88	4.34	3.26
X' <sub>d</sub>	0.12	0.13	0.14	0.16	0.12
Reactances shown are applicable to the standby rating.					
X'' <sub>d</sub>	0.072	0.078	0.086	0.096	0.072
X <sub>q</sub>	1.96	2.13	2.33	2.61	1.96
X'' <sub>q</sub>	0.091	0.099	0.108	0.121	0.091
X <sub>2</sub>	0.082	0.089	0.097	0.109	0.082
X <sub>0</sub>	0.005	0.006	0.006	0.007	0.005
<b>Time Constants:</b>	t' <sub>d</sub> 100 ms	t' <sub>d</sub> 10 ms	t' <sub>do</sub> 2555 ms	t <sub>a</sub> 15 ms	

\* dB(A) levels are for guidance only  
 \*\* With PMG Excited Option AVR12

**STANDBY 100 kW**  
**PRIME 90 kW**  
**60 HZ**

**OLYMPIAN™**

**D100P1 (3-Phase)**

Materials and specifications are subject to change without notice.

Generator Set Technical Data — 1800 rpm/60 Hz		Standby	Prime
Power Rating	kW (kVA)	100 (125.0)	90 (112.5)
<b>Lubricating System</b>			
Type: Full Pressure			
Oil Filter: Spin-On, Full Flow			
Oil Cooler: Watercooled			
Oil Type Required: API CF-4			
Total Oil Capacity	U.S. gal (L)	4.3 (16.1)	4.3 (16.1)
Oil Pan	U.S. gal (L)	3.5 (13.1)	3.5 (13.1)
<b>Fuel System</b>			
Generator Set Fuel Consumption			
100% Load	G/hr (L/hr)	8.07 (30.53)	7.30 (27.63)
75% Load	G/hr (L/hr)	6.19 (23.42)	5.54 (20.99)
50% Load	G/hr (L/hr)	4.48 (16.95)	4.01 (15.19)
<b>Engine Electrical System</b>			
Voltage/Ground: 12/Negative			
Battery Charging Generator Ampere Rating	Amps	45	45
<b>Cooling System</b>			
Water Pump Type: Centrifugal			
Radiator System Capacity Incl. Engine	U.S. gal (L)	7.3 (27.7)	7.3 (27.7)
Maximum Coolant Static Head	Ft H <sub>2</sub> O (m H <sub>2</sub> O)	26.2 (8.0)	26.2 (8.0)
Coolant Flow Rate	U.S. gal/hr (L/hr)	2664 (10 080)	2664 (10 080)
Minimum Temperature to Engine	°F (°C)	158 (70)	158 (70)
Temperature Rise Across Engine	°F (°C)	13.9 (7.7)	13.9 (7.7)
Heat Rejected to Coolant at Rated Power	Btu/min (kW)	4550 (80.0)	4095 (72.0)
Total Heat Radiated to Room at Rated Power	Btu/min (kW)	2361 (41.5)	1917 (33.7)
Radiator Fan Load	Hp (kW)	9.8 (7.3)	9.8 (7.3)
<b>Air Requirements</b>			
Combustion Air Flow	Cfm (m <sup>3</sup> /min)	275 (7.8)	261 (7.4)
Maximum Air Cleaner Restriction	In H <sub>2</sub> O (kPa)	20 (5.0)	20 (5.0)
Radiator Cooling Air (zero restriction)	Cfm (m <sup>3</sup> /min)	10,500 (300)	10,500 (300)
Generator Cooling Air	Cfm (m <sup>3</sup> /min)	933 (26.4)	933 (26.4)
Allowable Air Flow Restriction (After radiator)	In H <sub>2</sub> O (kPa)	0.48 (0.120)	0.48 (0.120)
Cooling Airflow (@ rated speed)			
Rate with restriction	Cfm (m <sup>3</sup> /min)	8686 (300)	8686 (300)
<b>Exhaust System</b>			
Maximum Allowable Backpressure	In Hg (kPa)	1.8 (6.0)	1.8 (6.0)
Exhaust Flow at Rated kW	Cfm (m <sup>3</sup> /min)	794 (22.5)	705 (20.0)
Exhaust Temperature at Rated kW — Dry Exhaust	°F (°C)	1076 (580)	1004 (540)
<b>Generator Set Noise Rating*</b> (Without Attenuation) at 3 ft (1 m)			
	dB(A)	95	95

Generator Technical Data	277/480V	266/460V	127/220V	120/240V 120/208V	347/600V
<b>Motor Starting Capability: (kVA)</b> (30% Voltage Dip)					
Self Excited	206	191	177	160	N/A
PM Excited**	271	252	233	211	271
AREP Excited	271	252	233	211	271
<b>Full Load Efficiencies:</b>					
Standby	91.0	90.9	90.5	90.0	91.0
Prime	91.4	91.0	90.9	90.4	91.4
<b>Reactances (per unit):</b>					
X <sub>d</sub>	3.58	3.90	4.26	4.77	3.58
X' <sub>d</sub>	0.14	0.15	0.17	0.19	0.14
X'' <sub>d</sub>	0.083	0.091	0.099	0.111	0.083
X <sub>q</sub>	2.15	2.34	2.56	2.86	2.15
X'' <sub>q</sub>	0.104	0.113	0.123	0.138	0.104
X <sub>2</sub>	0.094	0.102	0.112	0.125	0.094
X <sub>0</sub>	0.005	0.005	0.006	0.006	0.005
<b>Time Constants:</b>					
	t' <sub>d</sub> 100 ms	t'' <sub>d</sub> 10 ms	t' <sub>do</sub> 2555 ms	t <sub>a</sub> 15 ms	

\* dB(A) levels are for guidance only  
 \*\* With PMG Excited Option AVR12

**STANDBY 100 kW**  
**PRIME 90 kW**  
**60 HZ**

**OLYMPIAN™**

**D100P4 (3-Phase)**

Materials and specifications are subject to change without notice.

Generator Set Technical Data — 1800 rpm/60 Hz		Standby	Prime
Power Rating	kW (kVA)	100 (125.0)	90 (112.5)
<b>Lubricating System</b> Type: Full Pressure Oil Filter: Spin-On, Full Flow Oil Cooler: Watercooled Oil Type Required: API CG4/CH4 Total Oil Capacity Oil Pan	U.S. gal (L) U.S. gal (L)	2.1 (8.0) 1.4 (5.5)	2.1 (8.0) 1.4 (5.5)
<b>Fuel System</b> Generator Set Fuel Consumption 100% Load 75% Load 50% Load	G/hr (L/hr) G/hr (L/hr) G/hr (L/hr)	7.9 (29.8) 5.9 (22.5) 4.2 (15.8)	7.1 (26.8) 5.4 (20.4) 3.9 (14.6)
<b>Engine Electrical System</b> Voltage/Ground: 12/Negative Battery Charging Generator Ampere Rating	Amps	65	65
<b>Cooling System</b> Water Pump Type: Centrifugal Radiator System Capacity Incl. Engine Maximum Coolant Static Head Coolant Flow Rate Minimum Temperature to Engine Temperature Rise Across Engine Heat Rejected to Coolant at Rated Power Total Heat Radiated to Room at Rated Power Radiator Fan Load	U.S. gal (L) Ft H <sub>2</sub> O (m H <sub>2</sub> O) U.S. gal/hr (L/hr) °F (°C) °F (°C) Btu/min (kW) Btu/min (kW) Hp (kW)	3.3 (12.6) 33.5 (10.2) 3075 (11640) 158 (70) 9.9 (5.5) 3731 (65.6) 1177 (20.7) 6.7 (5.0)	3.3 (12.6) 33.5 (10.2) 3075 (11640) 158 (70) 9.0 (5.0) 3396 (59.7) 1041 (18.3) 6.7 (5.0)
<b>Air Requirements</b> Combustion Air Flow Maximum Air Cleaner Restriction Radiator Cooling Air (zero restriction) Generator Cooling Air Allowable Air Flow Restriction (After radiator) Cooling Airflow (@ rated speed) Rate with restriction	Cfm (m <sup>3</sup> /min) In H <sub>2</sub> O (kPa) Cfm (m <sup>3</sup> /min) Cfm (m <sup>3</sup> /min) In H <sub>2</sub> O (kPa) Cfm (m <sup>3</sup> /min)	276 (78) 32 (8) 9746 (276) 933 (26.4) 0.48 (0.120) 8616 (244)	274 (7.75) 32 (8) 9746 (276) 933 (26.4) 0.48 (0.120) 8616 (244)
<b>Exhaust System</b> Maximum Allowable Backpressure Exhaust Flow at Rated kW Exhaust Temperature at Rated kW — Dry Exhaust	In Hg (kPa) Cfm (m <sup>3</sup> /min) °F (°C)	4.5 (15) 721 (20.4) 1065 (574)	4.5 (15) 651 (18.4) 963 (517)
<b>Generator Set Noise Rating*</b> (Without Attenuation) at 3 ft (1 m)	dB(A)	95	95

Generator Technical Data	277/480V	266/460V	127/220V	120/240V 120/208V	347/600V
<b>Motor Starting Capability:</b> (kVA) (30% Voltage Dip)					
Self Excited	206	191	177	160	N/A
PM Excited**	271	252	233	211	271
AREP Excited	271	252	233	211	271
<b>Full Load Efficiencies:</b>					
Standby	91.0	90.9	90.5	90.0	91.0
Prime	91.4	91.0	90.9	90.4	91.4
<b>Reactances (per unit):</b>					
X <sub>d</sub>	3.58	3.90	4.26	4.77	3.58
X' <sub>d</sub>	0.14	0.15	0.17	0.19	0.14
X'' <sub>d</sub>	0.083	0.091	0.099	0.111	0.083
X <sub>q</sub>	2.15	2.34	2.56	2.86	2.15
X'' <sub>q</sub>	0.104	0.113	0.123	0.138	0.104
X <sub>2</sub>	0.094	0.102	0.112	0.125	0.094
X <sub>0</sub>	0.005	0.005	0.006	0.006	0.005
<b>Time Constants:</b>	t' <sub>d</sub> 100 ms	t'' <sub>d</sub> 10 ms	t' <sub>do</sub> 2555 ms	t <sub>a</sub> 15 ms	

\* dB(A) levels are for guidance only

\*\* With PMG Excited Option AVR12

**STANDBY 125 kW**  
**PRIME 114 kW**  
**60 Hz**

**OLYMPIAN™**

**D125P1 (3-Phase)**

Materials and specifications are subject to change without notice.

Generator Set Technical Data — 1800 rpm/60 Hz		Standby	Prime
Power Rating	kW (kVA)	125 (156.3)	114 (142.5)
<b>Lubricating System</b> Type: Full Pressure Oil Filter: Spin-On, Full Flow Oil Cooler: Watercooled Oil Type Required: API CF-4 Total Oil Capacity Oil Pan	U.S. gal (L) U.S. gal (L)	5.0 (19) 4.2 (16)	5.0 (19) 4.2 (16)
<b>Fuel System</b> Generator Set Fuel Consumption 100% Load 75% Load 50% Load	G/hr (L/hr) G/hr (L/hr) G/hr (L/hr)	9.88 (37.40) 7.79 (29.47) 5.51 (20.87)	9.12 (34.51) 6.92 (26.22) 5.01 (18.98)
<b>Engine Electrical System</b> Voltage/Ground: 12/Negative Battery Charging Generator Ampere Rating	Amps	45	45
<b>Cooling System</b> Water Pump Type: Centrifugal Radiator System Capacity Incl. Engine Maximum Coolant Static Head Coolant Flow Rate Minimum Temperature to Engine Temperature Rise Across Engine Heat Rejected to Coolant at Rated Power Total Heat Radiated to Room at Rated Power Radiator Fan Load	U.S. gal (L) Ft H <sub>2</sub> O (m H <sub>2</sub> O) U.S. gal/hr (L/hr) °F (°C) °F (°C) Btu/min (kW) Btu/min (kW) Hp (kW)	9.8 (37.2) 32.2 (9.8) 2724 (10 320) 169 (76) 14.4 (8.0) 4363 (76.7) 2551 (44.8) 10 (7.5)	9.8 (37.2) 32.2 (9.8) 2724 (10 320) 169 (76) 14.4 (8.0) 3885 (68.3) 1720 (30.2) 10 (7.5)
<b>Air Requirements</b> Combustion Air Flow Maximum Air Cleaner Restriction Radiator Cooling Air (zero restriction) Generator Cooling Air Allowable Air Flow Restriction (After radiator) Cooling Airflow (@ rated speed) Rate with restriction	Cfm (m <sup>3</sup> /min) In H <sub>2</sub> O (kPa) Cfm (m <sup>3</sup> /min) Cfm (m <sup>3</sup> /min) In H <sub>2</sub> O (kPa) Cfm (m <sup>3</sup> /min)	394 (11.2) 20 (5.0) 9100 (258) 933 (26.4) 0.48 (0.120) 8686 (246)	379 (10.7) 20 (5.0) 9100 (258) 933 (26.4) 0.48 (0.120) 8686 (246)
<b>Exhaust System</b> Maximum Allowable Backpressure Exhaust Flow at Rated kW Exhaust Temperature at Rated kW — Dry Exhaust	In Hg (kPa) Cfm (m <sup>3</sup> /min) °F (°C)	1.8 (6.0) 1109 (31.4) 1024 (551)	1.8 (6.0) 1050 (29.8) 1004 (540)
<b>Generator Set Noise Rating*</b> (Without Attenuation) at 3 ft (1 m)	dB(A)	97	97

Generator Technical Data	277/480V	266/460V	127/220V	120/240V 120/208V	347/600V
<b>Motor Starting Capability:</b> (kVA) (30% Voltage Dip)					
Self Excited	360	335	311	283	N/A
PM Excited**	469	437	406	370	469
AREP Excited	469	437	406	370	469
<b>Full Load Efficiencies:</b>					
Standby	92.6	92.6	92.5	92.2	92.6
Prime	92.8	92.7	92.7	92.5	92.8
<b>Reactances (per unit):</b>					
X <sub>d</sub>	2.74	2.98	3.26	3.65	2.74
Reactances shown are applicable to the standby rating.	X' <sub>d</sub> 0.10	0.11	0.12	0.14	0.10
	X'' <sub>d</sub> 0.060	0.066	0.072	0.080	0.060
	X <sub>q</sub> 1.65	1.79	1.96	2.19	1.65
	X'' <sub>q</sub> 0.072	0.078	0.086	0.096	0.072
	X <sub>2</sub> 0.067	0.073	0.079	0.089	0.067
	X <sub>0</sub> 0.005	0.006	0.006	0.007	0.005
<b>Time Constants:</b>	t' <sub>d</sub> 100 ms	t'' <sub>d</sub> 10 ms	t' <sub>do</sub> 2865 ms	t <sub>a</sub> 15 ms	

\* dB(A) levels are for guidance only

\*\* With PMG Excited Option AVR12

**STANDBY 125 kW**  
**PRIME 114 kW**  
**60 Hz**

**D125P2 (3-Phase)**

Materials and specifications are subject to change without notice.

Generator Set Technical Data — 1800 rpm/60 Hz		Standby	Prime
Power Rating	kW (kVA)	125 (156.3)	114 (142.5)
<b>Lubricating System</b> Type: Full Pressure Oil Filter: Spin-On, Full Flow Oil Cooler: Watercooled Oil Type Required: API CF-4 Total Oil Capacity Oil Pan	U.S. gal (L) U.S. gal (L)	5.0 (19.0) 4.2 (16.0)	5.0 (19.0) 4.2 (16.0)
<b>Fuel System</b> Generator Set Fuel Consumption 100% Load 75% Load 50% Load	G/hr (L/hr) G/hr (L/hr) G/hr (L/hr)	9.88 (37.40) 7.79 (29.47) 5.51 (20.87)	9.12 (34.51) 6.92 (26.22) 5.01 (18.98)
<b>Engine Electrical System</b> Voltage/Ground: 12/Negative Battery Charging Generator Ampere Rating	Amps	45	45
<b>Cooling System</b> Water Pump Type: Centrifugal Radiator System Capacity Incl. Engine Maximum Coolant Static Head Coolant Flow Rate Minimum Temperature to Engine Temperature Rise Across Engine Heat Rejected to Coolant at Rated Power Total Heat Radiated to Room at Rated Power Radiator Fan Load	U.S. gal (L) Ft H <sub>2</sub> O (m H <sub>2</sub> O) U.S. gal/hr (L/hr) °F (°C) °F (°C) Btu/min (kW) Btu/min (kW) Hp (kW)	9.8 (37.2) 32.2 (9.8) 2725 (10 320) 169 (76) 14.4 (8.0) 4363 (76.7) 2551 (44.8) 10 (7.5)	9.8 (37.2) 32.2 (9.8) 2725 (10 320) 169 (76) 14.4 (8.0) 3867 (68.0) 1720 (30.2) 10 (7.5)
<b>Air Requirements</b> Combustion Air Flow Maximum Air Cleaner Restriction Radiator Cooling Air (zero restriction) Generator Cooling Air Allowable Air Flow Restriction (After radiator) Cooling Airflow (@ rated speed) Rate with restriction	Cfm (m <sup>3</sup> /min) In H <sub>2</sub> O (kPa) Cfm (m <sup>3</sup> /min) Cfm (m <sup>3</sup> /min) In H <sub>2</sub> O (kPa) Cfm (m <sup>3</sup> /min)	394 (11.2) 20 (5.0) 9100 (258) 933 (26.4) 0.48 (0.120) 8686 (246)	379 (10.7) 120 (5.0) 9100 (258) 933 (26.4) 0.48 (0.120) 8686 (246)
<b>Exhaust System</b> Maximum Allowable Backpressure Exhaust Flow at Rated kW Exhaust Temperature at Rated kW — Dry Exhaust	In Hg (kPa) Cfm (m <sup>3</sup> /min) °F (°C)	1.8 (6.0) 1109 (31.4) 1024 (551)	1.8 (6.0) 1050 (29.8) 1004 (540)
<b>Generator Set Noise Rating*</b> (Without Attenuation) at 3 ft (1 m)	dB(A)	97	97

Generator Technical Data	277/480V	266/460V	127/220V	120/240V 120/208V	347/600V
<b>Motor Starting Capability:</b> (kVA) (30% Voltage Dip)					
Self Excited	360	335	311	283	N/A
PM Excited**	469	437	406	370	469
AREP Excited	469	437	406	370	469
<b>Full Load Efficiencies:</b>					
Standby	92.6	92.6	92.5	92.2	92.6
Prime	92.8	92.7	92.7	92.5	92.8
<b>Reactances (per unit):</b>					
X <sub>d</sub>	2.74	2.98	3.26	3.65	2.74
X' <sub>d</sub>	0.10	0.11	0.12	0.14	0.10
X'' <sub>d</sub>	0.060	0.066	0.072	0.080	0.060
X <sub>q</sub>	1.65	1.79	1.96	2.19	1.65
X'' <sub>q</sub>	0.072	0.078	0.086	0.096	0.072
X <sub>2</sub>	0.067	0.073	0.079	0.089	0.067
X <sub>0</sub>	0.005	0.006	0.006	0.007	0.005
<b>Time Constants:</b>	t' <sub>d</sub> 100 ms	t'' <sub>d</sub> 10 ms	t' <sub>do</sub> 2865 ms	t <sub>a</sub> 15 ms	

\* dB(A) levels are for guidance only

\*\* With PMG Excited Option AVR12



**STANDBY 150 kW**  
**PRIME N/A**  
**60 Hz**

**OLYMPIAN™**

**D150P1 (3-Phase)**

Materials and specifications are subject to change without notice.

Generator Set Technical Data — 1800 rpm/60 Hz		Standby
Power Rating	kW (kVA)	150 (188)
<b>Lubricating System</b> Type: Full Pressure Oil Filter: Spin-On, Full Flow Oil Cooler: Watercooled Oil Type Required: API CG4 Total Oil Capacity Oil Pan	U.S. gal (L) U.S. gal (L)	5.0 (19) 4.23 (16)
<b>Fuel System</b> Generator Set Fuel Consumption 100% Load 75% Load 50% Load	G/hr (L/hr) G/hr (L/hr) G/hr (L/hr)	11.60 (43.90) 9.00 (34.07) 6.40 (24.21)
<b>Engine Electrical System</b> Voltage/Ground: 12/Negative Battery Charging Generator Ampere Rating	Amps	45
<b>Cooling System</b> Water Pump Type: Centrifugal Radiator System Capacity Incl. Engine Maximum Coolant Static Head Coolant Flow Rate Minimum Temperature to Engine Temperature Rise Across Engine Heat Rejected to Coolant at Rated Power Total Heat Radiated to Room at Rated Power Radiator Fan Load	U.S. gal (L) Ft H <sub>2</sub> O (m H <sub>2</sub> O) U.S. gal/hr (L/hr) °F (°C) °F (°C) Btu/min (kW) Btu/min (kW) Hp (kW)	9.8 (30.7) 32.2 (9.8) 2725 (10 320) 169 (76) 14.4 (8.0) 4363 (83) 2551 (36.2) 10 (7.5)
<b>Air Requirements</b> Combustion Air Flow Maximum Air Cleaner Restriction Radiator Cooling Air (zero restriction) Generator Cooling Air Allowable Air Flow Restriction (After radiator) Cooling Airflow (@ rated speed) Rate with restriction	Cfm (m <sup>3</sup> /min) In H <sub>2</sub> O (kPa) Cfm (m <sup>3</sup> /min) Cfm (m <sup>3</sup> /min) In H <sub>2</sub> O (kPa) Cfm (m <sup>3</sup> /min)	394 (11.2) 20 (3.0) 11,000 (312) 933 (26.4) 0.48 (0.120) 8900 (252)
<b>Exhaust System</b> Maximum Allowable Backpressure Exhaust Flow at Rated kW Exhaust Temperature at Rated kW — Dry Exhaust	In Hg (kPa) Cfm (m <sup>3</sup> /min) °F (°C)	1.8 (6.0) 1102 (31.2) 1229 (665)
<b>Generator Set Noise Rating*</b> (Without Attenuation) at 3 ft (1 m)	dB(A)	97

Generator Technical Data	277/480V	266/460V	127/220V	120/240V 120/208V	347/600V
<b>Motor Starting Capability:</b> (kVA) (30% Voltage Dip)					
Self Excited	420	391	363	330	N/A
PM Excited**	548	511	476	433	548
AREP Excited	548	511	476	433	548
<b>Full Load Efficiencies:</b> Standby	92.9	92.9	92.8	92.5	92.9
<b>Reactances (per unit):</b>					
X <sub>d</sub>	2.91	3.16	3.46	3.87	2.91
X' <sub>d</sub>	0.10	0.11	0.12	0.13	0.10
Reactances shown are applicable to the standby rating.					
X'' <sub>d</sub>	0.058	0.064	0.070	0.078	0.058
X <sub>q</sub>	1.74	1.90	2.08	2.32	1.74
X'' <sub>q</sub>	0.069	0.075	0.082	0.092	0.069
X <sub>2</sub>	0.063	0.069	0.075	0.084	0.063
X <sub>0</sub>	0.005	0.005	0.006	0.007	0.005
<b>Time Constants:</b>	t' <sub>d</sub> 100 ms	t'' <sub>d</sub> 10 ms	t' <sub>do</sub> 2966 ms	t <sub>a</sub> 15 ms	

\* dB(A) levels are for guidance only  
 \*\* With PMG Excited Option AVR12