

APPLICATION RANGE

Trystar Tuff Box Feed Thru 50A 125/250V

STANDARD FEATURES

- NEMA 3R all aluminum construction,
- Heavy-duty stackable legs w/ built-in handles or heavy-duty stackable cage
- Custom powder coat
- Custom UV-printed graphics
- Made in USA

CONFIGURATION

- Input
 - 50A California Style Flanged Inlet (125/250V)
- Output
 - 50A California Style Receptacle (125/250V) for Feed Thru
 - 6 x Duplex GFCI Receptacle (20A, 125V, NEMA 5-20R)
 - 1 x L6-30 Receptacle (30A, 250V, NEMA L6-30R)
 - 6 x 20 Amp 1P Branch Breaker
 - 1 x 30 Amp 2P Branch Breaker

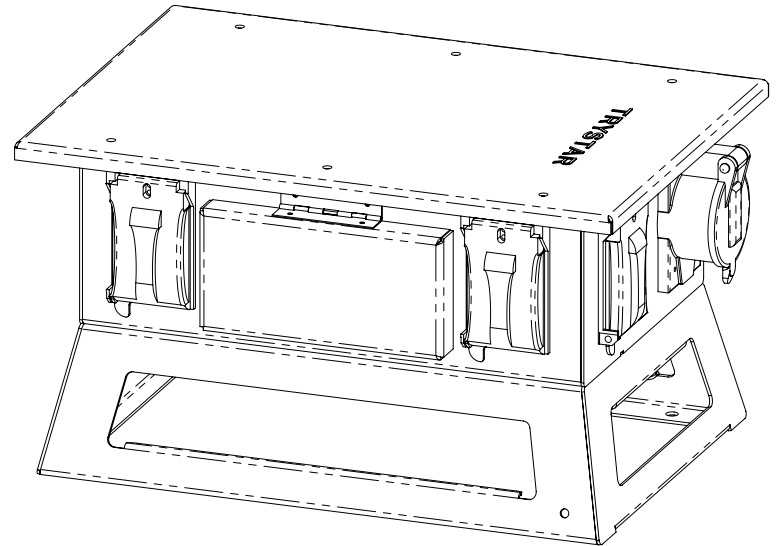

LISTINGS

- UL1640 Listed
- C(ETL) Listed
- UL 50 Listed
- NEMA 3R

*Images are representative, specific final design details may vary

SPIDER BOX

DIMENSIONS AND WEIGHTS



APPROXIMATE WEIGHT: 30 LBS.

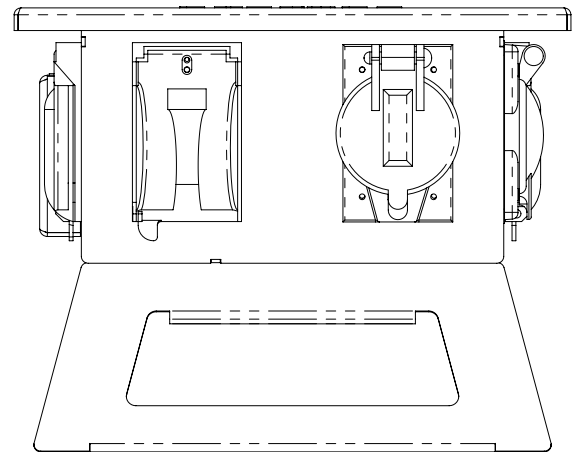
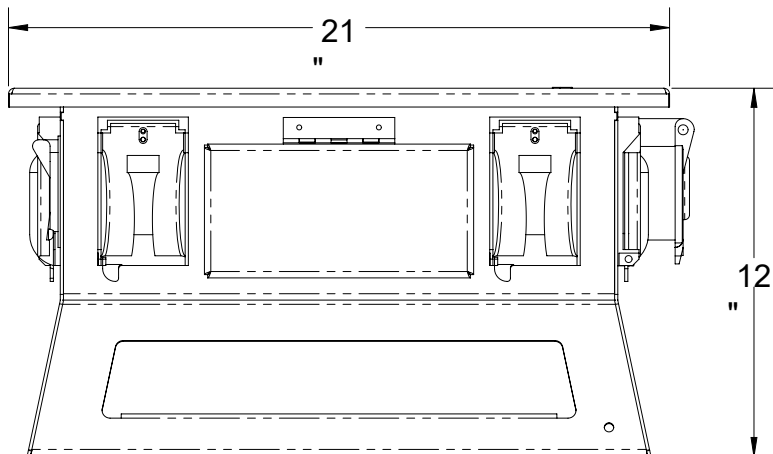
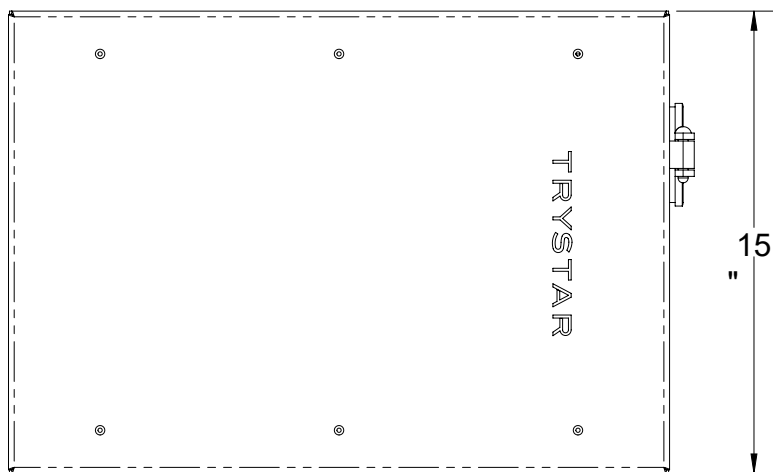

*Dimensions are representative, specific final design details may vary