

## Automatic Transfer Switch



**Kohler Model: KSS-AFNC-0200S**

2 Pole, 3 Wire, Solid Neutral, 200 amp, Kohler Specific Breaker rated Standard automatic transfer switch, Model KSS-AFNC-0200S, rated 240V, 60 Hz complete with all standard equipment and housed in a NEMA Type 3R enclosure.

Qty	Description																										
	ATS KSSB Transfer Switch System																										
3	<p>KSS-AFNC-0200S</p> <p>Includes the following:</p> <table border="0" style="width: 100%;"> <tr> <td style="width: 60%;">Literature Languages</td> <td>English</td> </tr> <tr> <td>Mechanism</td> <td>Specific Breaker</td> </tr> <tr> <td>Transition</td> <td>Standard</td> </tr> <tr> <td>Logic</td> <td>1200</td> </tr> <tr> <td>Voltage</td> <td>240V / 60 Hz</td> </tr> <tr> <td>Poles &amp; Wires</td> <td>2 Pole/3 Wire, Solid Neutral</td> </tr> <tr> <td>Enclosure</td> <td>Nema 3R</td> </tr> <tr> <td>Amps</td> <td>200 Amps</td> </tr> <tr> <td>Connection</td> <td>Standard</td> </tr> <tr> <td>IBC Seismic Certification</td> <td>None</td> </tr> <tr> <td>CSA Certification</td> <td>None</td> </tr> <tr> <td>Miscellaneous Acc., Installed</td> <td>Lockable User Interface Cover</td> </tr> <tr> <td>Warranty</td> <td>1-YR STANDARD</td> </tr> </table>	Literature Languages	English	Mechanism	Specific Breaker	Transition	Standard	Logic	1200	Voltage	240V / 60 Hz	Poles & Wires	2 Pole/3 Wire, Solid Neutral	Enclosure	Nema 3R	Amps	200 Amps	Connection	Standard	IBC Seismic Certification	None	CSA Certification	None	Miscellaneous Acc., Installed	Lockable User Interface Cover	Warranty	1-YR STANDARD
Literature Languages	English																										
Mechanism	Specific Breaker																										
Transition	Standard																										
Logic	1200																										
Voltage	240V / 60 Hz																										
Poles & Wires	2 Pole/3 Wire, Solid Neutral																										
Enclosure	Nema 3R																										
Amps	200 Amps																										
Connection	Standard																										
IBC Seismic Certification	None																										
CSA Certification	None																										
Miscellaneous Acc., Installed	Lockable User Interface Cover																										
Warranty	1-YR STANDARD																										
3	Lit Kit, ATS Production, KSS																										

**KOHLER®**

Spec Sheets

# KOHLER®

**ISO 9001**  
**KOHLER**  
 POWER SYSTEMS  
 NATIONALLY REGISTERED



## Transfer Switch Standard Features

- UL 1008 listed file #E58962 (automatic), #E86894 (non automatic)
- CSA certification available
- IBC seismic certification available
- Available in 2, 3, or 4 pole configurations
- Electrically operated, mechanically held mechanism
- High withstand and close-on ratings
- Design suitable for emergency and standby applications on all classes of load, 100% tungsten rated through 400 amps
- Silver alloy main contacts
- Gold-flashed engine start contacts rated 2 amps @ 30 VDC/250 VAC
- Front-accessible contacts for easy inspection
- Front-replaceable main and arcing contacts (800-1200 amps)
- Reliable, field-proven solenoid mechanism
- Switching mechanisms lubricated for the expected life of the transfer switch
- Internal manual operating handle
- Main shaft auxiliary position-indicating contacts rated 10 amps @ 32 VDC/250 VAC
- NEMA type 1, 12, 3R, 4 and 4X enclosures available
- Standard one-year limited warranty. Extended limited warranties are available.
- Standard-transition operation with either automatic or non-automatic control
- Standard-transition transfer time less than 100 milliseconds (6 cycles @ 60 Hz)
- Double-throw, mechanically interlocked design (break-before-make power contacts)
- Solid, switched, or overlapping (make-before-break) neutral



### Environmental Specifications

Operating Temperature	-20 ° C to 70 ° C (-4 ° F to 158 ° F)
Storage Temperature	-40 ° C to 85 ° C (-40 ° F to 185 ° F)
Humidity	5% to 95% noncondensing

### Input and Output Connection Specifications

Component	Wire Size Range
Main board I/O terminals	#12-24 AWG
I/O module terminals	#14-24 AWG

### Auxiliary Position Indication Contacts (rated 10 Amps @ 32 VDC/250 VAC)

Switch Rating, amps	Number of Contacts Indicating Normal, Emergency
200	2, 2

## Decision-Maker® MPAC 1200 Controller

- LCD display, 4 lines x 20 characters, backlit
- Complete programming and viewing capability at the door using the keypad and LCD display
- LED indicators: Source available, transfer switch position, service required (fault), and "not in auto"
- Programmable voltage and frequency pickup and dropout settings
- Programmable time delays
- Programmable generator exerciser
- Time-based load control
- Two programmable inputs and two programmable outputs
- Up to four I/O extension modules available
- Modbus communication standard
- RS-485 communication standard
- Ethernet communication optional: For more information about Decision-Maker® MPAC 1200 features and functions, see specification sheet G11-127.

## Model KSS-AFNC-0200S, continued

### Weights and Dimensions

See ADV drawings for weights and dimensions. Allow 15% additional weight for packing materials.

UL-Listed Solderless Screw-Type Terminals for External Power Connections			
Range of Wire Sizes, Copper or Aluminum*			
Switch Rating, Amps	Normal, Emergency, and Load	Neutral	Ground
200	(1) #14 AWG to 4/0 AWG Cu only	(3) #14 to 4/0 AWG Cu only	(3) #6 to 3/0AWG
* Use 75 degrees C minimum Cu/Al wire for power connections			

### Withstand and Close-On Ratings (WCR) Ratings Summary

The transfer switch is rated for use on a circuit capable of delivering not more than the RMS symmetrical amperes listed at the specified maximum voltage below, but no greater than the interrupt capacity of the selected circuit breaker or fuse. Circuit breakers and fuses are supplied by the customer.

Withstand and Close-On Ratings (WCR) Standard, Programmed, and Closed-Transition Models										
Switch Rating, Amps	Current Limiting Fuses				Specific Coordinated Breaker			Time-Based Rating		
	Fuse Class	Max Amps	480 VAC	600 VAC	240 VAC	480 VAC	600 VAC	Time sec.	480 V Max.	600 V. Max
200	J	200	200000	NA	200000	85000	14000	0.025	10000	10000

---

## Model KSS-AFNC-0200S, continued

---

### Ratings with Specific Manufacturer's Circuit Breaker

Withstand and close-on ratings (WCR) in RMS symmetrical amperes for specific manufacturers' circuit breakers.

Molded-Case Circuit Breakers					
Switch Rating, Amps	WCR, Amps, RMS	Voltage, Max.	Manufacturer	Type	Max. Size, Amps
200	200000	240	Square D	JR	250
200	125000	240	Square D	JL	250
200	100000	240	Square D	JJ	250
200	65000	240	Square D	JG	250
200	42000	240	Square D	QR, QJ	225
200	25000	240	Square D	JD	250
200	85000	480	Square D	JL, JR	250
200	30000	480	Square D	JG, JJ	250
200	18000	480	Square D	JD	250
200	14000	600	Square D	JD, JG, JJ, JL, JR	250

### Codes and Standards

The ATS meets or exceeds the requirements of the following specifications:

- Underwriters Laboratories UL 1008, Standard for Automatic Transfer Switches for Use in Emergency Standby Systems file #E58962 (automatic), #E86894 (nonautomatic)
- CSA C22.2 No. 178 certification 208-600 VAC available, file #LR58301
- NFPA 70, National Electrical Code
- NFPA 99, Essential Electrical Systems for Health Care Facilities
- NFPA 110, Emergency and Standby Power Systems
- IEEE Standard 446, IEEE Recommended Practice for Emergency and Standby Power Systems for Commercial and Industrial Applications
- NEMA Standards ICS 10-2005, Electromechanical AC Transfer Switch Equipment
- EN61000-4-4 Fast Transient Immunity Severity Level 4
- IEC 609047-6-1, Low Voltage Switchgear and Control Gear; Multifunction Equipment; Automatic Transfer Switching Equipment
- EN61000-4-5 Surge Immunity Class 4 (voltage sensing and programmable inputs only)
- IEC Specifications for EMI/EMC Immunity:
  - o CISPR 11, Radiated Emissions
  - o IEC 1000-4-2, Electrostatic Discharge
  - o IEC 1000-4-3, Radiated Electromagnetic Fields
  - o IEC 1000-4-4, Electrical Fast Transients (Bursts)
  - o IEC 1000-4-5, Surge Voltage
  - o IEC 1000-4-6, Conducted RF Disturbances
  - o IEC 1000-4-8, Magnetic Fields
  - o IEC 1000-4-11, Voltage Dips and Interruptions
- IEEE 472 (ANSI C37.90A) Ring Wave Test
- Seismic certification in accordance with the International Building Code is available. (Accessory kit is required for seismic certification)
  - o IBC 2000, referencing ASCE 7-98 and ICC AC-156
  - o IBC 2003, referencing ASCE 7-02 and ICC AC-156
  - o IBC 2006, referencing ASCE 7-05 and ICC AC-156
  - o IBC 2009, referencing ASCE 7-05 and ICC AC-156
  - o IBC 2012, referencing ASCE 7-10 and ICC AC-156

## Model Designation

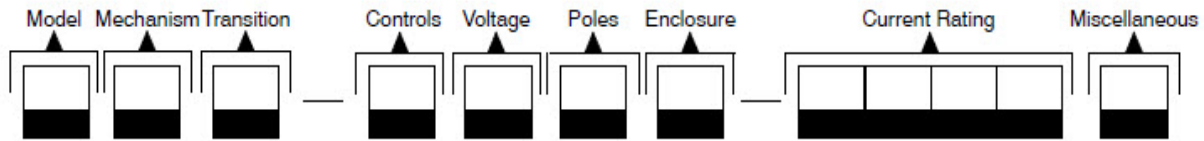

Record the transfer switch model designation in the boxes. The transfer switch model designation defines characteristics and ratings as explained below.

Sample Model Designation: **KSS-AMTA-0400S**

### Model

K: Kohler

### Mechanism

S: Standard (Specific Breaker)

### Transition

S: Standard

### Controller

A: Decision-Maker® MPAC 1200, Automatic

B: Decision-Maker® MPAC 1200, Non-Automatic

### Voltage/Frequency

C: 208 Volts/60 Hz      K: 440 Volts/60 Hz

D: 220 Volts/50 Hz      M: 480 Volts/60 Hz

F: 240 Volts/60 Hz      N: 600 Volts/60 Hz

G: 380 Volts/50 Hz      P: 380 Volts/60 Hz

H: 400 Volts/50 Hz      R: 220 Volts/60 Hz

J: 416 Volts/50 Hz      S: 400 Volts/60 Hz

### Number of Poles/Wires

N: 2 Poles/3 Wires, Solid Neutral

T: 3 Poles/4 Wires, Solid Neutral

V: 4 Poles/4 Wires, Switched Neutral

W: 4 Poles/4 Wires, Overlapping Neutral

### Enclosure

A: NEMA 1

D: NEMA 4

B: NEMA 12

F: NEMA 4X

C: NEMA 3R

G: Open Unit

### Current, Amps

0030                      0200                      0600

0070                      0230                      0800

0104                      0260                      1000

0150                      0400                      1200

### Connections

S: Standard

**Note:** Some selections are not available for every model. Contact your Kohler distributor for availability.



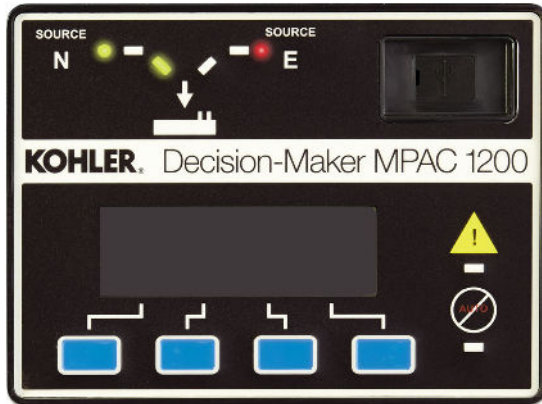

Model KCS with Decision-Maker® MPAC 1200 Controller

### Decision-Maker® MPAC 1200 Controller Standard Features

- Microprocessor-based controller
- Environmentally sealed user interface
- LCD display, 4 lines x 20 characters, backlit
- Dynamic function keypad with tactile feedback pushbuttons allows complete programming and viewing capability at the door
- LED indicators: Source available, transfer switch position, service required (fault), and not in auto
- Broadrange voltage sensing (208- 600 VAC) on all phases
- Phase-to-phase sensing and monitoring with 0.5% accuracy on both sources
- Line-to-neutral monitoring
- Frequency sensing with 0.5% accuracy on both sources
- Anti-single phasing protection
- Phase rotation sensing for three-phase systems
- Real-time clock with automatic adjust for daylight saving time and leap year
- Run time clock and operation counter
- Time-stamped event log
- Fail-safe transfer for loaded test and exercise functions
- DIP switches: password disable and maintenance
- Isolated RS-485 ports for Modbus connections (9.6, 19.2, and 57.6 kbps)
- Modbus® RTU protocol (Modbus register map available)
- USB port. Connect a personal computer and use Kohler® SiteTech™ software to view events and adjust settings. \*
- Available in automatic and non-automatic versions; see supervised transfer control switch on page 5

### Programmable Features

- Programming and monitoring methods:
  - Monitoring and password-protected programming at the door using the keypad and display
  - Program using a PC with Kohler® SiteTech™ software (available to Kohler-authorized distributors and dealers)
- Over/undervoltage for all phases of the normal and emergency sources
- Over/underfrequency for the emergency source
- Adjustable time delays
- Load/no load/auto-load test and load/no-load exercise functions
- Programmable inputs and outputs
- Load bank control for exercise or test
- Time-based load control, nine individual time delays for selected loads
- In-phase monitor (3-phase only)
- Password protection, three security levels
- See pages 2 and 3 for additional programmable features

\* SiteTech software is available to Kohler-authorized distributors and dealers.

Modbus is a registered trademark of Schneider Electric.

### Applicable Models

Model	Description
KCS	Standard-Transition Any Breaker ATS ‡
KCP	Programmed-Transition Any Breaker ATS ‡
KCC	Closed-Transition Any Breaker ATS §
KSS	Standard-Transition Specific Breaker ATS ‡
‡ Available with automatic or non-automatic controller	
§ Available with automatic controller only	

# Decision-Maker® MPAC 1200 Controller Features

## User Interface LED Indicators

- Contactor position: source N and source E
- Source available: source N and source E
- Service required (fault indication)
- Not in automatic mode

## LCD Display

- System status
- Line-to-line voltage
- Line-to-neutral voltage
- Active time delays
- Source frequency
- Preferred source selection
- System settings
- Common alarms
- Load current, each phase (current sensing kit required)
- Inputs and outputs
- Faults
- Time/date
- Address
- Event history
- Maintenance records
- Exerciser schedule
- Exerciser mode
- Time remaining on active exercise

## Dynamic Function Tactile Keypad Operations

- Scroll up/down/forward/back
- Increase/decrease/save settings
- End time delay
- Start/end test or exercise
- Reset fault
- Lamp test

## DIP Switches

- Maintenance mode
- Password disable

## Event History

- View time and date-stamped events on the display or on a personal computer equipped with Kohler® SiteTech™ software. \*
- Download complete event history files using Kohler SiteTech software and a PC connected to the USB port. \*

## Main Logic Board Inputs and Outputs

- Two (2) programmable inputs
- Two (2) programmable outputs

## Communications

- Optional Ethernet communications with RJ45 connector for 10/100 Ethernet connection
- Isolated RS-485 ports for Modbus communications
- Modbus® RTU and Modbus® TCP/IP protocols (Modbus® register map available)
- USB Port. Use SiteTech software to upload or download files and adjust transfer switch settings \*
  - Application software
  - Event history files
  - Language files
  - Parameter settings
  - Usage reports
  - Feature configuration

## Programmable Features

- System voltage, 208- 600 VAC †
- System frequency, 50/60 Hz †
- Single/three-phase operation †
- Standard/programmed/closed-transition operation †
- Preferred source selection allows the normal or emergency source to be used when both sources are available (alarm module required)
- Phase rotation: ABC/BAC/none selection with error detection
- Undervoltage and undervoltage pickup and dropout settings, both sources
- Overfrequency and underfrequency pickup and dropout settings, Emergency source
- Voltage unbalance, enable/disable
- In-phase monitor: enable/disable and phase angle
- Transfer commit/no commit
- Passwords, system and test
- Time, date, automatic daylight saving time enable/disable
- Time delays (see table)
- Exerciser: calendar mode, loaded/unloaded up to 21 events
- Test: loaded/unloaded/auto load (1- 60 minutes)
- Remote test: loaded/unloaded
- Automatic override on generator failure (loaded test and exercise)
- Peak shave delay enable/disable
- Current monitoring (current sensing kit required)
- Load control pre/post-transfer delays, 9 individual time delays for selected loads
- Resettable historical data

\* SiteTech software is available to Kohler-authorized distributors and dealers.

† System parameters are factory-set per order.

Modbus is a registered trademark of Schneider Electric.

## Decision-Maker® MPAC 1200 Controller Features, Continued

### Programmable Inputs

- Forced transfer to OFF (programmed-transition models only; requires load shed accessory)
- Inhibit transfer
- Low battery voltage (external battery supply module required)
- Peak shave/area protection input
- Remote common fault
- Remote test
- Remote end time delay
- Remotely monitored inputs, four (4) available

### Programmable Outputs

- Alarm silenced
- Audible alarm
- Chicago alarm control
- Common alarm events
- Contactor position
- Exercise active
- Failure to acquire standby source
- Failure to transfer
- Generator engine start, source E
- I/O module faults
- In-phase monitor synch
- Load bank control
- Load control active (pre/post transfer delay, up to 9 outputs)
- Loss of phase fault, source N and E
- Low battery fault (external battery supply module required)
- Maintenance mode
- Non-emergency transfer
- Not in automatic mode
- Over/undervoltage faults, source N and E
- Peak shave/area protection active
- Phase rotation error, source N and E
- Preferred source supplying load
- Software-controlled relay outputs (four maximum)
- Source available, preferred and standby
- Standby source supplying load
- Test active
- Transfer switch auxiliary contact fault
- Transfer switch auxiliary contact open
- Voltage unbalance, source N and E

Voltage and Frequency Sensing		
Parameter	Default	Adjustment Range
Undervoltage dropout	90% of pickup	75% - 98%
Undervoltage pickup	90% of nominal	85% - 100%
Overvoltage dropout *	115% of nominal*	106% - 135%
Overvoltage pickup	95% of dropout	95% - 100%
Unbalance enable	Disable	Enable/Disable
Unbalance dropout	20%	5% - 20%
Unbalance pickup	10%	3% - 18%
Voltage dropout time	0.5 sec.	0.1 - 9.9 sec.
Underfrequency dropout †	99% of pickup	95% - 99%
Underfrequency pickup †	90% of nominal	80% - 95%
Overfrequency dropout †	101% of pickup	101% - 115%
Overfrequency pickup †	110% of nominal	105% - 120%
Frequency dropout time †	3 sec.	0.1 - 15 sec.
* 690 volts, maximum. Default = 110% for 600 volt applications.		
† Emergency source only		

Adjustable Time Delays		
Time Delay	Default	Adjustment Range
Engine start	3 sec.	0 - 6 sec. †
Engine cooldown	5 min.	0 - 60 min.
Fail to acquire standby source	1 min.	
Transfer, preferred to standby	3 sec.	
Transfer, standby to preferred	15 min.	
Transfer, off to standby	1 sec.	1 sec. - 60 min.
Transfer, off to preferred	1 sec.	
Fail to synchronize	60 sec.	10 sec - 15 min.
Auto load test termination after transfer	1 sec.	1 sec. - 60 min.
<b>Load Control Time Delays:</b>		
Pretransfer to preferred	0 sec.	0 - 60 min.
Post-transfer to preferred	0 sec.	
Pretransfer to standby	0 sec.	
Post-transfer to standby	0 sec.	
<b>Note:</b> Time delays are adjustable in 1 second increments, except as noted.		
† Engine start time delay can be extended to 60 minutes with an External Battery Supply Module Kit.		

**KOHLER®**

# Dimensional Drawings

SECURITY COVER  
OPTIONAL ON NEMA 1  
REQUIRED FOR NEMA 3R

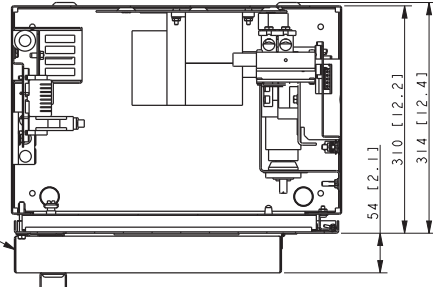

SECTION C-C

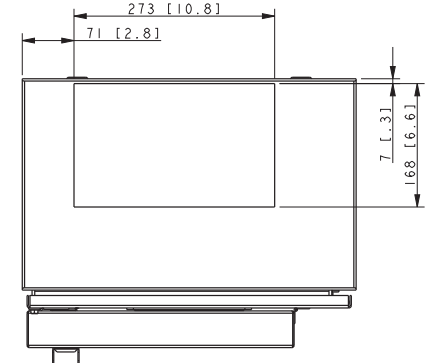

RECOMMENDED ENTRANCE AREA  
TOP & BOTTOM

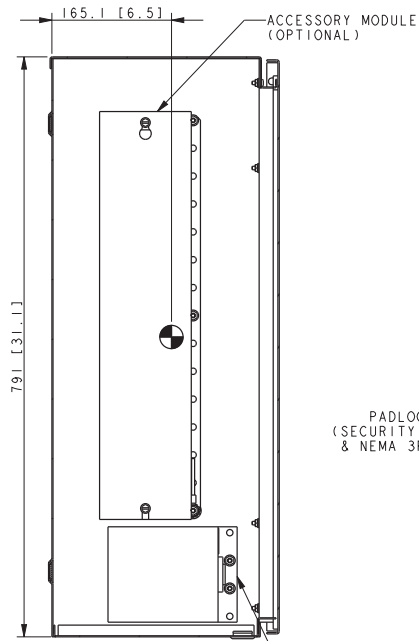

SECTION A-A

PADLOCK HASP  
(SECURITY OPTION  
& NEMA 3R ONLY)

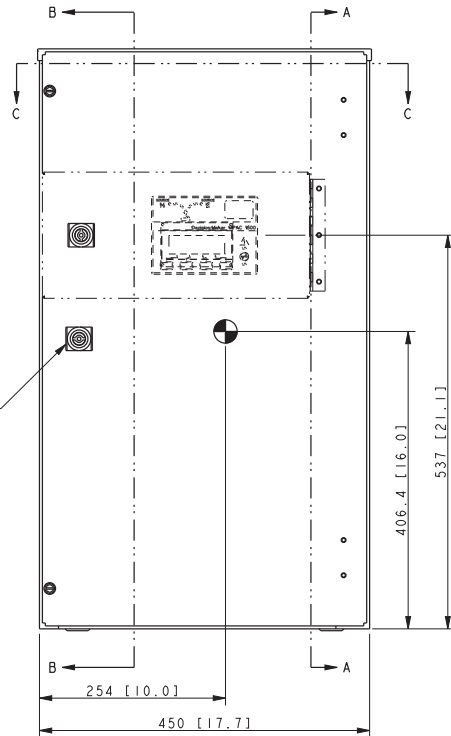

SECTION B-B

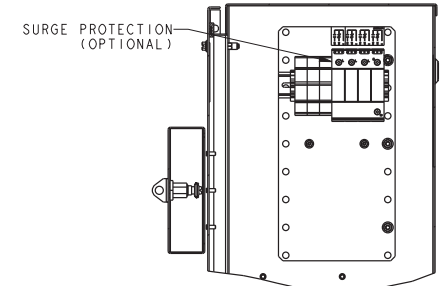
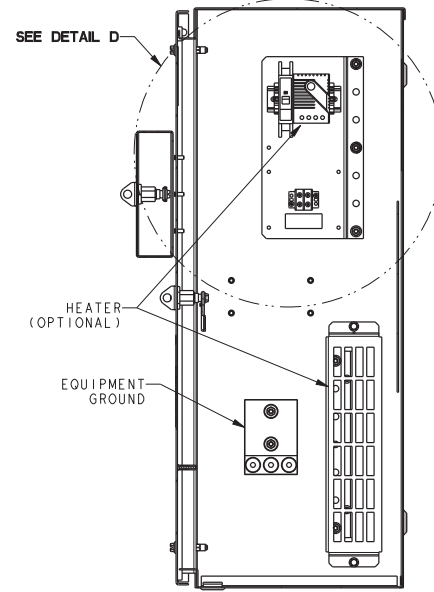

DETAIL D  
OF SECTION B-B

NOTE:  
DUE TO THE SPACE LIMITATIONS,  
SURGE PROTECTION OR HEATER  
MAY BE ORDERED, BUT NOT BOTH.

DIMENSIONS IN [ ] ARE INCHES.

FINISH: ANSI 49 GRAY.

REFER TO OPERATOR'S MANUAL PRIOR TO  
INSTALLATION AND OPERATION OF UNIT.

FOR SEISMIC CERTIFIED UNITS, REFER TO  
ADV-7456 AND INSTALLATION INSTRUCTIONS.

NOTE:  
ALLOW FOR MINIMUM DOOR  
SWING CLEARANCE OF 508 [20.0]  
IN FRONT OF CABINET.

SEE ADV-8565 FOR FULL MODEL CODE DEFINITION

STYLE	MECHANISM	TRANSITION	MPAC LOGIC	VOLTS	POLES	NEUTRAL	ENCLOSURE	AMPS	CONNECTION
KCS	STANDARD	STANDARD	1200, 1500	208-600	2, 3, 4	SOLID, SW	1, 3R	30, 70, 104, 150	STANDARD
KCS	STANDARD	STANDARD	1200, 1500	208-480	2, 3, 4	SOLID, SW	1, 3R	200	STANDARD
KSS	SPECIFIC BREAKER	STANDARD	1200	208-600	2, 3, 4	SOLID, SW	1, 3R	30, 70, 104, 150	STANDARD
KSS	SPECIFIC BREAKER	STANDARD	1200	208-480	2, 3, 4	SOLID, SW	1, 3R	200	STANDARD

REV	DATE	REVISION	BY	UNLESS OTHERWISE SPECIFIED - 21 DIMENSIONS ARE IN MILLIMETERS TOLERANCES ARE:
-	8-15-13	NEW DRAWING [CT54441]	BTW	
A	12-11-20	(C-7) FIXED ASSEMBLY; (A-8) ADDED 2 KSS		
		ROWS: (A-5) REMOVED OVL P FROM KCS ROWS; ADDED SW TO KCS ROW; (B-5, 6, 8) ADDED CG; [CT208031]		
			ZHK	
APPROVALS		DATE	TITLE	
DRWN	BTW	8-15-13	DIMENSION PRINT	
CHECKED	BTW	8-15-13	SCALE	CAD NO.
APPROVED	MTL	8-15-13	SCALE	SHEET 1 of 2
			ADV-8566	

**KOHLER CO. METRIC PRO-E**  
POWER SYSTEMS, KOHLER, WI 53044 U.S.A.  
THIS DRAWING IN DESIGN AND DETAIL IS KOHLER CO.  
PROPERTY AND MUST NOT BE USED EXCEPT IN  
CONNECTION WITH KOHLER CO. WORK. ALL RIGHTS OF  
DESIGN OR INVENTION ARE RESERVED.

**DIMENSION PRINT**

SCALE: [ ]

CAD NO. [ ]

SHEET 1 of 2

ADV-8566

D

8 7 6 5 4 3 2 1

**SEISMIC MOUNTING NOTE:**  
 FOR SEISMIC CERTIFIED UNITS,  
 MOUNT WITH THE FOLLOWING HARDWARE:  
 Ø9.53 [.375] BOLT (4)  
 Ø25.4 [1.00] x 2.1 [.083] THICK WASHER (4)  
 HARDWARE TO COMPLY WITH SPECIFICATIONS  
 ON ADV-7456.

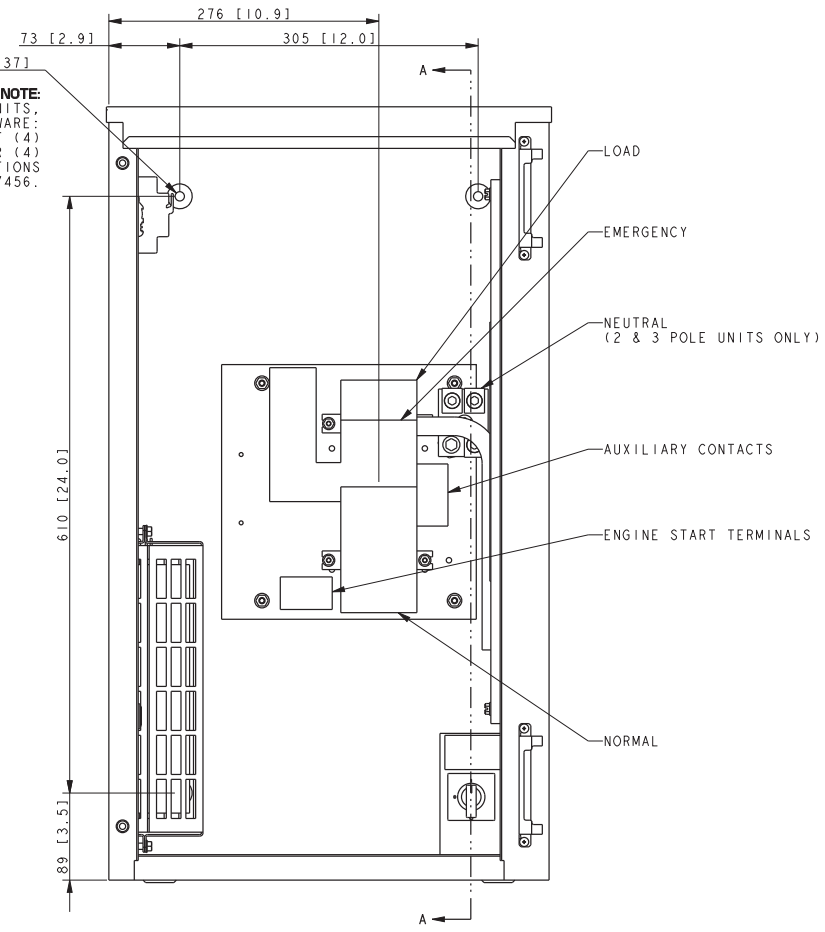

**FRONT VIEW**  
 WITH DOOR REMOVED

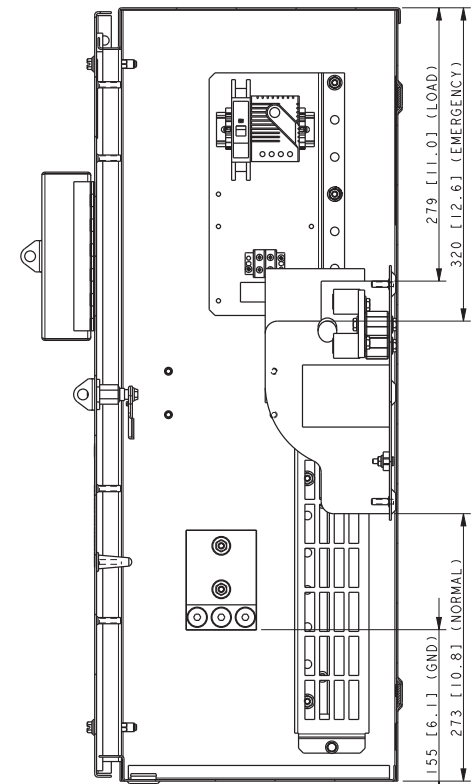

**SECTION A-A**

SCREW TYPE TERMINALS FOR EXTERNAL POWER CONNECTION			
SWITCH RATING (AMPS)	RANGE AL/CU OF WIRE SIZES		
	CONTACTOR PER PHASE	NEUTRAL	GROUND
30-150	(1) #14 TO 4/0	(3) #14 TO 4/0	
200	(1) #14 TO 4/0 (Cu ONLY)	(3) #14 TO 4/0 (Cu ONLY)	(3) #6 TO 3/0

WEIGHTS KG (LBS)		
2 POLE	3 POLE	4 POLE
28 (62)	30 (65)	31 (68)

REV	DATE	REVISION	BY	UNLESS OTHERWISE SPECIFIED - 1) DIMENSIONS ARE IN MILLIMETERS 2) TOLERANCES ARE:
-	8-15-13	NEW DRAWING [CT54441]	BTW	
A	12-11-20	(A-7) UPDATED TABLE; (B-4) UPDATED NOTE [CT208031]	ZHK	

POWER SYSTEMS - KOHLER, WI 53044 U.S.A. THIS DRAWING IN DESIGN AND DETAIL IS KOHLER CO. PROPERTY AND MUST NOT BE USED EXCEPT IN CONNECTION WITH KOHLER CO. WORK. ALL RIGHTS OF DESIGN OR INVENTION ARE RESERVED.			
TITLE <b>DIMENSION PRINT</b>		SCALE NONE (CAD NO.) SHEET 2 of 2 PART NO. <b>ADV-8566</b>	
APPROVALS DRAWN BTW 8-15-13 CHECKED BTW 8-15-13 APPROVED MTL 8-15-13	DATE 8-15-13	MAX. DIMENSION 	

8 7 6 5 4 3 2 1

**KOHLER®**

# Wiring Schematics

REV	DATE	REVISION	BY
-	12-9-20	NEW DRAWING [CT207899]	SMH

- LEGENDS**
- BID - BYPASS/ISOLATION DISPLAY
  - BP - BYPASS SWITCH
  - CR(Ø) - BRIDGE RECTIFIER
  - IP(Ø) - ISOLATION PLUG ASSEMBLY
  - IS - ISOLATION (TRANSFER SWITCH CARRIAGE POSITION)
  - J(Ø) - CONNECTOR (JACK)
  - K(Ø) - RELAY
  - LCD - LIQUID CRYSTAL DISPLAY
  - F(Ø) - CONNECTOR (PLUG)
  - SL(Ø) - SOLENOID LOCK RELAY
  - SW1 - DIP SWITCH
  - TB1 - MPAC PROGRAMMABLE INPUT/OUTPUT TERMINAL BLOCK
  - TB1-(Ø) - TRANSFER SWITCH TERMINAL BLOCK
  - TB2 - MPAC MODBUS TERMINAL BLOCK
  - TBF - FIELD CONNECTION TERMINAL BLOCK
  - TS - TRANSFER SWITCH

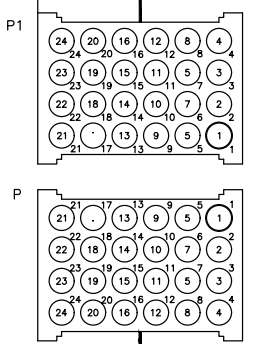
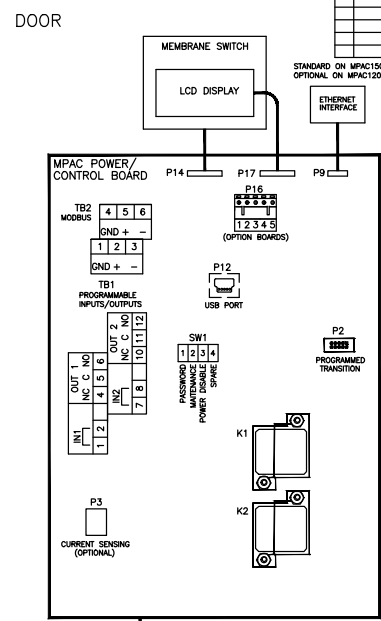

**P CONNECTIONS (CONTACTOR TO MAIN LOGIC BOARD)**

PIN #1	1	2	3	4	5	6	7	8	9	10	11	12											
(TS-8)	1	(TS-A)	2	(TS-6)	3	(TS-3)	4	(TS-B)	5	(TS-5)	6	(TS-4)	7	(TB/TS-14)	8	(TB/TS-15)	9	(TS-17)	10	(TS-2)	11	(TS-1)	12
(TS-18)	13	(TS-18)	14	(TS-70)	15	(TS-72)	16	N/C	17	(TS-19)	18	(TS-20)	19	(TS-21)	20	(TS-22)	21	(TS-NN)	22	(TS-EN)	23	(TS-LN)	24

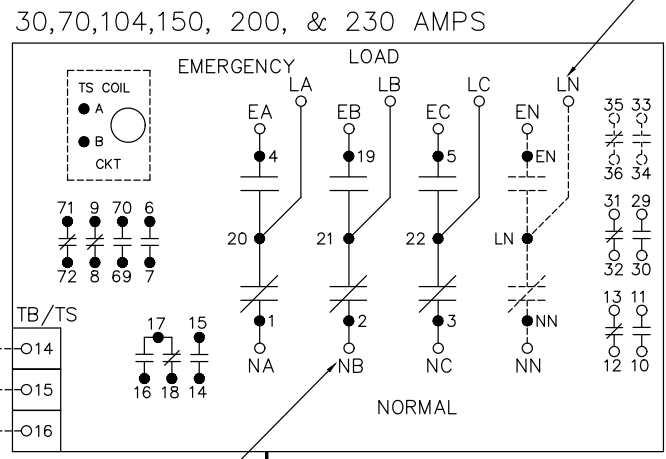

ENGINE START CONTACTS TO SHEET 3

SINGLE PHASE OMITS B PHASE

OPTIONAL SWITCHING NEUTRAL

OPTIONAL TS AUXILIARY CONTACTS ACCESSORY

TS AUXILIARY CONTACTS FEATURE

MODEL KSS  
SPECIFIC MECHANISM  
STANDARD TRANSITION  
30-230A, 1 & 3 PHASE

<small>THIS DRAWING IS THE PROPERTY OF KOHLER. IT IS TO BE USED ONLY FOR THE PROJECT AND SITE SPECIFICALLY IDENTIFIED HEREON. IT IS NOT TO BE REPRODUCED OR TRANSMITTED IN ANY FORM OR BY ANY MEANS, ELECTRONIC OR MECHANICAL, INCLUDING PHOTOCOPYING, RECORDING, OR BY ANY INFORMATION STORAGE AND RETRIEVAL SYSTEM, WITHOUT THE WRITTEN PERMISSION OF KOHLER.</small>		<b>KOHLER</b> KOHLER, WI 53044 THE KOHLER COMPANY ALL RIGHTS RESERVED
APPROVALS SMH DJY DUY	DATE 10-30-20 10-30-20 10-30-20	DRAWING NO. <b>DIAGRAM, ATS, KSS 30-230A D FRAME</b>
REVISED DATE 10-30-20	REVISED BY SMH	DRAWING NO. <b>GM115521</b>



REV	DATE	REVISION	BY
-	12-9-20	NEW DRAWING [1207889]	SMH

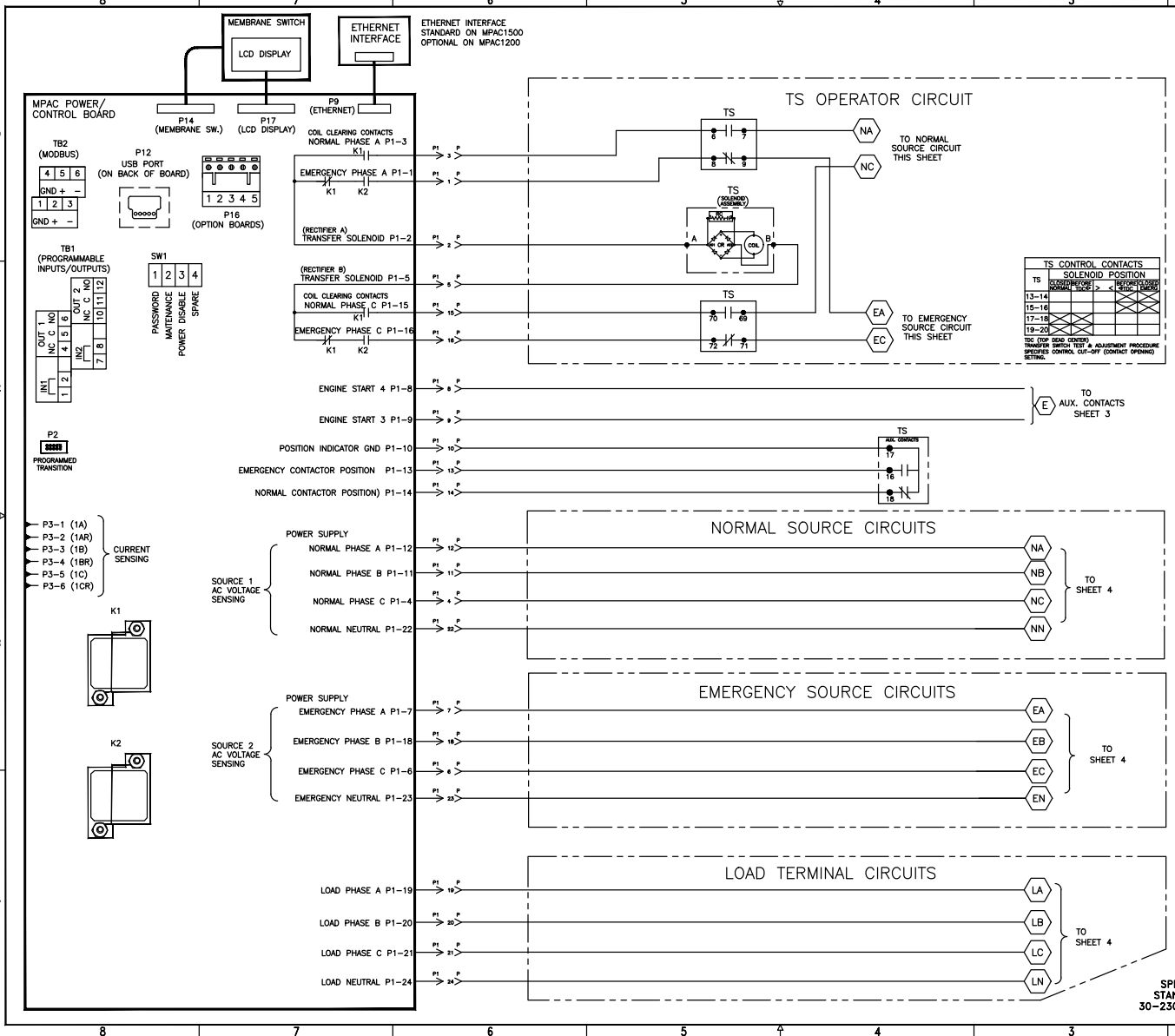

MODEL KSS  
SPECIFIC MECHANISM  
STANDARD TRANSITION  
30-230A, 1 & 3 PHASE

APPROVALS	DATE
SMH	10-30-20
DJY	10-30-20
DJY	10-30-20

DIAGRAM, ATS, KSS  
30-230A D FRAME

GM 115521

REV	DATE	REVISION	BY
-	12-9-20	NEW DRAWING [1207889]	SMH

### MAIN POWER POLES

### AUXILIARY CONTACTS

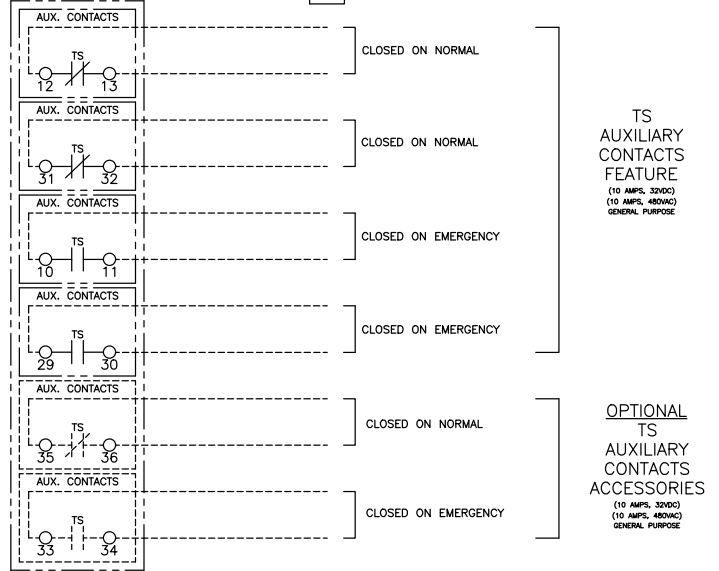
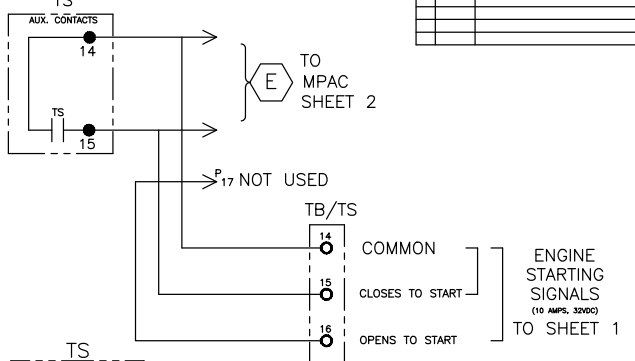
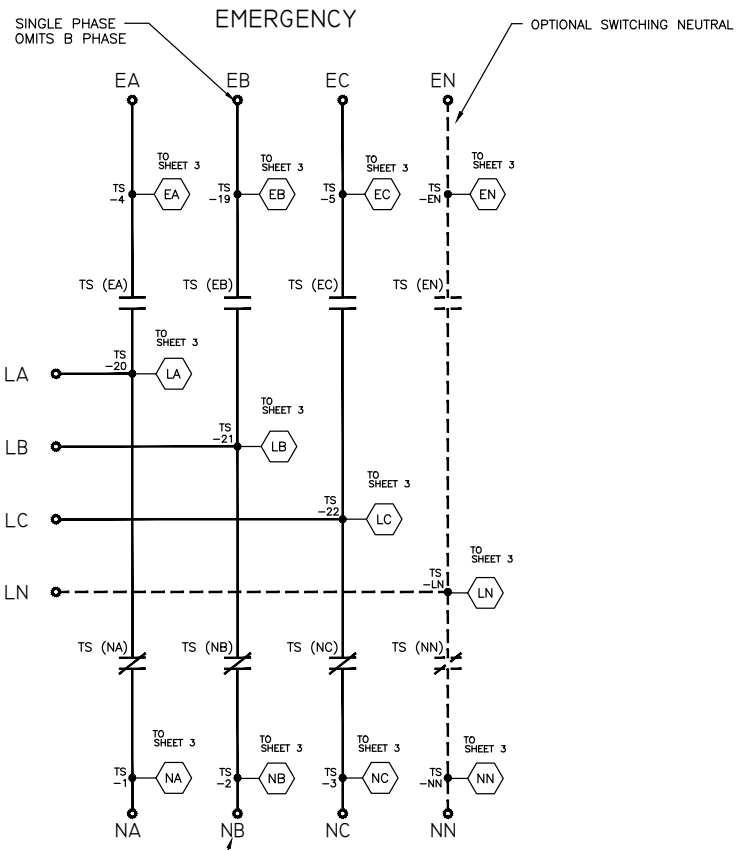

- GENERAL NOTES**
1. SWITCH SHOWN DE-ENERGIZED AND CONNECTED TO THE NORMAL SOURCE.
  2. ALL WIRING IS #16 AWG, TINNED, STRANDED COPPER UNLESS OTHERWISE INDICATED.

MODEL KSS  
 SPECIFIC MECHANISM  
 STANDARD TRANSITION  
 30-230A, 1 & 3 PHASE

APPROVALS	DATE	REVISION
SMH	10-30-20	1
DJY	10-30-20	2
DJY	10-30-20	3

DIAGRAM, ATS, KSS  
 30-230A D FRAME  
 GM115521

**KOHLER®**

**Warranty**

# Transfer Switch One-Year Limited Warranty

Your Kohler product has been manufactured and inspected with care by experienced craftsmen. If you are the original end user, Kohler Co. warrants, for the period indicated below, each product to be free from defects in materials and workmanship. In the event of a defect in materials or workmanship, Kohler Co. will repair, replace, or make appropriate adjustment at Kohler Co.'s option if the product, upon Kohler Co.'s inspection, is found to be properly installed, maintained, and operated in accordance with Kohler Co.'s instruction manuals. A Kohler distributor, dealer, or authorized service representative must perform startup.

## Kohler Product

Transfer switch and factory-supplied transfer switch accessories

Transfer switch main contacts

## Warranty Coverage

One (1) year from the registered startup date. In any event, the warranty period will expire not later than thirty (30) months from the date of shipment from Kohler Co.'s factory.

Ten (10) years from the registered startup date. In any event, the warranty period will expire not later than eleven (11) years and six (6) months from the date of shipment from Kohler Co.'s factory.

The following will **not** be covered by the warranty:

1. Normal wear, periodic service, and routine adjustments.
2. Damage, including but not limited to damage caused by accidents, improper installation or handling, faulty repairs not performed by an authorized Kohler service representative, improper storage, or acts of God.
3. Damage caused by:
  - a. Operation above or below rated capacity, voltage, or frequency.
  - b. Modifications.
  - c. Installation contrary to published specifications and codes.
4. Damage caused by negligent maintenance such as:
  - a. Failure to provide a clean, dry environment.
  - b. Failure to perform recommended exercising.
  - c. Failure to perform scheduled maintenance as prescribed in supplied manuals.
  - d. Use of parts and/or procedures other than factory-supplied or -approved replacement parts and/or procedures.
5. Non-Kohler replacement parts. Replacement of a failed Kohler part with a non-Kohler part voids the warranty on that part.
6. Original installation charges and startup costs.
7. Additional expenses for repair after normal business hours, i.e. overtime or holiday labor rates.
8. Rental of equipment during performance of warranty repairs.
9. Removal and replacement of non-Kohler-supplied options and equipment.
10. Non-Kohler-authorized repair shop labor without prior approval from Kohler Co. Warranty Department.
11. Expenses incurred investigating performance complaints unless the problem is caused by defective Kohler materials or workmanship.
12. Maintenance items such as fuses, lamps, and adjustments.
13. Labor and travel charges after the first year of the transfer switch main contacts warranty period.
14. Travel time and mileage exceeding 300 miles round trip.

To obtain warranty service, call 1-800-544-2444 for your nearest authorized Kohler service representative or write Kohler Co., Kohler Power Systems Service Department, MS072, Kohler, WI 53044 USA.

**KOHLER CO. SHALL NOT BE LIABLE FOR SPECIAL, INCIDENTAL, AND/OR CONSEQUENTIAL DAMAGES OF ANY KIND including, but not limited to, incidental and/or consequential labor costs, installation charges, telephone charges, or transportation charges in connection with the replacement or repair of defective parts.**

This is our exclusive written warranty. We make no other express warranty nor is anyone authorized to make any on our behalf.

**ANY IMPLIED OR STATUTORY WARRANTY, INCLUDING ANY WARRANTY OF MERCHANTABILITY OR FITNESS FOR A PARTICULAR PURPOSE, IS EXPRESSLY LIMITED TO THE DURATION OF THIS WARRANTY. Some states do not allow limitations on how long an implied warranty lasts, or the exclusion or limitation of incidental and/or consequential damages, so the above limitation or exclusion may not apply to you.**

This warranty gives you specific legal rights, and you may also have other rights which vary from state to state.

# KOHLER®

KOHLER CO. Kohler, Wisconsin 53044  
Phone 920-457-4441, Fax 920-459-1646  
For the nearest sales/service outlet in the  
US and Canada, phone 1-800-544-2444  
KOHLERPower.com

TP-5373 4/15f

**KOHLER®**

Certification

# Kohler Automatic Transfer Switch Test Program

## Non-Bypass Models

Testing is an integral part of quality assurance. In keeping with our uncompromising commitment to quality, safety, and reliability, every Kohler Automatic Transfer Switch (ATS) undergoes an extensive series of performance and production testing.

### Performance Testing

All Kohler ATSs are UL1008 listed, which includes the following performance tests:

- General – Normal Operation
- Overvoltage
- Undervoltage
- Overload
- Temperature Rise
- Endurance
- Dielectric Voltage – Withstand
- Short Circuit Withstand
- Short Circuit Close- On
- Dielectric Voltage – Withstand (repeated)
- Strength of insulating base and support

### EMC/EMI Immunity Verification

Controls and printed circuit board assemblies are evaluated to IEC and IEEE tests, including:

- EN61000-4-4 Fast Transient Immunity Severity Level 4
- EN61000-4-5 Surge Immunity Class 4 (voltage sensing and programmable inputs only)
- IEC Specifications for EMI/EMC Immunity:
  - CISPR 11, Radiated Emissions
  - IEC 1000-4-2, Electrostatic Discharge
  - IEC 1000-4-3, Radiated Electromagnetic Fields
  - IEC 1000-4-4, Electrical Fast Transients (Bursts)
  - IEC 1000-4-5, Surge Voltage
  - IEC 1000-4-6, Conducted RF Disturbances
  - IEC 1000-4-8, Magnetic Fields
  - IEC 1000-4-11, Voltage Dips and Interruptions
- IEEE 472 (ANSI C37.90A) Ring Wave Test

### Production Testing

Every Kohler ATS is fully tested prior to leaving the factory. Visual inspections are also performed by the mechanism manufacturer as well as Kohler personnel during assembly and final test. Production testing includes the following:

- Electrical operation testing on all ATSs
- Verification of controller communication
- Verification of controller settings
- Voltage calibration
- Automatic transfer switch operation when Normal source is lost
  - Verify engine start signal
  - Verify transfer to Emergency position when Emergency source is available
- Automatic Transfer switch operation when Normal source returns
  - Verify transfer to Normal position
  - Verify engine start signal is removed

### CSA Certification

CSA Certification is also available upon request. CSA certification includes the following additional test:

- Dielectric test at 1000V plus twice the maximum rated voltage

### Options Testing

The operation of all installed options is verified. Tested options include:

- Input/Output Modules
- Supervised Transfer Control Switch
- Preferred Source Switch
- Load Shed, Normal and Emergency
- Line-to- Neutral Monitoring
- Digital Meter setup and operation

Kohler offers other testing at the customer's request at an additional charge. These optional tests include customized load testing for specific application, witness testing, and contact resistance testing. A certified test report is also available at an additional charge.

# KOHLER®

KOHLER CO., Kohler, Wisconsin 53044  
Phone 920-457-4441, Fax 920-459-1646  
For the nearest sales/service outlet in the  
US and Canada, phone 1-800-544-2444  
KOHLERPower.com