

Generator

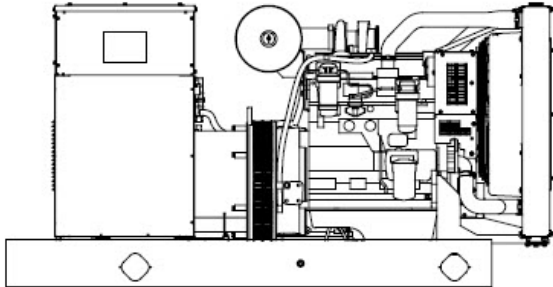

Kohler Model: 100REOZJF

This diesel generator set equipped with a 4R9X alternator operating at 120/208 volts is rated for 100 kW/125 kVA. Output amperage: 347

Standard Features:

- Kohler Co. provides one-source responsibility for the generating system and accessories.
- Approved for use with certified renewable Hydrotreated Vegetable Oil (HVO) / Renewable Diesel (RD) fuels compliant with EN15940/ASTM D975.
- The generator set and its components are prototype-tested, factory-built, and production-tested.
- The 60 Hz generator set offers a UL 2200 listing.
- The generator set accepts rated load in one step.
- The 60 Hz generator set meets NFPA 110, Level 1, when equipped with the necessary accessories and installed per NFPA standards.
- A one-year limited warranty covers all systems and components. Two-, five-, and ten-year extended warranties are also available.
- Tier 3 EPA-certified for Stationary Emergency Applications
- Alternator Protection
- Battery Rack and Cables
- Customer Connection (standard with Decision-Maker 6000 controller only)
- Local Emergency Stop Switch
- Oil Drain Extension
- Operation and Installation Literature

Other Features:

- Kohler designed controller for guaranteed system integration and remote communication.
- The low coolant level shutdown prevents overheating (standard on radiator models only). Integral vibration isolation eliminates the need for under-unit vibration spring isolators.
- Mount up to three circuit breakers to allow circuit protection of selected priority loads.

Alternator Features:

- The unique Fast-Response X excitation system delivers excellent voltage response and short circuit capability using a rare-earth, permanent magnet (PM)-excited alternator.
- The brushless, rotating-field alternator has broad range reconnectability.

Qty

Description

100REOZJF Generator System

4

100REOZJF Generator Set

Includes the following:

Literature Languages	English
Approvals and Listings	UL2200 Listing
Engine	100REOZJF, 12V, 60Hz
Nameplate Rating	Standby 130C Rise
Voltage	60Hz, 120/208V, Wye, 3Ph, 4W
Alternator	4R9X
Cooling System	Unit Mounted Radiator, 50C
Skid and Mounting	Skid/Tank
Air Intake	Standard Duty
Controller	APM603
Enclosure Type	Sound
Enclosure Material	Steel
Enclosure Silencer	Internal Silencer
Fuel Tank Type	State
Fuel Runtime (Approx.)	24 Hours
Subbase Fuel Tank Capacity	215 Gallons
Starting Aids, Installed	1500W,120V
Electrical Accy.,Installed	Battery, 1/12V, Wet
Electrical Accy.,Installed	Battery Charger, 10A
Electrical Accy.,Installed	Run Relay
Electrical Accy.,Installed	15 Relay I/O Board
Rating, LCB 1	100% Rated
Amps, LCB 1	400
Trip Type, LCB 1	Electronic, LSI
Interrupt Rating LCB 1	35kA at 480V
Fuel Lines, Installed	Flexible Fuel Lines
Miscellaneous Accy.,Installed	Air Cleaner Restriction Ind.
Miscellaneous Accy.,Installed	Coolant in Genset
Warranty	Standard
Testing, Additional	Power Factor Test,0.8,3Ph Only

4

Lit Kit, General Maint, 100REOZJF

KOHLER®

Spec Sheets

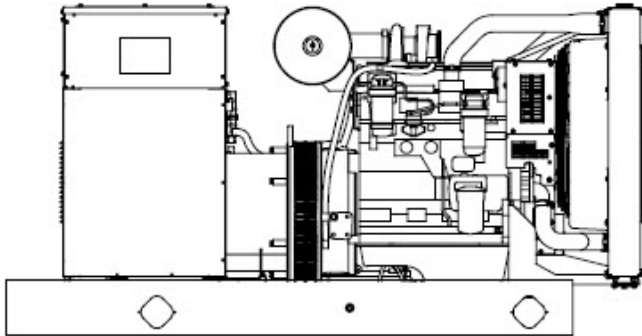

Standard Features

- Kohler Co. provides one-source responsibility for the generating system and accessories.
- Approved for use with certified renewable Hydrotreated Vegetable Oil (HVO) / Renewable Diesel (RD) fuels compliant with EN15940/ASTM D975.
- The generator set and its components are prototype-tested, factory-built, and production-tested.
- The 60 Hz generator set offers a UL 2200 listing.
- The generator set accepts rated load in one step.
- The 60 Hz generator set meets NFPA 110, Level 1, when equipped with the necessary accessories and installed per NFPA standards.
- A one-year limited warranty covers all systems and components. Two-, five-, and ten-year extended warranties are also available.
- Tier 3 EPA-certified for Stationary Emergency Applications
- Alternator Protection
- Battery Rack and Cables
- Customer Connection (standard with Decision-Maker 6000 controller only)
- Local Emergency Stop Switch
- Oil Drain Extension
- Operation and Installation Literature

Alternator Features

- The unique Fast-Response X excitation system delivers excellent voltage response and short circuit capability using a rare-earth, permanent magnet (PM)-excited alternator.
- The brushless, rotating-field alternator has broad range reconnectability.

Other Features

- Kohler designed controller for guaranteed system integration and remote communication.
- The low coolant level shutdown prevents overheating (standard on radiator models only). Integral vibration isolation eliminates the need for under-unit vibration spring isolators.
- Mount up to three circuit breakers to allow circuit protection of selected priority loads.

Generator Set Rating

Standby 130C Rise Ratings

Alternator	Voltage	Ph	Hz	Peak kVA	kW/kVA	Amps
4R9X	120/208	3	60	290	100/125	347

RATINGS: All three-phase units are rated at 0.8 power factor. All single-phase units are rated at 1.0 power factor.
 Standby Ratings: The standby rating is applicable to varying loads for the duration of a power outage. There is no overload capability for this rating.
 Prime Power Ratings: At varying load, the number of generator set operating hours is unlimited. A 10% overload capacity is available for one hour in twelve.
 Ratings are in accordance with ISO-8528-1 and ISO-3046-1. For limited running time and continuous ratings, consult the factory.
 Obtain technical information bulletin (TIB-101) for ratings guidelines, complete ratings definitions, and site condition derates.
 The generator set manufacturer reserves the right to change the design or specifications without notice and without any obligation or liability whatsoever.

Model: 100REOZJF, continued

Alternator Specifications

Specifications	Alternator
Alternator manufacturer	Kohler
Type	4-Pole, Rotating-Field
Exciter type	Brushless, Rare-Earth Permanent-Magnet
Leads, quantity	12, Reconnectable
Voltage regulator	Solid State, Volts/Hz
Insulation	NEMA MG1
Insulation: Material	Class H
Insulation: Temperature Rise	130 ° C, Standby
Bearing: quantity, type	1, Sealed
Coupling	Flexible disc
Amortisseur windings	Full
Voltage regulation, no-load to full-load RMS	Controller Dependent
One-Step Load Acceptance	100% of rating
Unbalanced load capability	100% of Rated Standby Current
<ul style="list-style-type: none"> • NEMA MG1, IEEE, and ANSI standards compliance for temperature rise and motor starting. • Sustained short-circuit current of up to 300% of the rated current for up to 10 seconds. • Sustained short-circuit current enabling down stream circuit breakers to trip without collapsing the alternator field. <ul style="list-style-type: none"> • Self-ventilated and dripproof construction. • Vacuum-impregnated windings with fungus-resistant epoxy varnish for dependability and long life. <ul style="list-style-type: none"> • Superior voltage waveform from a two-thirds pitch stator and skewed rotor. 	

Engine

Engine Specification

Engine Manufacturer	John Deere
Engine Model	4045HF285I
Engine: type	4-Cycle, Turbocharged, Charge Air-Cooled
Cylinder arrangement	4 Inline
Displacement, L (cu. in.)	4.5 (276)
Bore and stroke, mm (in.)	106 x 127 (4.19 x 5.00)
Compression ratio	19:01
Piston speed, m/min. (ft./min.)	457 (1500)
Main bearings: quantity, type	5, Replaceable Insert
Rated rpm	1800
Max. power at rated rpm, kWm (BHP)	118 (158)
Cylinder head material	Cast Iron
Crankshaft material	Forged Steel
Valve (exhaust) material Intake	Chromium-Silicon Steel
Valve (exhaust) material	Stainless Steel
Governor: type, make/model	JDEC Electronic L16 Denso HP3
Frequency regulation, no-load to-full load	Isochronous
Frequency regulation, steady state	± 0.25%
Frequency	Fixed
Air cleaner type, all models	Dry

Model: 100REOZJF, continued

Exhaust

Exhaust System

Exhaust Manifold Type	Dry
Exhaust flow at rated kW, m ³ /min. (cfm)	22.8 (805)
Exhaust temperature at rated kW, dry exhaust, °C (°F)	580 (1076)
Maximum allowable back pressure, kPa (in. Hg)	7.5 (2.2)
Exh. outlet size at eng. hookup, mm (in.)	98 (3.86)

Engine Electrical

Engine Electrical System

Battery charging alternator	12 Volt
Battery charging alternator: Ground (negative/positive)	Negative
Battery charging alternator: Volts (DC)	12
Battery charging alternator: Ampere rating	65
Starter motor rated voltage (DC)	12
Battery, recommended cold cranking amps (CCA): Qty., CCA rating each	One, 640
Battery voltage (DC)	12

Fuel

Fuel System

Fuel type	Diesel
Fuel supply line, min. ID, mm (in.)	11.0 (0.44)
Fuel return line, min. ID, mm (in.)	6.0 (0.25)
Max. lift, fuel pump: type, m (ft.)	Engine-Driven, 1.8 (6.0)
Max. fuel flow, Lph (gph)	74.6 (19.7)
Max. return line restriction, kPa (in. Hg)	20 (5.9)
Fuel prime pump	Manual
Fuel Filter Secondary	2 Microns@ 98% Efficiency
Fuel Filter Primary	30 Microns
Fuel Filter Water Separator	Yes
Recommended fuel	#2 Diesel/HVO/RD

Lubrication

Lubrication System

Type	Full Pressure
Oil pan capacity, L (qt.)	14.7 (15.5)
Oil pan capacity with filter, L (qt.)	15.6 (16.5)
Oil filter: quantity, type	1, Cartridge
Oil cooler	Water-Cooled

Model: 100REOZJF, continued

Cooling

Radiator System

Ambient temperature, ° C (° F)	50 (122)
Engine jacket water capacity, L (gal.)	8.5 (2.25)
Radiator system capacity, including engine, L (gal.)	20.1 (5.3)
Engine jacket water flow, Lpm (gpm)	182 (48)
Heat rejected to cooling water at rated kW, dry exhaust, kW (Btu/min.)	62 (3544)
Heat rejected to air charge cooler at rated kW, dry exhaust, kW (Btu/min.)	20 (1127)
Water pump type	Centrifugal
Fan diameter, including blades, mm (in.)	600 (23.6)
Fan, kWm (HP)	6.6 (8.8)
Max. restriction of cooling air, intake and discharge side of radiator, kPA (in. H ₂ O)	0.125 (0.5)

* Enclosure with internal silencer reduces ambient temperature capability by 5 ° C (9 ° F).

Operation Requirements

Air Requirements

Radiator-cooled cooling air, m ³ /min. (scfm) *	142 (5000)
Combustion air, m ³ /min. (cfm)	8.2 (288)
Heat rejected to ambient air: Engine, kW (Btu/min.)	25.0 (1420)
Heat rejected to ambient air: Alternator, kW (Btu/min.)	11.6 (660)

*Air density = 1.20 kg/m³ (0.075 lbm/ft³)

Fuel Consumption

Diesel, Lph (gph), at % load

Rating

Standby Fuel Consumption at 100% load	31.0 Lph (8.2 gph)
Standby Fuel Consumption at 75% load	25.0 Lph (6.6 gph)
Standby Fuel Consumption at 50% load	17.8 Lph (4.7 gph)
Standby Fuel Consumption at 25% load	9.5 Lph (2.5 gph)



The APM603 generator set controller provides advanced control, system monitoring, and system diagnostics for a single generator set or paralleling multiple generator sets. The APM603 interfaces the generator set to other power system equipment and network management systems using standard industry network communications. It uses a patented digital voltage regulator and unique software logic to manage alternator thermal overload protection as well as serves as an overcurrent protective relay, features normally requiring additional hardware. The APM603 controller meets NFPA 110, Level 1.

Display, Interface, and Accessibility

- A 7-inch color TFT touchscreen for easy local access to data.
 - Home screen can be customized to show critical data at a glance.
 - Create a custom favorites list for quick access to important data
- Measurements are selectable in metric or English units.
- Supports Modbus® protocol through serial bus and Ethernet networks, and supports SNMP and BACnet® through Ethernet networks.

Global Support

- Sales, installation, and service support from more than 800 Kohler and SDMO service providers around the world.

On-board Diagnostics

- Immediate visibility of warnings and faults with text description and code display.
 - 15 seconds of critical data are captured around each warning and fault
 - Critical data can be viewed on the display and downloaded
- Store up to 10,000 events locally along with historical data logging of successful starts.
 - Accurate time stamp from real-time clock
 - Event log can be downloaded
- Data logging of customized parameter list for report generation and advanced troubleshooting.
 - Store to external USB drive for easy transfer to another device

Modbus® is a registered trademark of Schneider Electric.
BACnet® is a registered trademark of ASHRAE.

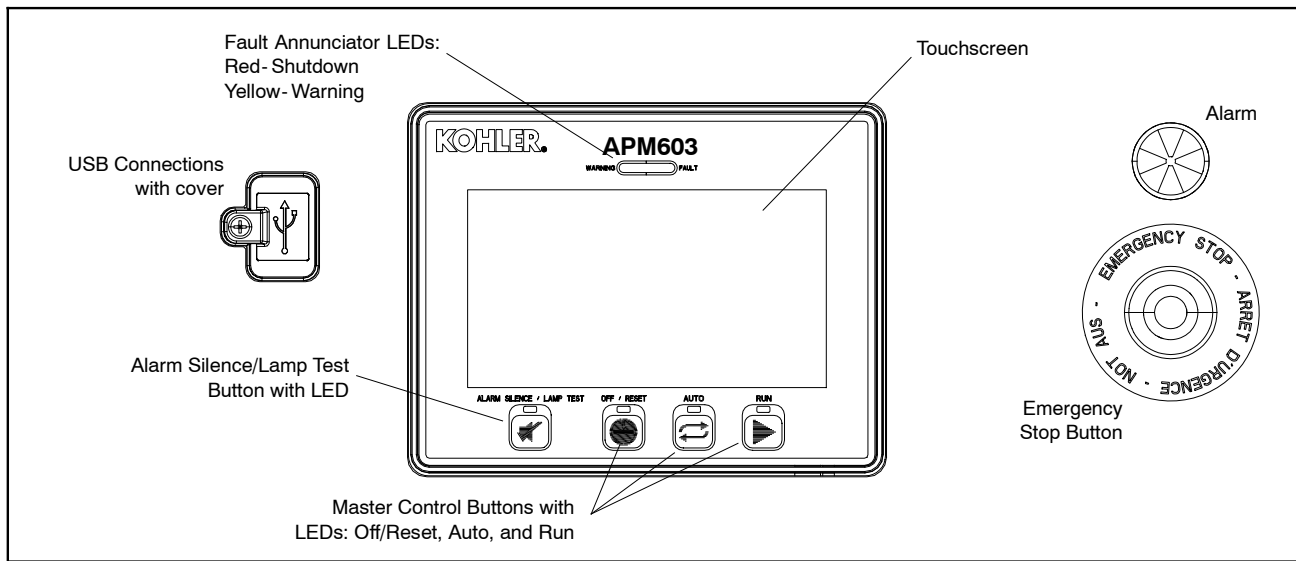

Controller Features

AC Output Voltage Regulator Adjustment	Maximum of $\pm 10\%$ of the system voltage
Alarm Horn	Indicates a generator set warning or shutdown condition
Alarm Silence	For NFPA-110 application or user convenience
Alternator Protection	Generator set overload and short circuit protection
Cyclic Cranking	Provides automatic restart after a failed start attempt with programmable on/off time and number of attempts
ECU Diagnostics	Displays engine ECU fault codes and descriptions for engine troubleshooting
Emergency Stop Button	Shuts down the generator set immediately, for emergency situations
Engine Start Aid	Control for an optional engine starting aid
Environmentally Sealed Membrane Keypad	Three master control buttons with LEDs: Off/Reset, Auto, and Run
Patented High-Speed RMS Digital Voltage Regulator	$\pm 0.25\%$ no-load to full-load regulation with three-phase true RMS sensing
Lamp Test	Verifies functionality of the indicator LEDs
Real-time Clock	Includes battery back-up to retain date and time through controller power cycle
Remote Reset	Allows remote fault resets and restarting of the generator set
Remote Monitoring Panel	Compatible with the Kohler® Remote Serial Annunciator
Run Time Hourmeter	Displays generator set run time
Run Relay	Indicates that the generator set is running
Time Delay Engine Cooldown (TDEC)	Time delay before the generator set shuts down
Time Delay Engine Start (TDES)	Time delay before the generator set starts

Communication

USB Port	(1) Mini-USB port for PC connection (1) USB port for storage device
Serial (RS-485) Port	(1) Non-isolated for RSA III (1) Isolated for Modbus devices (1) Isolated for paralleling communication
Ethernet Port	(1) RJ45 for Modbus TCP, SNMP, and BACnet

Controller Specifications

Nominal voltage	12 or 24 VDC protected against reverse battery connection
Power	800 mAmps at 12 VDC 400 mAmps at 24 VDC
Operating Temperature	-40°C to 70°C (-40°F to 158°F)
Storage Temperature	-40°C to 85°C (-40°F to 185°F)
Humidity	5% to 95% non-condensing
Display Size, W x H	154 x 86 mm (6.0 x 3.4 inches)
Protection Index	IP65 Front

Paralleling Features

- Isochronous control with real and reactive load sharing with other APM603 controller equipped generator sets
 - Supports paralleling up to 8 generators
- Random first-on logic to prevent two or more generator sets from closing to a dead bus and provides the fastest response for a single generator online
- Automatic synchronizer with dead bus closing
- Soft loading and unloading for generator management
- Protective relay functions:
 - Synch check (25C)
 - Over current (51)
 - Over frequency (81O)
 - Over power (32O)
 - Over voltage (59)
 - Reverse power (32R)
 - Reverse reactive power (32RQ)
 - Under frequency (81U)
 - Under voltage (27)
- Generator management to allow the start and stop of generators based on load demand or state of other generators
 - Fuel level
 - Run time
 - Manual order
 - Time of day
 - Efficiency
- Simplified paralleling system view from any generator controller in the system

Overcurrent Protective Device

- Provides protection against line-to-line and line-to-neutral faults
- Uses thermal and instantaneous current limit settings for alternator protection
- Includes a maintenance mode for arc flash reduction per NEC 240.87

Load Management Features

- Programmable outputs included to command the connect and disconnect of loads based on generator or paralleling system state
 - Loads connected based on available capacity
 - Loads disconnected at system startup
 - Loads disconnected based on a maximum kW setting or underfrequency setting
- Supports up to 16 prioritized load steps per system
 - Can be used on a single generator system
 - Can be combined in a paralleling system for a total system load control capability
- Simplified load management system view from any generator controller in the system
- Requires input/output module option

Advanced Programmable I/O

- Configurable inputs and outputs can be programmed for customer specific use
- PLC-like capability for applying logic to customize generator system behavior

Troubleshooting Features

- 15 seconds of key data automatically captured around each warning and shutdown
 - Data can be exported for detailed analysis
 - Data can be viewed on controller for convenient on-site troubleshooting support
- Configurable data logger will allow you to select parameters to monitor
 - Data stored to USB device for flexibility on amount of data stored and ability to export for detailed analysis
 - Data capture controlled by user to allow capturing specific data required

NFPA 110 Requirements

In order to meet NFPA 110, Level 1 requirements, the generator set controller monitors the engine/generator functions/faults shown below.

- Engine functions:
 - Overcrank
 - Low coolant temperature warning
 - High coolant temperature warning
 - High coolant temperature shutdown
 - Low oil pressure shutdown
 - Low oil pressure warning
 - High engine speed
 - Low fuel (level or pressure) *
 - Low coolant level
 - EPS supplying load
 - High battery voltage
 - Low battery voltage
- General functions:
 - Master switch not in auto
 - Battery charger fault *
 - Lamp test
 - Contacts for local and remote common alarm
 - Audible alarm silence button
 - Remote emergency stop *

* Function requires optional input sensors or kits and is engine dependent, see Engine Data.

Standards

The generator set controller has been tested and verified for compliance with the following standards.

- NFPA 99
- NFPA 110, Level 1
- CSA 282-09
- UL 6200
- ASTM B117 (salt spray test)

Controller Functions

The controller displays warning, shutdown, and status messages. **All functions are available as relay outputs.**

Warning causes the yellow fault LED to show and sounds the alarm horn, signaling an impending problem.

Shutdown causes the red fault LED to show, sounds the alarm horn, and stops the generator set.

The controller communicates with the engine ECU and supports a large number of warning and shutdown events that are not listed here. This table highlights the items required for NFPA 110.

Event	Warning	Shutdown
Alternator Thermal Protection †		●
Battery Charger Fault *	▲	
CAN Option Board1 Comm Loss	▲	
Critically Low Fuel Level (diesel) *	▲	
ECU Diagnostic Event	▲	
ECU Mismatch Shutdown †		●
Fuel Leak Alarm (diesel) *	▲	
High Battery Voltage Warning	▲	
High Coolant Temperature Shutdown †		●
High Coolant Temperature Warning	▲	
High Fuel Level Warning (diesel) *	▲	
High Oil Temperature Shutdown †		●
High Oil Temperature Warning	▲	
Local Emergency Stop Shutdown †		●
Loss ECU Comms Shutdown †		●
Loss of Signal Low Coolant Level Voltage	▲	
Low Battery Voltage Warning	▲	
Low Coolant Level Shutdown †		●
Low Coolant Temperature Warning	▲	
Low Fuel Level Shutdown (diesel) * †		●
Low Fuel Level Warning (diesel) *	▲	
Low Fuel Pressure Warning (gas) *	▲	
Low Oil Pressure Shutdown †		●
Low Oil Pressure Warning	▲	
Low RTC (clock) Battery Voltage	▲	
Maintenance Reminder1	▲	
Maintenance Reminder2	▲	
Maintenance Reminder3	▲	
Maximum Power Shutdown †		●
Maximum Power Warning	▲	
Not In Auto Alarm	▲	
Over Crank Shutdown †		●
Over Current Shutdown (L1, L2, L3) †		●
Over Current Warning (L1, L2, L3)	▲	
Over Frequency Shutdown †		●
Over Frequency Warning	▲	
Over Power Shutdown †		●
Over Power Warning	▲	
Over Speed Shutdown †		●
Over Voltage Shutdown (L-L, L-N, each phase) †		●
Over Voltage Warning (L-L, L-N, each phase)	▲	

Event	Warning	Shutdown
Remote Emergency Stop Shutdown †		●
Reverse Power Shutdown †		●
Reverse VAR Shutdown †		●
Under Frequency Shutdown †		●
Under Frequency Warning	▲	
Under Voltage Shutdown (L-L, L-N, each phase) †		●
Under Voltage Warning (L-L, L-N, each phase)	▲	
Weak Cranking Battery	▲	
Status Messages		
Auto Button Pressed		
EPS Supplying Load		
Generator Running		
Generator Started		
Generator Stopped		
GFCI Warning *		
Load Shed Overload		
Load Shed Under Frequency		
Off Button Pressed		
RSA Event Programmable Digital Inputs, 1-8		
Run Button Pressed		
* Function requires optional input sensors or kits		
† Items included with common fault shutdown 10		

John Deere Engine-Powered Models

Inputs and Outputs

Standard Dedicated User Inputs	Input Type
Auxiliary Fault (Shutdown)	Digital Input
Auxiliary Warning	
Battery Charger Fault	
Breaker Closed *	
Breaker Open *	
Excitation Over Voltage (350 kW and up)	
Fuel Leak Alarm	
Low Fuel Level Switch	
Remote Emergency Stop	
Remote Engine Start	Two-wire input
Speed Bias	Analog Voltage Input, Scalable up to +/- 10 VDC
Voltage Bias	

Standard Dedicated User Outputs	Output Type
Close Breaker *	Relay Driver Output
Common Failure	
Run	
Trip Breaker / Shunt Trip *	

* Only with remote-mounted electrically operated circuit breakers.

Optional Configurable User Inputs and Outputs	
User Configurable Inputs	2 Analog, 0-5 VDC 4 Dry Contact Digital
User Configurable Relay Outputs	14 NO/NC Relays 1 Common Fault Relay

Note: Programmable I/O is configurable by a Kohler-authorized technician

JD Engine Data

The following John Deere engine data is displayed on the APM603 controller.

Parameter
Engine Model Number
Engine Serial Number
ECU Serial Number
Coolant Temperature
Engine Speed
Fuel Pressure
Fuel Consumption Rate
Oil Pressure
Run Time Hours

APM603 Available Options

- Common Failure Relay** provides a relay output to signal a generator set fault.
- Battery Charger** available with 6 amp, 10 amp, and 20 amp output for 12 and 24V DC voltage output. (Availability is generator model dependent.) The 10 amp and 20 amp models provide NFPA 110 charging and alarming capability.
- Electrically Operated Circuit Breakers**
 - For paralleling systems
 - Available generator-mounted or remote-mounted
 - 24VDC
- Ground Fault Relay** provides a relay output to signal a ground fault is detected.
- Input/Output Module** for Kohler Diesel (KD) and Mitsubishi models provides:
 - 16 digital input connections with connection to ground
 - 8 relay output connections (Form C, rated 8A, 240 VAC or rated 0.5 A, 48 VDC)
- Input/Output Module** for models other than KD or Mitsubishi provides:
 - 2 analog inputs (0-5 VDC)
 - 4 digital input connections with connection to ground
 - 14 relay output connections (Form C, rated 10A, 120V)
 - 1 common fault relay output (NO, rated 2A, 24VDC)
- Key Switch** to allow selection of RUN, OFF and AUTO modes. Lockable in the AUTO position by removing the key.
- Remote Emergency Stop Switch** available as a wall mounted panel to remotely shut down the generator set.
- Remote Monitoring Panel.** The Kohler® Remote Serial Annunciator (RSA) enables the operator to monitor the status of the generator set from a remote location, which may be required for NFPA 99 and NFPA 110 installations, and up to four Automatic transfer switches.
- Shunt Trip Wiring** provides relay outputs to trip a shunt trip circuit breaker and to signal the common fault shutdowns. Contacts rated at 10 amps at 28 VDC or 120 VAC.

DISTRIBUTED BY:

Availability is subject to change without notice. Kohler Co. reserves the right to change the design or specifications without notice and without any obligation or liability whatsoever. Contact your local Kohler® generator set distributor for availability.

© 2019 Kohler Co., All rights reserved.

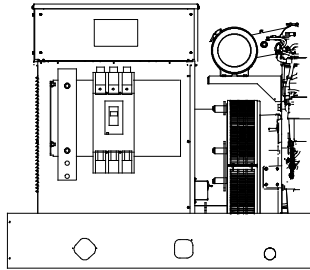

**Single Circuit Breaker Kit with Neutral Bus Bar
15-300 kW Model Shown**

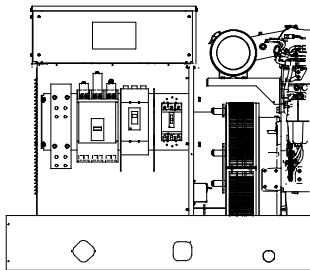

**Multiple Circuit Breaker Kit with Neutral Bus Bar
180-300 kW Model Shown**

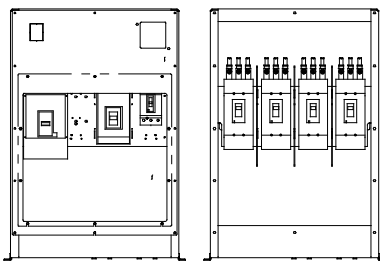

**Multiple Circuit Breaker Kits with Neutral Bus Bar
350-2250 kW Model Shown
(also applies to some 300 kW models)**

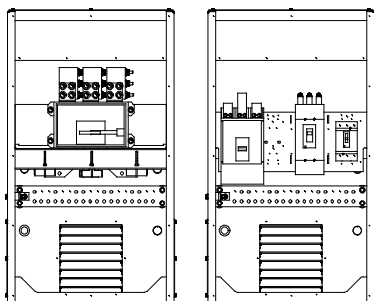

**Circuit Breaker Kits with Neutral Bus Bar
700-2500 kW KD Model Shown**

Standard Features

- The line circuit breaker interrupts the generator set output during a short circuit and protects the wiring when an overload occurs. Use the circuit breaker to manually disconnect the generator set from the load during generator set service.
- Circuit breaker kits are mounted to the generator set and are provided with load-side lugs and neutral bus bar.
- Kohler Co. offers a wide selection of molded-case line circuit breaker kits including single, dual, and multiple configurations for each generator set.
- Four types of line circuit breakers are available: (see page 2 for definitions and pages 3 and 4 for application details)
 - Magnetic trip
 - Thermal magnetic trip
 - Electronic trip
 - Electronic with ground fault (LSIG) trip
- In addition, line circuit breakers are offered with 80% and 100% ratings.
- Single line circuit breaker kits allow circuit protection of the entire electrical system load.
- Dual line circuit breaker kits allow circuit protection of selected priority loads from the remaining electrical system load.
- Multiple line circuit breaker kits with field connection barrier allow circuit protection for special applications (350-2500 kW models and selected 80-300 kW models).
- Up to four line circuit breakers can be used on 350-2500 kW models.
- Line circuit breakers comply with the following codes and standards unless otherwise stated.
 - UL 489 Molded Case Circuit Breakers
 - UL 1077 Supplementary Protectors
 - UL 2200 Stationary Engine Generator Assemblies

Line Circuit Breaker Types

Magnetic Trip

The magnetic trip features an electromagnet in series with the load contacts and a moveable armature to activate the trip mechanism. When a sudden and excessive current such as a short circuit occurs, the electromagnet attracts the armature resulting in an instantaneous trip.

Thermal Magnetic Trip

Thermal magnetic trip contains a thermal portion with a bimetallic strip that reacts to the heat produced from the load current. Excessive current causes it to bend sufficiently to trip the mechanism. The trip delay is dependent on the duration and excess of the overload current. Elements are factory-calibrated. A combination of both thermal and magnetic features allows a delayed trip on an overload and an instantaneous trip on a short circuit condition.

Electronic Trip

These line circuit breakers use electronic controls and miniature current transformers to monitor electrical currents and trip when preset limits are exceeded.

LI breakers are a combination of adjustable trip functions including long-time ampere rating, long-time delay, and instantaneous pickup. LSI breakers have all of the LI breaker features plus short-time pickup, short-time delay, and defeatable instantaneous pickup. LSIG breakers have all of the LSI breaker features plus ground-fault pickup and delay.

NOTE: MG-frame does not have a long-time delay when selected with LI breakers.

Electronic with Ground Fault Trip

The ground fault trip feature is referred to as LSIG in this document. Models with LSIG compare current flow in phase and neutral lines, and trip when current unbalance exists.

Ground fault trip units are an integral part of the circuit breaker and are not available as field-installable kits. The ground fault pickup switch sets the current level at which the circuit breaker will trip after the ground fault delay. Ground fault pickup values are based on circuit breaker sensor plug only and not on the rating plug multiplier. Changing the rating plug multiplier has no effect on the ground fault pickup values.

80% Rated Circuit Breaker

Most molded-case circuit breakers are 80% rated devices. An 80% rated circuit breaker can only be applied at 80% of its rating for continuous loads as defined by NFPA 70. Circuit conductors used with 80% rated circuit breakers are required to be rated for 100% of the circuit breaker's rating.

The 80% rated circuit breakers are typically at a lower cost than the 100% rated circuit breaker but load growth is limited.

100% Rated Circuit Breaker

Applications where all UL and NEC restrictions are met can use 100% rated circuit breakers where 100% rated circuits can carry 100% of the circuit breaker and conductor current rating.

The 100% rated circuit breakers are typically at a higher cost than the 80% rated circuit breaker but have load growth possibilities.

When applying 100% rated circuit breakers, comply with the various restrictions including UL Standard 489 and NEC Section 210. If any of the 100% rated circuit breaker restrictions are not met, the circuit breaker becomes an 80% rated circuit breaker.

Line Circuit Breaker Options

Alarm Switch

The alarm switch indicates that the circuit breaker is in a tripped position caused by an overload, short circuit, ground fault, the operation of the shunt trip, an undervoltage trip, or the push-to-trip pushbutton. The alarm resets when the circuit breaker is reset.

Auxiliary Contacts

These switches send a signal indicating whether the main circuit breaker contacts are in the open or closed position.

Breaker Separators (350- 2500 kW)

Provides adequate clearance between breaker circuits.

Bus Bars

Bus bar kits offer a convenient way to connect load leads to the generator set when a circuit breaker is not present. **15- 300 kW.** Bus bar kits are available on alternators with leads for connection to the generator set when circuit breakers are not ordered.

350- 2500 kW. A bus bar kit is provided when no circuit breaker is ordered. Bus bars are also available in combination with circuit breakers or other bus bars on the opposite side of the junction box. On medium voltage (3.3 kV and above) units, a bus bar kit is standard (not applicable to KD models).

Field Connection Barrier

Provides installer wiring isolation from factory connections.

Ground Fault Annunciation

A relay contact for customer connection indicates a ground fault condition and is part of a ground fault alarm.

Lockout Device (padlock attachment)

This field-installable handle padlock attachment is available for manually operated circuit breakers. The attachment can accommodate three padlocks and will lock the circuit breaker in the OFF position only.

Lugs

Various lug sizes are available to accommodate multiple cable sizes for connection to the neutral or bus bar.

Overcurrent Trip Switch

The overcurrent trip switch indicates that the circuit breaker has tripped due to overload, ground fault, or short circuit and returns to the deenergized state when the circuit breaker is reset.

Shunt Trip, 12 VDC or 24 VDC

A shunt trip option provides a solenoid within the circuit breaker case that, when momentarily energized from a remote source, activates the trip mechanism. This feature allows the circuit breaker to be tripped by customer-selected faults such as alternator overload or overspeed. The circuit breaker must be reset locally after being tripped. Tripping has priority over manual or motor operator closing.

Shunt Trip Wiring

Connects the shunt trip to the generator set controller. (standard on KD models with the APM802 controller)

Undervoltage Trip, 12 VDC or 24 VDC

The undervoltage trips the circuit breaker when the control voltage drops below the preset threshold of 35%- 70% of the rated voltage.

15- 300* kW Line Circuit Breaker Specifications

* Includes models 300REOZJ and 300REZXC. For other 300 kW models, see the 300- 2250 kW section.

100% Rating Circuit Breaker

Alt. Model	Ampere Range	Trip Type	C. B. Frame Size	
4D/4E	15- 150	Thermal magnetic	HD	
		Electronic LI		
		Electronic LSI		
	60- 150	Electronic LSI		
		Electronic LSI		HG
		Electronic LSI		
Electronic LSI				
4P/4PX 4Q/4QX	15- 150	Thermal magnetic	HD	
		Electronic LI		
		Electronic LSI		
	60- 150	Electronic LSI		
		Electronic LSI		HG
		Electronic LSI		
	Electronic LSI			
	175- 250	Thermal magnetic	JD	
	250	Electronic LI	JD	
		Electronic LSI		
		Electronic LSI		
		250	Electronic LI	JG
			Electronic LSI	
			Electronic LSI	
	400	Electronic LI	LG	
		Electronic LSI		
		Electronic LSI		
	4RX 4S/4SX 4TX 4V 4UA 4M6226	15- 150	Thermal magnetic	HD
Electronic LI				
Electronic LSI				
60- 150		Electronic LSI		
		Electronic LSI	HG	
		Electronic LSI		
Electronic LSI				
175- 250		Thermal magnetic		JD
250		Electronic LI		
		Electronic LSI		
		Electronic LSI		
250		Electronic LI	JG	
		Electronic LSI		
		Electronic LSI		
400		Electronic LI	LG	
		Electronic LSI		
		Electronic LSI		
600- 800		Electronic LSI	PG	
	Electronic LSI			
	Electronic LSI			
4UA 4M6226	1000- 1200	Electronic LSI	PG	
		Electronic LSI		
	1200	Electronic LSI	PJ	
		Electronic LSI		

100% Rating Electrically Operated Breakers

For use as paralleling breakers with the Decision-Maker® 6000 Controller/DPS System or APM603 controller.

Generator-Mounted P-Frame, 24VDC Electrically Operated			
Alt. Model	Amps	Trip Unit	Frame
4RX 4S/4SX 4TX 4V	250	3.0 LI	PJ
	400	5.0 LSI	PJ
	600	3.0 LI	PL
	800	5.0 LSI	PL
4UA 4M6226	250	3.0 LI	PJ
	400	5.0 LSI	PJ
	600	3.0 LI	PL
	800	5.0 LSI	PL
	1200	5.0 LSI	PL

All circuit breakers listed in this table include line side bus and load side lugs, 24VDC motor operators, 2 type C auxiliary contacts, and 1 type C SDE overcurrent switch contact. No second breakers are allowed in combination with these breakers.

Interrupting Ratings

Circuit Breaker Frame Size	240 Volt, kA	480 Volt, kA	600 Volt, kA
HD	25	18	14
HG	65	35	18
HJ	100	65	25
JD	25	18	14
JG	65	35	18
JJ	100	65	25
LA	42	30	22
LG	65	35	18
MG			
PG	65	35	18
PJ	100	65	25
PL	125	100	25

Circuit Breaker Lugs Per Phase (Al/Cu)

Frame Size	Ampere Range	Wire Range
E (480 V max.)	30- 100	Up to two wire terminals fitting 10-32 or 1/4-20 stud
H	15- 150	One #14 to 3/0
J	175	One 1/0 to 4/0
	200- 250	One 3/0 to 350 kcmil
LA	300- 400	One #1 to 600 kcmil or Two #1 to 250 kcmil
LG	400- 600	Two 2/0 to 500 kcmil AL/CU
M	800	Three 3/0 to 500 kcmil
P	600-800	Three 3/0 to 500 kcmil
	1000-1200	Four 3/0 to 500 kcmil

Mechanical Load Lugs Included with H, J, and LG LSI Neutrals		
H	60- 150	One #14 to 3/0 AL/CU
J	250	One 3/0 to 350 kcmil AL/CU
LG	400- 600	Two 4/0 to 500 kcmil AL/CU

15- 300* kW Line Circuit Breaker Applications

* Includes models 300REOZJ and 300REZXC. For other 300 kW models, see the 300- 2250 kW section.

Single Circuit Breaker Installations

A generator set with a single circuit breaker installed typically feeds a single transfer switch and then a distribution panel. This allows protection of the entire system.

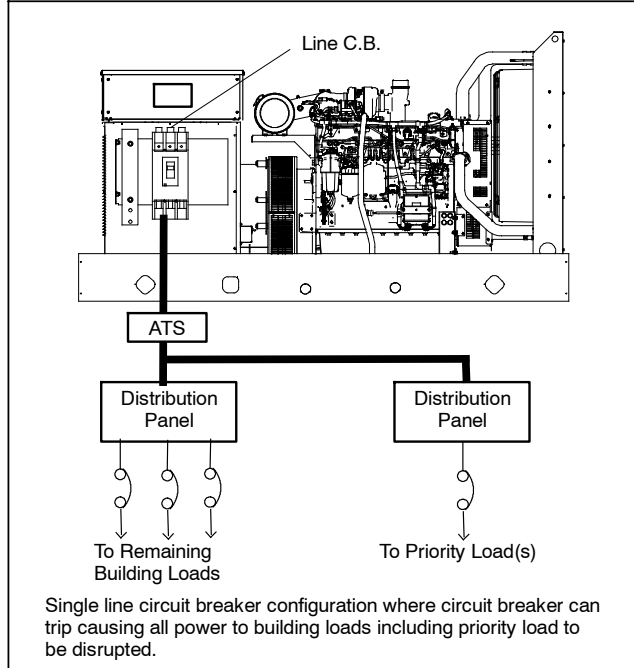

Multiple Circuit Breaker Installations

A generator set with dual circuit breakers installed is used to separate critical loads. Typically, one circuit breaker will feed a main transfer switch with noncritical loads and the other circuit breaker will feed a second transfer switch that feeds critical or priority loads. Multiple circuit breakers allow circuit protection for special applications.

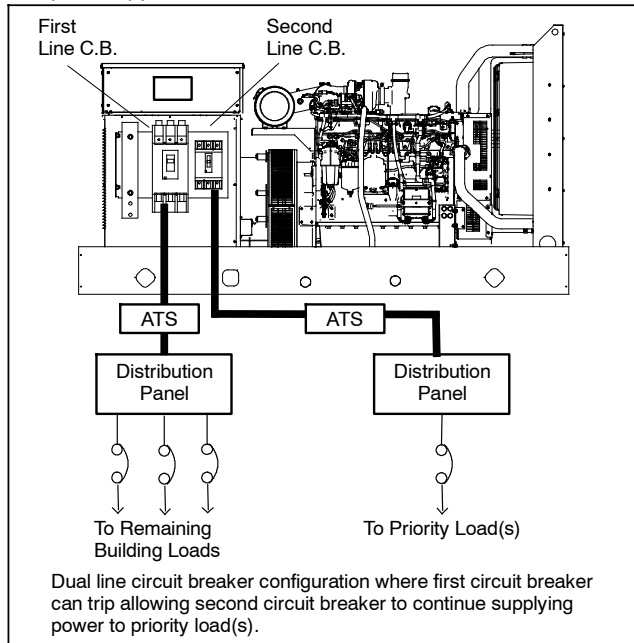

Circuit Breaker Combinations

Alternator Model	First C. B. Frame	Second C. B. Frame	Third C. B. Frame	Trip Type
ALL except 4D/4E	H	—	—	All
	J	—	—	
	LA	—	—	
	LG	—	—	
4D/4E	H	—	—	Standard or LSIG
	H	H	—	No LSIG
4P/4PX 4Q/4QX	H	H or J	—	No LSIG
	J		—	
	LA	—		
	LG	H, J or LG	—	
4RX 4S/4SX 4TX 4V	M	—	—	All
	P	—	—	All
	H or J	H or J	—	No LSIG
	LA	H, J, or LA	—	
	LG	H, J, LA, or LG	—	
	M		—	
	P	—	—	
H or J	H or J	H or J		
4UA 4M6226	M or P	—	—	All
	H or J	H or J	—	All
	LA	H, J, or LA	—	
	LG	H, J, LA, or LG	—	
	M or P	H, J, LA, or LG	—	
	P	P	—	
	H or J	H or J	H or J	
	LA	H or J	H or J	
		LA	H, J, or LA	
	LG	H or J	H or J	
LA		H, J, or LA		
M or P	LA	H, J, or LA		
	LG	H, J, or LG		

PowerPact™ H-, J-, and L-Frame Circuit Breakers Trip Curves

Figure 96: Micrologic 3.3S and 3.3S-W Electronic Trip Unit Long Time/Short Time Trip Curve

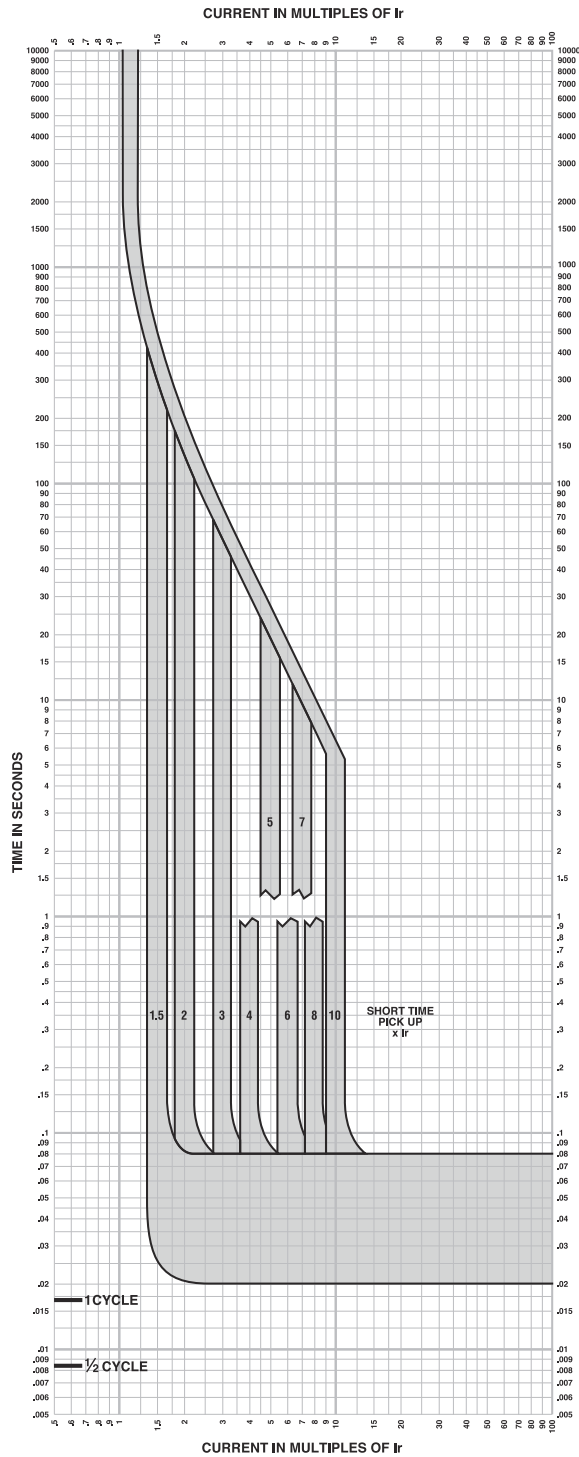

MICROLOGIC™ ELECTRONIC TRIP UNITS Micrologic™ 3.3S and 3.3S-W Long Time/Short Time Trip Curve 250A, 400A L-Frame

The time-current curve information is to be used for application and coordination purposes only.

Notes:

1. There is a thermal-imaging effect that can act to shorten the long-time delay. The thermal imaging effect comes into play if a current above the long-time delay pickup value exists for a time and then is cleared by the tripping of a downstream device or the circuit breaker itself. A subsequent overload will cause the circuit breaker to trip in a shorter time than normal. The amount of time delay reduction is inverse to the amount of time that has elapsed since the previous overload. Approximately 20 minutes is required between overloads to completely reset thermal-imaging.
2. Total clearing times shown include the response times of the trip unit, the circuit breaker opening, and the extinction of the current.

Curves apply from -35°C to +70°C (-31°F to +158°F) ambient temperature.



Typical Overall Dimensions

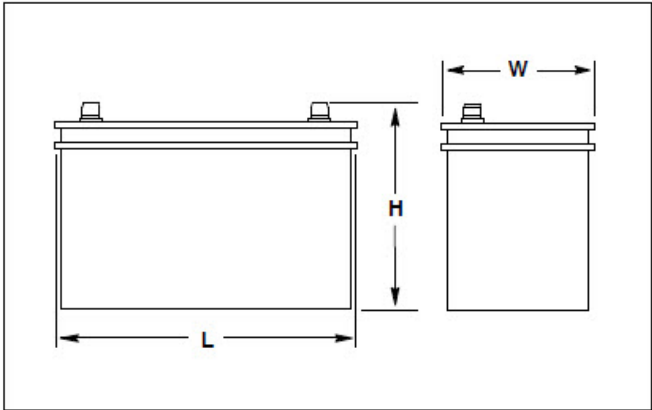

Standard Features

- Kohler Co. selects batteries to meet the engine manufacturer's specifications and to comply with NFPA requirements for engine-cranking cycles.
- Heavy-duty starting batteries are the most cost-effective means of engine cranking and provide excellent reliability in generator set applications.
- Tough polypropylene cases protect against life-shortening vibration and impact damage.
- Batteries are rated according to SAE standard J-537.
- All batteries are 12-volts. Kits that contain two or four batteries are available for 24-volt systems and/or systems with redundant starters.
- Wet- and dry-charged batteries have lead-calcium or lead-antimony plates and use sulfuric acid electrolyte. Removable cell covers allow checking of electrolyte specific gravity.
- Absorbant glass mat (AGM) batteries are sealed and maintenance free.
- Batteries are for applications below and above 0 ° C (32 ° F).

Charge Type*	Battery Part Number	Battery Qty. per Size	BCI Group Size	Battery SAE Dimension, mm (in.)			Cold Cranking Amps at 18°C (0°F) Min.	Reserve Capacity Minutes at 27° (80°F) Min.	Battery Post Layout and Style
				L	W	H			
Wet	256984	1	24	273.0 (10.8)	173.0 (6.8)	228.6 (9.0)	650	130	D/1

Battery Specifications

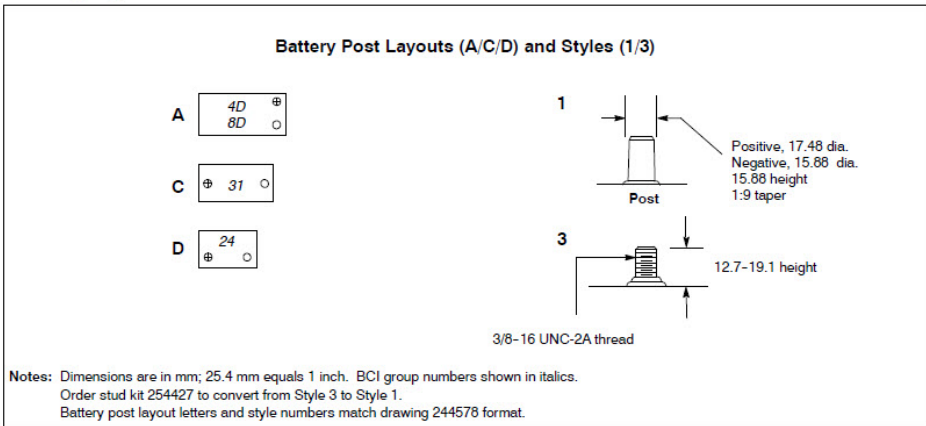

12/24 Volt, 10 Amp

Automatic Multi-Stage Battery Charger

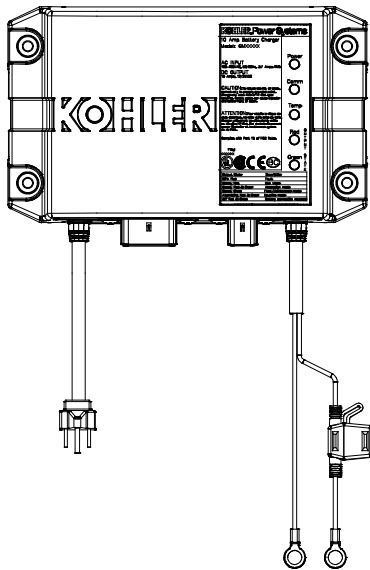

The battery charger is a fully-automatic, high efficiency battery charger that charges batteries rapidly and safely. The battery charger is designed for an industrial environment.

The battery charger is designed for operation with an engine cranking battery.

The battery charger is universal voltage input capable, comes with a standard 120 V/60 Hz AC plug, and charges 12 VDC or 24 VDC battery systems.

Five LED lights indicate power, communication status, temperature compensation status, charge curve, and charger status.

With the optional battery temperature sensor connected, the battery charger can adjust output voltages for optimal charging.

Standard Features

- 12 or 24 VDC output
 - Automatic voltage detection
- Automatic multi-stage charging modes
 - Recovery charge
 - Bulk charge
 - Absorption charge
 - Float charge
 - Equalize charge
- Charges the following type batteries:
 - Flooded lead acid (FLA)
 - AGM
 - Gel cell
 - High performance AGM
 - Nickel-cadmium (NiCad)
- 5 LED status indicators
- Durable potted assembly for waterproofing and vibration resistance
- Reverse-polarity protection
- Short-circuit protection
- Electronically limited output current
- Optional temperature compensation (FLA only)
- User adjustable parameters to support optimal manufacturer recommended charge curve.
- Code compliance:
 - UL 1236 Listed
 - NFPA 110, Level 1 compatible (when used with Kohler controller and connected to engine harness)
 - CSA - C22.2 No. 107.2-01
 - FCC - Title 47, Part 15 Class A
 - CE
 - IBC 2015
 - OSHPD

DC Output		AC Input		Overall Dimensions W x D x H	Shipping Weight	
Volts (Nominal)	Amps	Volts (Nominal)	Amps		kgs	lbs
12/24	10	100-260	3.7	253 mm x 152 mm x 74 mm (10.0 in x 6.0 in x 2.9 in)	3.6	7.9

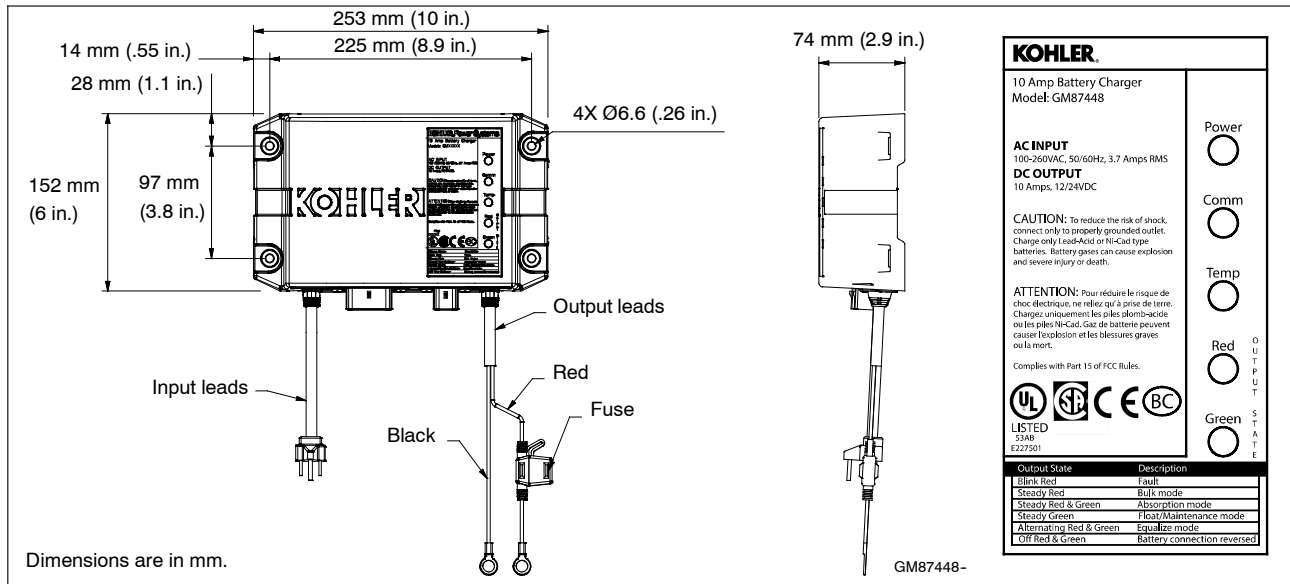

Specifications

AC Input	100-260 VAC
Frequency Input	50/60 Hz
DC Output	10 Amps @ 12 VDC or 10 Amps @ 24 VDC (On battery voltage regulation ±1%; current is electronically limited)
Fuse Protection	15 amps ATC
Battery Types	Flooded Lead Acid (FLA) AGM Gel Cell High Performance AGM Nickel-Cadmium (NiCad)
Monitoring LED Indications	Power Communication Temperature compensation Output charger curve and charger status: <ul style="list-style-type: none"> ○ Red ○ Green
Environmental	
Operating	-20° to 70°C (-4° to 158° F)
Storage	-40° to 85°C (-40° to 185° F)
Relative Humidity	5 to 95% (non-condensing)
Salt Spray Testing	ASTM B117
Corrosion Resistant	From battery gases

Enclosure	
Environmental Resistant	From rain, snow, dust, and dripping water
Battery Connections	
Lead Length	1.8 m (6 ft.) red and black leads
Battery Connections	9.5 mm (3/8 in.) ring terminals
AC Power Connections	
Lead Length	1.8 m (6 ft.)
Storage	Standard US style 3-prong AC plug
Available Options	Temperature compensation

DISTRIBUTED BY:

Availability is subject to change without notice. Kohler Co. reserves the right to change the design or specifications without notice and without any obligation or liability whatsoever. Contact your local Kohler® generator distributor for availability.

© 2017, 2019 by Kohler Co. All rights reserved.

Sound Enclosure Standard Features

- Internal-mounted critical silencer and flexible exhaust connector.
- Lift base-mounted or tank mounted steel construction with hinged doors.
- Fade-, scratch-, and corrosion-resistant Kohler® Power Armor automotive-grade textured finish.
- Power Armor surpasses 3,000-hour salt spray corrosion tests per ASTM B- 1117
- Enclosure has four access doors which allow for easy maintenance.
- Lockable, flush-mounted door latches.
- Vertical air inlet and outlet discharge to redirect air and reduce noise.
- Acoustic insulation that meets UL 94 HF1 flammability classification and repels moisture adsorption.
- Sound-attenuated that uses up to 51 mm (2 in.) of acoustic insulation.
- Steel sound enclosure is designed to 150 mph (241 kph) wind load rating.

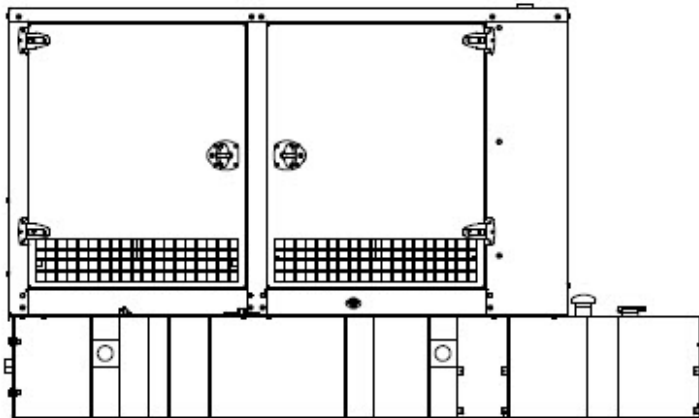

Enclosure with State Code Subbase Fuel Tank

Subbase Fuel Tank Features

- The fuel tank has a Power Armor Plus textured epoxy-based rubberized coating.
- The above-ground rectangular secondary containment tank mounts directly to the generator set, below the generator set skid (subbase).
- Both the inner and outer tanks have emergency relief vents.
- Flexible fuel lines are provided with subbase fuel tank selection.
- The secondary containment generator set base tank meets UL 142 tank requirements. The inner (primary) tank is sealed inside the outer (secondary) tank. The outer tank contains the fuel if the inner tank leaks or ruptures.
- State tanks with varying capacities are an available option. Florida Dept. of Environmental Protection (FDEP) File No. EQ-634 approved.

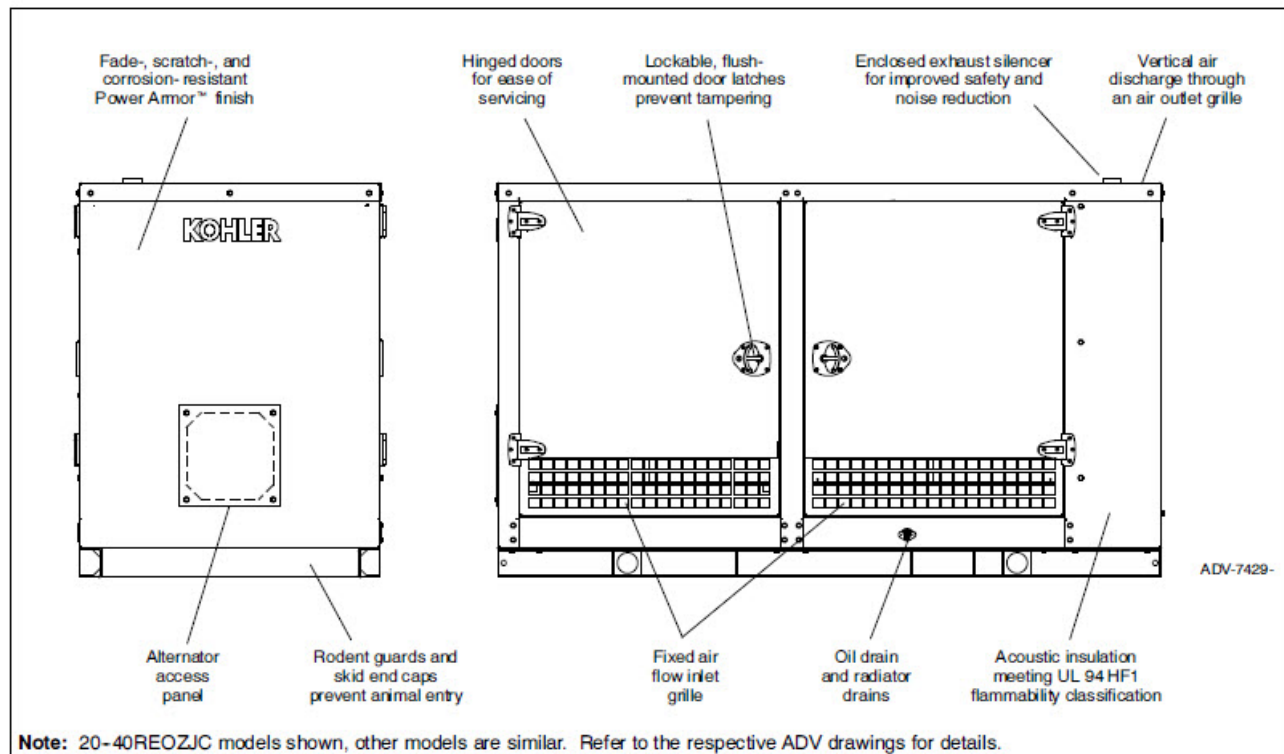

Sound Enclosure Features

- Available in steel (14 gauge) formed panel, solid construction. Preassembled package offering corrosion resistant, dent resilient structure mounting directly to lift base or fuel tank.
- Power Armor automotive-grade finish resulting in advanced corrosion and abrasion protection as well as enhanced edge coverage and color retention.
- Internal exhaust silencer offering maximum component life and operator safety.
- Interchangeable modular panel construction. Allows complete serviceability or replacement without compromising enclosure design.
- Cooling/combustion air intake with a horizontal air inlet. Sized for maximum cooling airflow.
- Service access. Multi-personnel doors for easy access to generator set control and servicing of the fuel fill, fuel gauge, oil fill and battery.
- Cooling air discharge. Weather protective design featuring vertical air discharge. Redirects cooling air up and above the enclosure to reduce ambient noise.
- Attenuated design. Acoustic insulation UL 94 HF1 listed for flame resistance offering up to 51 mm (2 in.) mechanically restrained acoustic insulation.
- Cooling air discharge. The sound enclosures include acoustic insulation with urethane film.
- Note: Installing an additional length of exhaust tail pipe may increase backpressure levels. Please refer to the generator set spec sheet for the maximum backpressure value.

State Code Subbase Fuel Tank

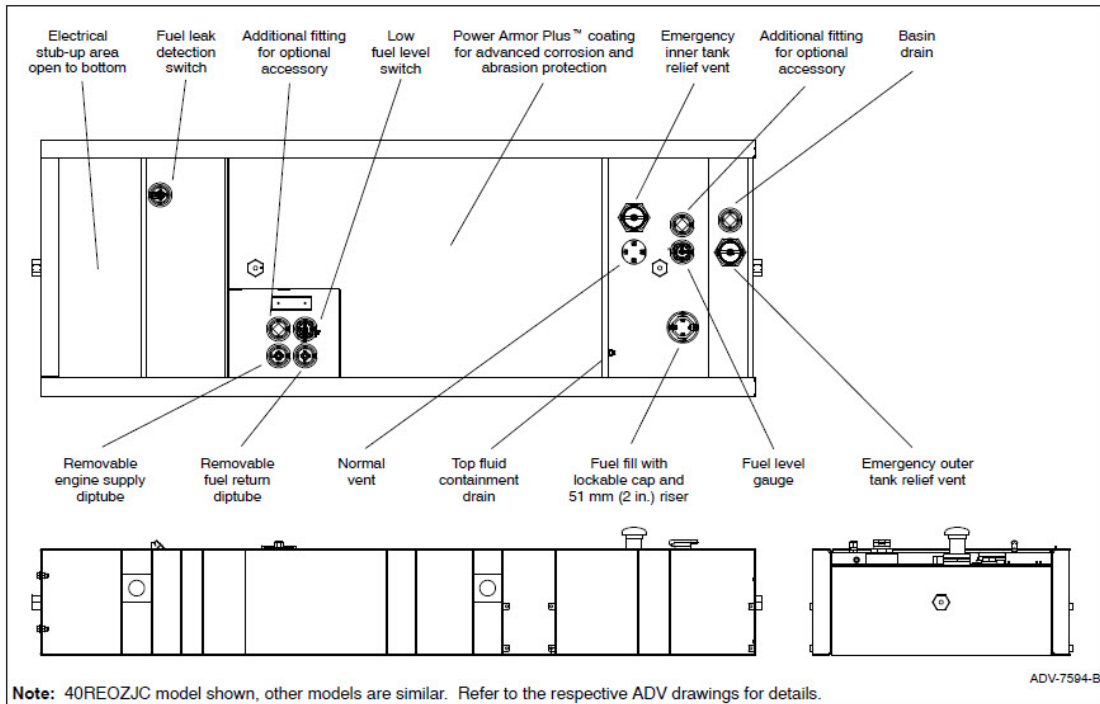

- Extended operation. Usable tank capacities offers full load standby operation of up to 72 hours.
- Power Armor Plus textured epoxy-based rubberized coating that creates an ultra-thick barrier between the tank and harsh environmental conditions like humidity, saltwater, and extreme temperatures, and provides advanced corrosion and abrasion protection.
- UL listed. Secondary containment generator set base tank meeting UL 142 tank requirements.
- NFPA compliant. Designed to comply with the installation standards of NFPA 30 and NFPA 37.
- Integral external lift lugs. Enables crane with spreader-bar lifting of the complete package (empty tank, mounted generator set, and enclosure) to ensure safety.
- Emergency pressure relief vents. Meets UL requirements; ensures adequate venting of inner and outer tank under extreme pressure and/or emergency conditions.
- Normal vent with cap. Vent is raised above lockable fuel fill.
- Low fuel level switch. Annunciates a 50% low fuel level condition at generator set control.
- Leak detection switch. Annunciates a contained primary tank fuel leak condition at generator set control.
- Electrical stub-up.
- State tank designed to comply with the installation standards of the Florida Dept. of Environmental Protection (FDEP) File No. EQ-634.

Fuel Tank Capacity, L (gal.)	Est. Fuel Supply Hours at 60 Hz with Full Load	Enclosure and Fuel Tank Length, mm (in.)	Enclosure and Fuel Tank Width, mm (in.)	Enclosure and Fuel Tank Weight, kg (lb.)	Enclosure and Fuel Tank Height, mm (in.)	Fuel Tank Height (H), mm (in.)	Sound Pressure Level, dB(A)
814 (215)	24/26	3400 (133.9)	1156 (45.5)	2105 (4641)	2111 (83.1)	432 (17)	69

Note: Data in table is for reference only, refer to the respective ADV drawings for details.

Note: Refer to TIB-114 for generator set sound data.

Max. weight includes the generator set (wet), enclosure, silencer, and tank (no fuel). The generator set weight represents using the largest alternator option. The enclosure weight is with acoustic insulation added.

Engine Block Heater Kits

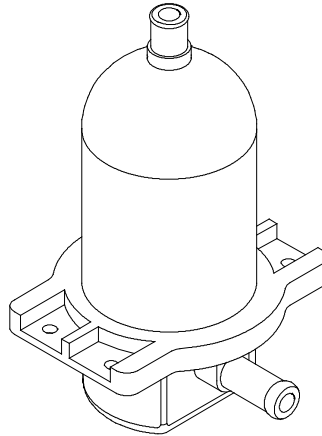

Block Heater Kit, typical

Applicable Models

- KG40- KG125
- KG150- KG200
- KG150R
- 25- 45REZG
- 25- 60REZGB
- 50REZGC/125REZGC/150REZGC
- 50- 60REOZJD
- 50REOZJE
- 80REZGD/100REZGD
- 80RZGD/100RZGD
- 80- 200REOZJF
- 80- 150REOZJG4
- 125RZGC/150RZGC
- 125REOZJG/180REOZJG

Standard Features

- UL- C/US listed
- CE compliant
- Controls for automatic operation
- Compact design
- Easy to install

Description

The engine block heater kit heats the engine coolant in cold ambient, warming the cylinders, oil, and charge air circuit which all help to give a faster starting time. The engine block heater uses thermosiphon action to circulate warm coolant into the engine and supplies constant heating to the engine. The engine block heater kit helps to extend element life and gives a significant reduction in electrical consumption.

The engine block heater kit is recommended for ambient temperatures below 10°C (50°F).

The engine block heater kits are available in 120 V, 240 V, and 277 V versions.

Block Heater Specifications

Heating Fluid	Water, Coolant Mix (50% Glycol/50% Water)
Max. Pressure	90 psi (620 kPa)
Heating Element Material	Incoloy 800
Inlet/Outlet Plumbing	0.625 in. hose barb
System Ingress	IP41
Power Connection	NEMA Plug and EURO Plug
Power Chord Length	48 in. (1219 mm)

Specifications

Block Heater Kit Number	Component	Watts	Voltage	Phase	Thermostat Temperature	
					ON	OFF
GM58098- KA1	358311	1000	120	1	27°C (80°F)	38°C (100°F)
GM75536- KA1	326228	1500	120	1	49°C (120°F)	60°C (140°F)
GM75555- KA5	GM75552	1800	120	1	27°C (80°F)	38°C (100°F)
GM75555- KA6	GM75553	2000	240	1		
GM75556- KA1	352945	1500	120	1		
GM75557- KA1	352945	1500	120	1		
GM75564- KA1	358311	1000	120	1		
GM75565- KA1	352945	1500	120	1		
GM77944- KA1	352945	1500	120	1		
GM77944- KA2	352946	1500	240	1		
GM85060- KA1	GM75552	1800	120	1		
GM85060- KA2	GM75553	2000	240	1		
GM89427- KA2	GM75552	1800	120	1		
GM91708- KA1	352945	1500	120	1		
GM94248- KA1	352945	1500	120	1		
GM104799- KA1	352945	1500	120	1		
GM105165- KA1	352945	1500	120	1		
GM105165- KA2	352946	1500	240	1		
GM105409- KA1	352945	1500	120	1		
GM105409- KA2	352946	1500	240	1		



**Integral Voltage Regulator with Kohler® APM603
Controllers and Menu-Driven Selections (80-4000 kW
Generator Set Models)**

Voltage Regulators

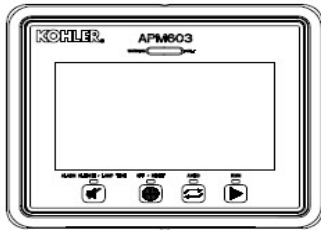

**APM603 Controller
with Integral Voltage Regulator**

The following information provides general features, specifications, and functions of available voltage regulators.

This information generally applies to a single generator set and multiple generator sets with paralleling applications. Refer to the respective generator set specification sheet and see your authorized distributor for information regarding specific voltage regulator applications and availability.

The voltage regulator is integral to the controller and uses patented high speed digital voltage regulator design providing $\pm 0.25\%$ no-load to full-load regulation using root-mean-square (RMS) voltage sensing.

Integral Voltage Regulators with APM603

Calibration	Range Settings	Default Selection
Voltage Adjustment	$\pm 10\%$ of System Voltage	System Voltage
Controller Gain	40 to 70 Hz	P: 1.3 I: 1.0 D: 0.25
Underfrequency Unload or Frequency Setpoint	40 to 70 Hz	0.5 Hz Below System Frequency (ECM)
Underfrequency Unload Scope	0-10% of System Voltage (Volts per Cycle)	15 volts per Cycle at 480 Volts (3.1%)
Reactive Droop	0-10% of System Voltage	4% of System Voltage
VAR Control	-50% to 110%	0 kVAR
PF Adjust Control	-0.50 to 1.0 to 0.50	0.8 Lagging
VAR/PF Gain Adjustment	P: 0.3 to 3.00 I: 0.3 to 3.00 D: 0.3 to 3.00	P: 1.0 I: 1.0 D: 0.25



Specification/Feature	Integral with APM603
Generator Set Availability	80-4000 kW
Type	Patented Hybrid Design
Status and Shutdown Indicators	LEDs and Text LCD Display
Operating Temperature	-40 ° C to 70 ° C (-40 ° F to 158 ° F)
Storage Temperature	-40 ° C to 85 ° C (-40 ° F to 185 ° F)
Humidity	5-95% Non-Condensing
Circuit Protection	Solid-State, Redundant Software and Fuses
Sensing, Nominal	100-600 Volts (L-L), 50-60 Hz
Sensing Mode	RMS, Single- or 3-Phase
Input Requirements	8-36 VDC
Continuous Output	5.0 ADC with GM88453 Activator Board
Maximum Output	7.8 ADC with GM88453 Activator Board
Transition Frequency	50-70 Hz
Exciter Field Resistance	4-30 Ohms with GM88453 Activator Board
No-Load to Full-Load Voltage Regulation	± 0.25%
Thermal Drift	<0.5% (-40 ° C to 70 ° C) [-40 ° F to 158 ° F] Range
Response Time	3-phase: 1 mS 1-phase: 5 mS
System Voltage Adjust.	± 10%
Voltage Adjustment	Controller Display
Remote Voltage Adjustment	Analog 0-5 VDC (± 10%) Input Optional
Paralleling Capability	Full Load Share and Control plus Reactive Droop

Integral Voltage Regulator with APM603 Controller

- A 7.5-inch color TFT touchscreen provides access to data.
- The controller provides an interface between the generator set and switchgear for paralleling applications incorporating multiple generator set and/or utility feeds.
- The controller can control Fast Response™ II, Fast Responset™X, and PMG alternators using the GM88453 activator board.

Voltage Regulator Settings, APM603 Controller

- Voltage Regulator Configuration
 - Under Frequency Unload Settings
 - Single and Three Phase Sensing
 - Voltage Target
 - Voltage Regulator Gains

Paralleling Settings, APM603

- Synchronizing parameters setup
 - Voltage matching
 - Frequency matching
 - Phase matching
 - Time delay
- Load sharing
 - kW sharing
 - kVAR sharing
 - Baseload settings
 - Droop

Paralleling Metering, APM603

- Paralleling State
- Paralleling Mode
- System Voltage
- System Frequency
- Connected Generators
- Sync Status
- Engine Speed

VAR/PF Control Input	VAR Control Mode, PF Control Mode, System VAR Control, System PF Control
----------------------	--

Activator Board GM88453

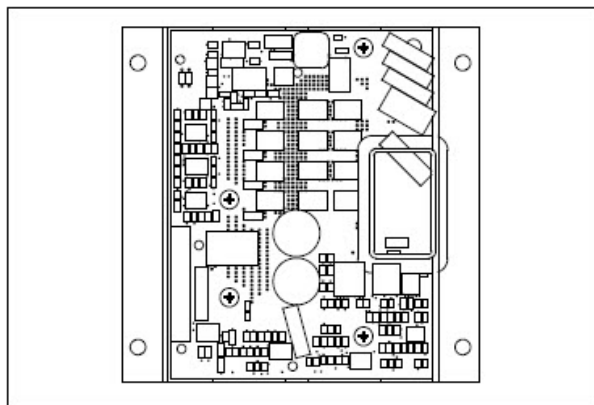

- Interfaces between the controller and alternator assembly using rotor field leads, auxiliary power windings, and optic board leads.
- Allows the Decision-Maker® controllers the ability to control a wound-field alternator using the same control signal as Fast Response
- Permits the generator set controller to control the current to the exciter field of a wound-field excited alternator.
- Contains two isolated relay driver outputs (RDO) rated at 250 mA. Provides RDO outputs indicating a field over-excitation condition and that the alternator is supplying voltage to the activator.

Modbus® is a registered trademark of Schneider Electric.

KOHLER®

Alternator Data

TECHNICAL INFORMATION BULLETIN

Alternator Data Sheet

Alternator Model: 4R9X
Frequency: 60 Hz
Speed: 1800 RPM
Leads: 12 (6 Lead, 600 Volt)

Voltage L-N/L-L	Phase	Power Factor	Connection	kW* (kVA)						
				Class B	Class F				Class H	
				80°C Continuous	90°C Lloyds	95°C ABS	105°C Continuous	130°C Standby	125°C Continuous	150°C Standby
139/240 277/480	3	0.8	Wye	84.0 (105.0)	88.5 (110.5)	90.5 (113.0)	95.0 (118.5)	103.0 (128.5)	101.5 (126.5)	109.5 (136.5)
127/220 254/440	3	0.8	Wye	83.0 (103.5)	87.5 (109.0)	89.5 (111.5)	93.5 (116.5)	101.5 (126.5)	100.0 (125.0)	108.0 (135.0)
120/208 240/416	3	0.8	Wye	82.0 (102.5)	86.0 (107.5)	88.0 (110.0)	92.0 (115.0)	100.5 (125.5)	98.5 (123.0)	106.5 (133.0)
110/190 220/380	3	0.8	Wye	74.5 (93.0)	78.0 (97.5)	80.0 (100.0)	84.5 (105.5)	91.5 (114.0)	89.5 (111.5)	96.5 (120.5)
120/240	3	0.8	Delta	82.0 (102.5)	86.0 (107.5)	88.0 (110.0)	92.0 (115.0)	100.5 (125.5)	98.5 (123.0)	106.5 (133.0)
120/240	1	1.0	Dogleg	64.5 (64.5)	67.5 (67.5)	68.5 (68.5)	71.0 (71.0)	77.5 (77.5)	76.5 (76.5)	82.5 (82.5)
347/600	3	0.8	Wye	83.5 (104.0)	88.0 (110.0)	90.0 (112.5)	94.5 (118.0)	102.5 (128.0)	101.0 (126.0)	109.0 (136.0)

* All data tested in accordance with IEEE Standard 115. Kohler Co. reserves the right to change the design or specifications without notice and without any obligation or liability whatsoever.

Submittal Data: 139/240 Volts, 0.8 PF, 1800 RPM, 60 Hz, 3 Phase, 130°C Rise

	Symbol	PerUnit	Ohms		Symbol	Value
Typical Cold Resistances				Typical Time Constants		
Phase Resistance		0.036	0.016	Armature Short Circuit	T _a	0.007 sec.
Rotor Resistance		16.96	7.585	Transient Short Circuit	T' _d	0.065 sec.
Typical Reactances				Transient Open Circuit	T' _{do}	0.748 sec.
Synchronous				Typical Field Current		
Direct	X _d	2.969	1.328	Full Load	I _{fFL}	21.6 amps
Quadrature	X _q	1.523	0.681	No Load	I _{fNL}	5.6 amps
Transient				Typical Short Circuit Ratio		0.337
Unsaturated	X' _{du}	0.292	0.131	Harmonic Distortion		
Saturated	X' _d	0.257	0.115	RMS Total Harmonic Distortion		3.20%
Subtransient				Max. Single Harmonic		5th
Direct	X'' _d	0.123	0.055	Deviation Factor (No Load, L-L)		<5%
Quadrature	X'' _q	0.114	0.051	Telephone Influence Factor		<50
Negative Sequence	X ₂	0.118	0.053	Insulation Class		
Zero Sequence	X ₀	0.011	0.005	per NEMA MG1-1.66		H
				Phase Rotation		ABC

**4R9X, 60 Hz, 139/240, 277/480 Volts, Wye
TYPICAL ALTERNATOR EFFICIENCY***

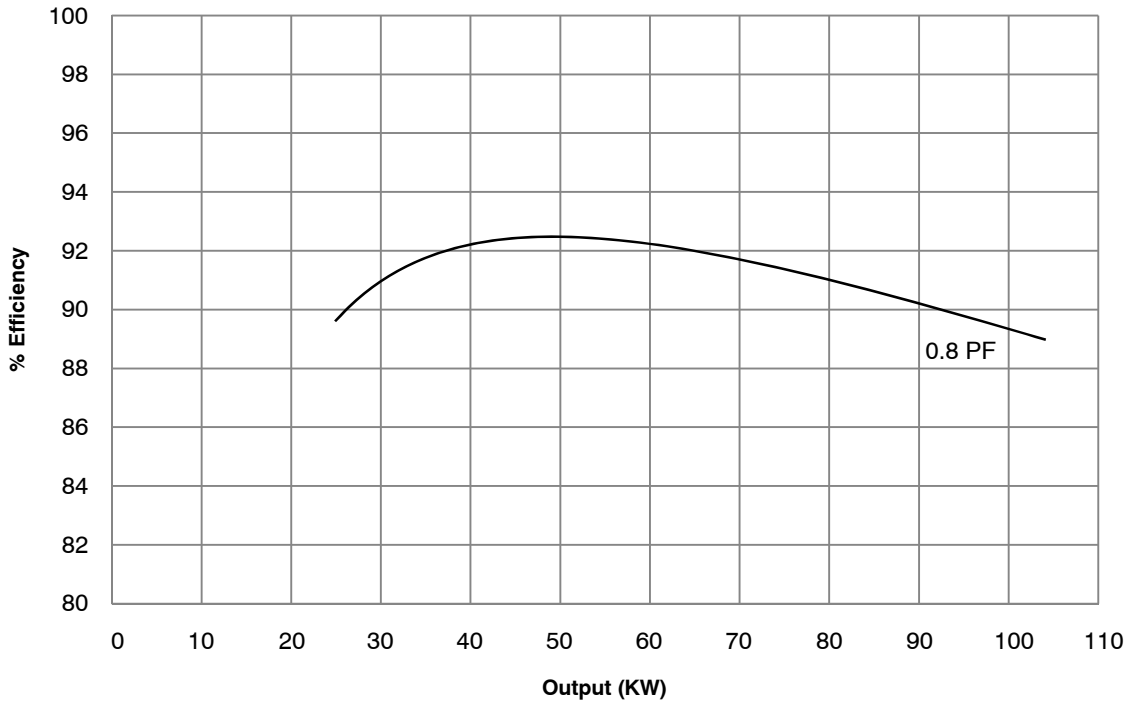

**4R9X, 60 Hz, 139/240, 277/480 Volts, Wye
TYPICAL MOTOR STARTING CHARACTERISTICS***

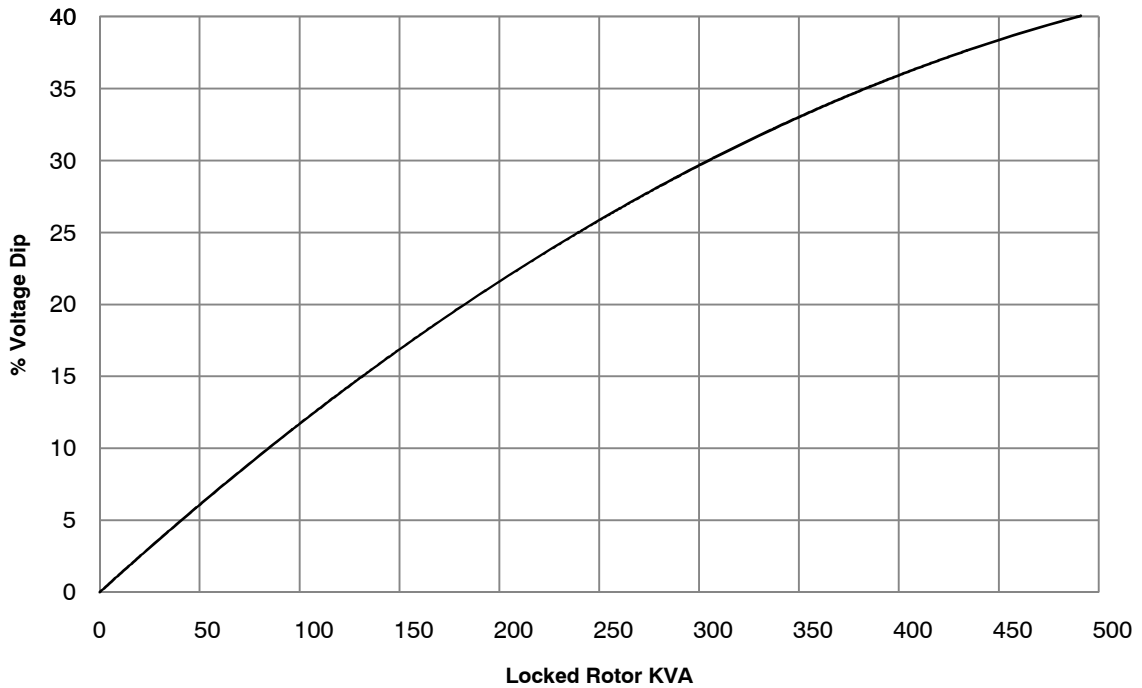

* All data tested in accordance with IEEE Standard 115. Kohler Co. reserves the right to change the design or specifications without notice and without any obligation or liability whatsoever.

**4R9X, 60 Hz, Low Wye or Delta Connection
SHORT CIRCUIT DECREMENT CURVE**

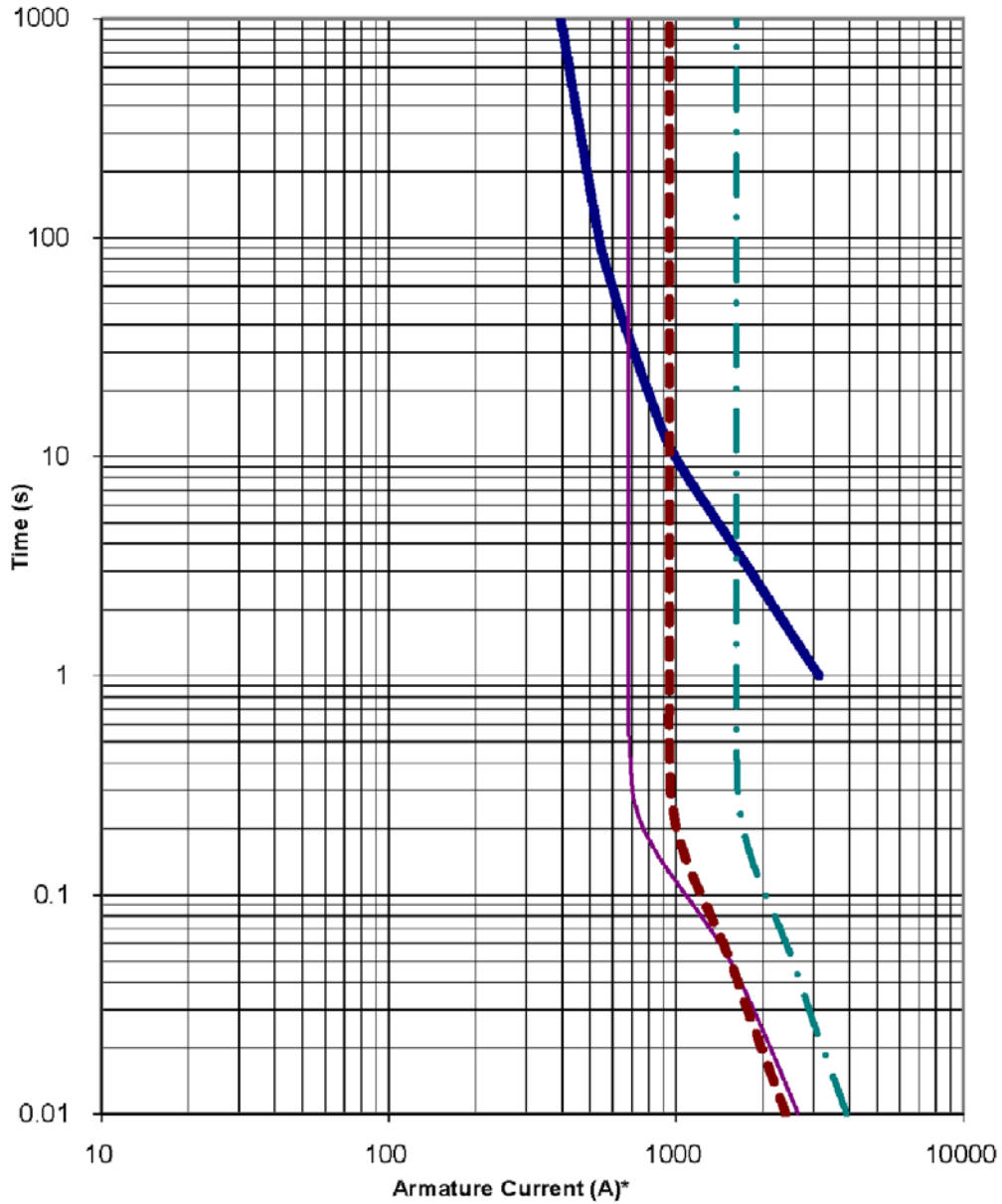

*Instantaneous current (t=0) is asymmetric. Divide by 1.73 for symmetric.

**4R9X, 60 Hz, High Wye Connection
SHORT CIRCUIT DECREMENT CURVE**

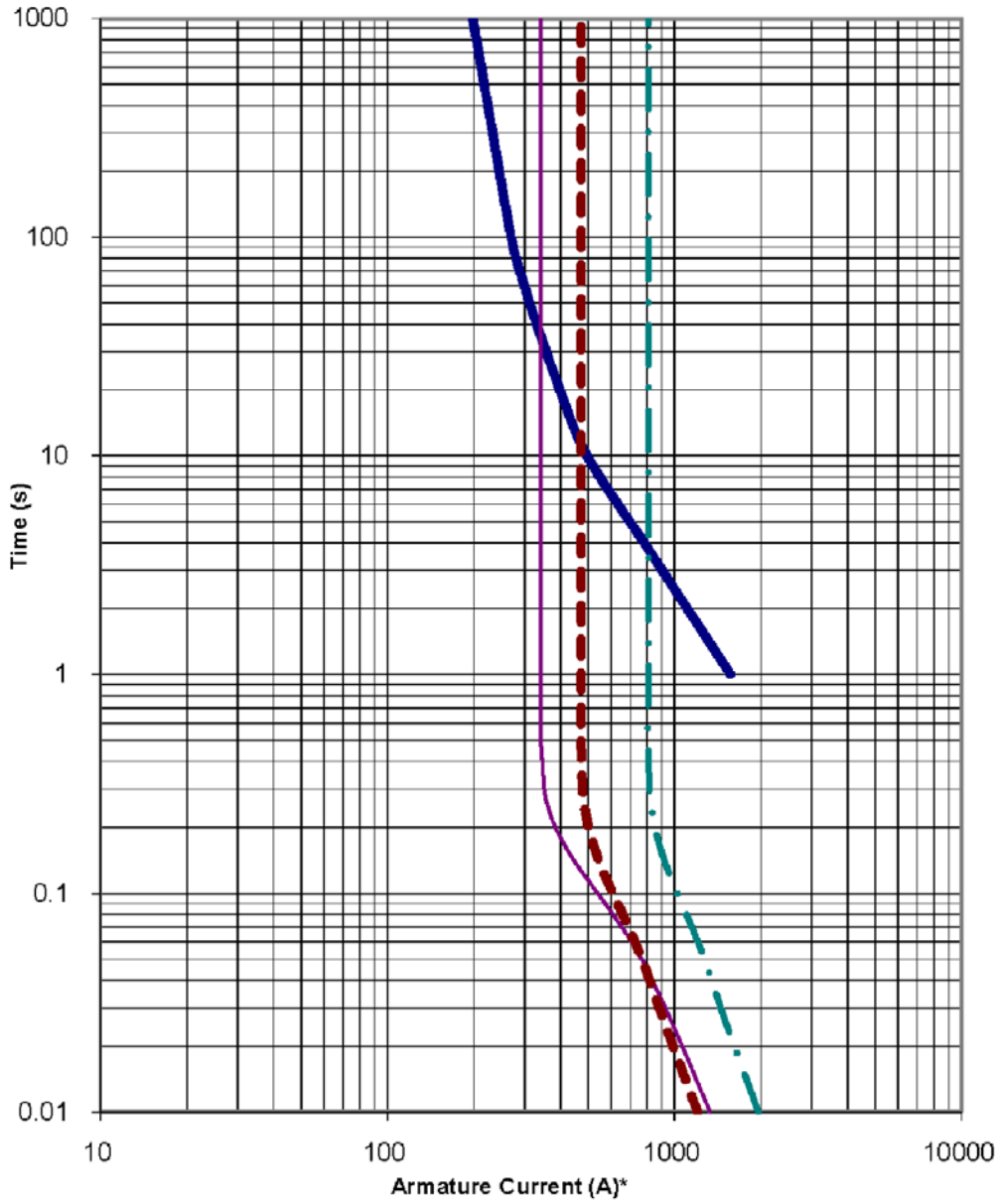

*Instantaneous current (t=0) is asymmetric. Divide by 1.73 for symmetric.

KOHLER®

Cooling Data

TECHNICAL INFORMATION BULLETIN

Generator Set Cooling System Data Sheet

100REOZJF 60Hz (Standby Duty)	50°C Ambient Temperature Cooling System								
	Total external restriction on open unit⁷	Pa <i>(in. H₂O)</i>	0 (0)	125 (0.5)	187 (0.75)	250 (1)	312 (1.25)	375 (1.5)	Enclosed Units
	Maximum allowable ambient temperature	°C <i>(°F)</i>	50 (122)	47 (117)	44 (111)	43 (109)	41 (106)	NA (NA)	45 (113)
	Cooling system airflow	m ³ /min <i>(ft³/min)</i>	142 (5000)	133 (4700)	127 (4500)	121 (4300)	115 (4100)	NA (NA)	NA (NA)

1. The data shown above is the anticipated cooling performance for a typical generator set when following proper installation techniques.
2. Cooling performance is based on operation at 100 m (328 ft.) above sea level. For elevations higher than 100 m (328 ft.), typical cooling performance derate is 1°C (1.8°F) per 250 m (820 ft.).
3. For high ambient conditions, check TIB-101 for the generator set power output derate schedule.
4. Incorrect installation, improper operation, fouling of the cooling system, and other variable conditions may reduce cooling performance.
5. Kohler manufactured sound enclosed models are rated in free air with no additional restriction. Consult factory for other variants or conditions such as additional ducting or hoods.
6. Performance is based on a 50/50 water and ethylene glycol mixture.
7. Total external restriction includes restriction upstream and downstream of the unit – any ducting supplying intake air to the unit and any ducting for the discharge.

KOHLER®

Sound Data

TECHNICAL INFORMATION BULLETIN

Generator Set Sound Data Sheet

			Sound Pressure Data in dB(A)				
Generator Set Model	Hz	Load	Raw Exhaust	Open Unit, Isolated Exhaust	Weather Enclosure	Sound Enclosure	
100REOZJF	60	100% Load	112.4	84.5	82.6	69.8	
		No Load	100.1	80.9	79.0	68.3	

Note: Sound pressure data is the logarithmic average of eight perimeter measurement points at a distance of 7 m (23 ft.), except Raw Exhaust data which is a single measurement point at 1 m (3.3 ft.) from the mouth of a straight pipe exhaust.

			Sound Pressure Levels, dB(A)									
Load	Distance, m (ft)	Enclosure	Measurement Clock Position	Octave Band Center Frequency (Hz)								Overall Level
				63	125	250	500	1000	2000	4000	8000	
100% Load	7 (23)	Sound	3:00	41.6	61.3	61.7	63.5	59.3	59.1	56.7	52.6	68.7
			1:30	45.4	59.1	63.1	66.1	63.0	60.4	60.7	54.8	70.6
			12:00-Engine	48.2	59.0	61.5	66.2	62.5	62.9	62.6	57.8	71.0
			10:30	48.9	60.3	63.5	66.3	62.6	60.9	60.6	56.5	70.9
			9:00	46.6	59.4	62.8	63.7	59.8	60.2	59.0	56.3	69.3
			7:30	44.7	59.2	63.6	63.0	60.9	60.6	60.6	58.2	69.8
			6:00-Alternator	49.9	56.7	59.6	64.1	60.0	60.2	58.8	55.0	68.6
			4:30	48.7	55.8	60.6	62.9	61.3	59.8	59.0	54.2	68.4
		8-pos. log avg.	47.4	59.1	62.2	64.7	61.4	60.6	60.1	56.0	69.8	

			Sound Pressure Levels, dB(A)									
Load	Distance, m (ft)	Enclosure	Measurement Clock Position	Octave Band Center Frequency (Hz)								Overall Level
				63	125	250	500	1000	2000	4000	8000	
No Load	7 (23)	Sound	3:00	47.9	60.0	62.0	62.3	57.8	55.4	50.1	41.6	67.3
			1:30	51.0	58.7	63.3	65.7	62.2	57.0	55.9	43.5	69.7
			12:00-Engine	52.5	58.2	61.1	65.7	61.4	59.9	59.0	47.0	69.6
			10:30	51.9	60.0	63.9	65.4	61.5	56.2	55.0	44.4	69.7
			9:00	49.7	58.3	63.1	62.2	57.2	54.9	51.0	42.7	67.4
			7:30	42.6	60.4	65.1	61.0	58.4	55.8	50.1	42.5	68.3
			6:00-Alternator	46.8	54.3	58.4	62.8	57.5	53.8	50.2	38.5	65.9
			4:30	44.6	55.8	61.1	61.3	59.8	56.1	50.4	40.2	66.6
		8-pos. log avg.	49.5	58.6	62.6	63.7	59.9	56.5	54.1	43.2	68.3	

KOHLER®

Exhaust System Data

TECHNICAL INFORMATION BULLETIN

Enclosed Generator Set Exhaust System Data Sheet

Model	Enclosure Type	Consumed Back Pressure (in H2O)	Consumed Back Pressure (in Hg)	Back Pressure Limit(s) (in H2O)	Back Pressure Limit(s) (in Hg)	Flex Exhaust Tube(s)	Silencer	Drawing
100REOZJF	All Weather & Sound Enclosures & Snow Package Enclosure	28.7	2.1	30.0	2.2	GM66733	GM59117	ADV-7647

1. Total system exhaust back pressure is applicable to generator sets equipped with Kohler standard enclosure packages.
2. For generator sets with multiple exhaust outlets, total system exhaust back pressure value represents each outlet.
3. The total system back pressure should not exceed the manufacturer's recommended limit.
4. The total back pressure only includes exhaust components installed inside the Kohler enclosure. Customers must calculate any additional back pressure caused by piping, extensions, or components added after the silencer outlet. Refer to the installation manual for additional details.

KOHLER®

Emissions Data



100REOZJF

60 HZ. DIESEL INDUSTRIAL GENERATOR SET EMISSION DATA SHEET

ENGINE INFORMATION			
Model:	John Deere, 4045HF285I	Bore:	106mm (4.19 in.)
Nameplate BHP @ 1800 RPM:	158	Stroke:	127mm (5.0 in.)
Type:	4-Cycle, 4 Cylinder, Inline	Displacement:	4.5 L (276 cu. in.)
Aspiration:	Turbocharged, Charge Air-Cooled	EPA Family:	PJDXL04.5119
Compression Ratio	19.0:1	EPA Certificate:	PJDXL04.5119-008

PERFORMANCE DATA:	Table 1			
	1/4 Standby	1/2 Standby	3/4 Standby	Full Standby
Engine bkW @ Stated Load	30	59	89	118
Fuel Consumption (g/kWh)	272	255	237	222
Exhaust Gas Flow (m ³ /min)				23
Exhaust Temperature (°C)				580

EXHAUST EMISSION DATA:	Table 2 EPA D2 Cycle 5-mode weighted	
	HC (Total Unburned Hydrocarbons)	0.15
NOx (Oxides of Nitrogen as NO ₂)	3.36	
CO (Carbon Monoxide)	1.3	
PM (Particulate Matter)	0.17	

Values are in g/kWh unless otherwise noted

TEST METHODS AND CONDITIONS

The emission data listed is measured from a laboratory test engine according to the test procedures of 40 CFR 89 or 40 CFR 1039, as applicable. The test engine is intended to represent nominal production hardware, and there is no guarantee that every production engine will have identical test results. The family parent data represents multiple ratings and this data may have been collected at a different engine speed and load. Emission results may vary due to engine manufacturing tolerances, engine operating conditions, fuels used, alternate test methods, or other conditions.

Data and specifications subject to change without notice.



**UNITED STATES ENVIRONMENTAL PROTECTION AGENCY
2023 MODEL YEAR
CERTIFICATE OF CONFORMITY
WITH THE CLEAN AIR ACT**

**OFFICE OF TRANSPORTATION
AND AIR QUALITY
ANN ARBOR, MICHIGAN 48105**

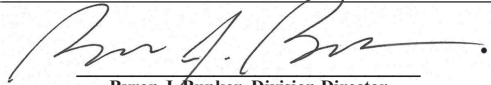
Certificate Issued To: Deere & Company (U.S. Manufacturer or Importer) Certificate Number: PJDXL04.5119-008	<u>Effective Date:</u> 06/16/2022 <u>Expiration Date:</u> 12/31/2023	 <hr/> Byron J. Bunker, Division Director Compliance Division	<u>Issue Date:</u> 06/16/2022 <u>Revision Date:</u> N/A
---	---	---	--

Model Year: 2023 Manufacturer Type: Original Engine Manufacturer Engine Family: PJDXL04.5119	Mobile/Stationary Indicator: Stationary Emissions Power Category: 75<=kW<130 Fuel Type: Diesel After Treatment Devices: No After Treatment Devices Installed Non-after Treatment Devices: Electronic Control, Smoke Puff Limiter, Non-standard Non-After Treatment Device Installed, Engine Design Modification
---	--

Pursuant to Section 111 and Section 213 of the Clean Air Act (42 U.S.C. sections 7411 and 7547) and 40 CFR Part 60, and subject to the terms and conditions prescribed in those provisions, this certificate of conformity is hereby issued with respect to the test engines which have been found to conform to applicable requirements and which represent the following engines, by engine family, more fully described in the documentation required by 40 CFR Part 60 and produced in the stated model year.

This certificate of conformity covers only those new compression-ignition engines which conform in all material respects to the design specifications that applied to those engines described in the documentation required by 40 CFR Part 60 and which are produced during the model year stated on this certificate of the said manufacturer, as defined in 40 CFR Part 60.

It is a term of this certificate that the manufacturer shall consent to all inspections described in 40 CFR 1068 and authorized in a warrant or court order. Failure to comply with the requirements of such a warrant or court order may lead to revocation or suspension of this certificate for reasons specified in 40 CFR Part 60. It is also a term of this certificate that this certificate may be revoked or suspended or rendered void *ab initio* for other reasons specified in 40 CFR Part 60.

This certificate does not cover engines sold, offered for sale, or introduced, or delivered for introduction, into commerce in the U.S. prior to the effective date of the certificate.

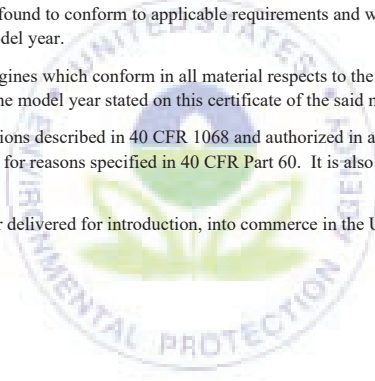

KOHLER®

Dimensional Drawings

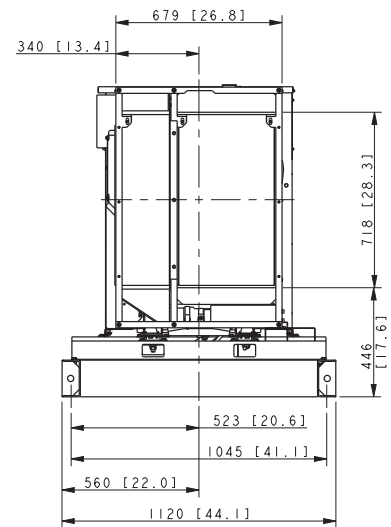
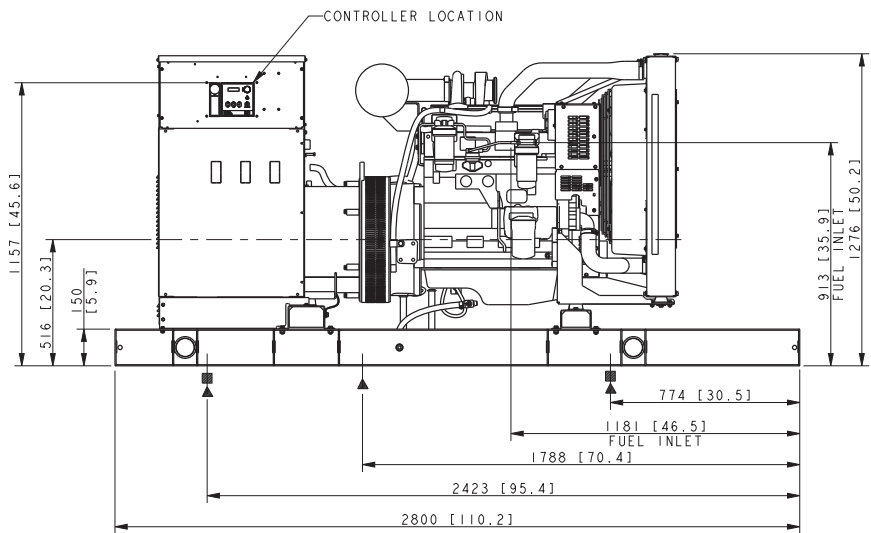

FOR ENCLOSED GENSETS
 80RE0ZJF MODEL, 4P10X, 4R9X, 4T9X
 100RE0ZJF MODEL, 4R9X, 4R12X, 4T12X
 RECONNECTABLE
 IMPROVE MOTOR STARTING (IMS) RECONNECTABLE
 600V & 1 PHASE ALTERNATORS
 4045HF285 JOHN DEERE, TIER III

REV	DATE	ON COMPOSITE DWGS. SEE PART NO. FOR REVISION LEVEL	BY	UNLESS OTHERWISE SPECIFIED: 2) DIMENSIONS ARE IN MILLIMETERS
-	5-12-11	NEW DRAWING (91379-4)	KMP	2) TOLERANCES ARE: F - XX ± 0.25 Z - F ± 1.5
A	10AUG2021 (B-8)	1157 ADDED; SEE SHEET 1 [CT213944]	SSS	3) SURFACE FINISH ANGLES ± 0° 30' / MAX.
				4) HIDE ANGLE PROJECTION
				APPROVALS
				DATE
				5-12-11
				5-12-11
				5-12-11

KOHLER CO. METRIC PRO-E
 POWER SYSTEMS, KOHLER, WI 53044 U.S.A.
 THIS DRAWING IN DESIGN AND DETAIL IS KOHLER CO. PROPERTY AND MUST NOT BE USED EXCEPT IN CONNECTION WITH KOHLER CO. WORK. ALL RIGHTS OF DESIGN OR INVENTION ARE RESERVED.

TITLE: **DIMENSION PRINT 80-100 MODEL**

SCALE: 0.10 CAD NO. SHEET 2 of 4
 DWG NO. **ADV-8181**

8 7 6 5 4 3 2 1

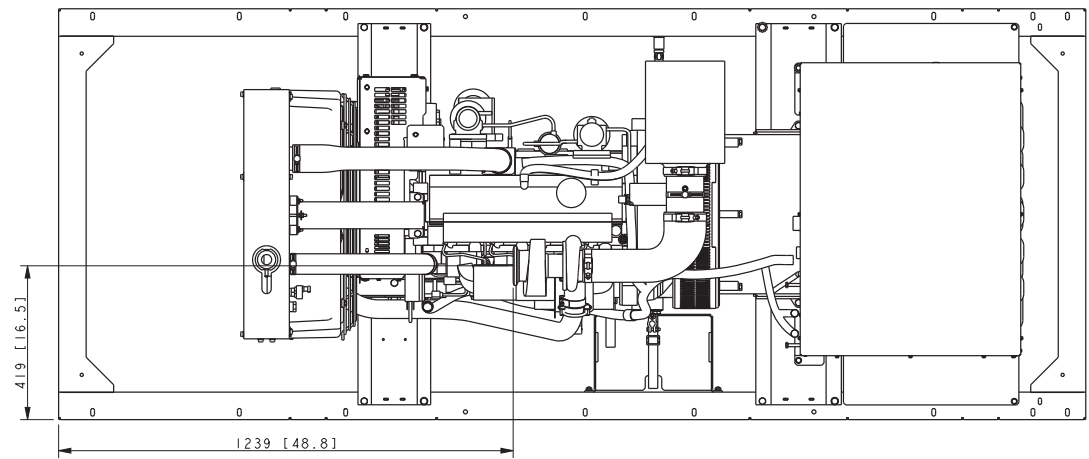

ENGINE EXHAUST OUTLET
SEE DETAIL A SHEET 3

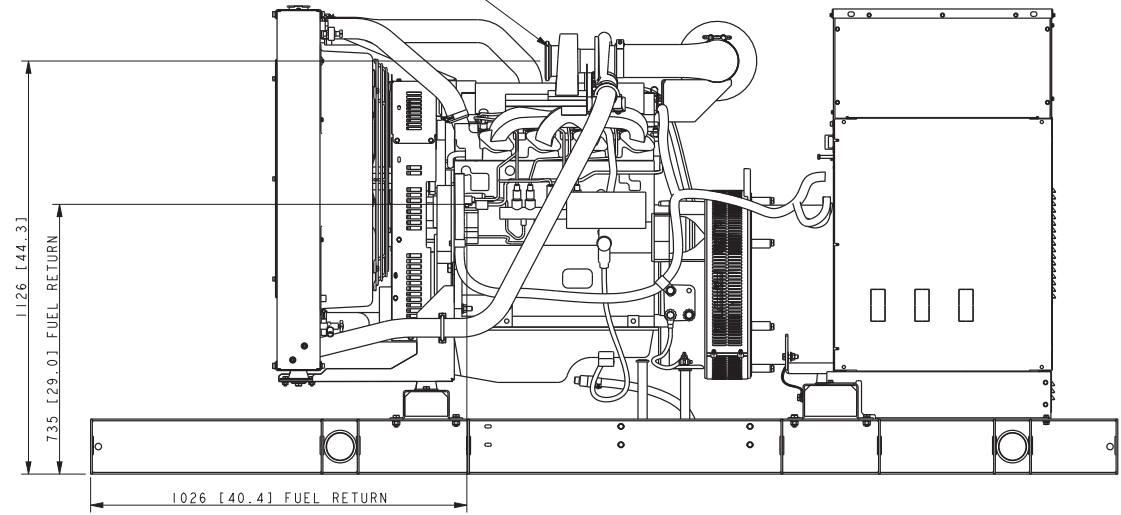

REV	DATE	ON COMPOSITE DWGS. SEE PART NO. FOR REVISION LEVEL	BY	UNLESS OTHERWISE SPECIFIED:	SCALE	TITLE
-	5-19-11	NEW DRAWING (91379-4)	KMP	17 DIMENSIONS ARE IN MILLIMETERS	0.15	DIMENSION PRINT 80-100 MODEL
A	10AUG2021	SEE SHEET 1 & 2 [CT213944]	SSS	27 TOLERANCES ARE: 2-XX ± 0.25 2-F ± 1.5 ANGLES ± 0° 30' / MAX.		
				THIRD ANGLE PROJECTION		
				APPROVALS		
				DATE		
				DRWN		
				CHKD		
				APPRVD		

FOR ENCLOSED GENSETS
80RE0ZJF MODEL, 4P10X, 4R9X, 4T9X
100RE0ZJF MODEL, 4R9X, 4R12X, 4T12X
FUEL RETURN AND EXHAUST
LOCATION WITH 44 IN. SKID

KOHLER CO. METRIC PRO-E
POWER SYSTEMS, KOHLER, WI 53044 U.S.A.
THIS DRAWING IN DESIGN AND DETAIL IS KOHLER CO. PROPERTY AND MUST NOT BE USED EXCEPT IN CONNECTION WITH KOHLER CO. WORK. ALL RIGHTS OF DESIGN OR INVENTION ARE RESERVED.

SCALE 0.15 CAD NO. SHEET 4 of 4
Dwg No. **ADV-8181**

8 7 6 5 4 3 2 1

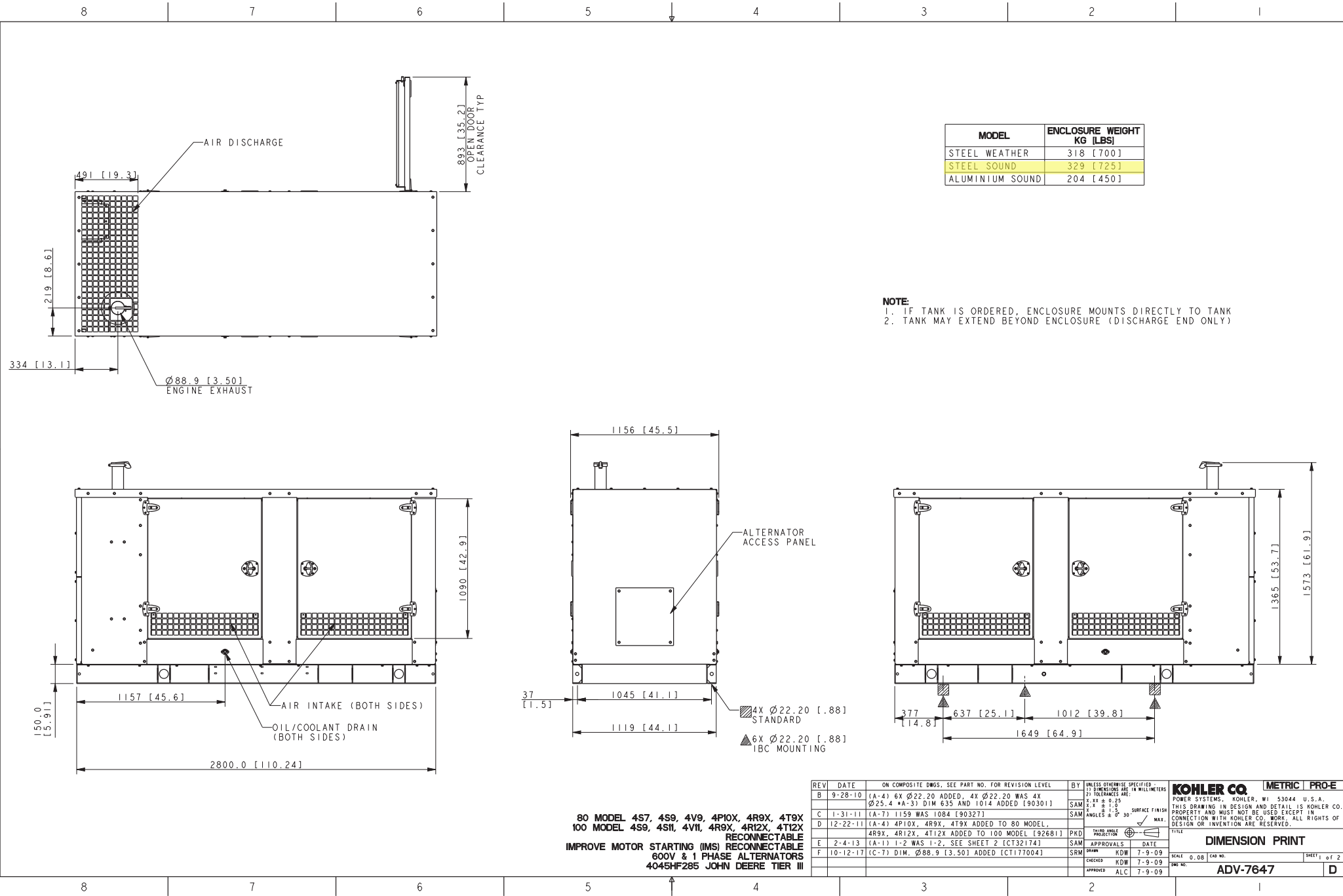

MODEL	ENCLOSURE WEIGHT KG [LBS]
STEEL WEATHER	318 [700]
STEEL SOUND	329 [725]
ALUMINIUM SOUND	204 [450]

NOTE:
 1. IF TANK IS ORDERED, ENCLOSURE MOUNTS DIRECTLY TO TANK
 2. TANK MAY EXTEND BEYOND ENCLOSURE (DISCHARGE END ONLY)

80 MODEL 4S7, 4S9, 4V9, 4P10X, 4R9X, 4T9X
 100 MODEL 4S9, 4S11, 4V11, 4R9X, 4R12X, 4T12X
 RECONNECTABLE
 IMPROVE MOTOR STARTING (IMS)
 600V & 1 PHASE ALTERNATORS
 4045HF285 JOHN DEERE TIER III

REV	DATE	ON COMPOSITE DWGS. SEE PART NO. FOR REVISION LEVEL	BY	UNLESS OTHERWISE SPECIFIED: 2) DIMENSIONS ARE IN MILLIMETERS 2) TOLERANCES ARE: 2-1X ± 0.25 2-12 ± 0.15 ANGLES ± 0° 30' / MAX.	TITLE
B	9-28-10	(A-4) 6X Ø22.20 ADDED, 4X Ø22.20 WAS 4X Ø25.4 *A-3) DIM 635 AND 1014 ADDED [90301]	SAM		KOHLER CO. METRIC PRO-E POWER SYSTEMS, KOHLER, WI 53044 U.S.A. THIS DRAWING IN DESIGN AND DETAIL IS KOHLER CO. PROPERTY AND MUST NOT BE USED EXCEPT IN CONNECTION WITH KOHLER CO. WORK. ALL RIGHTS OF DESIGN OR INVENTION ARE RESERVED. DIMENSION PRINT SCALE 0.08 CAD NO. SHEET 1 of 2 TAG NO. ADV-7647
C	1-31-11	(A-7) 1159 WAS 1084 [90327]	SAM		
D	12-22-11	(A-4) 4P10X, 4R9X, 4T9X ADDED TO 80 MODEL, 4R9X, 4R12X, 4T12X ADDED TO 100 MODEL [92681]	PKD		
E	2-4-13	(A-1) 1-2 WAS 1-2, SEE SHEET 2 [CT32174]	SAM	APPROVALS DATE	
F	10-12-17	(C-7) DIM. Ø88.9 [3.50] ADDED [CT177004]	SRM	CHK'D DATE	
			APPROVED	DATE	

MODEL	CAPACITY		WEIGHT		HEIGHT	
	LITERS	GAL	KG	LBS	MM	IN
80/100kW	815	215	595	1312	431.8	17.0
80/100kW	1570	415	835	1840	762.0	30.0

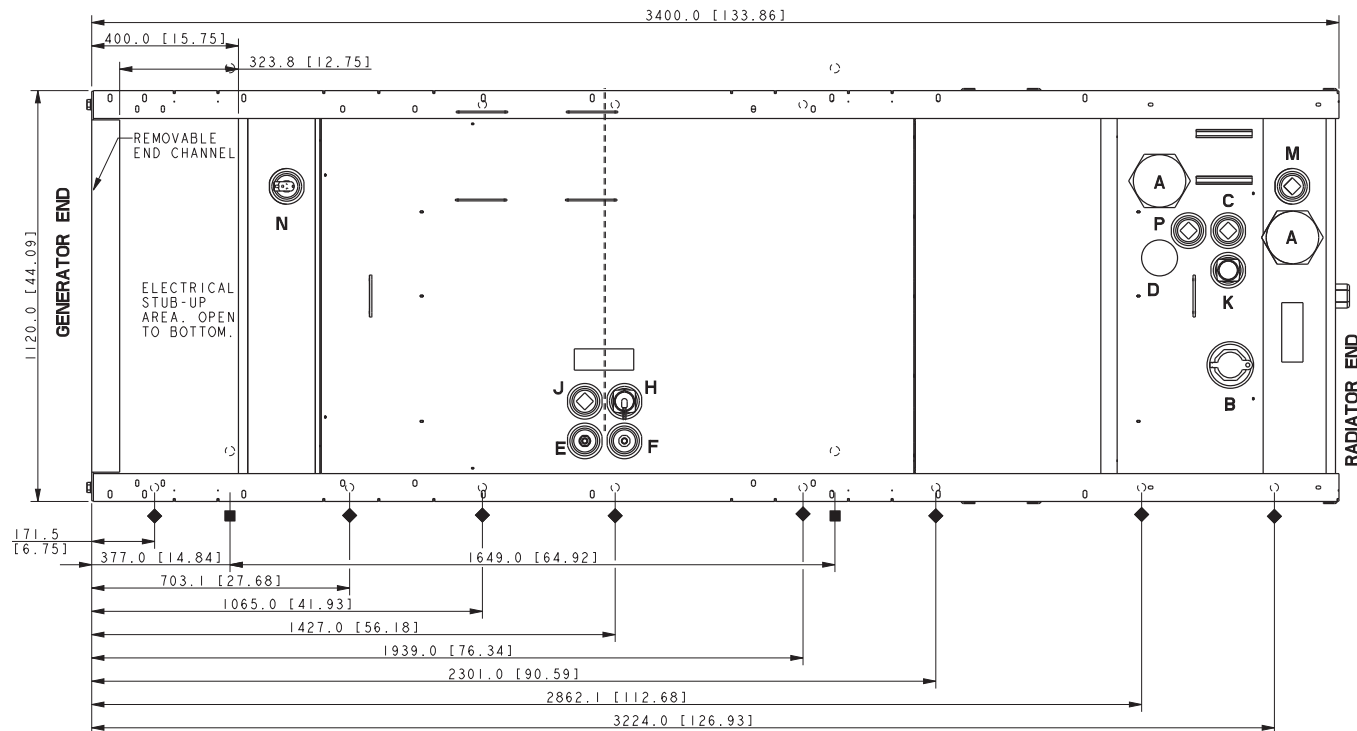

TANK FITTINGS:

- A. 4" NPT EMERGENCY VENT FITTING PER NFPA 30 WITH VENT CAPS (QTY 2)
- B. 2" NPT FUEL FILL FITTING WITH LOCKABLE CAP & 2" RISER (INSTALL STEEL 2" NPT PIPE PLUG)
- C. 2" NPT ADDITIONAL FITTING FOR OPTIONAL ACCESSORY (INSTALL STEEL 2" NPT PIPE PLUG)
- D. 2" NORMAL VENT FITTING WITH MUSHROOM VENT CAP AND 5" RISER
- E. 2" NPT FITTING FOR REMOVABLE ENGINE SUPPLY DIP TUBE (3/8" NPT FEMALE WITH CHECK VALVE)
- F. 2" NPT FITTING FOR REMOVABLE FUEL RETURN DIP TUBE (3/8" NPT FEMALE)
- H. 2" NPT FUEL LEVEL SENDING UNIT (INSTALL STEEL 2" NPT PIPE PLUG)
- J. 2" NPT ADDITIONAL FITTING FOR OPTIONAL ACCESSORY (INSTALL STEEL 2" NPT PIPE PLUG)
- K. 2" FUEL LEVEL GAUGE FITTING W/DIRECT READING MECHANICAL GAUGE
- M. 2" NPT BASIN DRAIN (INSTALL STEEL 2" NPT PIPE PLUG)
- N. 2" NPT FOR FUEL IN BASIN SWITCH (INSTALL STEEL 2" NPT PIPE PLUG)
- P. 2" NPT ADDITIONAL FITTING FOR OPTIONAL ACCESSORY (INSTALL STEEL 2" PIPE PLUG)

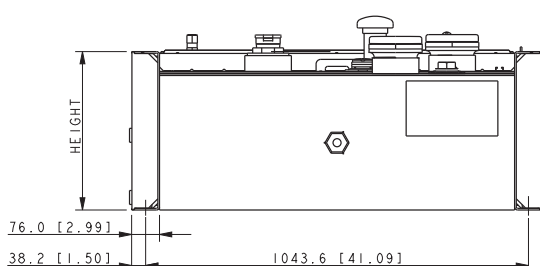
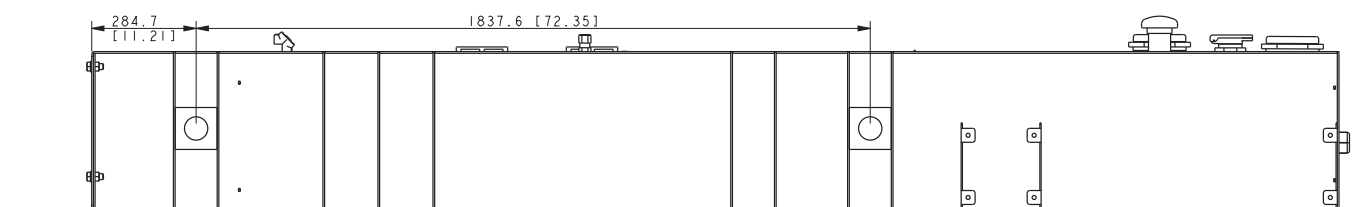

NOTE:
FOR FURTHER TANK DETAIL
SEE INDIVIDUAL DRAWINGS

■ 4X Ø25.4 [1.00]
STANDARD MOUNTING

◆ 16X Ø22.2 [0.875]
IBC MOUNTING

STATE TANK

80 MODEL 4S7, 4S9, 4V9, 4P10X, 4R9X, 4T9X
100 MODEL 4S9, 4S11, 4V11, 4R9X, 4R12X, 4T12X
RECONNECTABLE
IMPROVE MOTOR STARTING (IMS) RECONNECTABLE
600V & 1 PHASE ALTERNATORS
4045HF285 JOHN DEERE, TIER III

REV	DATE	ON COMPOSITE DWGS. SEE PART NO. FOR REVISION LEVEL	BY	UNLESS OTHERWISE SPECIFIED: DIMENSIONS ARE IN MILLIMETERS TOLERANCES ARE: F. XX ± 0.25 F. F ± 0.15 SURFACE FINISH ANGLES ± 0° 30' / MAX.
-	9-12-12	NEW DRAWING [CT23454]	JB2	
A	1-25-18	(D-2) FITTING NOTES M & N 2" NPT WAS 1/2" NPT.	JB2	
B	2-22-18	SEE SHEET 2 [CT182424]	PAS	
C	12-5-19	SEE SHEET 2 [CT200428]	YBY	
APPROVALS				DATE
DRAWN				9-12-12
CHECKED				9-12-12
APPROVED				9-12-12

KOHLER CO. METRIC PRO-E
POWER SYSTEMS, KOHLER, WI 53044 U.S.A.
THIS DRAWING IN DESIGN AND DETAIL IS KOHLER CO. PROPERTY AND MUST NOT BE USED EXCEPT IN CONNECTION WITH KOHLER CO. WORK. ALL RIGHTS OF DESIGN OR INVENTION ARE RESERVED.

TITLE: **DIMENSION PRINT, SUBBASE TANK, STATE**

SCALE: 0.15 CAD NO. SHEET 1 of 2

DWG NO: **ADV-8522**

KOHLER®

Wiring Schematics

REV	DATE	REVISION	BY
A	10-11-18	SEE SHEET 2 (CT191090)	TJL
B	2-05-19	SEE SHEETS 10 & 11 (CT193517)	SMH
C	3-18-19	(A-1, -2) CHART UPDATED FOR SPEED AND VOLTAGE BIAS; SEE SHEET 2 (CT194009)	SMH
D	5-13-19	(A, B, C-1) TB12-19 THRU 44 ADDED, WOKED VOLTAGE AND SPEED BIAS ON TB12; SEE SHEET 2 (CT195241)	TEV
E	9-10-19	SEE SHEET 2 (CT195508)	TEV

REV	DATE	REVISION	BY
A	10-11-18	SEE SHEET 2 (CT191090)	TJL
B	2-05-19	SEE SHEETS 10 & 11 (CT193517)	SMH
C	3-18-19	(A-1, -2) CHART UPDATED FOR SPEED AND VOLTAGE BIAS; SEE SHEET 2 (CT194009)	SMH
D	5-13-19	(A, B, C-1) TB12-19 THRU 44 ADDED, WOKED VOLTAGE AND SPEED BIAS ON TB12; SEE SHEET 2 (CT195241)	TEV
E	9-10-19	SEE SHEET 2 (CT195508)	TEV

REV	DATE	REVISION	BY
A	10-11-18	SEE SHEET 2 (CT191090)	TJL
B	2-05-19	SEE SHEETS 10 & 11 (CT193517)	SMH
C	3-18-19	(A-1, -2) CHART UPDATED FOR SPEED AND VOLTAGE BIAS; SEE SHEET 2 (CT194009)	SMH
D	5-13-19	(A, B, C-1) TB12-19 THRU 44 ADDED, WOKED VOLTAGE AND SPEED BIAS ON TB12; SEE SHEET 2 (CT195241)	TEV
E	9-10-19	SEE SHEET 2 (CT195508)	TEV

REV	DATE	REVISION	BY
A	10-11-18	SEE SHEET 2 (CT191090)	TJL
B	2-05-19	SEE SHEETS 10 & 11 (CT193517)	SMH
C	3-18-19	(A-1, -2) CHART UPDATED FOR SPEED AND VOLTAGE BIAS; SEE SHEET 2 (CT194009)	SMH
D	5-13-19	(A, B, C-1) TB12-19 THRU 44 ADDED, WOKED VOLTAGE AND SPEED BIAS ON TB12; SEE SHEET 2 (CT195241)	TEV
E	9-10-19	SEE SHEET 2 (CT195508)	TEV

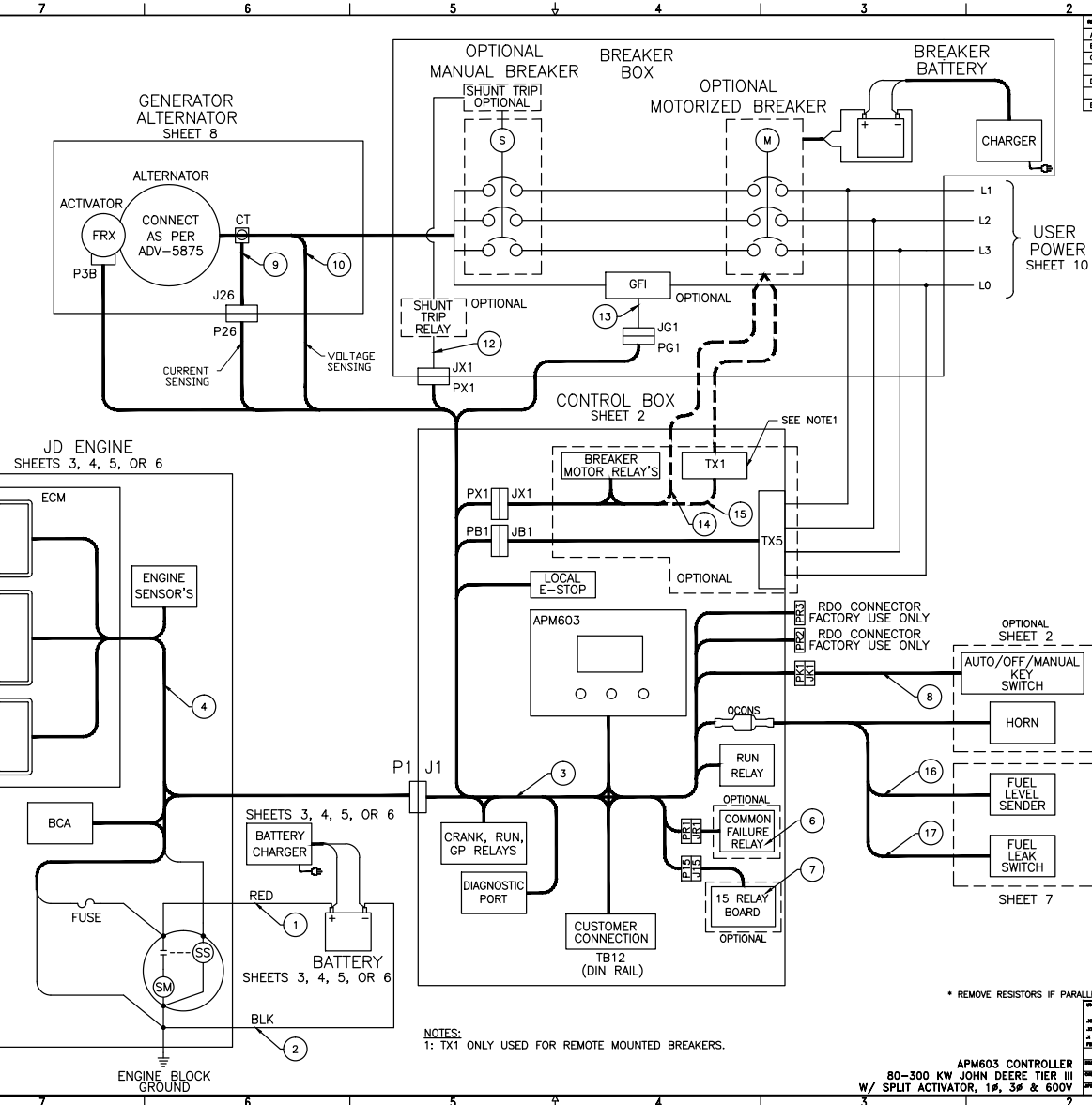

FUNCTION	POS	SIGNAL DESCRIPTION
REMOTE E-STOP	1	REMOTE EMERGENCY STOP
REMOTE START	2	REMOTE START SIGNAL
CUSTOMER INTERFACE	5	FUSED BATTERY POWER
CUSTOMER INTERFACE	6	BAIT VOLTS WHEN RUNNING
CUSTOMER INTERFACE	7	BATTERY NEGATIVE
CUSTOMER INTERFACE	8	A (-) ISOLATED
CUSTOMER INTERFACE	9	B (+) RS-485 #2 (MODBUS/PGEN)
CUSTOMER INTERFACE	10	SHIELD
RES IN RETURN	11	LOW FUEL LEVEL SWITCH
RES IN RETURN	12	LOW FUEL LEVEL SWITCH RETURN
BAT CHRG FLT	13	BATTERY CHARGER FAULT
RES IN RETURN	14	BATTERY CHARGER FAULT RETURN
AUX WARNING	15	AUXILIARY WARNING
RES IN RETURN	16	AUXILIARY WARNING RETURN
AUX FAULT	17	AUXILIARY FAULT
RES IN RETURN	18	AUXILIARY FAULT RETURN
CUSTOMER INTERFACE	19	A (-) ISOLATED
CUSTOMER INTERFACE	20	B (+) RS-485 #3 (MODBUS/PGEN)
CUSTOMER INTERFACE	21	SHIELD
CUSTOMER INTERFACE	22	A (-) NON-ISOLATED
CUSTOMER INTERFACE	23	B (+) RS-485 #4 (MODBUS RSA)
CUSTOMER INTERFACE	24	SHIELD
RUN RELAY	25	COMMON CONTACT
RUN RELAY	26	NORMALLY OPEN CONTACT
RUN RELAY	27	NORMALLY CLOSED CONTACT
SPEED BIAS	28	SPEED BIAS (+)
SPEED BIAS	29	SPEED BIAS (-)
VOLTAGE BIAS	30	SHIELD
VOLTAGE BIAS	31	VOLTAGE BIAS (+)
VOLTAGE BIAS	32	VOLTAGE BIAS (-)
SPARE	33	SHIELD
SPARE	34	SPARE
SPARE	35	SPARE
DROOP SELECT	36	ISOCHRONOUS DROOP
ANALOG THROTTLE CONTROL	37	JP2 IN JP2 OUT +5 VDC REF
SPARE	38	SIGNAL (+2.5 VDC NORM)
SPARE	39	SENSOR RETURN
SPARE	40	CONSULT FACTORY
SPARE	41	SPARE
SPARE	42	SPARE
SPARE	43	SPARE
SPARE	44	SPARE

* REMOVE RESISTORS IF PARALLELING

REV	DATE	REVISION	BY
A	10-11-18	SEE SHEET 2 (CT191090)	TJL
B	2-05-19	SEE SHEETS 10 & 11 (CT193517)	SMH
C	3-18-19	(A-1, -2) CHART UPDATED FOR SPEED AND VOLTAGE BIAS; SEE SHEET 2 (CT194009)	SMH
D	5-13-19	(A, B, C-1) TB12-19 THRU 44 ADDED, WOKED VOLTAGE AND SPEED BIAS ON TB12; SEE SHEET 2 (CT195241)	TEV
E	9-10-19	SEE SHEET 2 (CT195508)	TEV

NOTES:
1: TX1 ONLY USED FOR REMOTE MOUNTED BREAKERS.

APM603 CONTROLLER
80-300 KW JOHN DEERE TIER III
W/ SPLIT ACTIVATOR, 1#, 3# & 600V

ADV-9057

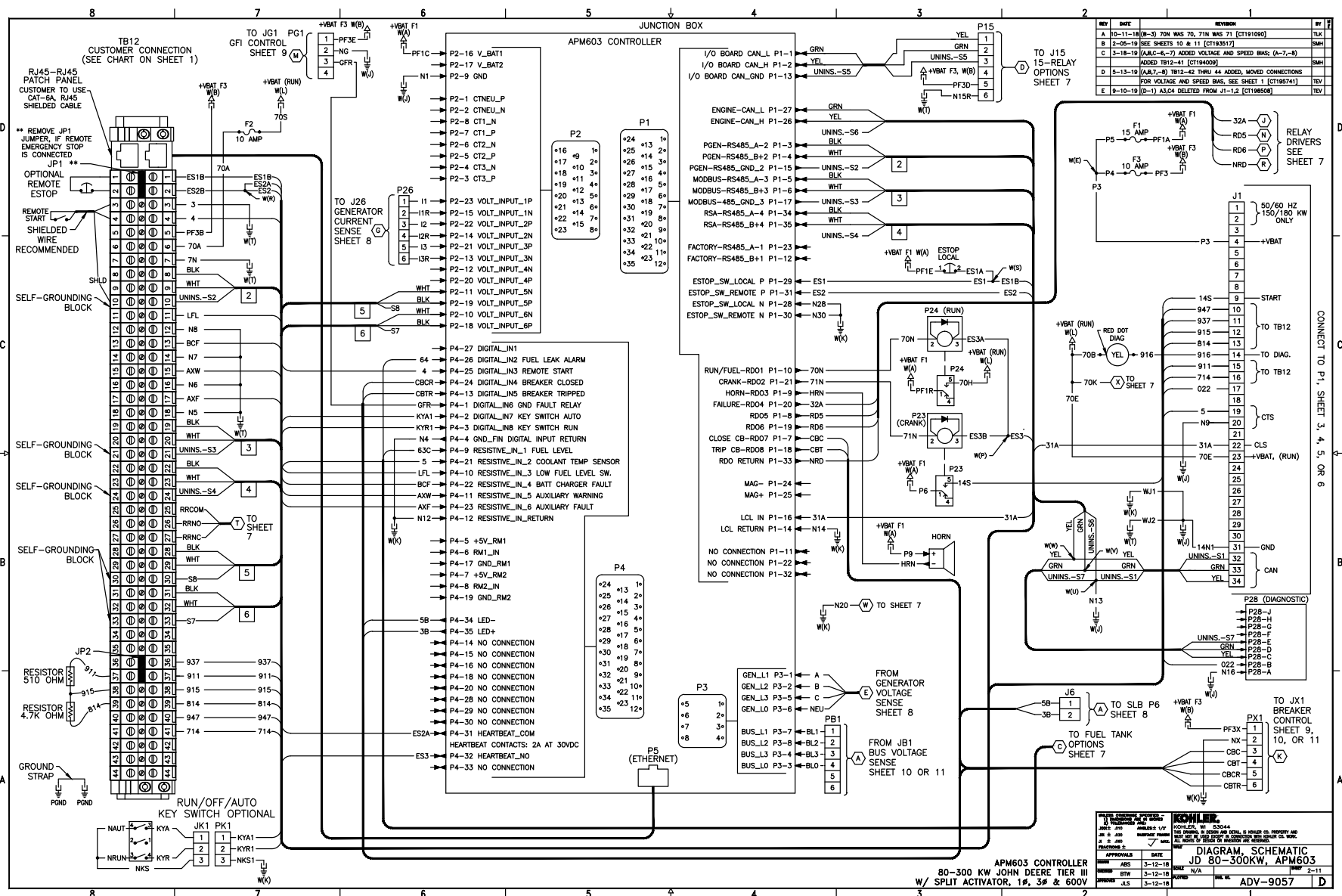

REV	DATE	BY	REVISION
A	10-11-18	(2-3)	70N WAS 70, 71N WAS 71 (C1191990)
B	2-05-19		SEE SHEETS 10 & 11 (C1193817)
C	3-18-19	(A,B,C-6,-7)	ADDED VOLTAGE AND SPEED BAS (A-7,-8) ADDED TB12-41 (C1194000)
D	5-13-19	(A,B,-7,-8)	TB12-42 THRU 44 ADDED, MOVES CONNECTIONS FOR VOLTAGE AND SPEED BAS, SEE SHEET 1 (C1195241)
E	8-10-19	(D-1)	A3,4 DELETED FROM J1-1,2 (C1195508)

APPROVALS	DATE	BY	REVISION
DESIGNED BY	3-12-18	ABS	1
CHECKED BY	3-12-18	BTW	2
APPROVED BY	3-12-18	JLS	3

DIAGRAM, SCHEMATIC
JD 80-300KW, APM603

ENGINE

REV	DATE	REVISION	BY
-	3-12-18	NEW DRAWING [CT190243]	ASB
A	10-11-18	SEE SHEET 2 [CT191090]	TLK
B	2-05-19	SEE SHEETS 10 & 11 [CT193517]	SMH
C	3-18-19	SEE SHEETS 1 & 2 [CT194009]	SMH
D	5-13-19	SEE SHEETS 1 & 2 [CT197471]	TEV
E	9-10-19	SEE SHEET 2 [CT198503]	TEV

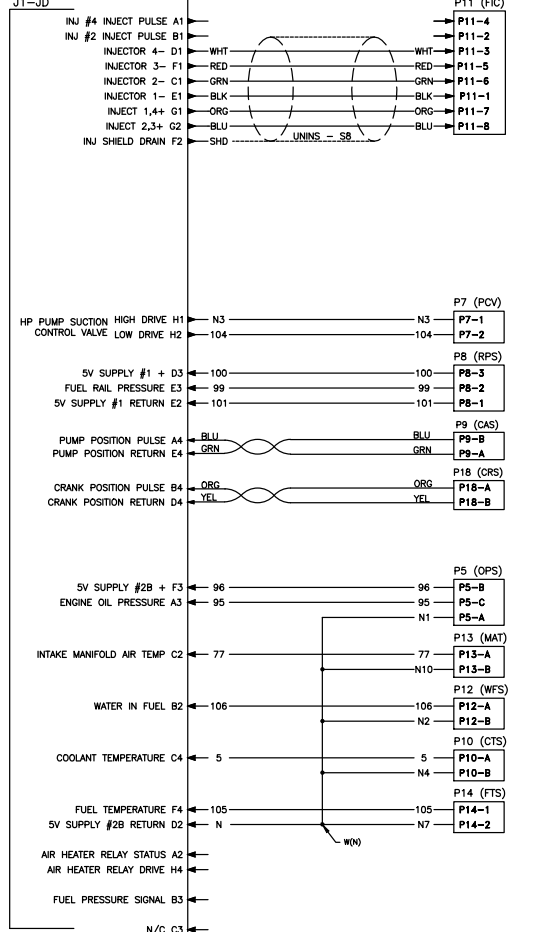
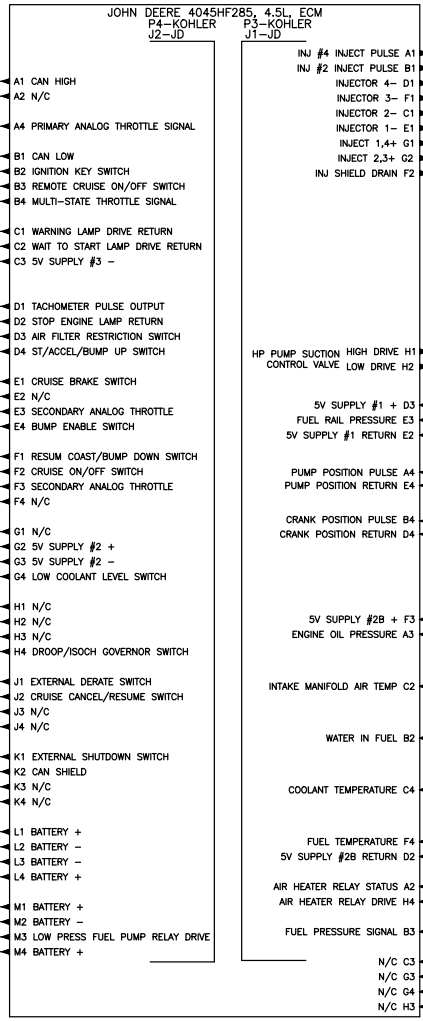
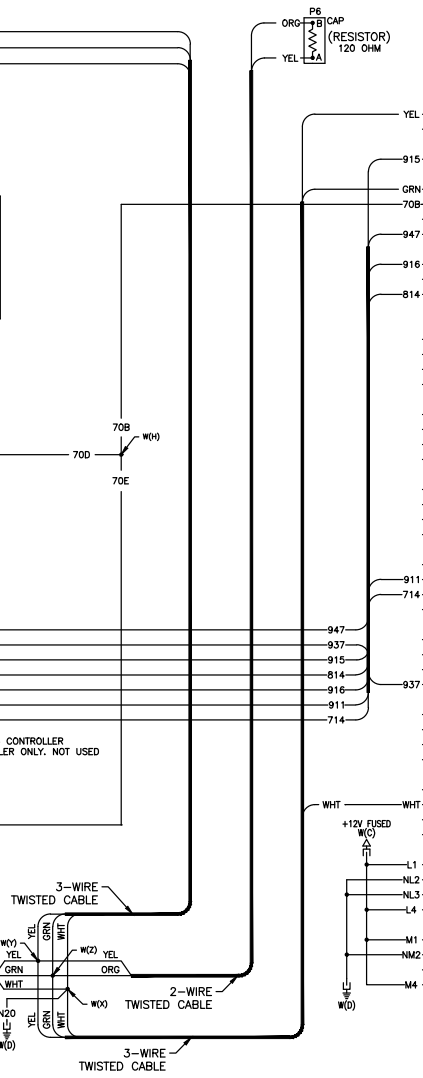
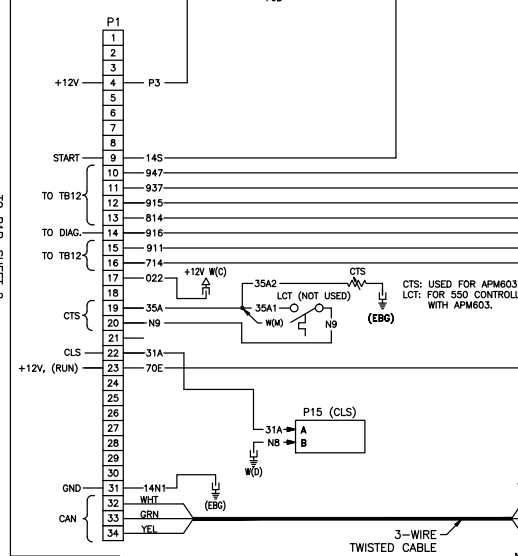
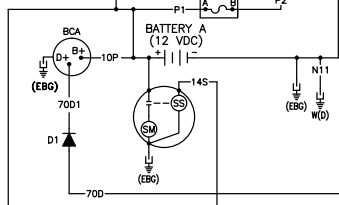
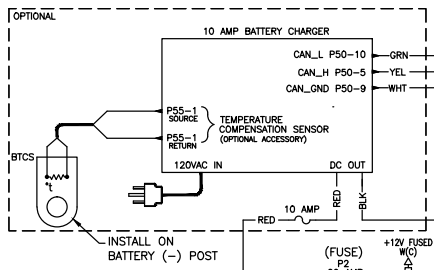

APPROVALS	DATE	REVISION	BY
DESIGNED BY	3-12-18		ASB
CHECKED BY	3-12-18		TLK
APPROVED BY	3-12-18		SMH
DATE	3-12-18		TEV

DIAGRAM, SCHEMATIC
JD 80-300KW, APM603
ADV-9057

APM603 CONTROLLER
80-125 KW JOHN DEERE TIER III
W/ SPLIT ACTIVATOR, 1#, 3# & 600V

ENGINE

REV	DATE	REVISION	BY
-	3-12-18	NEW DRAWING [CT190243]	AKS
A	10-11-18	SEE SHEET 2 [CT191090]	TLK
B	2-05-19	SEE SHEETS 10 & 11 [CT193517]	SMH
C	3-18-19	SEE SHEETS 1 & 2 [CT194009]	SMH
D	5-13-19	SEE SHEETS 1 & 2 [CT194741]	TEV
E	9-10-19	SEE SHEET 2 [CT198500]	TEV

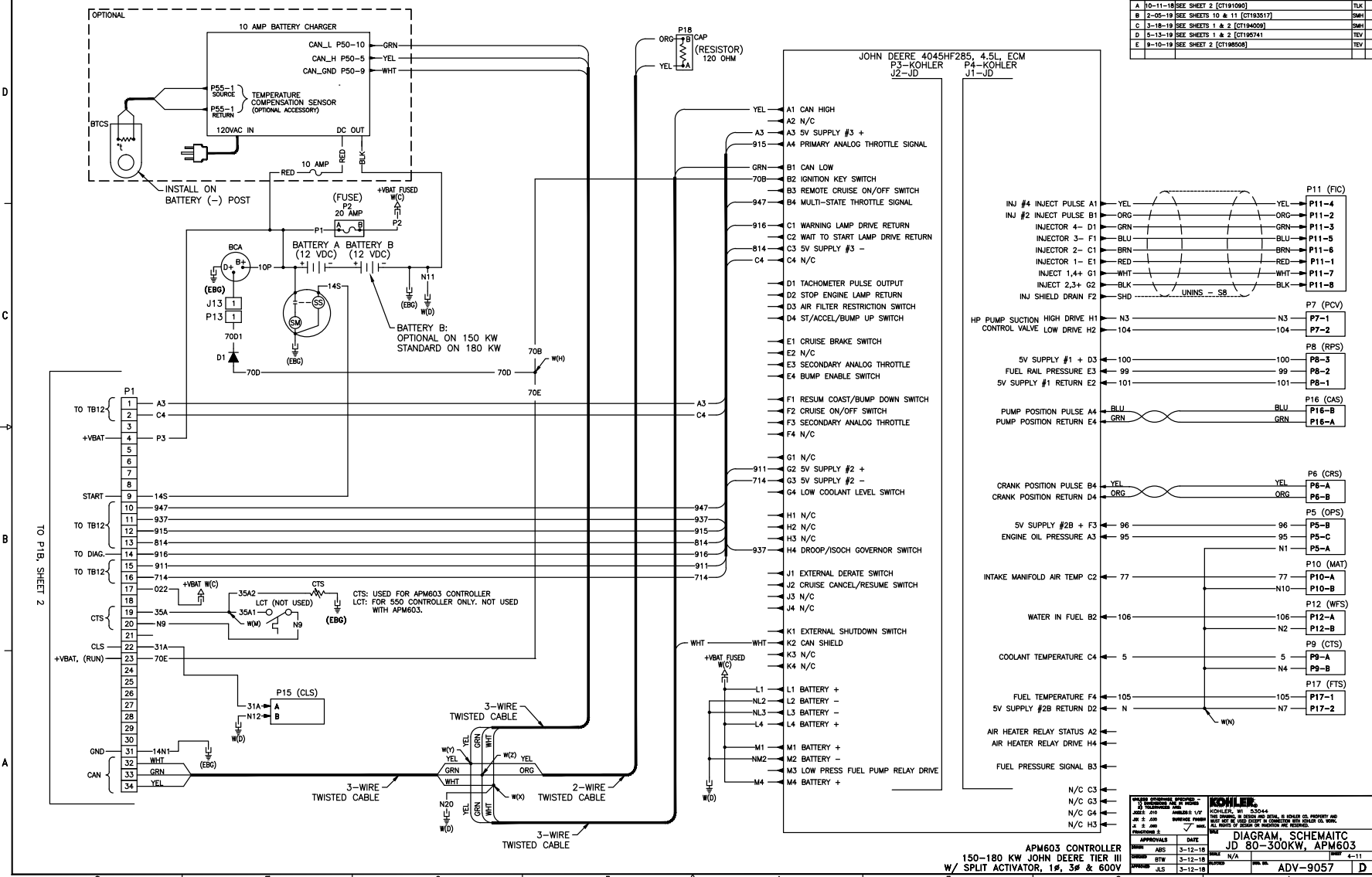

REV	DATE	REVISION	BY
-	3-12-18	NEW DRAWING [CT190243]	AKS
A	10-11-18	SEE SHEET 2 [CT191090]	TLK
B	2-05-19	SEE SHEETS 10 & 11 [CT193517]	SMH
C	3-18-19	SEE SHEETS 1 & 2 [CT194009]	SMH
D	5-13-19	SEE SHEETS 1 & 2 [CT194741]	TEV
E	9-10-19	SEE SHEET 2 [CT198500]	TEV

APM603 CONTROLLER
150-180 KW JOHN DEERE TIER III
W/ SPLIT ACTIVATOR, 1#, 3# & 600V

DIAGRAM, SCHEMATIC
JD 80-300KW, APM603

ADV-9057

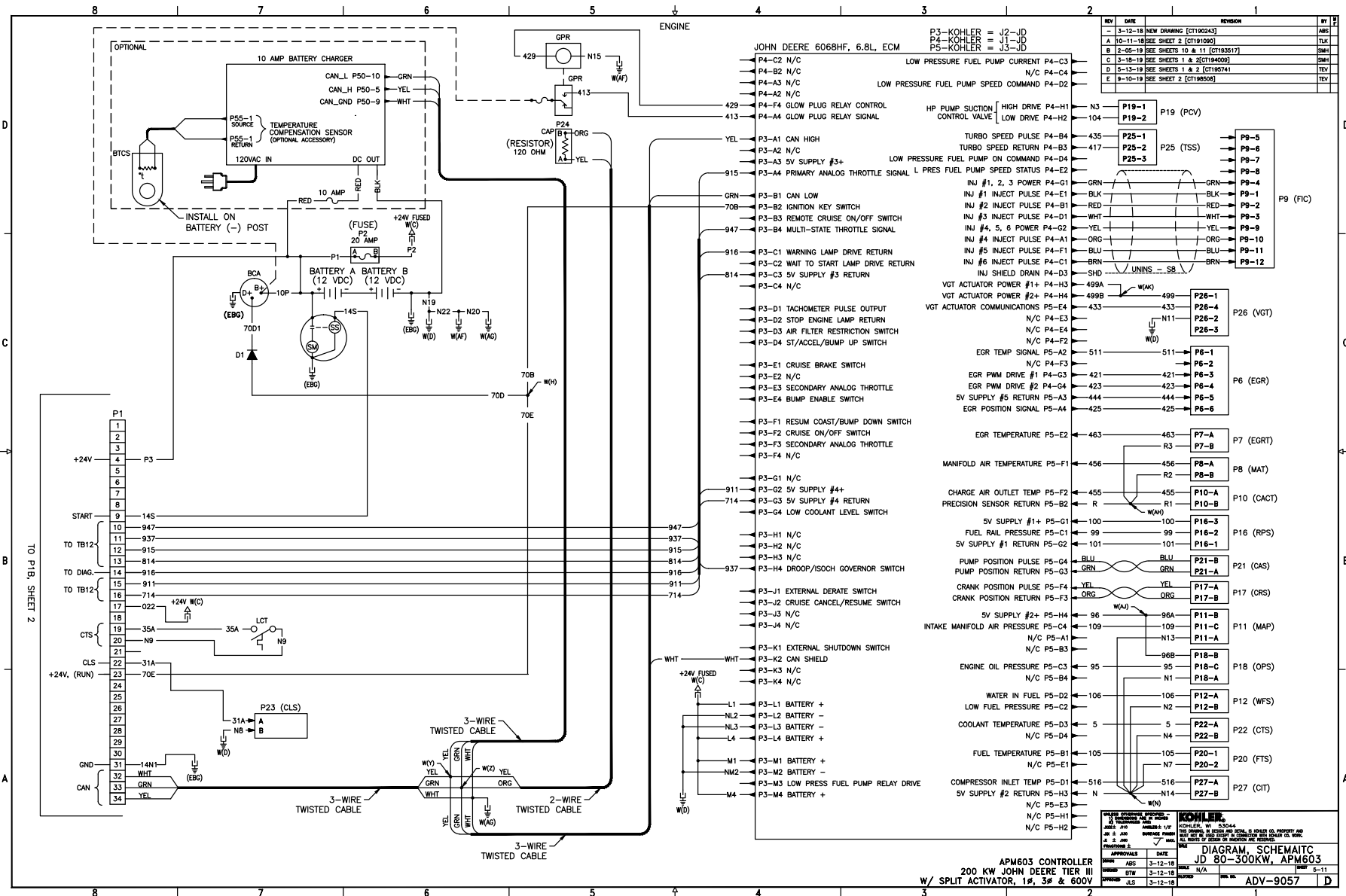

REV	DATE	REVISION	BY
3-12-18		NEW DRAWING [CT190243]	AKS
A	10-11-18	SEE SHEET 2 [CT191090]	TLK
B	2-05-19	SEE SHEETS 10 & 11 [CT193517]	SMH
C	3-18-19	SEE SHEETS 1 & 2 [CT194009]	SMH
D	5-13-19	SEE SHEETS 1 & 2 [CT195974]	TEV
E	9-10-19	SEE SHEET 2 [CT198903]	TEV

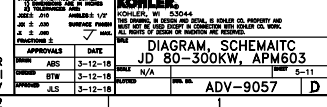
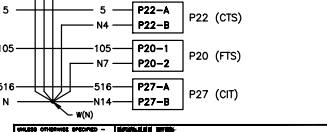
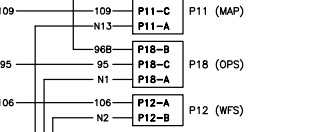
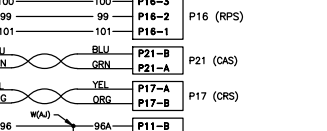
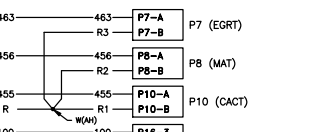
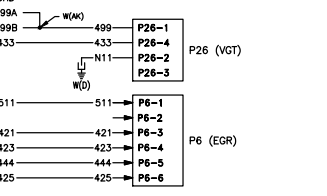
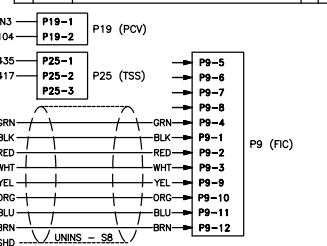

APPROVALS	DATE	DATE	DATE
DESIGNED	3-12-18	DESIGNED	3-12-18
CHECKED	3-12-18	CHECKED	3-12-18
APPROVED	3-12-18	APPROVED	3-12-18

APM603 CONTROLLER
 200 KW JOHN DEERE TIER III
 W/ SPLIT ACTIVATOR, 1#, 3# & 600V

JOHN DEERE
 JOHN DEERE POWERTECH
 JOHN DEERE TRACTORS
 JOHN DEERE CONSTRUCTION EQUIPMENT
 JOHN DEERE AGRICULTURAL EQUIPMENT
 JOHN DEERE INDUSTRIAL EQUIPMENT
 JOHN DEERE MARINE EQUIPMENT
 JOHN DEERE RECREATION EQUIPMENT
 JOHN DEERE SPECIALTY EQUIPMENT
 JOHN DEERE TRACTOR PARTS
 JOHN DEERE TRACTOR SERVICE
 JOHN DEERE TRACTOR TRAINING
 JOHN DEERE TRACTOR SUPPORT
 JOHN DEERE TRACTOR UPGRADES
 JOHN DEERE TRACTOR MAINTENANCE
 JOHN DEERE TRACTOR REPAIRS
 JOHN DEERE TRACTOR PARTS DEPARTMENT
 JOHN DEERE TRACTOR SERVICE DEPARTMENT
 JOHN DEERE TRACTOR TRAINING DEPARTMENT
 JOHN DEERE TRACTOR SUPPORT DEPARTMENT
 JOHN DEERE TRACTOR UPGRADES DEPARTMENT
 JOHN DEERE TRACTOR MAINTENANCE DEPARTMENT
 JOHN DEERE TRACTOR REPAIRS DEPARTMENT

DIAGRAM, SCHEMATIC
 JD 80-300KW, APM603
 ADV-9057

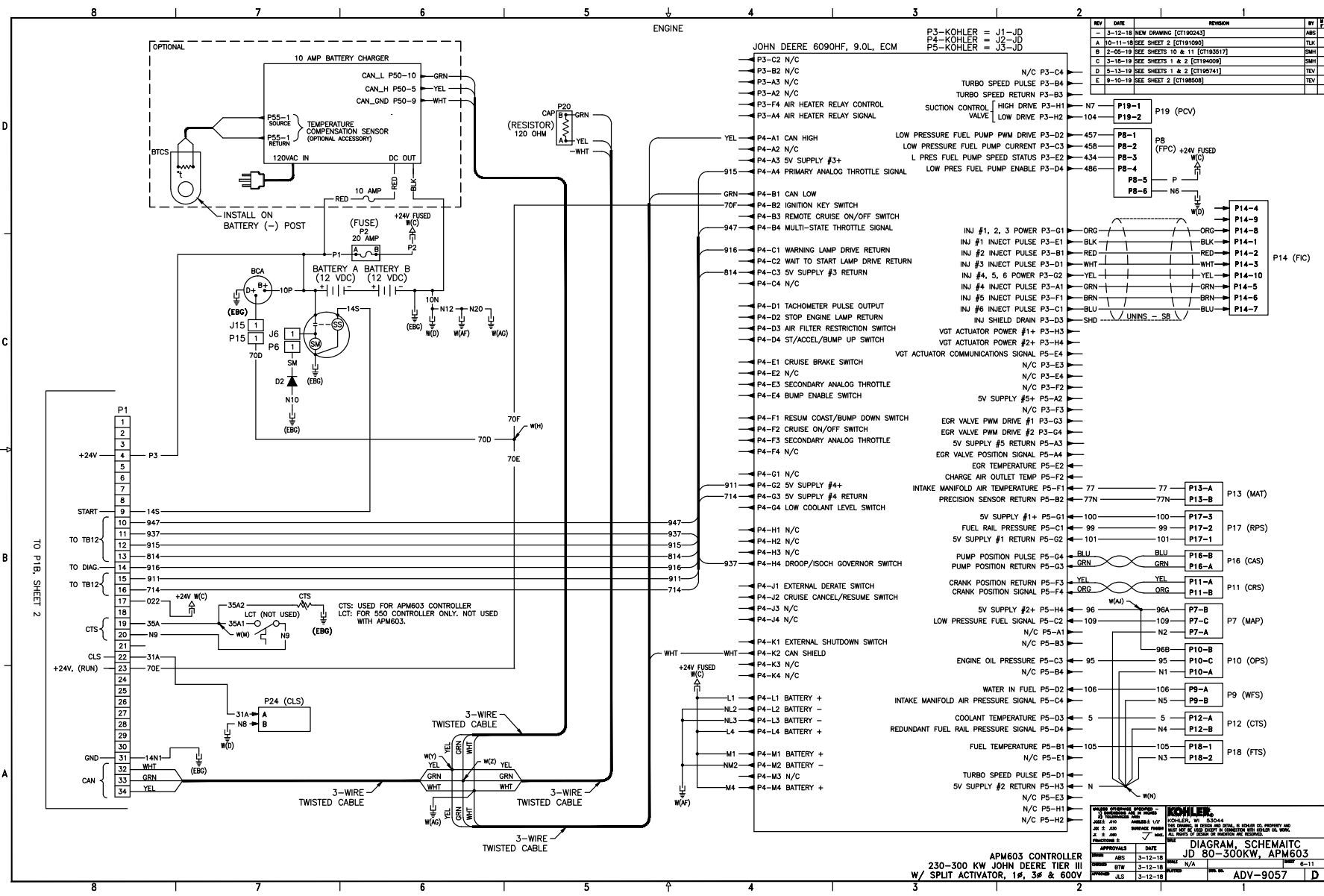

REV	DATE	REVISION	BY
1	3-12-18	NEW DRAWING [CT190243]	AKS
A	10-11-18	SEE SHEET 2 [CT191090]	TLK
B	2-05-19	SEE SHEETS 10 & 11 [CT193517]	SMH
C	3-18-19	SEE SHEETS 1 & 2 [CT194009]	SMH
D	5-13-19	SEE SHEETS 1 & 2 [CT195747]	TEV
E	9-10-19	SEE SHEET 2 [CT198508]	TEV

APPROVALS	DATE	APPROVALS	DATE
DESIGNED BY: [Signature]	3-12-18	CHECKED BY: [Signature]	3-12-18
DRAWN BY: [Signature]	3-12-18	DATE: [Signature]	3-12-18
DATE: [Signature]	3-12-18	DATE: [Signature]	3-12-18

DIAGRAM, SCHEMATIC
JD 80-300KW, APM603
 ADV-9057

ALTERNATOR

REV	DATE	REVISION	BY
-	3-12-18	NEW DRAWING [C7190243]	JAS
A	10-11-18	SEE SHEET 2 [C7191090]	TLK
B	2-05-19	SEE SHEETS 10 & 11 [C7193517]	SMH
C	3-18-19	SEE SHEETS 1 & 2 [C7194009]	SMH
D	5-13-19	SEE SHEETS 1 & 2 [C7193741]	TEV
E	9-10-19	SEE SHEET 2 [C7198500]	TEV

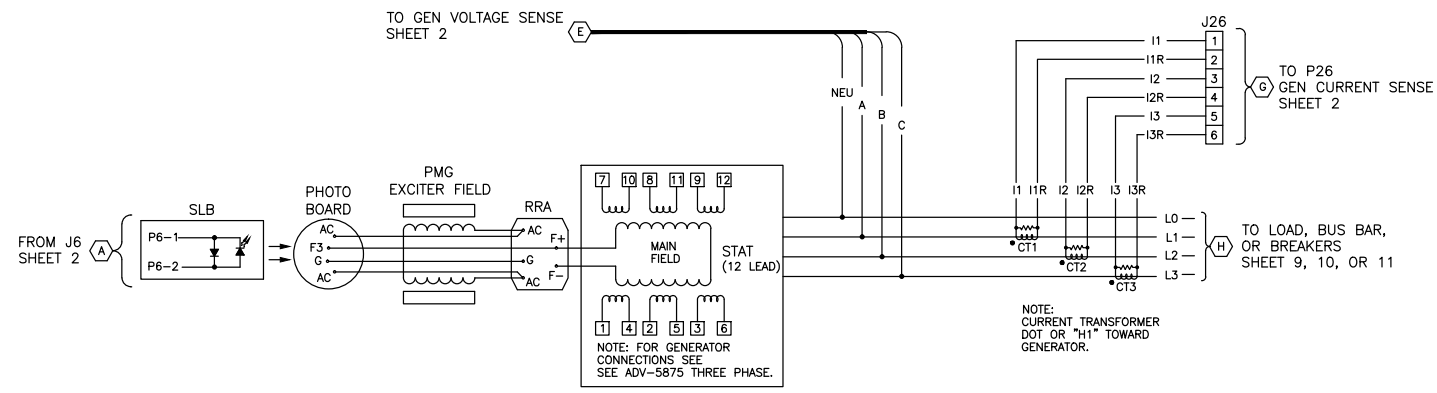

APPROVALS	DATE	BY
JAS	3-12-18	JAS
TLK	10-11-18	TLK
SMH	2-05-19	SMH
SMH	3-18-19	SMH
TEV	5-13-19	TEV
TEV	9-10-19	TEV

KOHLER <small>KOHLER, WI 53044 THE COMPANY IS OFFICE AND STORE IN SEVERAL CITIES THROUGHOUT THE U.S. ALL WORK IS DONE BY THE COMPANY'S OWNERS AND EMPLOYEES.</small>	
ALTERNATOR SIDE APM603 CONTROLLER 80-300 KW JOHN DEERE TIER III W/ SPLIT ACTIVATOR, 1Ø, 3Ø & 600V	DIAGRAM, SCHEMATIC JD 80-300KW, APM603 ADV-9057

ALTERNATOR SIDE
 APM603 CONTROLLER
 80-300 KW JOHN DEERE TIER III
 W/ SPLIT ACTIVATOR, 1Ø, 3Ø & 600V

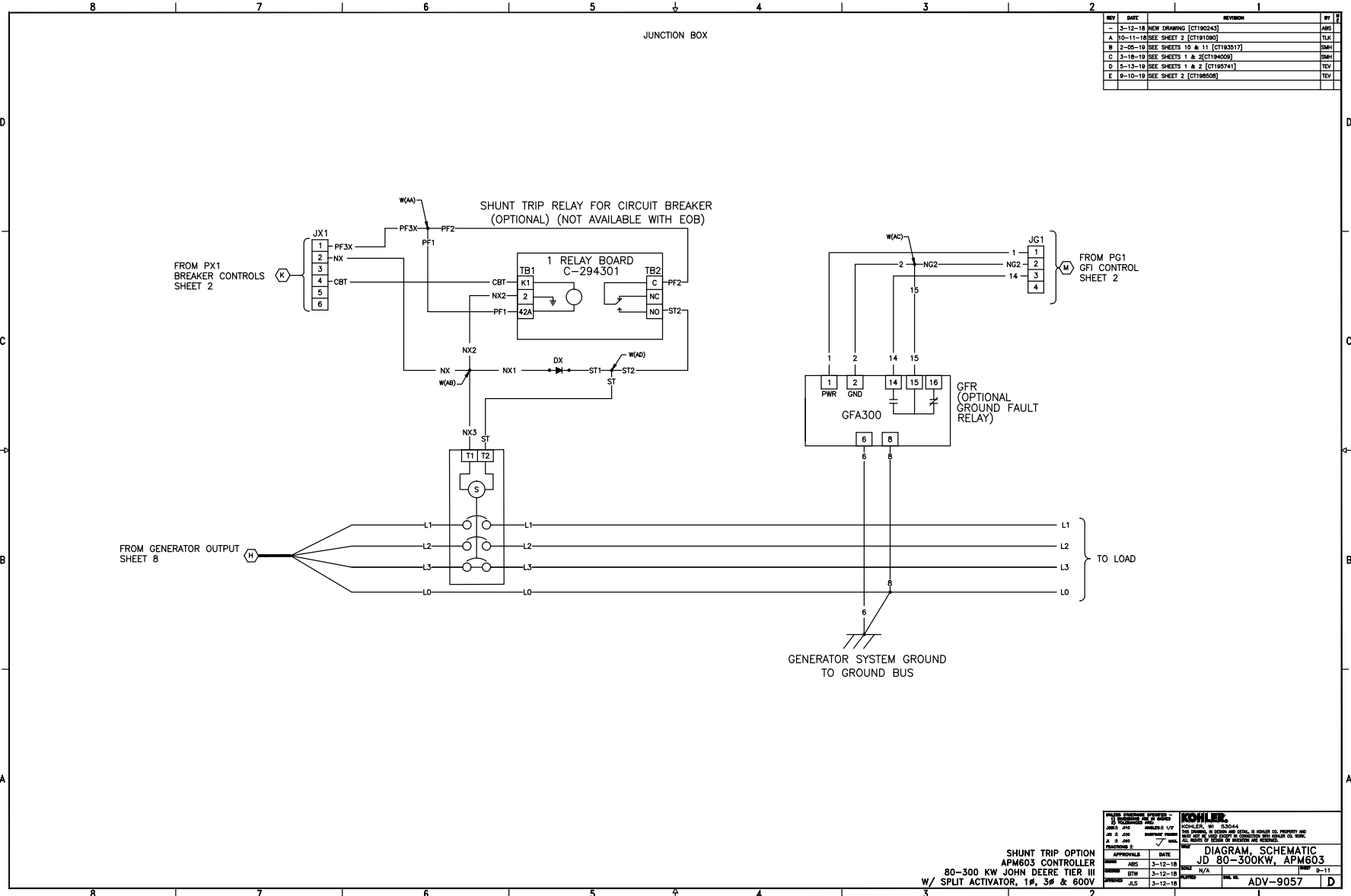

REV	DATE	REVISION	BY
-	3-12-18	NEW DRAWING [C1190243]	ABS
A	10-11-18	SEE SHEET 2 [C1191090]	TLK
B	2-05-19	SEE SHEETS 10 & 11 [C1182517]	SMH
C	3-18-19	SEE SHEETS 1 & 2 [C1194009]	SMH
D	5-13-19	SEE SHEETS 1 & 2 [C1193741]	TEV
E	9-10-19	SEE SHEET 2 [C1198500]	TEV

APPROVALS		DATE		BY	
DESIGNED	ABS	3-12-18	TLK	DATE	3-12-18
CHECKED	BTW	3-12-18	JLS	DATE	3-12-18
APPROVED	JLS	3-12-18		DATE	3-12-18

SHUNT TRIP OPTION
APM603 CONTROLLER
80-300 KW JOHN DEERE TIER III
W/ SPLIT ACTIVATOR, 1#, 3# & 600V

DIAGRAM, SCHEMATIC
JD 80-300KW, APM603

ADV-9057 | D

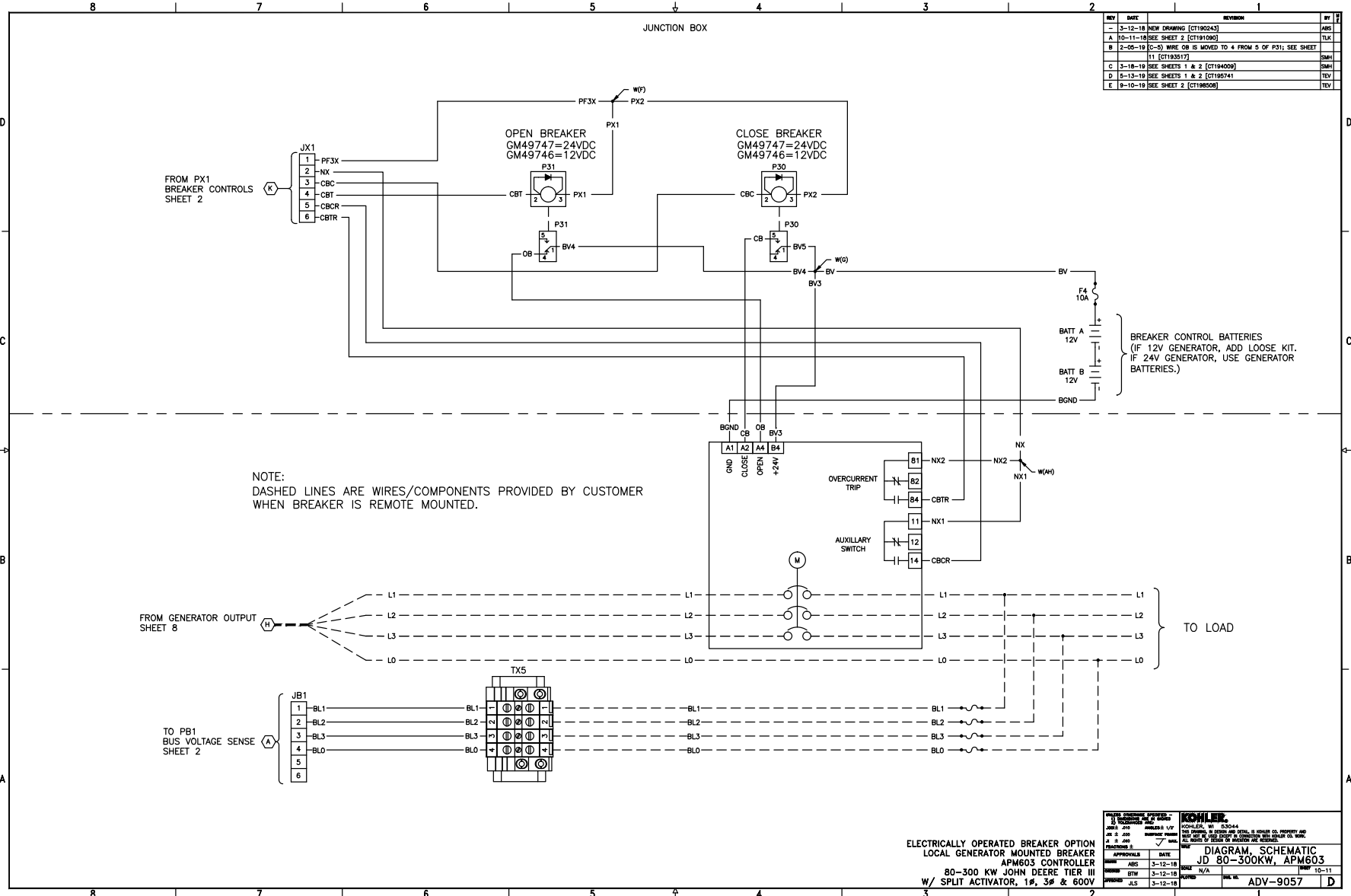

NOTE:
DASHED LINES ARE WIRES/COMPONENTS PROVIDED BY CUSTOMER
WHEN BREAKER IS REMOTE MOUNTED.

REV	DATE	REVISION	BY
1	3-12-18	NEW DRAWING [C1192343]	ABS
A	10-11-18	SEE SHEET 2 [C1191090]	TLK
B	2-05-19	C-5) WIRE OB IS MOVED TO 4 FROM 5 OF P31; SEE SHEET 11 [C1193517]	SMH
C	3-18-19	SEE SHEETS 1 & 2 [C1194000]	SMH
D	2-13-19	SEE SHEETS 1 & 2 [C1195741]	TEV
E	9-10-19	SEE SHEET 2 [C1198508]	TEV

BREAKER CONTROL BATTERIES
(IF 12V GENERATOR, ADD LOOSE KIT.
IF 24V GENERATOR, USE GENERATOR
BATTERIES.)

ELECTRICALLY OPERATED BREAKER OPTION
LOCAL GENERATOR MOUNTED BREAKER
APM603 CONTROLLER
80-300 KW JOHN DEERE TIER III
W/ SPLIT ACTIVATOR, 1#, 3# & 600V

APPROVALS		DATE	
DESIGNED BY	ABS	DATE	3-12-18
CHECKED BY	BTW	DATE	3-12-18
APPROVED BY	JLS	DATE	3-12-18

KOHLER	
KOHLER, WI 53044	
180 WINDYBUSH DRIVE, WISCONSIN, U.S.A.	
ALL RIGHTS RESERVED. NO PART OF THIS PUBLICATION MAY BE REPRODUCED OR TRANSMITTED IN ANY FORM OR BY ANY MEANS, ELECTRONIC OR MECHANICAL, INCLUDING PHOTOCOPYING, RECORDING, OR BY ANY INFORMATION STORAGE AND RETRIEVAL SYSTEM.	
PROJECT NO.	ADV-9057
DRAWING NO.	JD 80-300KW, APM603
SCALE	10-11

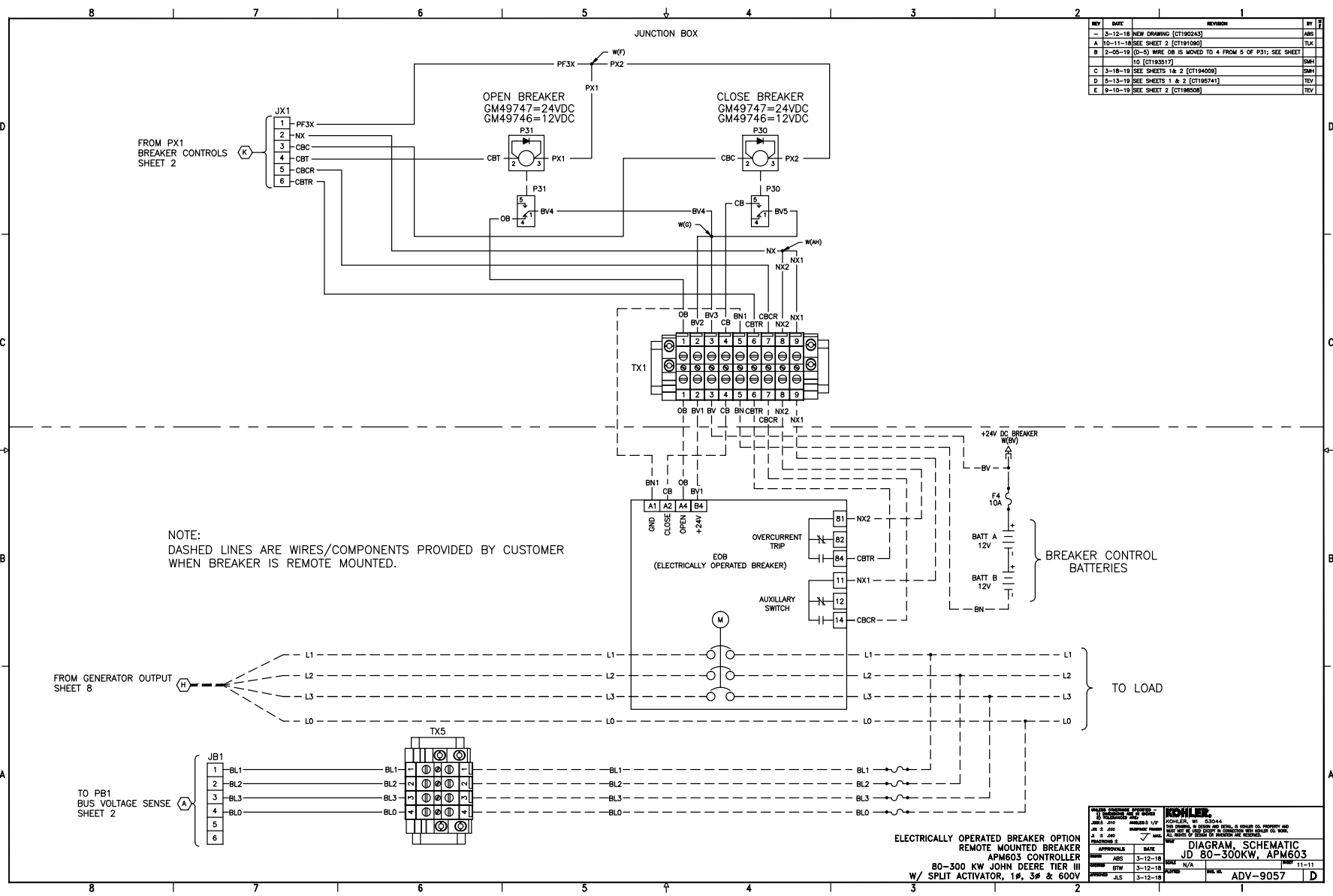

REV	DATE	REVISION	BY
-	3-12-18	NEW DRAWING [CT190243]	ABS
A	10-11-18	SEE SHEET 2 [CT191090]	TLX
B	2-05-19	(D-S) WIRE OB IS MOVED TO 4 FROM 5 OF P31; SEE SHEET 10 [CT193517]	SMI
C	3-18-19	SEE SHEETS 1 & 2 [CT194009]	SMI
D	2-13-19	SEE SHEETS 1 & 2 [CT190741]	TEV
E	9-10-19	SEE SHEET 2 [CT190508]	TEV

APPROVALS	DATE	BY
DESIGNED BY		
CHECKED BY		
APPROVED BY		
DATE		

KOHLER
KOHLENER, WI 53044
1800 W. STATE ST. DEPT. 8000
ALL RIGHTS RESERVED. NO PARTS TO BE REPRODUCED OR TRANSMITTED IN ANY FORM OR BY ANY MEANS, ELECTRONIC OR MECHANICAL, INCLUDING PHOTOCOPYING, RECORDING, OR BY ANY INFORMATION STORAGE AND RETRIEVAL SYSTEM.

**DIAGRAM, SCHEMATIC
JD 80-300KW, APM603**

ADV-9057

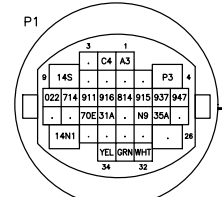

P1 CONNECTIONS

PIN #1	A3 (P3-A3)	18	N/C
2	C4 (P3-C4)	19	35A (W(M))
3	N/C	20	N9 (LCT)
4	P3 (SS)	21	N/C
5	N/C	22	31A (P15-A)
6	N/C	23	70E (W(H))
7	N/C	24	N/C
8	N/C	25	N/C
9	14S (SS)	26	N/C
10	947 (P3-B4)	27	N/C
11	937 (P3-H4)	28	N/C
12	915 (P3-A4)	29	N/C
13	814 (P3-C3)	30	N/C
14	916 (P3-C1)	31	14N1 (EBG)
15	911 (P3-G2)	32	WHT (W(X))
16	714 (P3-G3)	33	GRN (W(Z))
17	022 (W(C))	34	YEL (W(Y))

P5 CONNECTIONS

PIN A	N1 (W(N))
B	96 (P4-F3)
C	95 (P4-A3)

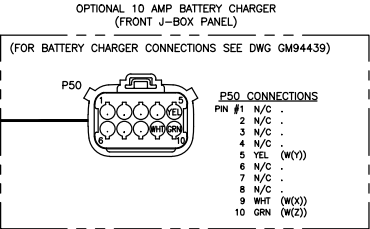
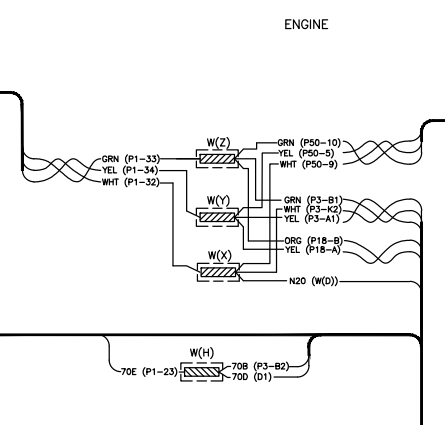

P50 CONNECTIONS

PIN #1	N/C
2	N/C
3	N/C
4	N/C
5	YEL (W(Y))
6	N/C
7	N/C
8	N/C
9	WHT (W(X))
10	GRN (W(Z))

P9 CONNECTIONS

PIN A	5 (P4-C4)
B	N4 (W(N))



P16 CONNECTIONS

PIN A	GRN (P4-E4)
B	BLU (P4-A4)

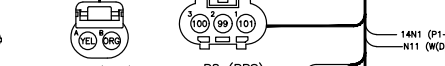

P12 CONNECTIONS

PIN A	106 (P4-E2)
B	N2 (W(N))



P18 CONNECTIONS

PIN A	YEL (W(Y))
B	ORG (W(Z))

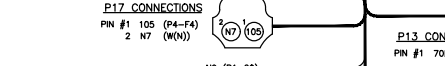

P17 CONNECTIONS

PIN #1	105 (P4-F4)
2	N7 (W(N))

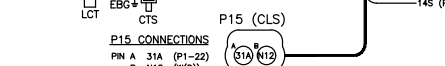

P15 CONNECTIONS

PIN A	31A (P1-22)
B	N12 (W(D))

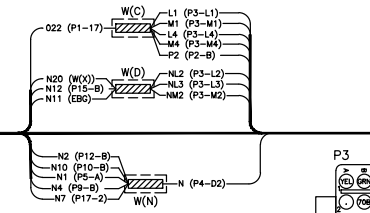

REV	DATE	REVISION	BY
C	3-18-19	SEE SHEETS 1 & 8 [C1194030]	SMI
D	5-13-19	SEE SHEETS 1 & 2 [C1195741]	TEV
E	4-3-20	SEE SHEET 1 [C720707]	DFP
F	9-29-20	SEE SHEET 1 [C720707]	TEV
G	7-26-21	SEE SHEET 7 [C213571]	TEV

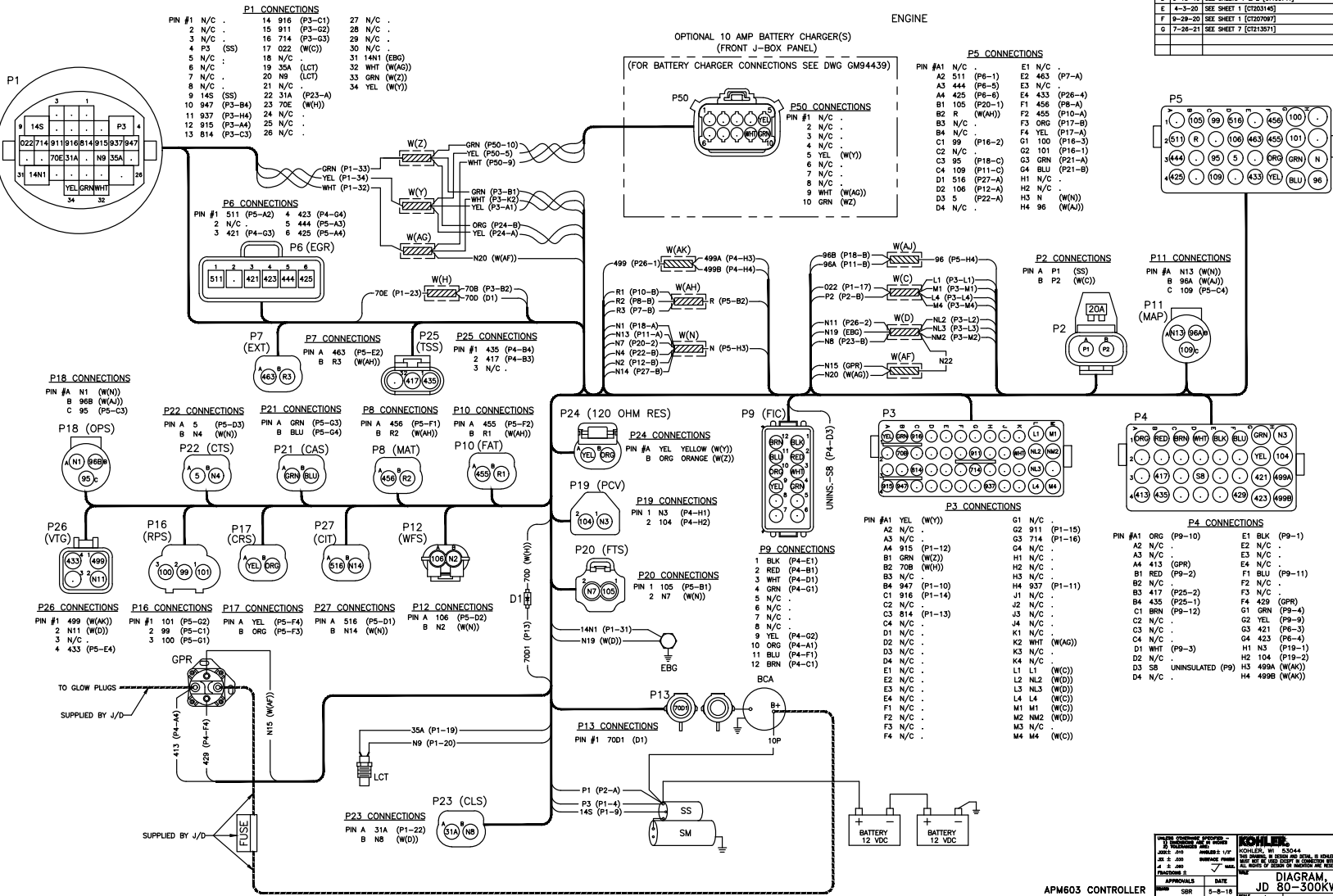

APM603 CONTROLLER
200 KW JOHN DEERE TIER III
W/ SPLIT ACTIVATOR, 1#, 3# & 600V

DIAGRAM, WIRING
JD 80-300KW, APM603

DATE: 5-9-18
BY: TJK
CHECKED: 8-14-18
APPROVED: 8-14-18

GM105223

REV	DATE	REVISION	BY
C	3-18-19	SEE SHEETS 1 & 8 [C1194000]	SMI
D	5-13-19	SEE SHEETS 1 & 2 [C1195741]	TEV
E	4-3-20	SEE SHEET 1 [C1203145]	DFS
F	9-29-20	SEE SHEET 1 [C1207097]	TEV
G	7-26-21	SEE SHEET 7 [C1213571]	TEV

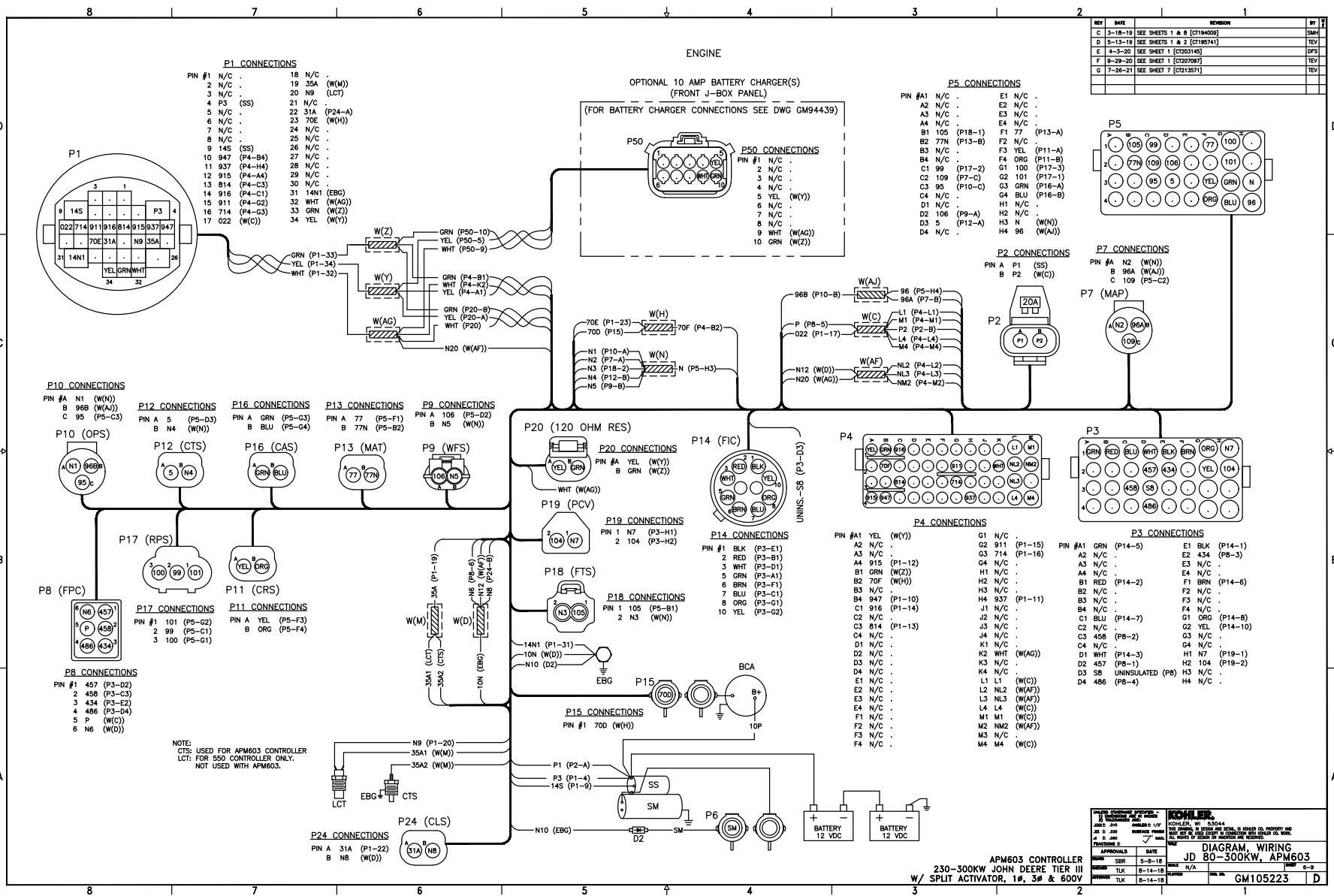

JOHN DEERE JOHN DEERE TRACTOR & EQUIPMENT DIV. JOHN DEERE TRACTOR & EQUIPMENT DIV. JOHN DEERE TRACTOR & EQUIPMENT DIV. JOHN DEERE TRACTOR & EQUIPMENT DIV.	KOHLER KOHLER, INC. KOHLER, INC. KOHLER, INC. KOHLER, INC.
APPROVALS DATE: 5-8-18 DATE: 8-14-18 DATE: 8-14-18	DIAGRAM WIRING JD 80-300KW, APM603 N/A GM105223

APM603 CONTROLLER
230-300KW JOHN DEERE TIER III
W/ SPLIT ACTIVATOR, 1#, 3# & 600V

REV	DATE	REVISION	BY
C	3-18-19	SEE SHEETS 1 & 2 [C119400]	SMH
D	5-13-20	SEE SHEETS 1 & 2 [C1195741]	TEV
E	4-3-20	SEE SHEET 1 [C1203145]	DFS
F	9-29-20	SEE SHEET 1 [C1207097]	TEV
G	7-26-21	(B-1,2) TERMINATING RESISTOR KITS ADDED [C1213571]	TEV

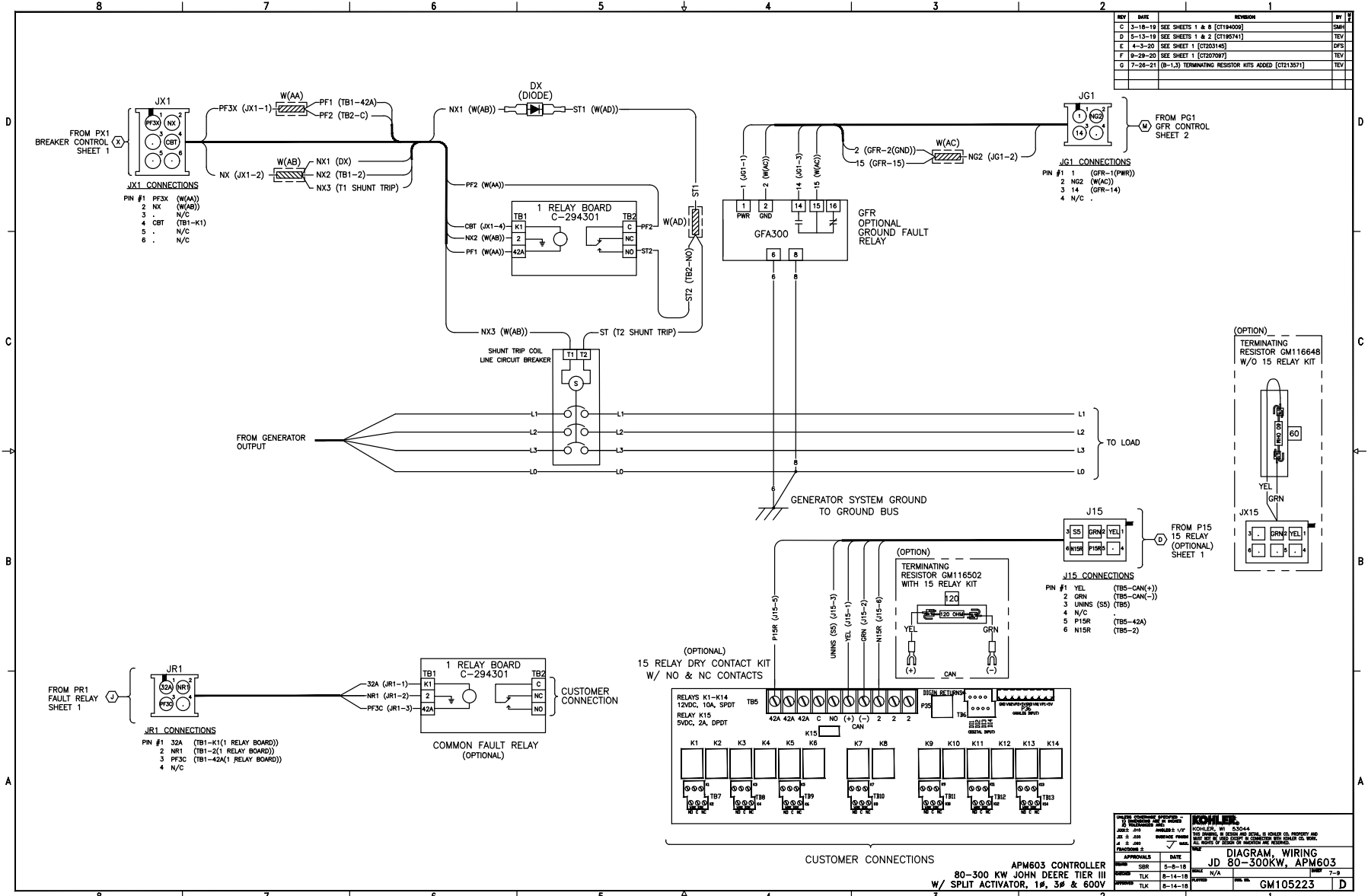

APPROVED BY	DATE	APPROVED BY	DATE
SMH	3-18-19	SMH	3-18-19
TEV	5-13-20	TEV	5-13-20
DFS	4-3-20	DFS	4-3-20
TEV	9-29-20	TEV	9-29-20
TEV	7-26-21	TEV	7-26-21

APM603 CONTROLLER
80-300 KW JOHN DEERE TIER III
W/ SPLIT ACTIVATOR, 1#, 3# & 600V

DIAGRAM, WIRING
JD 80-300KW, APM603

GM105223

REV	DATE	REVISION	BY
C	3-18-19	(D-5) F4 ADDED SEE SHEET 1 [C1184009]	SMC
D	5-13-19	SEE SHEETS 1 & 2 [C1185741]	TEV
E	4-3-20	SEE SHEET 1 [C1203145]	WFS
F	9-29-20	SEE SHEET 1 [C1207097]	TEV
G	7-26-21	SEE SHEET 7 [C1215071]	TEV

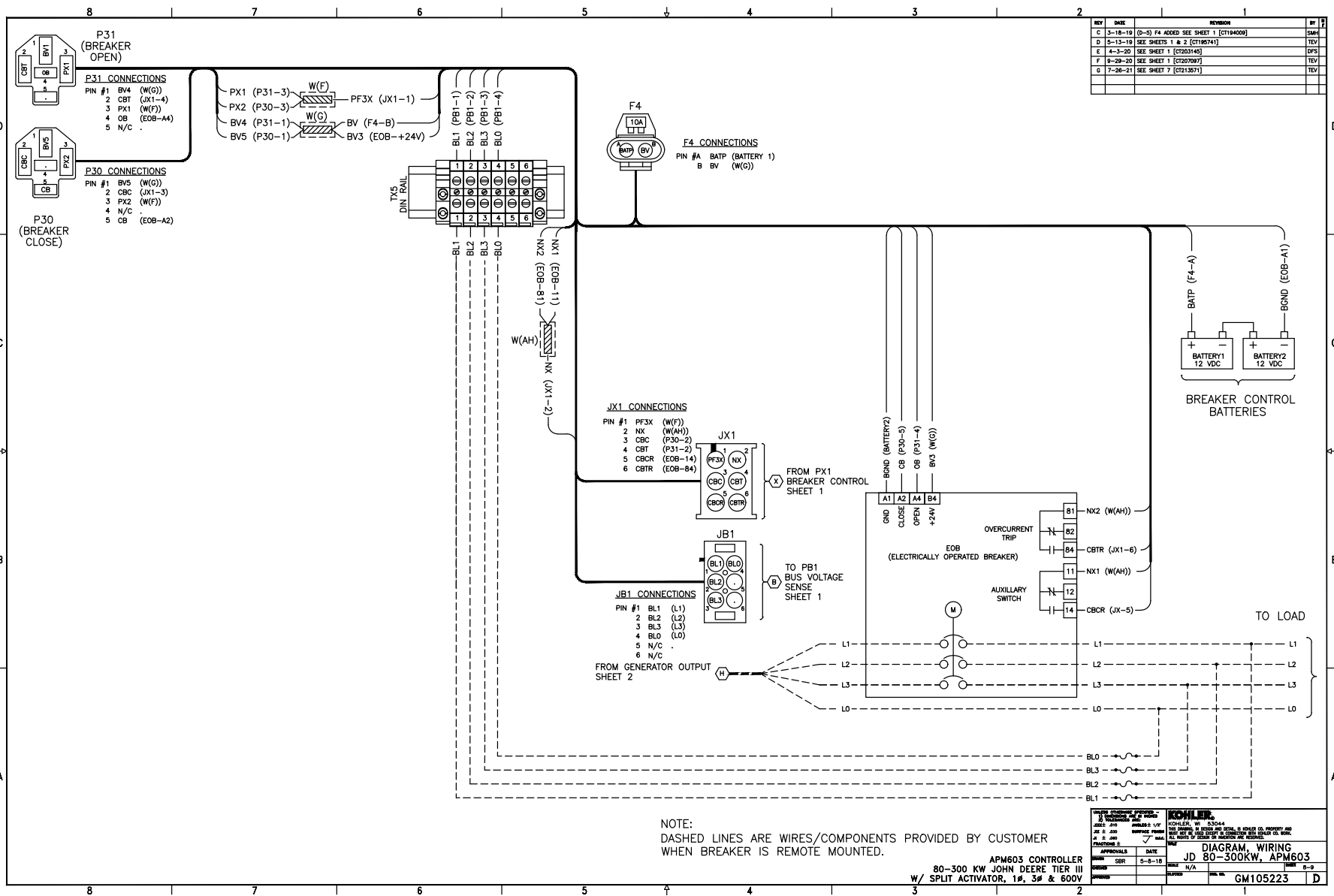

APM603 CONTROLLER
80-300 KW JOHN DEERE TIER III
W/ SPLIT ACTIVATOR, 1#, 3# & 600V

KOHLER
KOHLEN, WI 53044
DATE: 5-8-18
REV: N/A
PART NO: GM105223

DIAGRAM WIRING
JD 80-300KW, APM603

APPROVALS: [Signature] DATE: [Date]

REV	DATE	REVISION	BY
C	3-18-19	SEE SHEETS 1 & 2 [C1194003]	SMK
D	5-13-19	SEE SHEETS 1 & 2 [C1195741]	TEV
E	4-3-20	SEE SHEET 1 [C1203145]	DFS
F	9-29-20	SEE SHEET 1 [C1207097]	TEV
G	7-26-21	SEE SHEET 7 [C1213571]	TEV

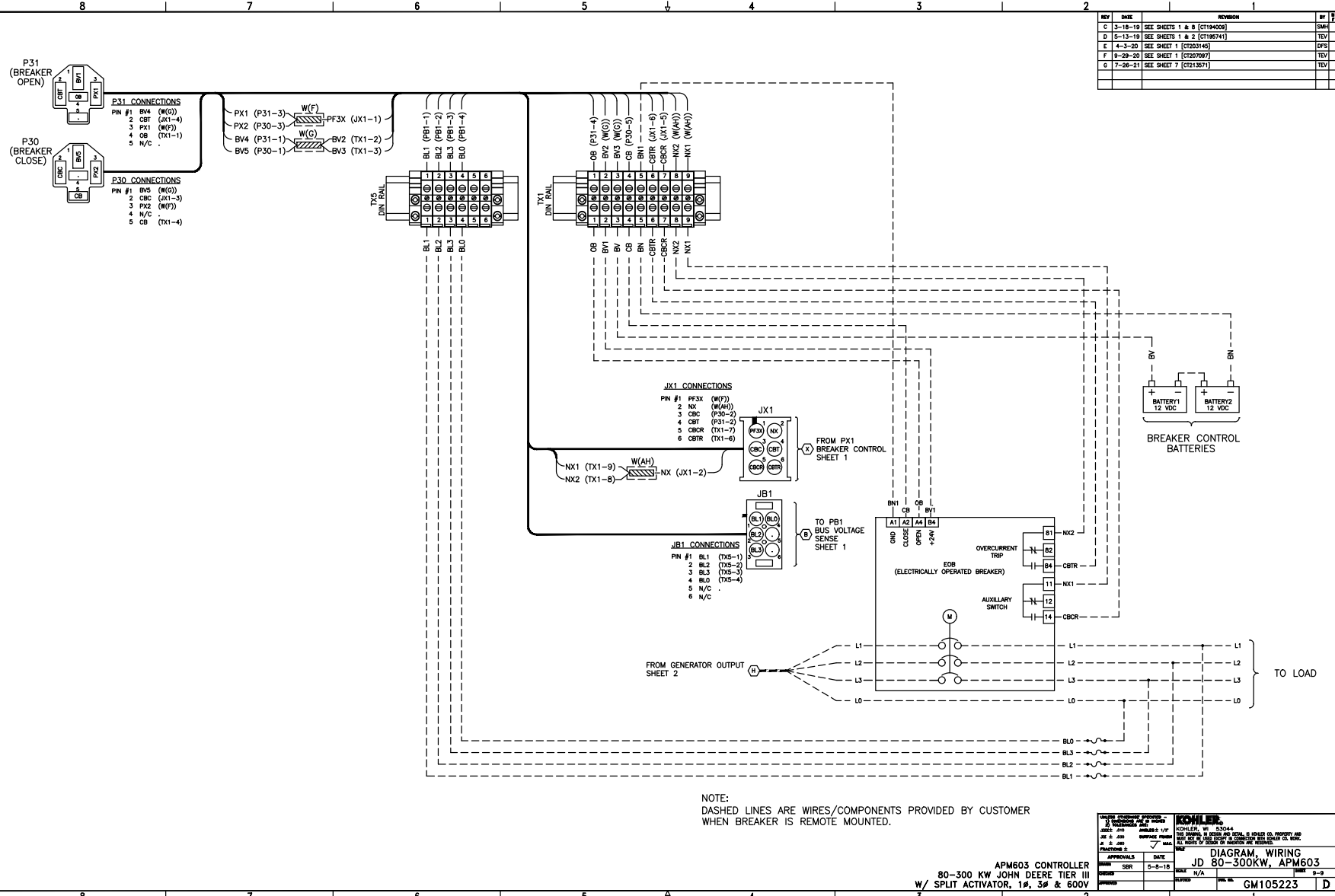

APM603 CONTROLLER 80-300 KW JOHN DEERE TIER III W/ SPLIT ACTIVATOR, 1#, 3# & 600V	APM603 CONTROLLER 80-300 KW JOHN DEERE TIER III W/ SPLIT ACTIVATOR, 1#, 3# & 600V	APM603 CONTROLLER 80-300 KW JOHN DEERE TIER III W/ SPLIT ACTIVATOR, 1#, 3# & 600V	APM603 CONTROLLER 80-300 KW JOHN DEERE TIER III W/ SPLIT ACTIVATOR, 1#, 3# & 600V
--	--	--	--

KOHLER®

Miscellaneous

8 7 6 5 4 3 2 1

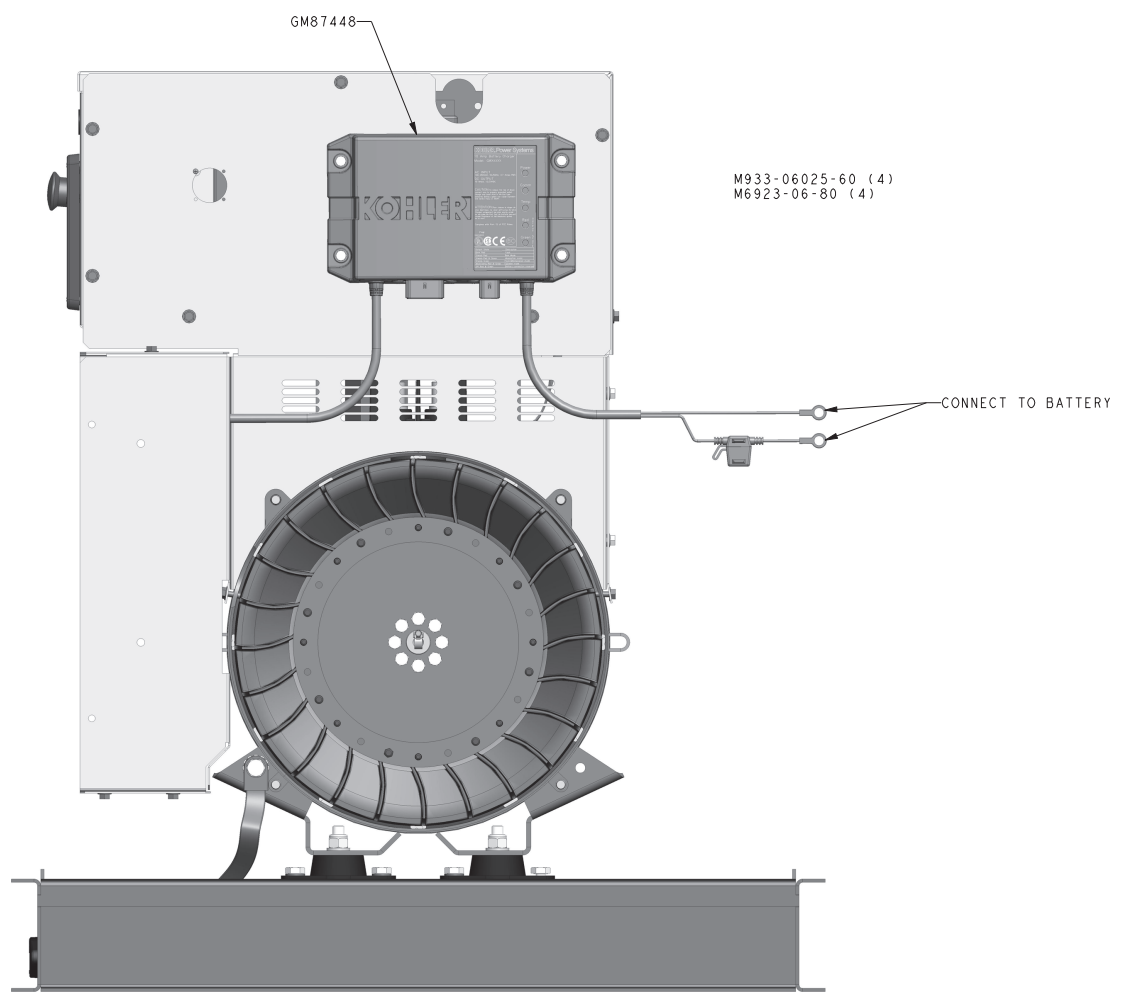

VIEW 3

REV	DATE	ON COMPOSITE DWGS. SEE PART NO. FOR REVISION LEVEL	BY	UNLESS OTHERWISE SPECIFIED:	KOHLER CO. METRIC PRO-E POWER SYSTEMS, KOHLER, WI 53044 U.S.A. THIS DRAWING IN DESIGN AND DETAIL IS KOHLER CO. PROPERTY AND MUST NOT BE USED EXCEPT IN CONNECTION WITH KOHLER CO. WORK. ALL RIGHTS OF DESIGN OR INVENTION ARE RESERVED.
A	2-16-18	VIEW 3 ADDED [CT184382]	KRM	1) DIMENSIONS ARE IN MILLIMETERS 2) TOLERANCES ARE: 3-XX ± 0.25 2-XX ± 0.15 1-XX ± 0.10	
B	04MAY2022	SEE SHEET 1 [CT219524]	PBC	3) SURFACE FINISH 4) ANGLES ± 0° 30' MAX.	
				THIRD ANGLE PROJECTION 	
				APPROVALS DATE DRAWN SAM 2-16-18 CHECKED SAM 2-16-18 APPROVED AGT 2-16-18	
				TITLE DWG, ASSY BATTERY CHARGER	
				SCALE 0.25 CAD NO. SHEET 2 of 2 DWG NO. GM94447	

8 7 6 5 4 3 2 1

KOHLER®

Warranty

Stationary Standby and Prime Power Industrial Generator Set One-Year or Two Thousand (2000)-Hour Limited Warranty

Your Kohler product has been manufactured and inspected with care by experienced craftsmen. If you are the original end user, Kohler Co. warrants, for the period indicated below, each product to be free from defects in materials and workmanship. In the event of a defect in materials or workmanship, Kohler Co. will repair, replace, or make appropriate adjustment at Kohler Co.'s option if the product, upon Kohler Co.'s inspection, is found to be properly installed, maintained, and operated in accordance with Kohler Co.'s instruction manuals. A Kohler distributor, dealer, or authorized service representative must perform startup.

Kohler Product

Stationary Standby Generator Set & Accessories

Warranty Coverage

One (1) year from registered startup or two thousand (2000) hours (whichever occurs first). In any event, the warranty period will expire not later than thirty (30) months from the date of shipment from Kohler Co.'s factory.

Stationary Prime Power Generator Set & Accessories

One (1) year from registered startup or two thousand (2000) hours (whichever occurs first). In any event, the warranty period will expire not later than thirty (30) months from the date of shipment from Kohler Co.'s factory.

The following will **not** be covered by the warranty:

1. Normal wear, routine tuneups, tuneup parts, adjustments, and periodic service.
2. Damage, including but not limited to damage caused by accidents, improper installation or handling, faulty repairs not performed by an authorized Kohler service representative, improper storage, or acts of God.
3. Damage caused by operation at speeds, or with fuel, loads, conditions, modifications or installation contrary to published specifications.
4. Damage caused by negligent maintenance such as:
 - a. Failure to provide the specified type and sufficient quantity of lubricating oil.
 - b. Failure to keep the air intake and cooling fin areas clean.
 - c. Failure to service the air cleaner.
 - d. Failure to provide sufficient coolant and/or cooling air.
 - e. Failure to perform scheduled maintenance as prescribed in supplied manuals.
 - f. Failure to regularly exercise the generator set under load (stationary applications only).
5. Original installation charges and startup costs.
6. Starting batteries and the following related expenses:
 - a. Labor charges related to battery service.
 - b. Travel expenses related to battery service.
7. Additional expenses for repairs performed after normal business hours, i.e. overtime or holiday labor rates.
8. Rental of equipment during the performance of warranty repairs.
9. Removal and replacement of non-Kohler-supplied options and equipment.
10. Non-Kohler replacement parts. Replacement of a failed Kohler part with a non-Kohler part voids the warranty on that part.
11. Radiators replaced rather than repaired.
12. Fuel injection pumps not repaired by an authorized Kohler service representative.
13. Non-Kohler-authorized repair shop labor without prior approval from Kohler Co. Warranty Department.
14. Engine fluids such as fuel, oil, or coolant/antifreeze.
15. Shop supplies such as adhesives, cleaning solvents, and rags.
16. Expenses incurred investigating performance complaints unless the problem is caused by defective Kohler materials or workmanship.
17. Maintenance items such as fuses, lamps, filters, spark plugs, loose or leaking clamps, and adjustments.
18. Travel time and mileage exceeding 300 miles round trip.

To obtain warranty service, call 1-800-544-2444 for your nearest authorized Kohler service representative or write Kohler Co., Service Department, MS072, Kohler, WI 53044 USA.

KOHLER CO. SHALL NOT BE LIABLE FOR SPECIAL, INCIDENTAL, AND/OR CONSEQUENTIAL DAMAGES OF ANY KIND including, but not limited to, incidental and/or consequential labor costs, installation charges, telephone charges, or transportation charges in connection with the replacement or repair of defective parts.

This is our exclusive written warranty. We make no other express warranty nor is anyone authorized to make any on our behalf.

ANY IMPLIED OR STATUTORY WARRANTY, INCLUDING ANY WARRANTY OF MERCHANTABILITY OR FITNESS FOR A PARTICULAR PURPOSE, IS EXPRESSLY LIMITED TO THE DURATION OF THIS WARRANTY. Some states do not allow limitations on how long an implied warranty lasts, or the exclusion or limitation of incidental and/or consequential damages, so the above limitation or exclusion may not apply to you.

This warranty gives you specific legal rights, and you may also have other rights which vary from state to state.

KOHLER®

KOHLER CO., Kohler, Wisconsin 53044
Phone 920-457-4441, Fax 920-459-1646
For the nearest sales/service outlet in the US and Canada, phone 1-800-544-2444
KOHLERPower.com

TP-5374 12/15f

KOHLER®

Certification

Certificate of Registration

QUALITY MANAGEMENT SYSTEM - ISO 9001:2015

This is to certify that:

Kohler Power Systems
N7650 Lakeshore Road
Sheboygan
Wisconsin
53083
USA

Holds Certificate No:

FM 727336

and operates a Quality Management System which complies with the requirements of ISO 9001:2015 for the following scope:

Design, manufacture, and distributor support for electrical generators, alternators, fuel tanks, automatic transfer switches and switchgear.

For and on behalf of BSI:



Carlos Pitanga, Chief Operating Officer Assurance – Americas

Original Registration Date: 1995-02-28

Latest Revision Date: 2021-10-29

Effective Date: 2021-11-07

Expiry Date: 2024-11-06

Page: 1 of 2



...making excellence a habit.™

Certificate No: **FM 727336**

Location	Registered Activities
Kohler Power Systems - GK 900 Highland Drive Bldg 604 Kohler Wisconsin 53004 USA	Manufacture of leads and harness, automatic transfer switches and switchgear. Distribution of generator sets.
Kohler Power Systems N7650 Lakeshore Road Sheboygan Wisconsin 53083 USA	Design, manufacture, and distributor support for electrical generators, automatic transfer switches and switchgear.
Kohler Power Systems 300 N Dekora Woods Blvd Saukville Wisconsin 53080 USA	Manufacture of fuel tanks, skids, fabricated components and generators.
Kohler Power Systems Muth Warehouse 2821 Muth Court Sheboygan Wisconsin 53083 USA	The distribution of generator sets.
Kohler Power Systems KWIP Warehouse 4327 County EE Sheboygan Wisconsin 53081 USA	Receiving, sequencing and warehousing of generator components.

Original Registration Date: 1995-02-28

Latest Revision Date: 2021-10-29

Effective Date: 2021-11-07

Expiry Date: 2024-11-06

Page: 2 of 2

This certificate remains the property of BSI and shall be returned immediately upon request.

An electronic certificate can be authenticated [online](http://www.bsigroup.com/ClientDirectory). Printed copies can be validated at www.bsigroup.com/ClientDirectory
To be read in conjunction with the scope above or the attached appendix.

Information and Contact: BSI, Kitemark Court, Davy Avenue, Knowlhill, Milton Keynes MK5 8PR. Tel: + 44 345 080 9000
BSI Assurance UK Limited, registered in England under number 7805321 at 389 Chiswick High Road, London W4 4AL, UK.
A Member of the BSI Group of Companies.

G15-152 10/21

PROTOTYPE TEST REPORT



Models Covered: **100REOZJF**
Model Tested: **100REOZJE**
Cooling System Tested: **50C**

Alternator Tested: **4S9**
Engine Tested: **4045HF285L**
Voltage Tested: **208V**

GENSET

Maximum power test to assure that the prime mover and alternator have sufficient capacity to operate within specifications.

Meets Rated Load

Steady-state load test to ensure voltage stability meets or exceeds ISO8528-5 requirements and to verify compliance with steady state speed control specifications.

± 0.25 % Frequency Band

± 0.50 % Voltage Deviation

Transient load tests per NEMA MG1-32.18, and ISO 8528 to verify specifications of transient voltage regulation, voltage dip, voltage overshoot, recovery voltage, and recovery time. Values shown for model tested above. Please contact factory for additional details.

Full Load Acceptance

32.1 % Voltage Dip

3.90 Seconds of Recovery Time

22.5 % Frequency Dip

3.70 Seconds of Recovery Time

Full Load Rejection

19.1 % Voltage Overshoot

1.50 Seconds of Recovery Time

5.90 % Frequency Overshoot

0.40 Seconds of Recovery Time

G3 ISO8528-5 Class (G1, G2, G3)

NFPA 110 one step testing to determine the amount of time required for the generator set to reach 90% voltage and frequency to allow the ATS to transfer.

Complies with NFPA 110 Type 10

Vibrational analysis to verify that generator vibrations are within acceptable limits per ISO 8528-9.

Complies

Torsional analysis data to verify torsional effects are not detrimental and that the generator set will provide dependable service as specified.

Complies

Generator set cooling and air flow tests to verify maximum operating ambient temperature. (Cooling system test results are available on TIB-118)

Acoustical noise intensity and sound attenuation effects tests (Acoustical noise results are available on TIB-114 &115)

Exhaust Back Pressure test completed to demonstrate within engine limitation (Exhaust back pressure test results are available on TIB-119)

Models Covered: **100REOZJF**
Model Tested: **100REOZJE**
Cooling System Tested: **50C**

Alternator Tested: **4S9**
Engine Tested: **4045HF285L**
Voltage Tested: **208V**

ALTERNATOR

Alternator temperature rise test per NEMA MG1-32.6. Standby and prime ratings of the alternator are established during this test.

Alternator overload test per NEMA MG1-32.8. Motor starting tests per NEMA MG1-32.18.5 to evaluate capabilities of generator, exciter, and regulator system.

Three-phase symmetrical short-circuit test per NEMA MG1-32.13 to demonstrate short circuit performance, mechanical integrity, ability to sustain short-circuit current.

Harmonic analysis, voltage waveform deviation per NEMA MG1-32.10 to confirm that the generator set is producing clean voltage within acceptable limits.

(Alternator detailed test results are available on TIB-102)

Kohler Standby/Prime Generator Set Test Program

Testing is an integral part of quality assurance. In keeping with our uncompromising commitment to quality, safety, and reliability, every Kohler Standby/Prime power generator set undergoes an extensive series of prototype and production testing.

Prototype Testing

Prototype testing includes the potentially destructive tests necessary to verify design, proper function of protective devices and safety features, and reliability expectations. Kohler's prototype testing includes the following:

- Alternator temperature rise test per NEMA MG1-32.6. Standby and prime ratings of the alternator are established during this test.
- Maximum power test to assure that the prime mover and alternator have sufficient capacity to operate within specifications.
- Alternator overload test per NEMA MG1-32.8.
- Steady-state load test to ensure voltage regulation meets or exceeds ANSI C84.1, NEMA MG1-32.17 requirements and to verify compliance with steady-state speed control specifications.
- Transient test to verify speed controls meets or exceeds specifications.
- Transient load tests per NEMA MG1-32.18, and ISO 8528 to verify specifications of transient voltage regulation, voltage dip, voltage overshoot, recovery voltage, and recovery time.
- Motor starting tests per NEMA MG1-32.18.5 to evaluate capabilities of generator, exciter, and regulator system.
- Three-phase symmetrical short-circuit test per NEMA MG1-32.13 to demonstrate short circuit performance, mechanical integrity, ability to sustain short-circuit current.
- Harmonic analysis, voltage waveform deviation per NEMA MG1-32.10 to confirm that the generator set is producing clean voltage within acceptable limits.

Torsional analysis data, to verify torsional effects are not detrimental and that the generator set will provide dependable service as specified, is available upon request.

Kohler offers other testing at the customer's request at an additional charge. These optional tests include power factor testing, customized load testing for specific application, witness testing, and a broad range of MIL-STD-705c testing. A certified test report is also available at an additional charge.

- Generator set cooling and air flow tests to verify maximum operating ambient temperature.
- Reliability tests to demonstrate product durability, followed by root cause analysis of discovered failures and defects. Corrective action is taken to improve the design, workmanship, or components.
- Acoustical noise intensity and sound attenuation effects tests.

Production Testing

In production, Kohler Standby/Prime generator sets are built to the stringent standards established by the prototype program. Every Kohler generator set is fully tested prior to leaving the factory. Production testing includes the following:

- Stator and exciter winding high-potential test on all generators. Surge transient tests on stators for generators 180 kW or larger. Continuity and balance tests on all rotors.
- One-step, full-load pickup tests to verify that the performance of each generator set, regulator, and governor meets published specifications.
- Regulation and stability of voltage and frequency are tested and verified at no load, 1/4 load, 1/2 load, 3/4 load, and full-rated load.
- Voltage, amperage, frequency and power output ratings verified by full-load test.
- The proper operation of controller logic circuitry, prealarm warnings, and shutdown functions is tested and verified.
- Any defect or variation from specification discovered during testing is corrected and retested prior to approval for shipment to the customer.

KOHLER®

KOHLER CO. Kohler, Wisconsin 53044
Phone 920-565-3381, Fax 920-459-1646
For the nearest sales/service outlet in the
US and Canada, phone 1-800-544-2444
KohlerPowerSystems.com