

Generator

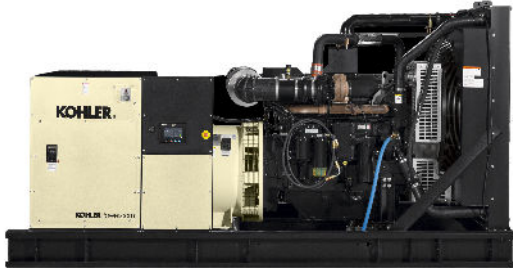

Kohler Model: 300REOZJ

This diesel generator set equipped with a 4UA13 alternator operating at 120/208 volts is rated for 300 kW/375 kVA. Output amperage: 1041

Standard Features:

- Kohler Co. provides one-source responsibility for the generating system and accessories.
- Approved for use with certified renewable Hydrotreated Vegetable Oil (HVO) / Renewable Diesel (RD) fuels compliant with EN15940/ASTM D975.
- The generator set and its components are prototype-tested, factory-built, and production-tested.
- The 60 Hz generator set offers a UL 2200 listing.
- The generator set accepts rated load in one step.
- The 60 Hz generator set meets NFPA 110, Level 1, when equipped with the necessary accessories and installed per NFPA standards.
- A one-year limited warranty covers all systems and components. Two- and five-year extended warranties are also available.
- Tier 3 EPA-certified for Stationary Emergency Applications
- Alternator Protection
- Battery Rack and Cables
- Customer Connection (standard with Decision-Maker 6000 controller only)
- Local Emergency Stop Switch
- Oil Drain Extension
- Operation and Installation Literature

Other Features:

- Kohler designed controllers for one-source system integration and remote communication.
- The low coolant level shutdown prevents overheating (standard on radiator models only). Integral vibration isolation eliminates the need for under-unit vibration spring isolators.
- An electronic, isochronous governor delivers precise frequency regulation.
- Mount up to three circuit breakers to allow circuit protection of selected priority loads.

Alternator Features:

- The unique Fast-Response II excitation system delivers excellent voltage response and short circuit capability using a permanent magnet (PM)-excited alternator.
- The brushless, rotating-field alternator has broad range reconnectability.

Qty

Description

300REOZJ Generator System

1

300REOZJ Generator Set

Includes the following:

Literature Languages	English
Approvals and Listings	UL2200 Listing
Approvals and Listings	IBC Seismic Certification
Engine	300REOZJ, 24V, 60Hz
Nameplate Rating	Standby 130C Rise
Voltage	60Hz, 120/208V, Wye, 3Ph, 4W
Alternator	4UA13
Cooling System	Unit Mounted Radiator, 50C
Skid and Mounting	Skid
Air Intake	Standard Duty
Controller	APM603
Enclosure Type	Sound
Enclosure Material	Steel
Enclosure Silencer	Internal Silencer
Fuel Tank Type	State
Fuel Runtime (Approx.)	24 Hours
Subbase Fuel Tank Capacity	555 Gallons
Fill Pipe/Spill Fill Options	5 Gal Spill Cont w/95% Shutoff
Fuel Tank Vent	Norm Vent 12' & E-Vent 5", IBC
Tank Marking Options	Combust Lqds - Keep Fire Away
Tank Marking Options	NFPA 704 Identification
Tank Marking Options	Tank Number & Safe Fill Height
Starting Aids, Installed	2500W,90-120V,1Ph,w/Valves
Electrical Accy.,Installed	Battery, 2/12V, Wet
Electrical Accy.,Installed	Battery Charger, 10A
Electrical Accy.,Installed	Run Relay
Electrical Accy.,Installed	15 Relay I/O Board
Rating, LCB 1	100% Rated
Amps, LCB 1	1200
Trip Type, LCB 1	Electronic, LSI
Interrupt Rating LCB 1	35kA at 480V
Ground Fault Relay Indication	Ground Fault Relay Indication
Fuel Lines, Installed	Flexible Fuel Lines
Exceeds LTL Shipping Height	Add'l Shipping Charge Accepted
Miscellaneous Accy,Installed	Air Cleaner Restriction Ind.

	Miscellaneous Accy,Installed	Coolant in Genset
	Miscellaneous Accy,Installed	Skid Extension & Caps
	Warranty	Standard
	Testing, Additional	Power Factor Test,0.8,3Ph Only
1	NEC Remote, E-Stop	
1	Lit Kit, Gen Maint, 300REOZJ	
1	RSA III, Annunciator only	

KOHLER®

Spec Sheets

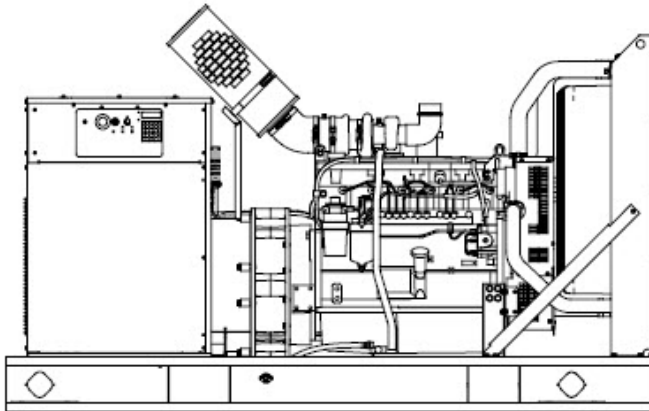

Standard Features

- Kohler Co. provides one-source responsibility for the generating system and accessories.
- Approved for use with certified renewable Hydrotreated Vegetable Oil (HVO) / Renewable Diesel (RD) fuels compliant with EN15940/ASTM D975.
- The generator set and its components are prototype-tested, factory-built, and production-tested.
- The 60 Hz generator set offers a UL 2200 listing.
- The generator set accepts rated load in one step.
- The 60 Hz generator set meets NFPA 110, Level 1, when equipped with the necessary accessories and installed per NFPA standards.
- A one-year limited warranty covers all systems and components. Two- and five-year extended warranties are also available.
- Tier 3 EPA-certified for Stationary Emergency Applications
- Alternator Protection
- Battery Rack and Cables
- Customer Connection (standard with Decision-Maker 6000 controller only)
- Local Emergency Stop Switch
- Oil Drain Extension
- Operation and Installation Literature

Alternator Features

- The unique Fast-Response II excitation system delivers excellent voltage response and short circuit capability using a permanent magnet (PM)-excited alternator.
- The brushless, rotating-field alternator has broad range reconnectability.

Other Features

- Kohler designed controllers for one-source system integration and remote communication.
- The low coolant level shutdown prevents overheating (standard on radiator models only). Integral vibration isolation eliminates the need for under-unit vibration spring isolators.
- An electronic, isochronous governor delivers precise frequency regulation.
- Mount up to three circuit breakers to allow circuit protection of selected priority loads.

Generator Set Rating

Standby 130C Rise Ratings

Alternator	Voltage	Ph	Hz	kW/kVA	Amps
4UA13	120/208	3	60	300/375	1041

Model: 300REOZJ, continued

Alternator Specifications

Specifications	Alternator
Alternator manufacturer	Kohler
Type	4-Pole, Rotating-Field
Exciter type	Brushless, Permanent-Magnet
Leads, quantity	12, Reconnectable
Voltage regulator	Solid State, Volts/Hz
Insulation	NEMA MG1
Insulation: Material	Class H
Insulation: Temperature Rise	130 ° C, Standby
Bearing: quantity, type	1, Sealed
Coupling	Flexible disc
Amortisseur windings	Full
Voltage regulation, no-load to full-load (with <0.5% drift due to temp. variation)	Controller Dependent
One-Step Load Acceptance	100% of rating
Unbalanced load capability	100% of Rated Standby Current
<ul style="list-style-type: none"> • NEMA MG1, IEEE, and ANSI standards compliance for temperature rise and motor starting. • Sustained short-circuit current of up to 300% of the rated current for up to 10 seconds. 	
<ul style="list-style-type: none"> • Sustained short-circuit current enabling down stream circuit breakers to trip without collapsing the alternator field. <ul style="list-style-type: none"> • Self-ventilated and dripproof construction. 	
<ul style="list-style-type: none"> • Vacuum-impregnated windings with fungus-resistant epoxy varnish for dependability and long life. <ul style="list-style-type: none"> • Superior voltage waveform from a two-thirds pitch stator and skewed rotor. • Fast-Response™ II brushless alternator with brushless exciter for excellent load response. 	

Engine

Engine Specification

Engine Manufacturer	John Deere
Engine Model	6090HFG86
Engine: type	4-Cycle, Turbocharged, Charge Air Cooled
Cylinder arrangement	6, Inline
Displacement, L (cu. in.)	9.0 (548)
Bore and stroke, mm (in.)	118.4 x 136 (4.65 x 5.35)
Compression ratio	16.0:1
Piston speed, m/min. (ft./min.)	457 (1500)
Main bearings: quantity, type	7, Replaceable Insert
Rated rpm	1800
Max. power at rated rpm, kWm (BHP)	345 (463)
Cylinder head material	Cast Iron
Crankshaft material	Forged Steel
Valve (exhaust) material Intake	Chromium-Silicon Steel
Valve (exhaust) material	Stainless Steel
Governor: type, make/model	JDEC Electronic L14 Denso HP4
Frequency regulation, no-load to-full load	Isochronous
Frequency regulation, steady state	± 0.25%
Frequency	Fixed
Air cleaner type, all models	Dry

Model: 300REOZJ, continued

Exhaust

Exhaust System

Exhaust Manifold Type	Dry
Exhaust flow at rated kW, m ³ /min. (cfm)	63.6 (2246)
Exhaust temperature at rated kW, dry exhaust, °C (°F)	497 (927)
Maximum allowable back pressure, kPa (in. Hg)	Min. 0 (0) Max. 7.5 (2.2)
Exh. outlet size at eng. hookup, mm (in.)	98 (3.86)

Engine Electrical

Engine Electrical System

Battery charging alternator: Ground (negative/positive)	Negative
Battery charging alternator: Volts (DC)	24
Battery charging alternator: Ampere rating	45
Starter motor rated voltage (DC)	24
Battery, recommended cold cranking amps (CCA): Qty., CCA rating each	Two, 925
Battery voltage (DC)	12

Fuel

Fuel System

Fuel type	Diesel
Fuel supply line, min. ID, mm (in.)	11.0 (0.44)
Fuel return line, min. ID, mm (in.)	6.0 (0.25)
Max. lift, fuel pump: type, m (ft.)	Electronic, 3 (10)
Max. fuel flow, Lph (gph)	240 (63.4)
Fuel prime pump	Electronic
Fuel Filter Secondary	2 Microns@ 98% Efficiency
Fuel Filter Primary	10 Microns
Fuel Filter Water Separator	Yes
Recommended fuel	#2 Diesel/HVO/RD

Lubrication

Lubrication System

Type	Full Pressure
Oil pan capacity, L (qt.)	32.5 (34.4)
Oil pan capacity with filter, L (qt.)	33.4 (35.3)
Oil filter: quantity, type	1, Cartridge
Oil cooler	Water-Cooled

Model: 300REOZJ, continued

Cooling

Radiator System

Ambient temperature, ° C (° F)	50 (122)
Engine jacket water capacity, L (gal.)	16 (4.25)
Radiator system capacity, including engine, L (gal.)	36 (9.5)
Engine jacket water flow, Lpm (gpm)	265 (70)
Heat rejected to cooling water at rated kW, dry exhaust, kW (Btu/min.)	114 (6489)
Heat rejected to air charge cooler at rated kW, dry exhaust, kW (Btu/min.)	99.1 (5641)
Water pump type	Centrifugal
Fan diameter, including blades, mm (in.)	863.6 (34.0)
Fan, kWm (HP)	9 (12.1)
Max. restriction of cooling air, intake and discharge side of radiator, kPA (in. H2O)	0.125 (0.5)

* Enclosure with internal silencer reduces ambient temperature capability by 5 ° C (9 ° F).

Operation Requirements

Air Requirements

Radiator-cooled cooling air, m3/min. (scfm) *	396.4 (14000)
Combustion air, m3/min. (cfm)	26.5 (936)
Heat rejected to ambient air: Engine, kW (Btu/min.)	60.8 (3460)
Heat rejected to ambient air: Alternator, kW (Btu/min.)	23.9 (1360)

*Air density = 1.20 kg/m3 (0.075 lbm/ft3)

Fuel Consumption

Diesel, Lph (gph), at % load

Rating

Standby Fuel Consumption at 100% load	84.1 Lph (22.2 gph)
Standby Fuel Consumption at 75% load	67.7 Lph (17.9 gph)
Standby Fuel Consumption at 50% load	49.7 Lph (13.1 gph)
Standby Fuel Consumption at 25% load	26.3 Lph (7.0 gph)
Continuous Fuel Consumption at 0% load	

** Volumetric Fuel consumption is up to 4% higher when using HVO/RC than #2 ULSD.



The APM603 generator set controller provides advanced control, system monitoring, and system diagnostics for a single generator set or paralleling multiple generator sets. The APM603 interfaces the generator set to other power system equipment and network management systems using standard industry network communications. It uses a patented digital voltage regulator and unique software logic to manage alternator thermal overload protection as well as serves as an overcurrent protective relay, features normally requiring additional hardware. The APM603 controller meets NFPA 110, Level 1.

Display, Interface, and Accessibility

- A 7-inch color TFT touchscreen for easy local access to data.
 - Home screen can be customized to show critical data at a glance.
 - Create a custom favorites list for quick access to important data
- Measurements are selectable in metric or English units.
- Supports Modbus® protocol through serial bus and Ethernet networks, and supports SNMP and BACnet® through Ethernet networks.

Global Support

- Sales, installation, and service support from more than 800 Kohler and SDMO service providers around the world.

On-board Diagnostics

- Immediate visibility of warnings and faults with text description and code display.
 - 15 seconds of critical data are captured around each warning and fault
 - Critical data can be viewed on the display and downloaded
- Store up to 10,000 events locally along with historical data logging of successful starts.
 - Accurate time stamp from real-time clock
 - Event log can be downloaded
- Data logging of customized parameter list for report generation and advanced troubleshooting.
 - Store to external USB drive for easy transfer to another device

Modbus® is a registered trademark of Schneider Electric.
BACnet® is a registered trademark of ASHRAE.

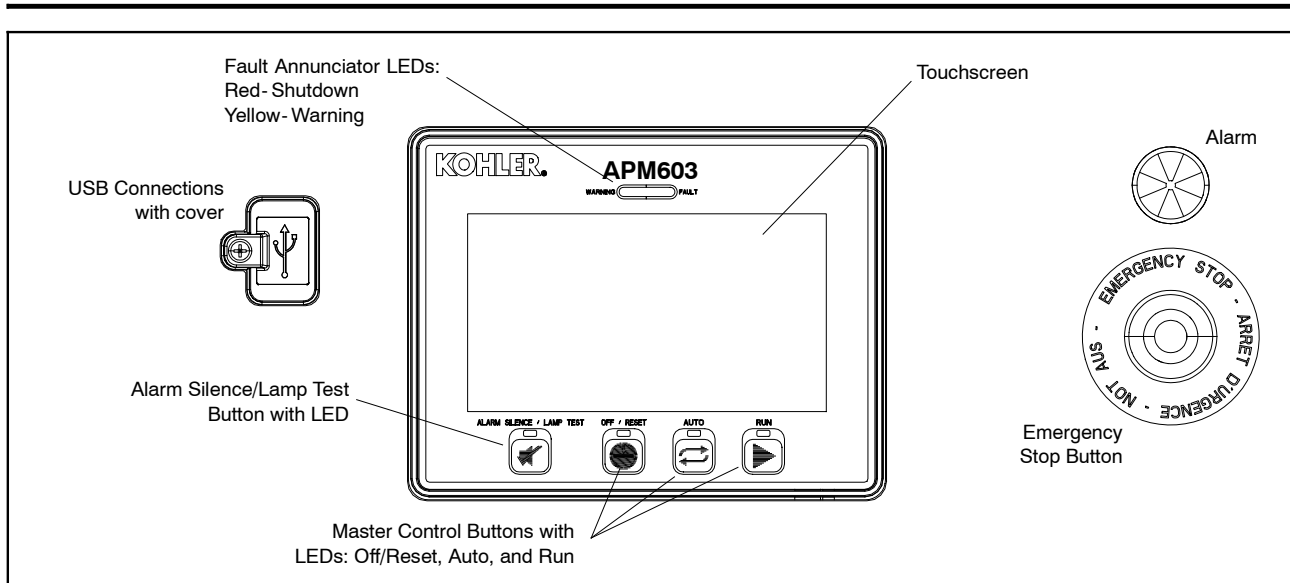

Controller Features

AC Output Voltage Regulator Adjustment	Maximum of $\pm 10\%$ of the system voltage
Alarm Horn	Indicates a generator set warning or shutdown condition
Alarm Silence	For NFPA-110 application or user convenience
Alternator Protection	Generator set overload and short circuit protection
Cyclic Cranking	Provides automatic restart after a failed start attempt with programmable on/off time and number of attempts
ECU Diagnostics	Displays engine ECU fault codes and descriptions for engine troubleshooting
Emergency Stop Button	Shuts down the generator set immediately, for emergency situations
Engine Start Aid	Control for an optional engine starting aid
Environmentally Sealed Membrane Keypad	Three master control buttons with LEDs: Off/Reset, Auto, and Run
Patented High-Speed RMS Digital Voltage Regulator	$\pm 0.25\%$ no-load to full-load regulation with three-phase true RMS sensing
Lamp Test	Verifies functionality of the indicator LEDs
Real-time Clock	Includes battery back-up to retain date and time through controller power cycle
Remote Reset	Allows remote fault resets and restarting of the generator set
Remote Monitoring Panel	Compatible with the Kohler® Remote Serial Annunciator
Run Time Hourmeter	Displays generator set run time
Run Relay	Indicates that the generator set is running
Time Delay Engine Cooldown (TDEC)	Time delay before the generator set shuts down
Time Delay Engine Start (TDES)	Time delay before the generator set starts

Communication

USB Port	(1) Mini-USB port for PC connection (1) USB port for storage device
Serial (RS-485) Port	(1) Non-isolated for RSA III (1) Isolated for Modbus devices (1) Isolated for paralleling communication
Ethernet Port	(1) RJ45 for Modbus TCP, SNMP, and BACnet

Controller Specifications

Nominal voltage	12 or 24 VDC protected against reverse battery connection
Power	800 mAmps at 12 VDC 400 mAmps at 24 VDC
Operating Temperature	-40°C to 70°C (-40°F to 158°F)
Storage Temperature	-40°C to 85°C (-40°F to 185°F)
Humidity	5% to 95% non-condensing
Display Size, W x H	154 x 86 mm (6.0 x 3.4 inches)
Protection Index	IP65 Front

Paralleling Features

- Isochronous control with real and reactive load sharing with other APM603 controller equipped generator sets
 - Supports paralleling up to 8 generators
- Random first-on logic to prevent two or more generator sets from closing to a dead bus and provides the fastest response for a single generator online
- Automatic synchronizer with dead bus closing
- Soft loading and unloading for generator management
- Protective relay functions:
 - Synch check (25C)
 - Over current (51)
 - Over frequency (81O)
 - Over power (32O)
 - Over voltage (59)
 - Reverse power (32R)
 - Reverse reactive power (32RQ)
 - Under frequency (81U)
 - Under voltage (27)
- Generator management to allow the start and stop of generators based on load demand or state of other generators
 - Fuel level
 - Run time
 - Manual order
 - Time of day
 - Efficiency
- Simplified paralleling system view from any generator controller in the system

Overcurrent Protective Device

- Provides protection against line-to-line and line-to-neutral faults
- Uses thermal and instantaneous current limit settings for alternator protection
- Includes a maintenance mode for arc flash reduction per NEC 240.87

Load Management Features

- Programmable outputs included to command the connect and disconnect of loads based on generator or paralleling system state
 - Loads connected based on available capacity
 - Loads disconnected at system startup
 - Loads disconnected based on a maximum kW setting or underfrequency setting
- Supports up to 16 prioritized load steps per system
 - Can be used on a single generator system
 - Can be combined in a paralleling system for a total system load control capability
- Simplified load management system view from any generator controller in the system
- Requires input/output module option

Advanced Programmable I/O

- Configurable inputs and outputs can be programmed for customer specific use
- PLC-like capability for applying logic to customize generator system behavior

Troubleshooting Features

- 15 seconds of key data automatically captured around each warning and shutdown
 - Data can be exported for detailed analysis
 - Data can be viewed on controller for convenient on-site troubleshooting support
- Configurable data logger will allow you to select parameters to monitor
 - Data stored to USB device for flexibility on amount of data stored and ability to export for detailed analysis
 - Data capture controlled by user to allow capturing specific data required

NFPA 110 Requirements

In order to meet NFPA 110, Level 1 requirements, the generator set controller monitors the engine/generator functions/faults shown below.

- Engine functions:
 - Overcrank
 - Low coolant temperature warning
 - High coolant temperature warning
 - High coolant temperature shutdown
 - Low oil pressure shutdown
 - Low oil pressure warning
 - High engine speed
 - Low fuel (level or pressure) *
 - Low coolant level
 - EPS supplying load
 - High battery voltage
 - Low battery voltage
- General functions:
 - Master switch not in auto
 - Battery charger fault *
 - Lamp test
 - Contacts for local and remote common alarm
 - Audible alarm silence button
 - Remote emergency stop *

* Function requires optional input sensors or kits and is engine dependent, see Engine Data.

Standards

The generator set controller has been tested and verified for compliance with the following standards.

- NFPA 99
- NFPA 110, Level 1
- CSA 282-09
- UL 6200
- ASTM B117 (salt spray test)

Controller Functions

The controller displays warning, shutdown, and status messages. **All functions are available as relay outputs.**

Warning causes the yellow fault LED to show and sounds the alarm horn, signaling an impending problem.

Shutdown causes the red fault LED to show, sounds the alarm horn, and stops the generator set.

The controller communicates with the engine ECU and supports a large number of warning and shutdown events that are not listed here. This table highlights the items required for NFPA 110.

Event	Warning	Shutdown
Alternator Thermal Protection †		●
Battery Charger Fault *	▲	
CAN Option Board1 Comm Loss	▲	
Critically Low Fuel Level (diesel) *	▲	
ECU Diagnostic Event	▲	
ECU Mismatch Shutdown †		●
Fuel Leak Alarm (diesel) *	▲	
High Battery Voltage Warning	▲	
High Coolant Temperature Shutdown †		●
High Coolant Temperature Warning	▲	
High Fuel Level Warning (diesel) *	▲	
High Oil Temperature Shutdown †		●
High Oil Temperature Warning	▲	
Local Emergency Stop Shutdown †		●
Loss ECU Comms Shutdown †		●
Loss of Signal Low Coolant Level Voltage	▲	
Low Battery Voltage Warning	▲	
Low Coolant Level Shutdown †		●
Low Coolant Temperature Warning	▲	
Low Fuel Level Shutdown (diesel) * †		●
Low Fuel Level Warning (diesel) *	▲	
Low Fuel Pressure Warning (gas) *	▲	
Low Oil Pressure Shutdown †		●
Low Oil Pressure Warning	▲	
Low RTC (clock) Battery Voltage	▲	
Maintenance Reminder1	▲	
Maintenance Reminder2	▲	
Maintenance Reminder3	▲	
Maximum Power Shutdown †		●
Maximum Power Warning	▲	
Not In Auto Alarm	▲	
Over Crank Shutdown †		●
Over Current Shutdown (L1, L2, L3) †		●
Over Current Warning (L1, L2, L3)	▲	
Over Frequency Shutdown †		●
Over Frequency Warning	▲	
Over Power Shutdown †		●
Over Power Warning	▲	
Over Speed Shutdown †		●
Over Voltage Shutdown (L-L, L-N, each phase) †		●
Over Voltage Warning (L-L, L-N, each phase)	▲	

Event	Warning	Shutdown
Remote Emergency Stop Shutdown †		●
Reverse Power Shutdown †		●
Reverse VAR Shutdown †		●
Under Frequency Shutdown †		●
Under Frequency Warning	▲	
Under Voltage Shutdown (L-L, L-N, each phase) †		●
Under Voltage Warning (L-L, L-N, each phase)	▲	
Weak Cranking Battery	▲	
Status Messages		
Auto Button Pressed		
EPS Supplying Load		
Generator Running		
Generator Started		
Generator Stopped		
GFCI Warning *		
Load Shed Overload		
Load Shed Under Frequency		
Off Button Pressed		
RSA Event Programmable Digital Inputs, 1 - 8		
Run Button Pressed		
* Function requires optional input sensors or kits		
† Items included with common fault shutdown 10		

John Deere Engine-Powered Models Inputs and Outputs

Standard Dedicated User Inputs	Input Type
Auxiliary Fault (Shutdown)	Digital Input
Auxiliary Warning	
Battery Charger Fault	
Breaker Closed *	
Breaker Open *	
Excitation Over Voltage (350 kW and up)	
Fuel Leak Alarm	
Low Fuel Level Switch	
Remote Emergency Stop	
Remote Engine Start	Two-wire input
Speed Bias	Analog Voltage Input, Scalable up to +/- 10 VDC
Voltage Bias	

Standard Dedicated User Outputs	Output Type
Close Breaker *	Relay Driver Output
Common Failure	
Run	
Trip Breaker / Shunt Trip *	
* Only with remote-mounted electrically operated circuit breakers.	

Optional Configurable User Inputs and Outputs	
User Configurable Inputs	2 Analog, 0- 5 VDC 4 Dry Contact Digital
User Configurable Relay Outputs	14 NO/NC Relays 1 Common Fault Relay
Note: Programmable I/O is configurable by a Kohler-authorized technician	

JD Engine Data

The following John Deere engine data is displayed on the APM603 controller.

Parameter
Engine Model Number
Engine Serial Number
ECU Serial Number
Coolant Temperature
Engine Speed
Fuel Pressure
Fuel Consumption Rate
Oil Pressure
Run Time Hours

APM603 Available Options

- Common Failure Relay** provides a relay output to signal a generator set fault.
- Battery Charger** available with 6 amp, 10 amp, and 20 amp output for 12 and 24V DC voltage output. (Availability is generator model dependent.) The 10 amp and 20 amp models provide NFPA 110 charging and alarming capability.
- Electrically Operated Circuit Breakers**
 - For paralleling systems
 - Available generator-mounted or remote-mounted
 - 24VDC
- Ground Fault Relay** provides a relay output to signal a ground fault is detected.
- Input/Output Module** for Kohler Diesel (KD) and Mitsubishi models provides:
 - 16 digital input connections with connection to ground
 - 8 relay output connections (Form C, rated 8A, 240 VAC or rated 0.5 A, 48 VDC)
- Input/Output Module** for models other than KD or Mitsubishi provides:
 - 2 analog inputs (0-5 VDC)
 - 4 digital input connections with connection to ground
 - 14 relay output connections (Form C, rated 10A, 120V)
 - 1 common fault relay output (NO, rated 2A, 24VDC)
- Key Switch** to allow selection of RUN, OFF and AUTO modes. Lockable in the AUTO position by removing the key.
- Remote Emergency Stop Switch** available as a wall mounted panel to remotely shut down the generator set.
- Remote Monitoring Panel.** The Kohler® Remote Serial Annunciator (RSA) enables the operator to monitor the status of the generator set from a remote location, which may be required for NFPA 99 and NFPA 110 installations, and up to four Automatic transfer switches.
- Shunt Trip Wiring** provides relay outputs to trip a shunt trip circuit breaker and to signal the common fault shutdowns. Contacts rated at 10 amps at 28 VDC or 120 VAC.

DISTRIBUTED BY:

Availability is subject to change without notice. Kohler Co. reserves the right to change the design or specifications without notice and without any obligation or liability whatsoever. Contact your local Kohler® generator set distributor for availability.

© 2019 Kohler Co., All rights reserved.

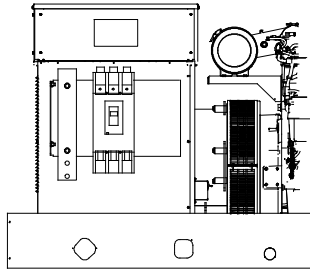

Single Circuit Breaker Kit with Neutral Bus Bar
15-300 kW Model Shown

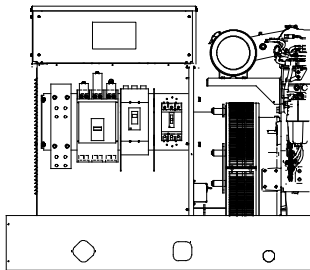

Multiple Circuit Breaker Kit with Neutral Bus Bar
180-300 kW Model Shown

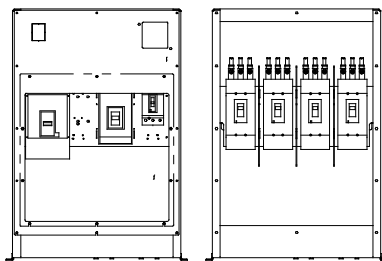

Multiple Circuit Breaker Kits with Neutral Bus Bar
350-2250 kW Model Shown
(also applies to some 300 kW models)

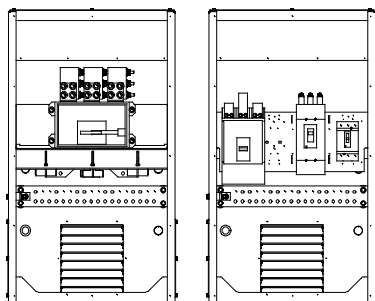

Circuit Breaker Kits with Neutral Bus Bar
700-2500 kW KD Model Shown

Standard Features

- The line circuit breaker interrupts the generator set output during a short circuit and protects the wiring when an overload occurs. Use the circuit breaker to manually disconnect the generator set from the load during generator set service.
- Circuit breaker kits are mounted to the generator set and are provided with load-side lugs and neutral bus bar.
- Kohler Co. offers a wide selection of molded-case line circuit breaker kits including single, dual, and multiple configurations for each generator set.
- Four types of line circuit breakers are available: (see page 2 for definitions and pages 3 and 4 for application details)
 - Magnetic trip
 - Thermal magnetic trip
 - **Electronic trip**
 - Electronic with ground fault (LSIG) trip
- In addition, line circuit breakers are offered with 80% and 100% ratings.
- Single line circuit breaker kits allow circuit protection of the entire electrical system load.
- Dual line circuit breaker kits allow circuit protection of selected priority loads from the remaining electrical system load.
- Multiple line circuit breaker kits with field connection barrier allow circuit protection for special applications (350-2500 kW models and selected 80-300 kW models).
- Up to four line circuit breakers can be used on 350-2500 kW models.
- Line circuit breakers comply with the following codes and standards unless otherwise stated.
 - UL 489 Molded Case Circuit Breakers
 - UL 1077 Supplementary Protectors
 - UL 2200 Stationary Engine Generator Assemblies

Line Circuit Breaker Types

Magnetic Trip

The magnetic trip features an electromagnet in series with the load contacts and a moveable armature to activate the trip mechanism. When a sudden and excessive current such as a short circuit occurs, the electromagnet attracts the armature resulting in an instantaneous trip.

Thermal Magnetic Trip

Thermal magnetic trip contains a thermal portion with a bimetallic strip that reacts to the heat produced from the load current. Excessive current causes it to bend sufficiently to trip the mechanism. The trip delay is dependent on the duration and excess of the overload current. Elements are factory-calibrated. A combination of both thermal and magnetic features allows a delayed trip on an overload and an instantaneous trip on a short circuit condition.

Electronic Trip

These line circuit breakers use electronic controls and miniature current transformers to monitor electrical currents and trip when preset limits are exceeded.

LI breakers are a combination of adjustable trip functions including long-time ampere rating, long-time delay, and instantaneous pickup. LSI breakers have all of the LI breaker features plus short-time pickup, short-time delay, and defeatable instantaneous pickup. LSIG breakers have all of the LSI breaker features plus ground-fault pickup and delay.

NOTE: MG-frame does not have a long-time delay when selected with LI breakers.

Electronic with Ground Fault Trip

The ground fault trip feature is referred to as LSIG in this document. Models with LSIG compare current flow in phase and neutral lines, and trip when current unbalance exists.

Ground fault trip units are an integral part of the circuit breaker and are not available as field-installable kits. The ground fault pickup switch sets the current level at which the circuit breaker will trip after the ground fault delay. Ground fault pickup values are based on circuit breaker sensor plug only and not on the rating plug multiplier. Changing the rating plug multiplier has no effect on the ground fault pickup values.

80% Rated Circuit Breaker

Most molded-case circuit breakers are 80% rated devices. An 80% rated circuit breaker can only be applied at 80% of its rating for continuous loads as defined by NFPA 70. Circuit conductors used with 80% rated circuit breakers are required to be rated for 100% of the circuit breaker's rating.

The 80% rated circuit breakers are typically at a lower cost than the 100% rated circuit breaker but load growth is limited.

100% Rated Circuit Breaker

Applications where all UL and NEC restrictions are met can use 100% rated circuit breakers where 100% rated circuits can carry 100% of the circuit breaker and conductor current rating.

The 100% rated circuit breakers are typically at a higher cost than the 80% rated circuit breaker but have load growth possibilities.

When applying 100% rated circuit breakers, comply with the various restrictions including UL Standard 489 and NEC Section 210. If any of the 100% rated circuit breaker restrictions are not met, the circuit breaker becomes an 80% rated circuit breaker.

Line Circuit Breaker Options

Alarm Switch

The alarm switch indicates that the circuit breaker is in a tripped position caused by an overload, short circuit, ground fault, the operation of the shunt trip, an undervoltage trip, or the push-to-trip pushbutton. The alarm resets when the circuit breaker is reset.

Auxiliary Contacts

These switches send a signal indicating whether the main circuit breaker contacts are in the open or closed position.

Breaker Separators (350-2500 kW)

Provides adequate clearance between breaker circuits.

Bus Bars

Bus bar kits offer a convenient way to connect load leads to the generator set when a circuit breaker is not present. **15-300 kW.** Bus bar kits are available on alternators with leads for connection to the generator set when circuit breakers are not ordered.

350-2500 kW. A bus bar kit is provided when no circuit breaker is ordered. Bus bars are also available in combination with circuit breakers or other bus bars on the opposite side of the junction box. On medium voltage (3.3 kV and above) units, a bus bar kit is standard (not applicable to KD models).

Field Connection Barrier

Provides installer wiring isolation from factory connections.

Ground Fault Annunciation

A relay contact for customer connection indicates a ground fault condition and is part of a ground fault alarm.

Lockout Device (padlock attachment)

This field-installable handle padlock attachment is available for manually operated circuit breakers. The attachment can accommodate three padlocks and will lock the circuit breaker in the OFF position only.

Lugs

Various lug sizes are available to accommodate multiple cable sizes for connection to the neutral or bus bar.

Overcurrent Trip Switch

The overcurrent trip switch indicates that the circuit breaker has tripped due to overload, ground fault, or short circuit and returns to the deenergized state when the circuit breaker is reset.

Shunt Trip, 12 VDC or 24 VDC

A shunt trip option provides a solenoid within the circuit breaker case that, when momentarily energized from a remote source, activates the trip mechanism. This feature allows the circuit breaker to be tripped by customer-selected faults such as alternator overload or overspeed. The circuit breaker must be reset locally after being tripped. Tripping has priority over manual or motor operator closing.

Shunt Trip Wiring

Connects the shunt trip to the generator set controller. (standard on KD models with the APM802 controller)

Undervoltage Trip, 12 VDC or 24 VDC

The undervoltage trips the circuit breaker when the control voltage drops below the preset threshold of 35%-70% of the rated voltage.

15- 300* kW Line Circuit Breaker Specifications

* Includes models 300REOZJ and 300REZXC. For other 300 kW models, see the 300- 2250 kW section.

100% Rating Circuit Breaker

Alt. Model	Ampere Range	Trip Type	C. B. Frame Size		
4D/4E	15- 150	Thermal magnetic	HD		
		Electronic LI			
		Electronic LSI			
	60- 150	Electronic LSI		HG	
		Electronic LSI			
		Electronic LSI			
4P/4PX 4Q/4QX	15- 150	Thermal magnetic	HD		
		Electronic LI			
		Electronic LSI			
	60- 150	Electronic LSI		HG	
		Electronic LSI			
		Electronic LSI			
	175- 250	Thermal magnetic	JD		
		Electronic LI			
		Electronic LSI			
	250	250	Electronic LSI	JD	
			Electronic LSI		
			Electronic LSI		
		250	Electronic LI	JG	
			Electronic LSI		
			Electronic LSI		
	400	400	Electronic LI	LG	
			Electronic LSI		
			Electronic LSI		
4RX 4S/4SX 4TX 4V 4UA 4M6226		15- 150	Thermal magnetic		HD
			Electronic LI		
			Electronic LSI		
	60- 150	Electronic LSI	HG		
		Electronic LSI			
		Electronic LSI			
	175- 250	Thermal magnetic		JD	
		Electronic LI			
		Electronic LSI			
	250	250	Electronic LSI	JG	
			Electronic LSI		
			Electronic LSI		
		400	400	Electronic LI	LG
				Electronic LSI	
				Electronic LSI	
	600- 800		Electronic LSI	PG	
			Electronic LSI		
			Electronic LSI		
4UA 4M6226	1000- 1200	Electronic LSI	PG		
		Electronic LSI			
	1200	Electronic LSI	PJ		
		Electronic LSI			

100% Rating Electrically Operated Breakers

For use as paralleling breakers with the Decision-Maker® 6000 Controller/DPS System or APM603 controller.

Generator-Mounted P-Frame, 24VDC Electrically Operated			
Alt. Model	Amps	Trip Unit	Frame
4RX 4S/4SX 4TX 4V	250	3.0 LI	PJ
	400	5.0 LSI	PJ
	600	3.0 LI	PL
	800	5.0 LSI	PL
4UA 4M6226	250	3.0 LI	PJ
	400	5.0 LSI	PJ
	600	3.0 LI	PL
	800	5.0 LSI	PL
	1200	5.0 LSI	PL

All circuit breakers listed in this table include line side bus and load side lugs, 24VDC motor operators, 2 type C auxiliary contacts, and 1 type C SDE overcurrent switch contact. No second breakers are allowed in combination with these breakers.

Interrupting Ratings

Circuit Breaker Frame Size	240 Volt, kA	480 Volt, kA	600 Volt, kA
HD	25	18	14
HG	65	35	18
HJ	100	65	25
JD	25	18	14
JG	65	35	18
JJ	100	65	25
LA	42	30	22
LG	65	35	18
MG			
PG	65	35	18
PJ	100	65	25
PL	125	100	25

Circuit Breaker Lugs Per Phase (Al/Cu)

Frame Size	Ampere Range	Wire Range
E (480 V max.)	30- 100	Up to two wire terminals fitting 10-32 or 1/4-20 stud
H	15- 150	One #14 to 3/0
J	175	One 1/0 to 4/0
	200- 250	One 3/0 to 350 kcmil
LA	300- 400	One #1 to 600 kcmil or Two #1 to 250 kcmil
LG	400- 600	Two 2/0 to 500 kcmil AL/CU
M	800	Three 3/0 to 500 kcmil
P	600-800	Three 3/0 to 500 kcmil
	1000-1200	Four 3/0 to 500 kcmil
Mechanical Load Lugs Included with H, J, and LG LSI Neutrals		
H	60- 150	One #14 to 3/0 AL/CU
J	250	One 3/0 to 350 kcmil AL/CU
LG	400- 600	Two 4/0 to 500 kcmil AL/CU

15- 300* kW Line Circuit Breaker Applications

* Includes models 300REOZJ and 300REZXC. For other 300 kW models, see the 300- 2250 kW section.

Single Circuit Breaker Installations

A generator set with a single circuit breaker installed typically feeds a single transfer switch and then a distribution panel. This allows protection of the entire system.

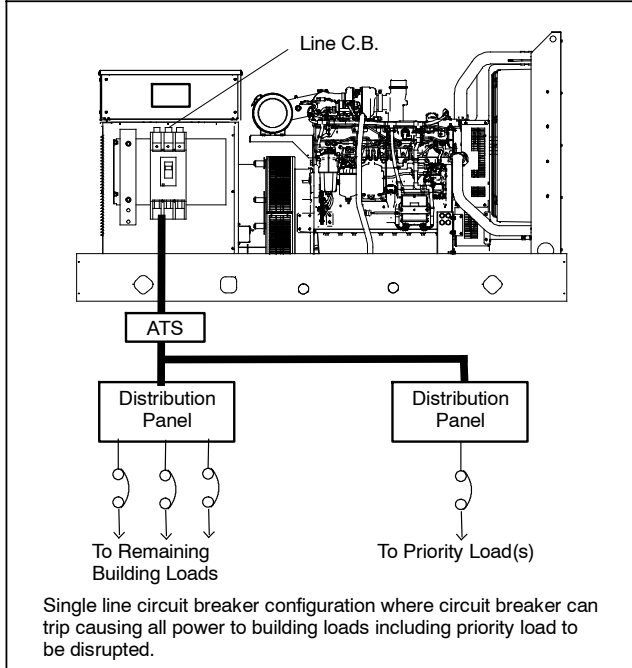

Multiple Circuit Breaker Installations

A generator set with dual circuit breakers installed is used to separate critical loads. Typically, one circuit breaker will feed a main transfer switch with noncritical loads and the other circuit breaker will feed a second transfer switch that feeds critical or priority loads. Multiple circuit breakers allow circuit protection for special applications.

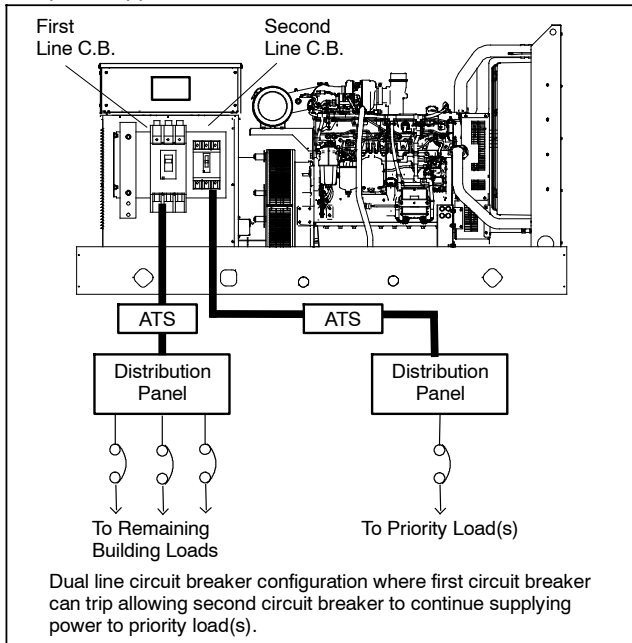

Circuit Breaker Combinations

Alternator Model	First C. B. Frame	Second C. B. Frame	Third C. B. Frame	Trip Type
ALL except 4D/4E	H	—	—	All
	J	—	—	
	LA	—	—	
	LG	—	—	
4D/4E	H	—	—	Standard or LSIG
	H	H	—	No LSIG
4P/4PX 4Q/4QX	H	H or J	—	No LSIG
	J		—	
	LA	—		
	LG	H, J or LG	—	
4RX 4S/4SX 4TX 4V	M	—	—	All
	P	—	—	All
	H or J	H or J	—	No LSIG
	LA	H, J, or LA	—	
	LG	H, J, LA, or LG	—	
	M		—	
	P	—	—	
H or J	H or J	H or J		
4UA 4M6226	M or P	—	—	All
	H or J	H or J	—	All
	LA	H, J, or LA	—	
	LG	H, J, LA, or LG	—	
	M or P	H, J, LA, or LG	—	
	P	P	—	
	H or J	H or J	H or J	
	LA	H or J	H or J	
		LA	H, J, or LA	
	LG	H or J	H or J	
LA		H, J, or LA		
M or P	LA	H, J, or LA		
	LG	H, J, or LG		

CURRENT IN MULTIPLES OF I_r ($I_r = \text{LONG-TIME SETTING} \times I_n$)

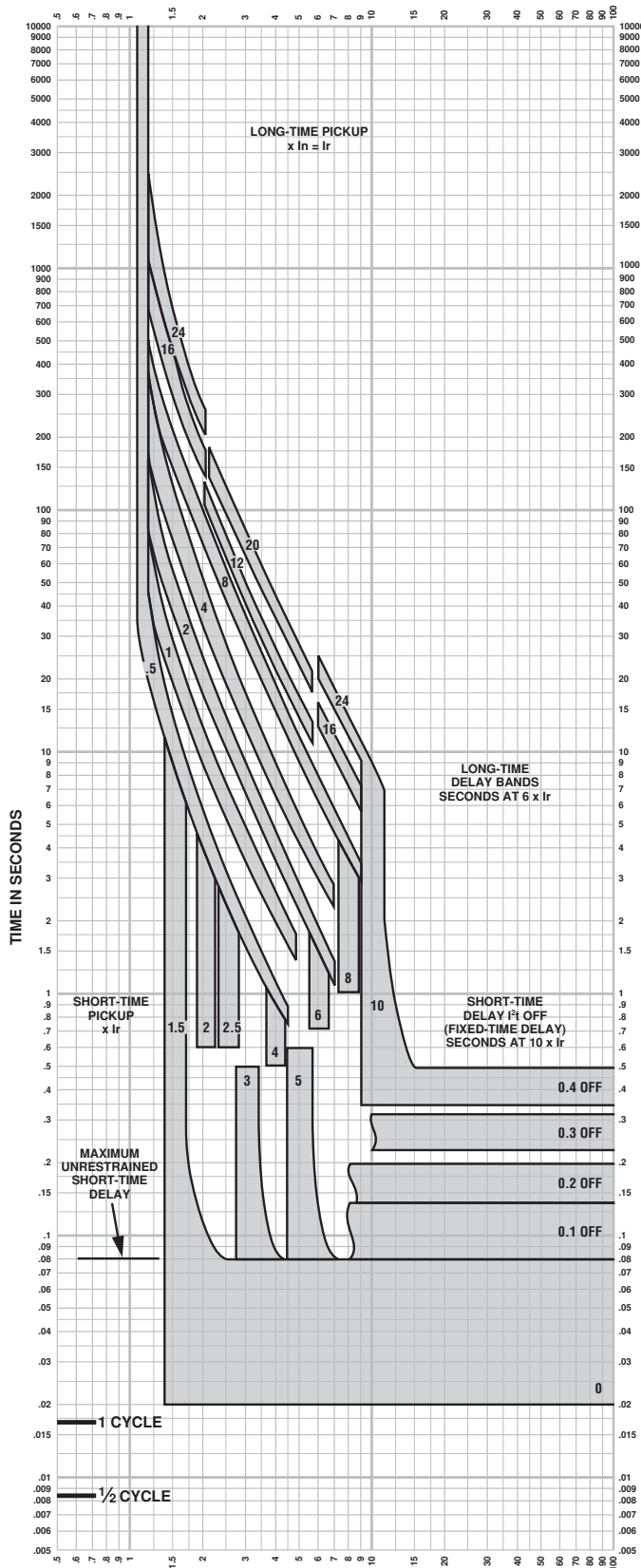

**MICROLOGIC® 5.0/6.0 A/P/H TRIP UNIT
CHARACTERISTIC TRIP CURVE NO. 613-4**

Long-time Pickup and Delay
Short-time Pickup and I^2t OFF Delay

The time-current curve information is to be used for application and coordination purposes only.

Curves apply from -30°C to $+60^{\circ}\text{C}$ ambient temperature.

Notes:

1. There is a thermal-imaging effect that can act to shorten the long-time delay. The thermal-imaging effect comes into play if a current above the long-time delay pickup value exists for a time and then is cleared by the tripping of a downstream device or the circuit breaker itself. A subsequent overload will cause the circuit breaker to trip in a shorter time than normal. The amount of time delay reduction is inverse to the amount of time that has elapsed since the previous overload. Approximately 20 minutes is required between overloads to completely reset thermal-imaging.
2. The end of the curve is determined by the interrupting rating of the circuit breaker.
3. With zone-selective interlocking on, short-time delay utilized and no restraining signal, the maximum unrestrained short-time delay time band applies regardless of the setting.
4. Total clearing times shown include the response times of the trip unit, the circuit breaker opening, and the extinction of the current.
5. For a withstand circuit breaker, instantaneous can be turned OFF. See 613-7 for instantaneous trip curve. See 613-10 for instantaneous override values.
6. Overload indicator illuminates at 100%.

- Merlin Gerin
 - Modicon
 - Square D
 - Telemecanique
 - Federal Pioneer
 - Federal Pacific
- Schneider Electric Brands



© 2000 Schneider Electric. all rights reserved

Curve No. 0613TC0004
December 2000
Drawing No. B48095-613-04

CURRENT IN MULTIPLES OF I_r
($I_r = \text{LONG-TIME SETTING} \times I_n$)



Typical Overall Dimensions

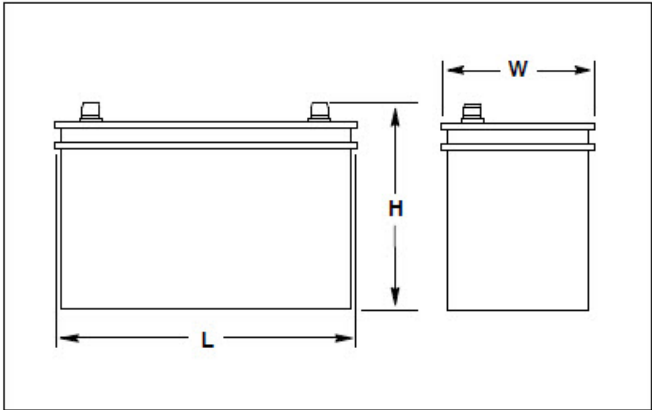

Standard Features

- Kohler Co. selects batteries to meet the engine manufacturer's specifications and to comply with NFPA requirements for engine-cranking cycles.
- Heavy-duty starting batteries are the most cost-effective means of engine cranking and provide excellent reliability in generator set applications.
- Tough polypropylene cases protect against life-shortening vibration and impact damage.
- Batteries are rated according to SAE standard J-537.
- All batteries are 12-volts. Kits that contain two or four batteries are available for 24-volt systems and/or systems with redundant starters.
- Wet- and dry-charged batteries have lead-calcium or lead-antimony plates and use sulfuric acid electrolyte. Removable cell covers allow checking of electrolyte specific gravity.
- Absorbant glass mat (AGM) batteries are sealed and maintenance free.
- Batteries are for applications below and above 0 ° C (32 ° F).

Charge Type*	Battery Part Number	Battery Qty. per Size	BCI Group Size	Battery SAE Dimension, mm (in.)			Cold Cranking Amps at 18°C (0°F) Min.	Reserve Capacity Minutes at 27° (80°F) Min.	Battery Post Layout and Style
				L	W	H			
Wet	324586	2	31	330.2 (13.0)	173.0 (6.8)	239.8 (9.4)	950	185	C/3

Battery Specifications

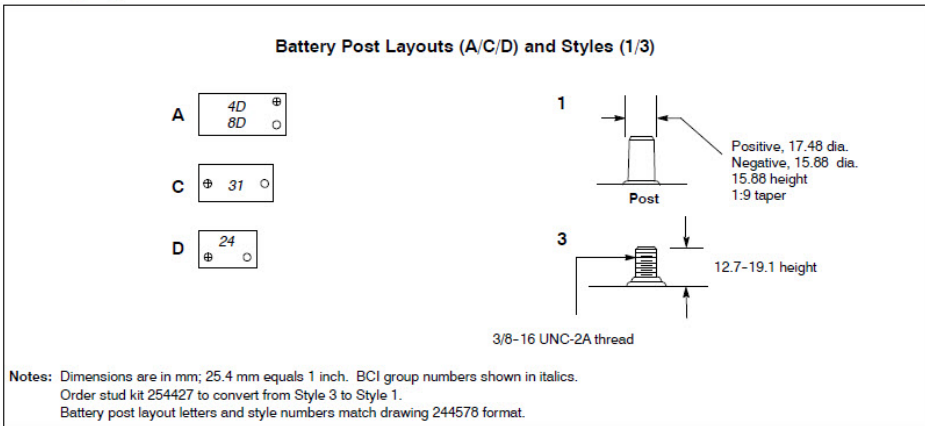

12/24 Volt, 10 Amp

Automatic Multi-Stage Battery Charger

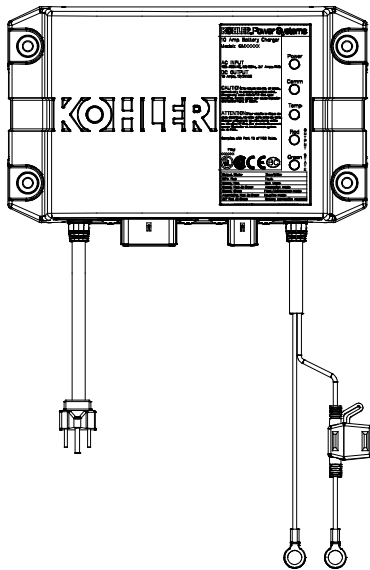

The battery charger is a fully-automatic, high efficiency battery charger that charges batteries rapidly and safely. The battery charger is designed for an industrial environment.

The battery charger is designed for operation with an engine cranking battery.

The battery charger is universal voltage input capable, comes with a standard 120 V/60 Hz AC plug, and charges 12 VDC or 24 VDC battery systems.

Five LED lights indicate power, communication status, temperature compensation status, charge curve, and charger status.

With the optional battery temperature sensor connected, the battery charger can adjust output voltages for optimal charging.

Standard Features

- 12 or 24 VDC output
 - Automatic voltage detection
- Automatic multi-stage charging modes
 - Recovery charge
 - Bulk charge
 - Absorption charge
 - Float charge
 - Equalize charge
- Charges the following type batteries:
 - Flooded lead acid (FLA)
 - AGM
 - Gel cell
 - High performance AGM
 - Nickel-cadmium (NiCad)
- 5 LED status indicators
- Durable potted assembly for waterproofing and vibration resistance
- Reverse-polarity protection
- Short-circuit protection
- Electronically limited output current
- Optional temperature compensation (FLA only)
- User adjustable parameters to support optimal manufacturer recommended charge curve.
- Code compliance:
 - UL 1236 Listed
 - NFPA 110, Level 1 compatible (when used with Kohler controller and connected to engine harness)
 - CSA - C22.2 No. 107.2-01
 - FCC - Title 47, Part 15 Class A
 - CE
 - IBC 2015
 - OSHPD

DC Output		AC Input		Overall Dimensions W x D x H	Shipping Weight	
Volts (Nominal)	Amps	Volts (Nominal)	Amps		kgs	lbs
12/24	10	100-260	3.7	253 mm x 152 mm x 74 mm (10.0 in x 6.0 in x 2.9 in)	3.6	7.9

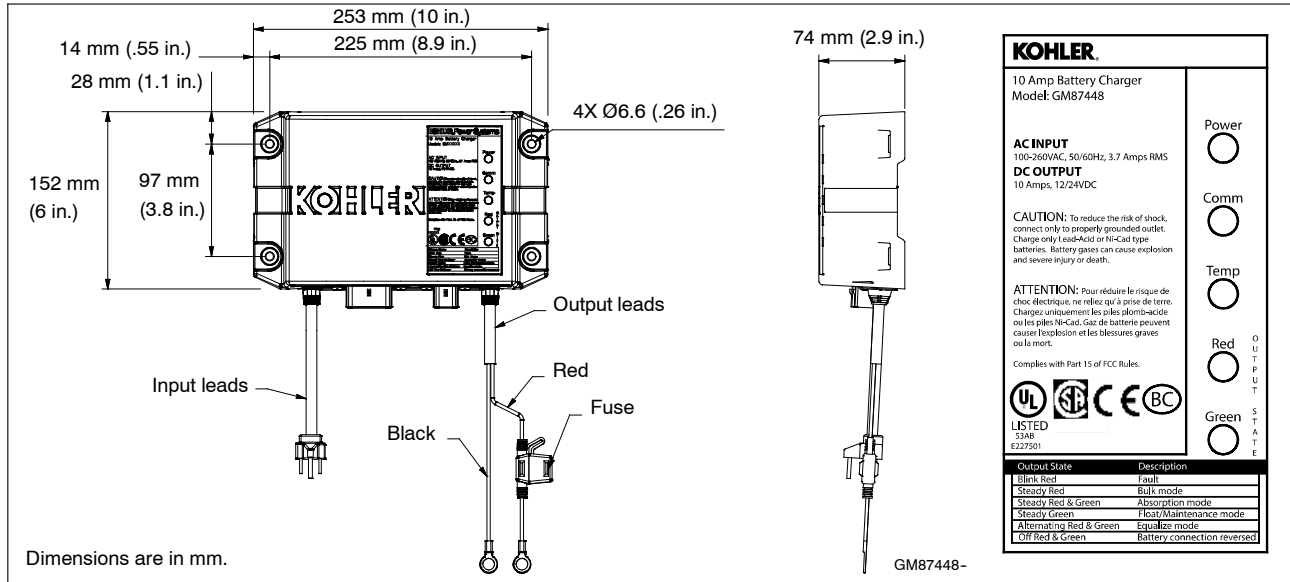

Specifications

AC Input	100-260 VAC
Frequency Input	50/60 Hz
DC Output	10 Amps @ 12 VDC or 10 Amps @ 24 VDC (On battery voltage regulation ±1%; current is electronically limited)
Fuse Protection	15 amps ATC
Battery Types	Flooded Lead Acid (FLA) AGM Gel Cell High Performance AGM Nickel-Cadmium (NiCad)
Monitoring LED Indications	Power Communication Temperature compensation Output charger curve and charger status: <ul style="list-style-type: none"> ○ Red ○ Green
Environmental	
Operating	-20° to 70°C (-4° to 158° F)
Storage	-40° to 85°C (-40° to 185° F)
Relative Humidity	5 to 95% (non-condensing)
Salt Spray Testing	ASTM B117
Corrosion Resistant	From battery gases

Enclosure	
Environmental Resistant	From rain, snow, dust, and dripping water
Battery Connections	
Lead Length	1.8 m (6 ft.) red and black leads
Battery Connections	9.5 mm (3/8 in.) ring terminals
AC Power Connections	
Lead Length	1.8 m (6 ft.)
Storage	Standard US style 3-prong AC plug
Available Options	
Temperature compensation	

DISTRIBUTED BY:

Availability is subject to change without notice. Kohler Co. reserves the right to change the design or specifications without notice and without any obligation or liability whatsoever. Contact your local Kohler® generator distributor for availability.

© 2017, 2019 by Kohler Co. All rights reserved.

Sound Enclosure Standard Features

- Internal-mounted critical silencer and flexible exhaust connector.
- Lift base-mounted or tank mounted steel construction with hinged doors.
- Fade-, scratch-, and corrosion-resistant Kohler® Power Armor automotive-grade textured finish.
- Power Armor surpasses 3,000-hour salt spray corrosion tests per ASTM B- 1117
- Enclosure has four access doors which allow for easy maintenance.
- Lockable, flush-mounted door latches.
- Vertical air inlet and outlet discharge to redirect air and reduce noise.
- Acoustic insulation that meets UL 94 HF1 flammability classification and repels moisture adsorption.
- Sound-attenuated that uses up to 51 mm (2 in.) of acoustic insulation.
- Steel sound enclosure is designed to 150 mph (241 kph) wind load rating.

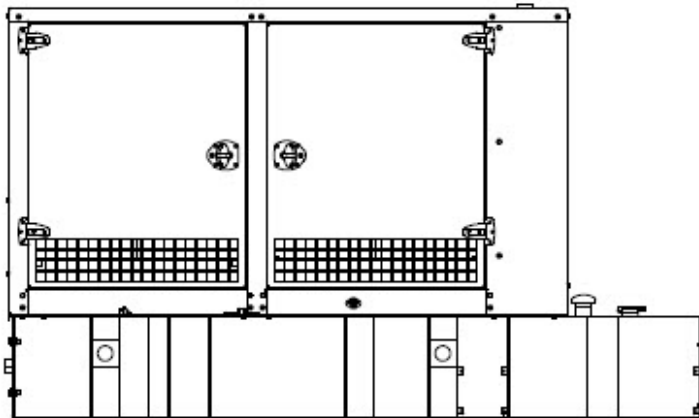

Enclosure with State Code Subbase Fuel Tank

Subbase Fuel Tank Features

- The fuel tank has a Power Armor Plus textured epoxy-based rubberized coating.
- The above-ground rectangular secondary containment tank mounts directly to the generator set, below the generator set skid (subbase).
- Both the inner and outer tanks have emergency relief vents.
- Flexible fuel lines are provided with subbase fuel tank selection.
- The secondary containment generator set base tank meets UL 142 tank requirements. The inner (primary) tank is sealed inside the outer (secondary) tank. The outer tank contains the fuel if the inner tank leaks or ruptures.
- State tanks with varying capacities are an available option. Florida Dept. of Environmental Protection (FDEP) File No. EQ-634 approved.

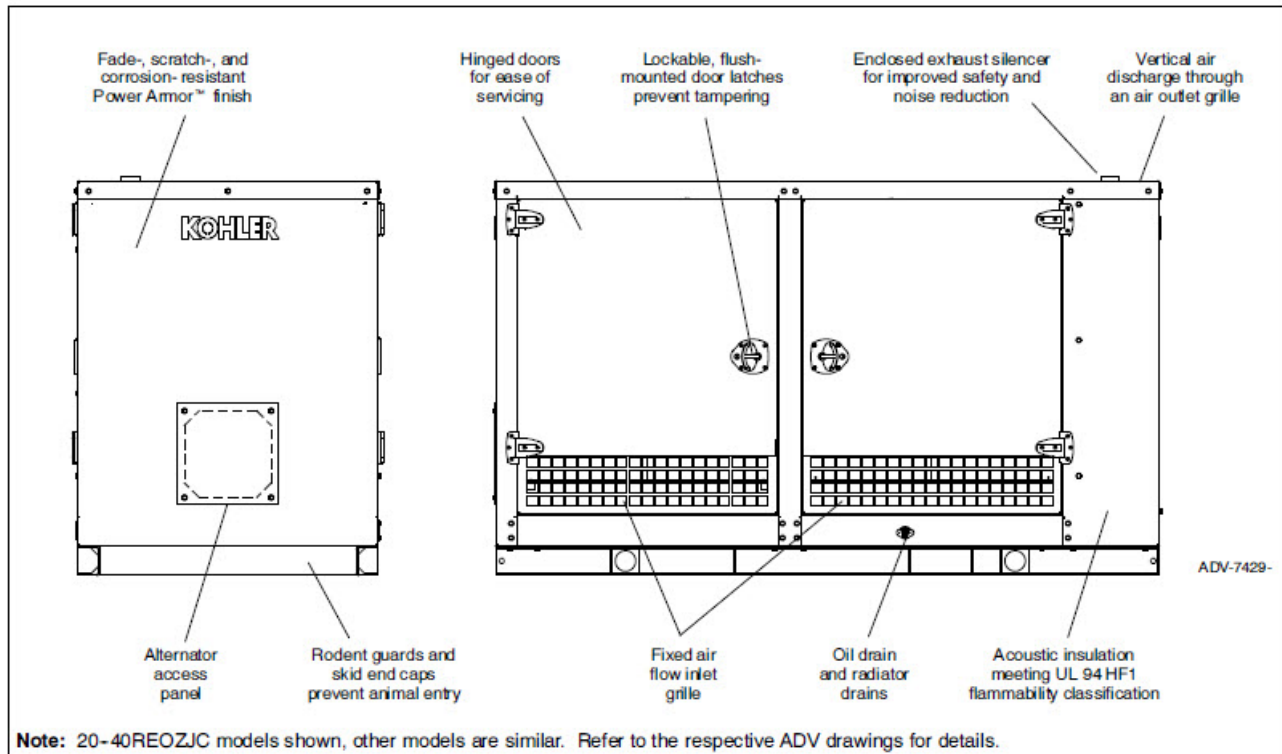

Sound Enclosure Features

- Available in steel (14 gauge) formed panel, solid construction. Preassembled package offering corrosion resistant, dent resilient structure mounting directly to lift base or fuel tank.
- Power Armor automotive-grade finish resulting in advanced corrosion and abrasion protection as well as enhanced edge coverage and color retention.
- Internal exhaust silencer offering maximum component life and operator safety.
- Interchangeable modular panel construction. Allows complete serviceability or replacement without compromising enclosure design.
- Cooling/combustion air intake with a horizontal air inlet. Sized for maximum cooling airflow.
- Service access. Multi-personnel doors for easy access to generator set control and servicing of the fuel fill, fuel gauge, oil fill and battery.
- Cooling air discharge. Weather protective design featuring vertical air discharge. Redirects cooling air up and above the enclosure to reduce ambient noise.
- Attenuated design. Acoustic insulation UL 94 HF1 listed for flame resistance offering up to 51 mm (2 in.) mechanically restrained acoustic insulation.
- Cooling air discharge. The sound enclosures include acoustic insulation with urethane film.
- Note: Installing an additional length of exhaust tail pipe may increase backpressure levels. Please refer to the generator set spec sheet for the maximum backpressure value.

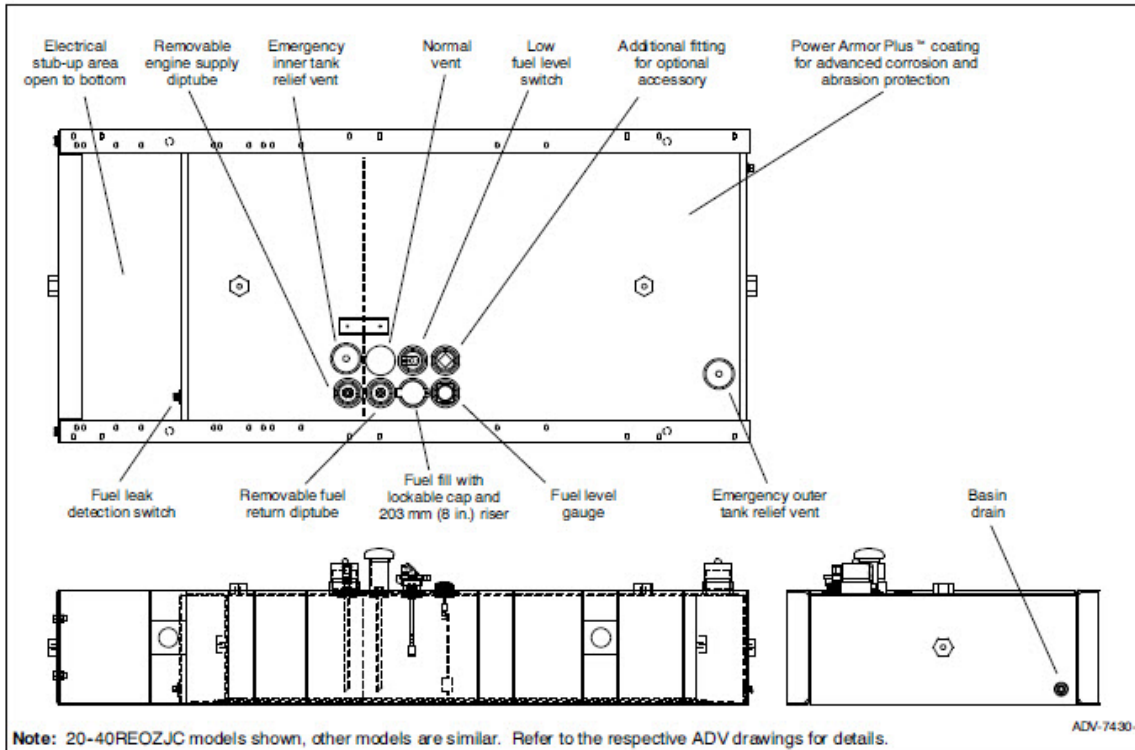

- Extended operation. Usable tank capacity offers full load standby operation of up to 72 hours.
- Power Armor Plus textured epoxy-based rubberized coating that creates an ultra-thick barrier between the tank and harsh environmental conditions like humidity, saltwater, and extreme temperatures, and provides advanced corrosion and abrasion protection.
- UL listed. Secondary containment generator set base tank meeting UL 142 tank requirements.
- NFPA compliant. Designed to comply with the installation standards of NFPA 30 and NFPA 37.
- Integral external lift lugs. Enables crane with spreader-bar lifting of the complete package (empty tank, mounted generator set, and enclosure) to ensure safety.
- Emergency pressure relief vents. Vents ensure adequate venting of inner and outer tank under extreme pressure and/or emergency conditions.
- Normal vent cap. Vent is raised above lockable fuel fill.
- Low fuel level switch. Annunciates a 50% low fuel level condition at generator set control.
- Leak detection switch. Annunciates a contained primary tank fuel leak condition at generator set control.
- Electrical stub-up.
- State tank designed to comply with the installation standards of the Florida Dept. of Environmental Protection (FDEP) File No. EQ-634.

Fuel Tank Capacity, L (gal.)	Est. Fuel Supply Hours at 60 Hz with Full Load	Enclosure and Fuel Tank Length, mm (in.)	Enclosure and Fuel Tank Width, mm (in.)	Enclosure and Fuel Tank Weight, kg (lb.)	Enclosure and Fuel Tank Height, mm (in.)	Fuel Tank Height (H), mm (in.)	Sound Pressure Level, dB(A)
2101 (555)	24/25	5009 (197.2)	1338 (52.7)	4076 (8987)	2894 (113.9)	635 (25)	75

Note: Refer to the respective ADV drawings for details.

Note: Refer to TIB-114 for generator sound data.

Max. weight includes the generator set (wet), enclosure, silencer, and tank (no fuel). The generator set weight represents using the largest alternator option. The enclosure weight is with acoustic insulation added.

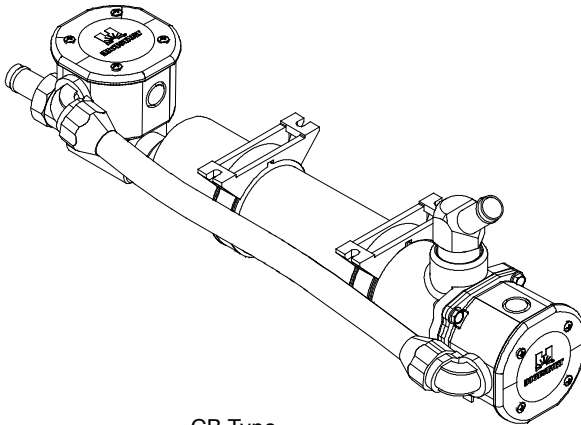
Engine Block Heater Kits

CB Type

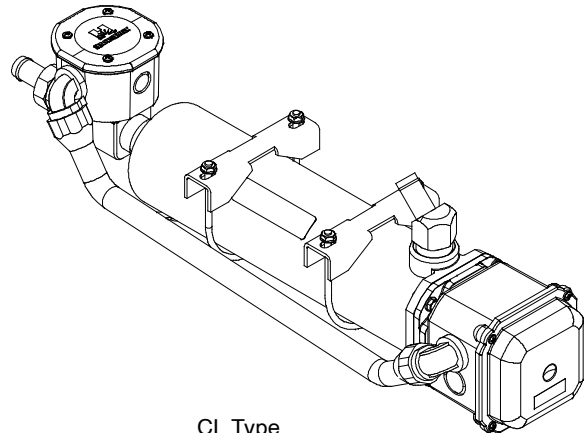

CL Type

Block Heater Kit, Typical

Applicable Models

- 180-200RZXB
- 180-200REZXB
- 230-275REOZJE
- **300-500REOZJ**
- 350-500REOZJB
- 350-500REOZJC
- 350-400REOZJD
- 500REOZVC
- 550-600REOZVB

Standard Features

- UL-C/US listed
- CE compliant
- Controls for automatic operation
- Compact design
- Easy to install

Description

The engine block heater kit heats the engine coolant in cold ambient, warming the cylinders, oil, and charge air circuit which all help to give a faster starting time. The engine block heater uses thermosiphon action to circulate warm coolant into the engine and supplies constant heating to the engine. The engine block heater helps to extend element life and gives a significant reduction in electrical consumption.

The engine block heater has a fixed setting thermostat that turns ON when the engine coolant temperature reaches 27°C (80°F) and turns OFF when the engine coolant temperature reaches 38°C (100°F).

The engine block heater kit is recommended for ambient temperatures below 10°C (50°F).

The engine block heater kits are available in 120 V, 208 V, 240 V, and 480 V versions.

Block Heater Specifications

Heating Fluid	Water, Coolant Mix (50% Glycol/50% Water)
Thermostat Temperature Range	27° - 38°C (80° - 100°F)
Temperature High Limit	96°C (205°F)
Max. Pressure	125 psi (860 kPa)
Inlet/Outlet Plumbing	1 in. NPT
System Ingress	NEMA 4

Specifications

Block Heater Kit Number	Component	Watts	Voltage	Phase
GM75809- KA1	GM76113	2500	90- 120	1
GM75809- KA2	GM76114	2500	190- 208	1
GM75809- KA3	GM76115	2500	210- 240	1
GM75809- KA4	GM76116	2500	380- 480	1
GM76120- KA1	GM76113	2500	90- 120	1
GM76120- KA2	GM76114	2500	190- 208	1
GM76120- KA3	GM76115	2500	210- 240	1
GM76120- KA4	GM76116	2500	380- 480	1
GM79186- KA1	GM79182	4000	190- 208	1
GM79186- KA2	GM79183	4000	210- 240	1
GM79186- KA3	GM79184	4000	380- 480	1
GM79186- KP1	GM79182	4000	190- 208	1
GM79186- KP2	GM79183	4000	210- 240	1
GM79186- KP3	GM79184	4000	380- 480	1
GM79187- KA1	GM79182	4000	190- 208	1
GM79187- KA2	GM79183	4000	210- 240	1
GM79187- KA3	GM79184	4000	380- 480	1
GM79187- KP1	GM79182	4000	190- 208	1
GM79187- KP2	GM79183	4000	210- 240	1
GM79187- KP3	GM79184	4000	380- 480	1
GM84820- KA1	GM76113	2500	90- 120	1
GM84820- KA2	GM76114	2500	190- 208	1
GM84820- KA3	GM76115	2500	210- 240	1
GM84820- KA4	GM76116	2500	380- 480	1

Wiring Diagram

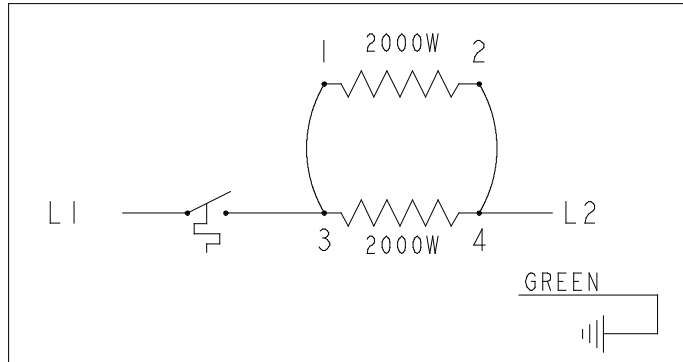

208 VAC single phase- parallel

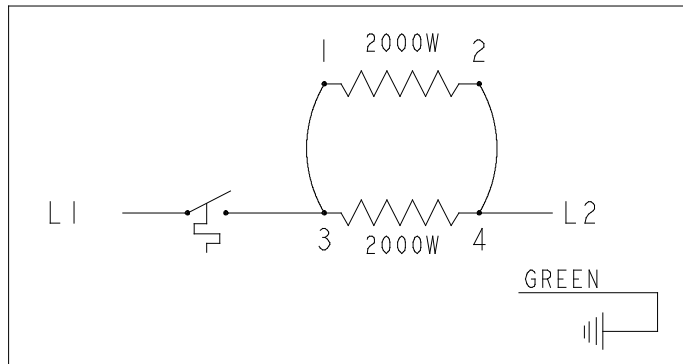

240 VAC single phase- parallel

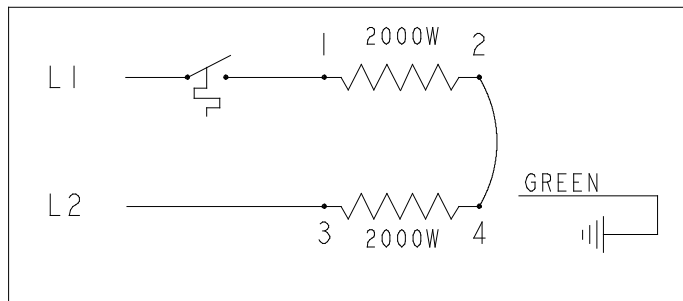

480 VAC single phase- parallel

Dimensions and Weights

CB type block heater size, L x H x W, mm (in):	510 x 132 x 129 (20.1 x 5.2 x 5.1)
CL type block heater size, L x H x W, mm (in):	597 x 147 x 158 (23.5 x 5.8 x 6.2)
CB type block heater weight, kg (lb):	3 (6.9)
CL type block heater weight, kg (lb):	4.5 (10)

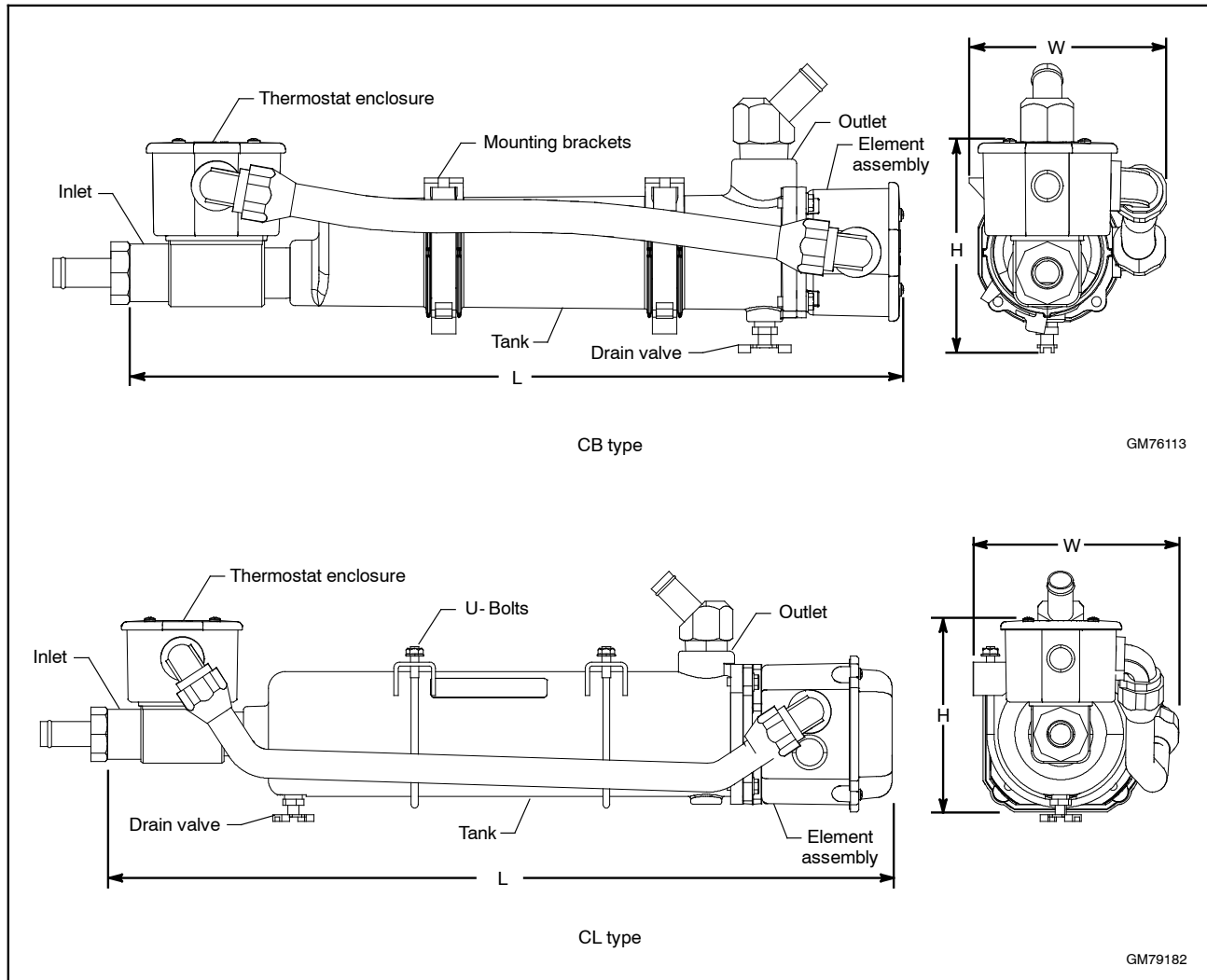

DISTRIBUTED BY:

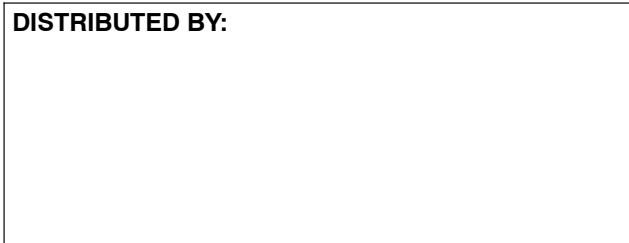

Availability is subject to change without notice. Kohler Co. reserves the right to change the design or specifications without notice and without any obligation or liability whatsoever. Contact your local Kohler® generator distributor for availability.

© 2020 Kohler Co. All rights reserved.



**Integral Voltage Regulator with Kohler® APM603
Controllers and Menu-Driven Selections (80-4000 kW
Generator Set Models)**

Voltage Regulators

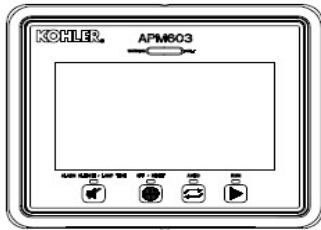

**APM603 Controller
with Integral Voltage Regulator**

The following information provides general features, specifications, and functions of available voltage regulators.

This information generally applies to a single generator set and multiple generator sets with paralleling applications. Refer to the respective generator set specification sheet and see your authorized distributor for information regarding specific voltage regulator applications and availability.

The voltage regulator is integral to the controller and uses patented high speed digital voltage regulator design providing $\pm 0.25\%$ no-load to full-load regulation using root-mean-square (RMS) voltage sensing.

Integral Voltage Regulators with APM603

Calibration	Range Settings	Default Selection
Voltage Adjustment	$\pm 10\%$ of System Voltage	System Voltage
Controller Gain	40 to 70 Hz	P: 1.3 I: 1.0 D: 0.25
Underfrequency Unload or Frequency Setpoint	40 to 70 Hz	0.5 Hz Below System Frequency (ECM)
Underfrequency Unload Scope	0-10% of System Voltage (Volts per Cycle)	15 volts per Cycle at 480 Volts (3.1%)
Reactive Droop	0-10% of System Voltage	4% of System Voltage
VAR Control	-50% to 110%	0 kVAR
PF Adjust Control	-0.50 to 1.0 to 0.50	0.8 Lagging
VAR/PF Gain Adjustment	P: 0.3 to 3.00 I: 0.3 to 3.00 D: 0.3 to 3.00	P: 1.0 I: 1.0 D: 0.25



Specification/Feature	Integral with APM603
Generator Set Availability	80-4000 kW
Type	Patented Hybrid Design
Status and Shutdown Indicators	LEDs and Text LCD Display
Operating Temperature	-40 ° C to 70 ° C (-40 ° F to 158 ° F)
Storage Temperature	-40 ° C to 85 ° C (-40 ° F to 185 ° F)
Humidity	5-95% Non-Condensing
Circuit Protection	Solid-State, Redundant Software and Fuses
Sensing, Nominal	100-600 Volts (L-L), 50-60 Hz
Sensing Mode	RMS, Single- or 3-Phase
Input Requirements	8-36 VDC
Continuous Output	5.0 ADC with GM88453 Activator Board
Maximum Output	7.8 ADC with GM88453 Activator Board
Transition Frequency	50-70 Hz
Exciter Field Resistance	4-30 Ohms with GM88453 Activator Board
No-Load to Full-Load Voltage Regulation	± 0.25%
Thermal Drift	<0.5% (-40 ° C to 70 ° C) [-40 ° F to 158 ° F] Range
Response Time	3-phase: 1 mS 1-phase: 5 mS
System Voltage Adjust.	± 10%
Voltage Adjustment	Controller Display
Remote Voltage Adjustment	Analog 0-5 VDC (± 10%) Input Optional
Paralleling Capability	Full Load Share and Control plus Reactive Droop

Integral Voltage Regulator with APM603 Controller

- A 7.5-inch color TFT touchscreen provides access to data.
- The controller provides an interface between the generator set and switchgear for paralleling applications incorporating multiple generator set and/or utility feeds.
- The controller can control Fast Response™ II, Fast Responset™X, and PMG alternators using the GM88453 activator board.

Voltage Regulator Settings, APM603 Controller

- Voltage Regulator Configuration
 - Under Frequency Unload Settings
 - Single and Three Phase Sensing
 - Voltage Target
 - Voltage Regulator Gains

Paralleling Settings, APM603

- Synchronizing parameters setup
 - Voltage matching
 - Frequency matching
 - Phase matching
 - Time delay
- Load sharing
 - kW sharing
 - kVAR sharing
 - Baseload settings
 - Droop

Paralleling Metering, APM603

- Paralleling State
- Paralleling Mode
- System Voltage
- System Frequency
- Connected Generators
- Sync Status
- Engine Speed

VAR/PF Control Input	VAR Control Mode, PF Control Mode, System VAR Control, System PF Control
----------------------	--

Activator Board GM88453

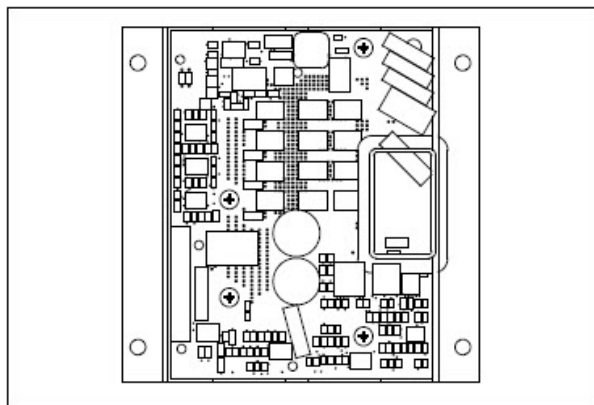

- Interfaces between the controller and alternator assembly using rotor field leads, auxiliary power windings, and optic board leads.
- Allows the Decision-Maker® controllers the ability to control a wound-field alternator using the same control signal as Fast Response
- Permits the generator set controller to control the current to the exciter field of a wound-field excited alternator.
- Contains two isolated relay driver outputs (RDO) rated at 250 mA. Provides RDO outputs indicating a field over-excitation condition and that the alternator is supplying voltage to the activator.

Modbus® is a registered trademark of Schneider Electric.

Remote Serial Annunciator III (RSA III)

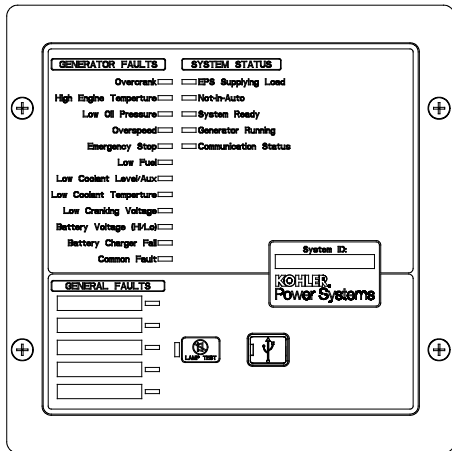

RSA III

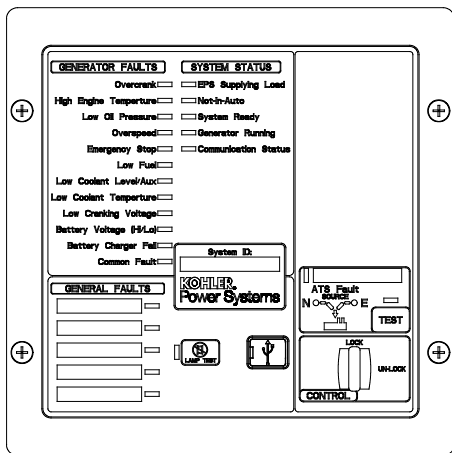

RSA III with a Single ATS Control

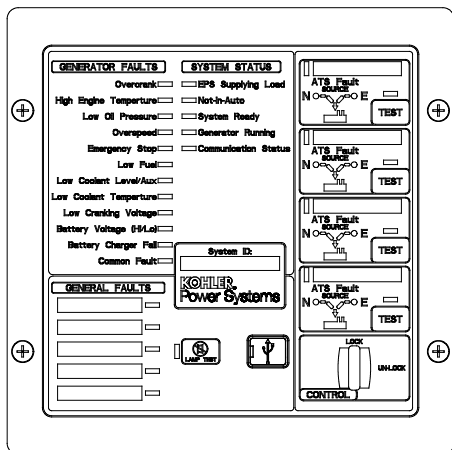

RSA III with Four ATS Controls

Remote Serial Annunciator III (RSA III) for Kohler® Controllers

- Monitors the generator set equipped with one of the following controllers:

APM402	Decision-Maker® 3000
APM603	Decision-Maker® 3500
APM802	Decision-Maker® 6000
Decision-Maker® 3+	Decision-Maker® 8000
Decision-Maker® 550	KPC 1000
- Allows monitoring of the common alarm, remote testing of the automatic transfer switch, and monitoring of the normal/emergency source for up to four ATS with any of the following controllers:

Decision-Maker®	MPAC® 750, 1200, and 1500
MPAC®	1000 and 1500
- Configuration via a personal computer (PC) software.
- Writable surfaces (white boxes in illustrations) for user-defined selections.
- Uses Modbus® RTU protocol.
- Controller connections:
 - RS-485 for serial bus network
 - USB port. Connect a personal computer and use Kohler® SiteTech™ software to view events and adjust settings. *
 - 12-/24-volt DC power supply
 - 120/208 VAC power supply (available accessory)
- Meets the National Fire Protection Association Standard NFPA 110, Level 1.

Dimensions

- Dimensions—W x H x D, mm (in.).

Surface Mounted:

203 x 203 x 83 (8.0 x 8.0 x 3.3)

Flush Mounted (Inside Wall):

203 x 203 x 76 (8.0 x 8.0 x 3.0)

Flush mounting plate W1: 254 (10.0)

* SiteTech™ software is available to Kohler authorized distributors and dealers.

Modbus® is a registered trademark of Schneider Electric.

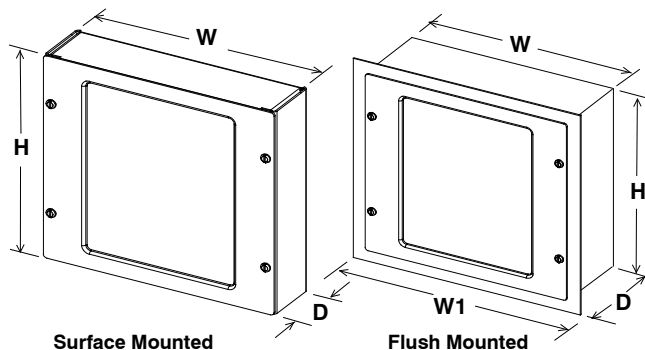

Fault and Status Conditions	Fault LEDs	Fault Horn	System Ready LED	Generator Running LED	Communication Status LED
Overcrank Shutdown	Red	On	Red	Off	Green
High Engine Temperature Warning *	Yellow	On	Red	Green	Green
High Engine Temperature Shutdown	Red	On	Red	Off	Green
Low Oil Pressure Warning *	Yellow	On	Red	Green	Green
Low Oil Pressure Shutdown	Red	On	Red	Off	Green
Overspeed Shutdown	Red	On	Red	Off	Green
Emergency Stop *	Red	On	Red	Off	Green
Low Coolant Level/Aux. Shutdown	Red	On	Red	Off	Green
Low Coolant Temperature *	Yellow	On	Red	Off	Green
Low Cranking Voltage	Yellow	On	Red	Off	Green
Low Fuel—Level or Pressure *	Yellow	On	Red	Green or Off	Green
Not-In-Auto	Red	On	Red	Green or Off	Green
Common Fault	Red	On	Green	Green or Off	Green
Battery Charger Fault (1) *	Yellow	On	Red	Green or Off	Green
Battery Charger Fault (2) *	Yellow	On	Green	Green or Off	Green
High Battery Voltage *	Yellow	Off	Green	Green or Off	Green
Low Battery Voltage *	Yellow	Off	Green	Green or Off	Green
User Input #1 (Warning)	Yellow	Off	Green	Green or Off	Green
User Input #1 (Shutdown)	Red	On	Green	Off	Green
User Input #2 (Warning)	Yellow	Off	Green	Green or Off	Green
User Input #2 (Shutdown)	Red	On	Green	Off	Green
User Input #3 (Warning) (1) †	Yellow	Off	Green	Green or Off	Green
User Input #3 (Shutdown) (1) †	Red	On	Green	Off	Green
User Input #4 (Warning) (1)	Yellow	Off	Green	Green or Off	Green
User Input #4 (Shutdown) (1)	Red	On	Green	Off	Green
User Input #5 (Warning) (1)	Yellow	Off	Green	Green or Off	Green
User Input #5 (Shutdown) (1)	Red	On	Green	Off	Green
EPS Supplying Load	Yellow	Off	Green	Green	Green
Communications Status (Fault mode)	—	Off	Green or Red	Green or Off	Red
ATS Fault (RSA III with ATS Controls only)	Red	On	Red or Yellow	Green or Off	Green

Green LEDs appear as steady on when activated.

Yellow LEDs slow flash when activated except steady on with EPS supplying load and high battery voltage.

Red LEDs slow flash when activated except fast flash with loss of communication and not-in-auto.

Specifications

- LED indicating lights for status, warning, and/or shutdown.
- Power source with circuit protection: 12- or 24-volt DC
- Power source with 120/208 VAC, 50/60 Hz adapter (option)
- Power draw: 200 mA
- Humidity range: 0% to 95% noncondensing
- Operating temperature range: -20°C to +70°C (-4°F to +158°F)
- Storage temperature range: -40°C to +85°C (-40°F to +185°F)
- Standards:
 - NFPA 110, level 1
 - UL 508 recognized
 - CE directive
 - NFPA 99
 - ENS 61000-4-4
 - EN611-4-4 fast transient immunity
- RS-485 Modbus® isolated port @ 9.6/19.2/38.4/57.6 kbps (default is 19.2 kbps)
- USB device port
- NEMA 1 enclosure

(1) All generator set controllers except Decision-Maker® 3+ controller.

(2) Decision-Maker® 3+ controller only.

* May require optional kit or user-provided device to enable function and LED indication.

† Digital input #3 is factory-set for high battery voltage on the Decision-Maker® 3+ controller.

Modbus® is a registered trademark of Schneider Electric.

NFPA Requirements

- NFPA 110 compliant
- Engine functions:
 - High battery voltage warning *
 - High engine temperature shutdown
 - High engine temperature warning *
 - Low battery voltage warning *
 - Low coolant level/aux. shutdown
 - Low coolant temperature warning *
 - Low cranking voltage
 - Low fuel warning (level or pressure) *
 - Low oil pressure shutdown
 - Low oil pressure warning *
 - Overcrank shutdown
 - Overspeed shutdown
- General functions:
 - Audible alarm silence
 - Battery charger fault *
 - Lamp test
 - Master switch not-in-auto

Fault and Status LEDs and Lamp Test Switch

Alarm Horn. Horn sounds giving a minimum 90 dB at 0.1 m (0.3 ft.) audible alarm when a warning or shutdown fault condition exists except on high/low battery voltage or EPS supplying load.

Alarm Silenced. Red LED on lamp test switch lights when alarm horn is deactivated by alarm silence switch.

Alarm Silence Switch. Lamp test switch quiets the alarm during servicing. The horn will reactivate upon additional faults.

ATS Fault. Red LED lights when ATS fails to transfer.

Battery Charger Fail. LED lights if battery charger malfunctions. Requires battery charger with alarm contact.

Battery Voltage Hi/Lo. LED flashes if battery or charging voltage drops below preset level. LED lights steady if battery voltage exceeds preset level.

Common Fault. LED lights when a single or multiple common faults occur.

Communication Status. Green LED lights indicating annunciator communications functional. Red LED indicates communication fault.

EPS Supplying Load. LED lights when the Emergency Power System (EPS) generator set is supplying the load (APM402, APM603, APM802, and Decision-Maker® 550, 3000, 3500, 6000, and 8000 controllers) or when transfer switch is in the emergency position (Decision-Maker® 3+ controller).

Emergency Stop. LED lights and engine stops when emergency stop is made. May require a local emergency stop switch on some Decision-Maker® 3+ controllers.

Generator Running. LED lights when generator set is in operation.

High Engine Temperature. Red LED lights if engine has shut down because of high engine coolant temperature. Yellow LED lights if engine coolant temperature approaches shutdown range. Requires warning sender on some models.

Lamp Test (Switch). Switch tests all the annunciator indicator LEDs and horn.

Low Coolant Level/Aux. LED lights when engine coolant level is below acceptable range on radiator-mounted generator sets only. When used with a Decision-Maker® 3+ controller, the LED indicates low coolant level or an auxiliary fault shutdown. Requires user-supplied low coolant level switch on remote radiator models.

Low Coolant Temperature. LED lights if optional engine block heater malfunctions and/or engine coolant temperature is too low. Requires prealarm sender on some models.

Low Cranking Voltage. LED lights if battery voltage drops below preset level during engine cranking.

Low Fuel (Level or Pressure). LED lights if fuel level in tank approaches empty with diesel models or fuel pressure is low on gas models. Requires customer-supplied switch.

Low Oil Pressure. Red LED lights if generator set shuts down because of insufficient oil pressure. Yellow LED lights if engine oil pressure approaches shutdown range. Requires warning sender on some models.

Not In Auto. LED lights when the generator set controller is not set to automatic mode.

Overcrank. LED lights and cranking stops if engine does not start in either continuous cranking or cyclic cranking modes.

Overspeed. LED lights if generator set shuts down because of overspeed condition.

System Ready. Green LED lights when generator set master switch is in AUTO position and the system senses no faults. Red LED indicates system fault.

User-Defined Digital Inputs #1-#5. Monitors five digital auxiliary inputs (can be configured as warnings or shutdowns). User-defined digital inputs are selected via the RSA III master for local or remote (generator set or ATS). The user-defined digital input can be assigned via PC using SiteTech™ setup software.

KOHLER®

Alternator Data

TECHNICAL INFORMATION BULLETIN

Alternator Data Sheet

Alternator Model: 4UA13
Frequency: 60 Hz
Speed: 1800 RPM
Leads: 12 (6 Lead, 600 Volt)

Voltage L-N/L-L	Phase	Power Factor	Connection	kW* (kVA)						
				Class B	Class F				Class H	
				80°C Continuous	90°C Lloyds	95°C ABS	105°C Continuous	130°C Standby	125°C Continuous	150°C Standby
139/240 277/480	3	0.8	Wye	275.0 (343.8)	285.0 (356.3)	290.0 (362.5)	300.0 (375.0)	300.0 (375.0)	300.0 (375.0)	300.0 (375.0)
127/220 254/440	3	0.8	Wye	272.0 (340.0)	283.0 (353.8)	288.5 (360.6)	300.0 (375.0)	300.0 (375.0)	300.0 (375.0)	300.0 (375.0)
120/208 240/416	3	0.8	Wye	272.0 (340.0)	283.0 (353.8)	288.5 (360.6)	300.0 (375.0)	300.0 (375.0)	300.0 (375.0)	300.0 (375.0)
110/190 220/380	3	0.8	Wye	245.0 (306.3)	259.0 (323.8)	266.0 (332.5)	280.0 (350.0)	280.0 (350.0)	280.0 (350.0)	280.0 (350.0)
120/240	3	0.8	Delta	264.0 (330.0)	278.0 (347.5)	285.5 (356.9)	300.0 (375.0)	300.0 (375.0)	300.0 (375.0)	300.0 (375.0)
120/240	1	1.0	Dogleg	190.0 (190.0)	198.0 (198.0)	202.0 (202.0)	210.0 (210.0)	230.0 (230.0)	226.0 (226.0)	230.0 (230.0)
120/240	1	0.8	Dogleg	140.0 (175.0)	146.0 (182.0)	150.0 (188.0)	156.0 (195.0)	185.0 (231.3)	169.0 (211.0)	185.0 (231.3)
347/600	3	0.8	Wye	275.0 (343.8)	285.0 (356.3)	290.0 (362.5)	300.0 (375.0)	300.0 (375.0)	300.0 (375.0)	300.0 (375.0)

* All data tested in accordance with IEEE Standard 115. Kohler Co. reserves the right to change the design or specifications without notice and without any obligation or liability whatsoever.

Submittal Data: 139/240 Volts, 0.8 PF, 1800 RPM, 60 Hz, 3-Phase, 130°C Rise

	Symbol	Per Unit	Ohms		Symbol	Value
Typical Resistances				Typical Time Constants		
Phase Resistance		0.020	0.003	Armature Short Circuit	T _a	0.018 sec.
Rotor Resistance		13.854	2.128	Transient Short Circuit	T' _d	0.185 sec.
Typical Reactances				Transient Open Circuit	T' _{do}	2.184 sec.
Synchronous				Typical Field Current		
Direct	X _d	3.417	0.525	Full Load	I _{fFL}	29.57 amps
Quadrature	X _q	1.178	0.273	No Load	I _{fNL}	8.3 amps
Transient				Typical Short Circuit Ratio		0.391
Unsaturated	X' _{du}	0.328	0.050	Harmonic Distortion		
Saturated	X' _d	0.289	0.044	RMS Total Harmonic Distortion		2.7%
Subtransient				Max. Single Harmonic		7 th
Direct	X'' _d	0.133	0.020	Deviation Factor (No Load, L-L)		4.3%
Quadrature	X'' _q	0.139	0.021	Telephone Influence Factor		<50
Negative Sequence	X ₂	0.136	0.021	Insulation Material Class		
Zero Sequence	X ₀	0.011	0.002	per NEMA MG1-1.66		H
				Phase Rotation		ABC

**4UA13, 60 Hz, 139/240, 277/480 Volts, Wye
TYPICAL ALTERNATOR EFFICIENCY***

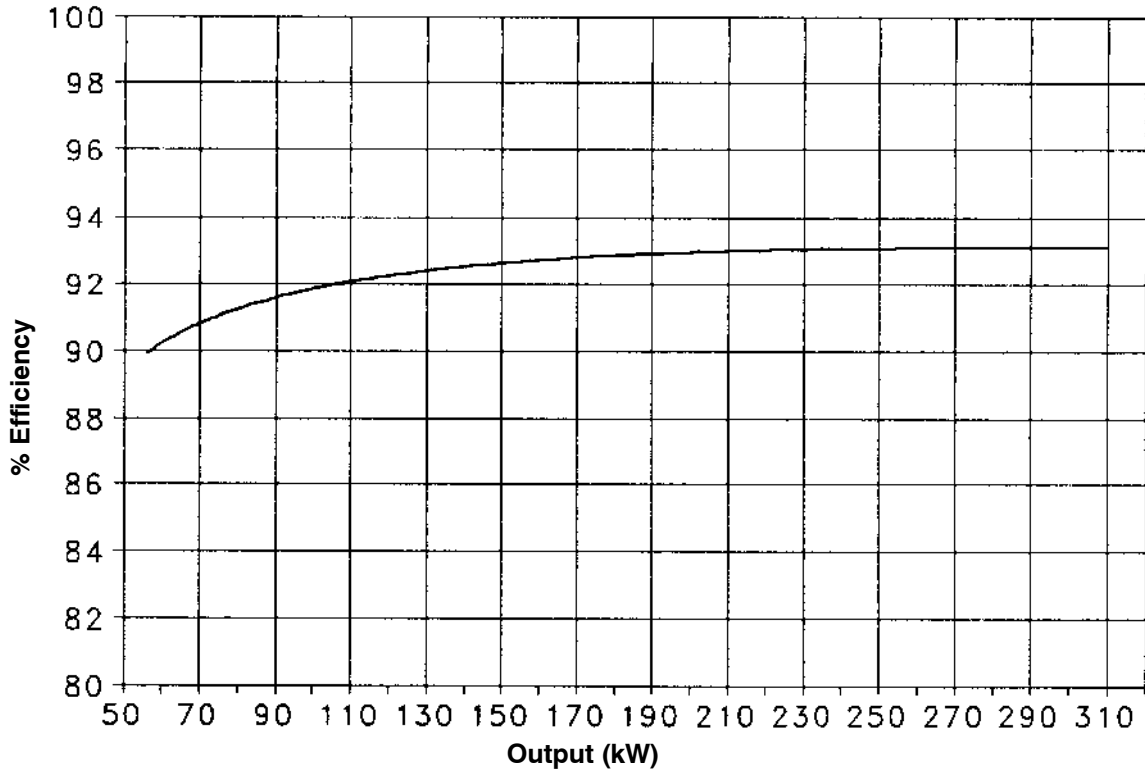

**4UA13, 60 Hz, 139/240, 277/480 Volts, Wye
TYPICAL MOTOR STARTING CHARACTERISTICS***

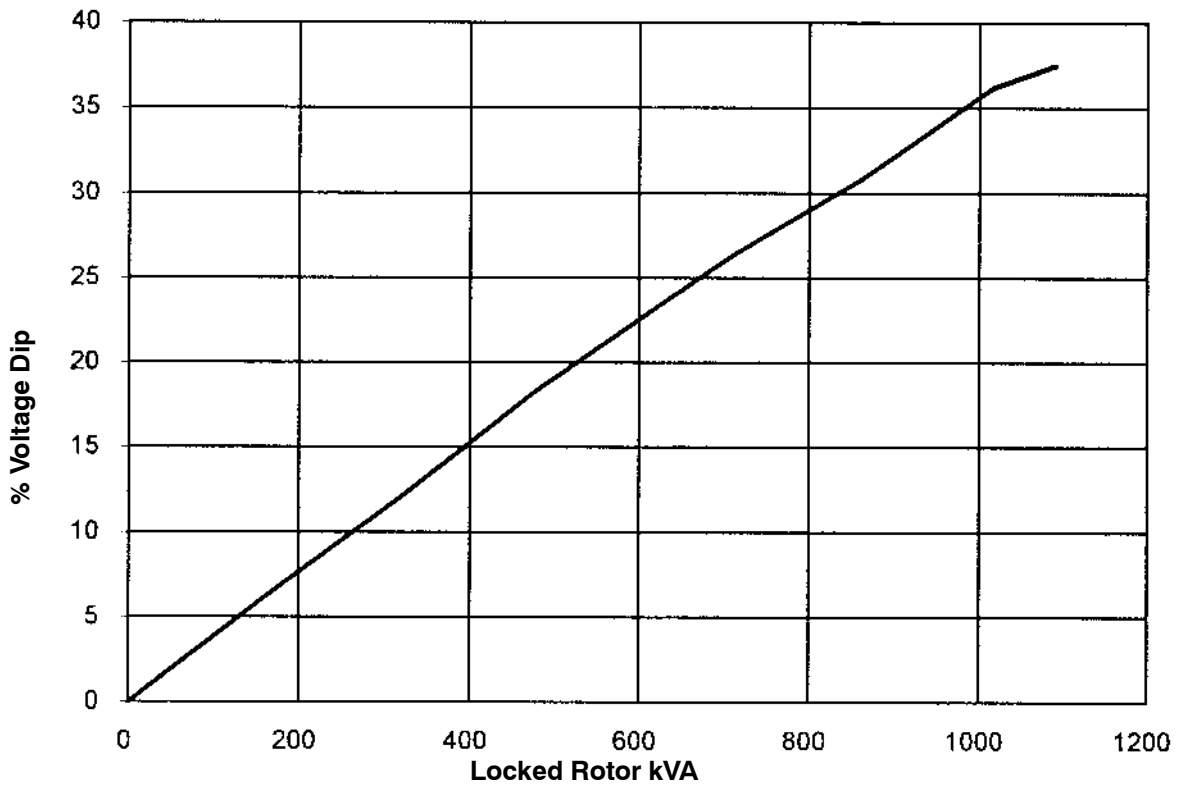

* All data tested in accordance with IEEE Standard 115. Kohler Co. reserves the right to change the design or specifications without notice and without any obligation or liability whatsoever.

**4UA13, 60 Hz, Low Wye or Delta Connection
SHORT CIRCUIT DECREMENT CURVE**

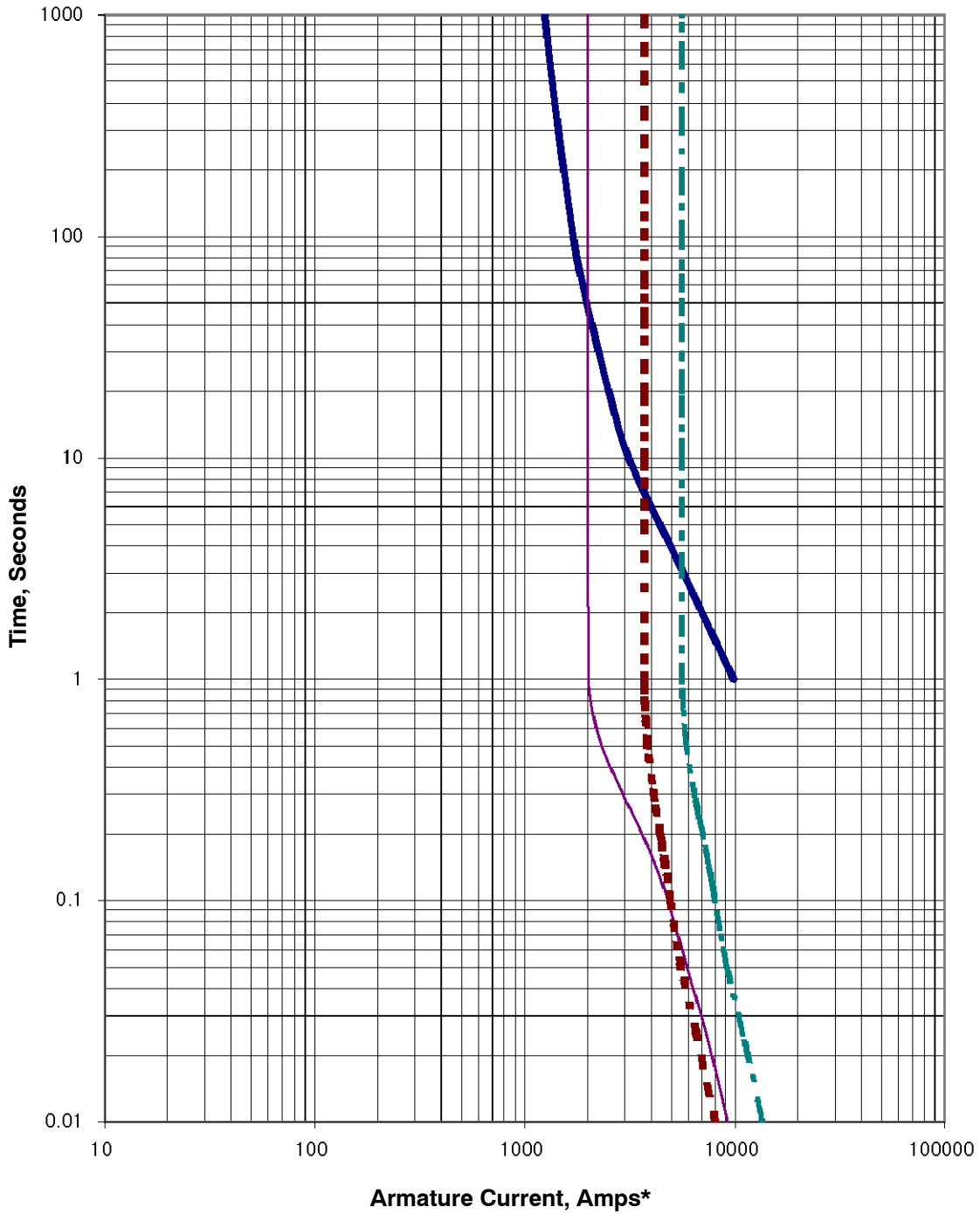

- Alternator Damage Curve
- 3 Phase Symmetrical
- Line-to-Line 1 Phase
- Line-to-Neutral 1 Phase

* Instantaneous current (t=0) is asymmetric. Divide by 1.732 for symmetric.

**4UA13, 60 Hz, High Wye Connection
SHORT CIRCUIT DECREMENT CURVE**

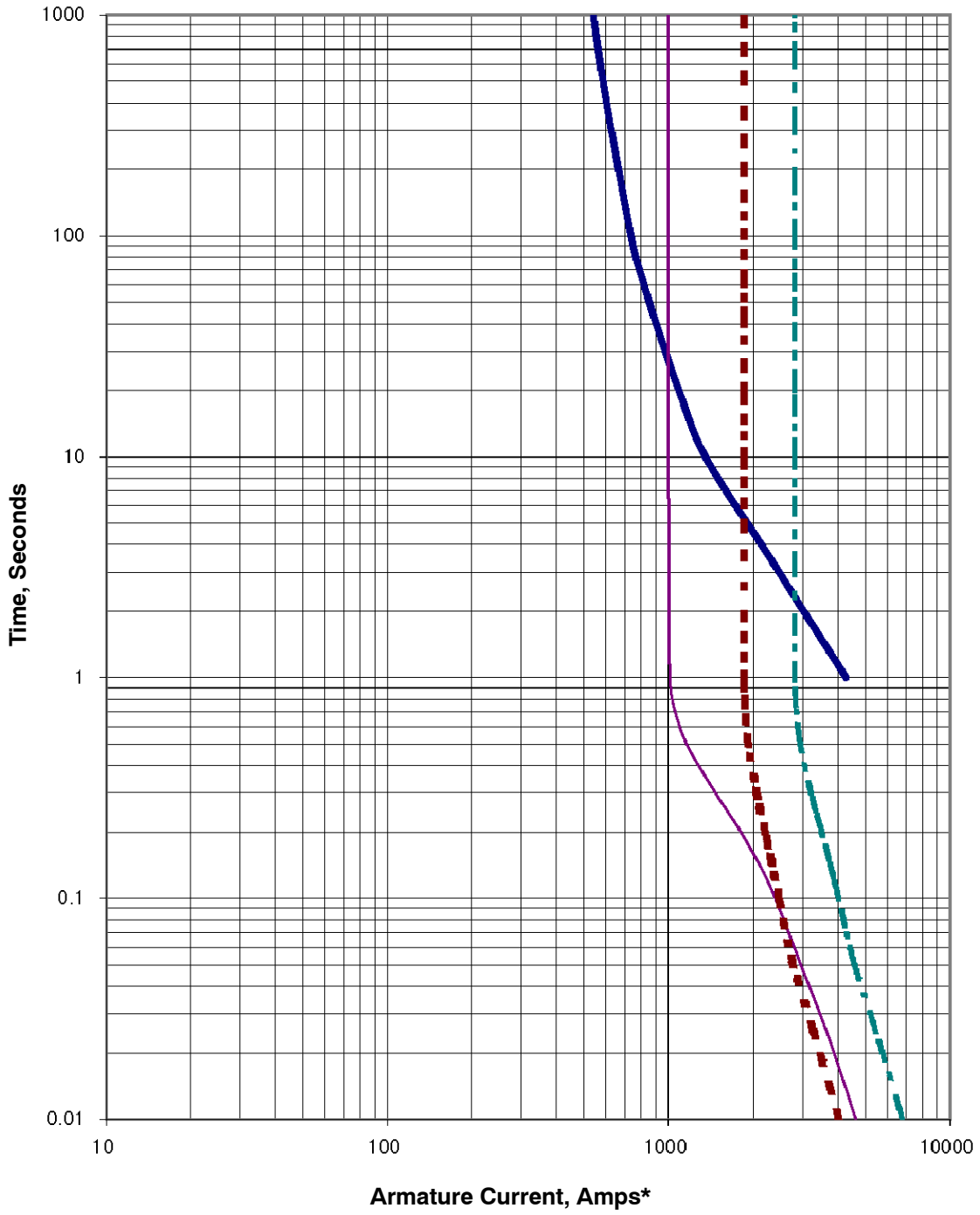

- Alternator Damage Curve
- 3 Phase Symmetrical
- Line-to-Line 1 Phase
- Line-to-Neutral 1 Phase

* Instantaneous current (t=0) is asymmetric. Divide by 1.732 for symmetric.

**4UA13, 60 Hz, 600 V Connection
SHORT CIRCUIT DECREMENT CURVE**

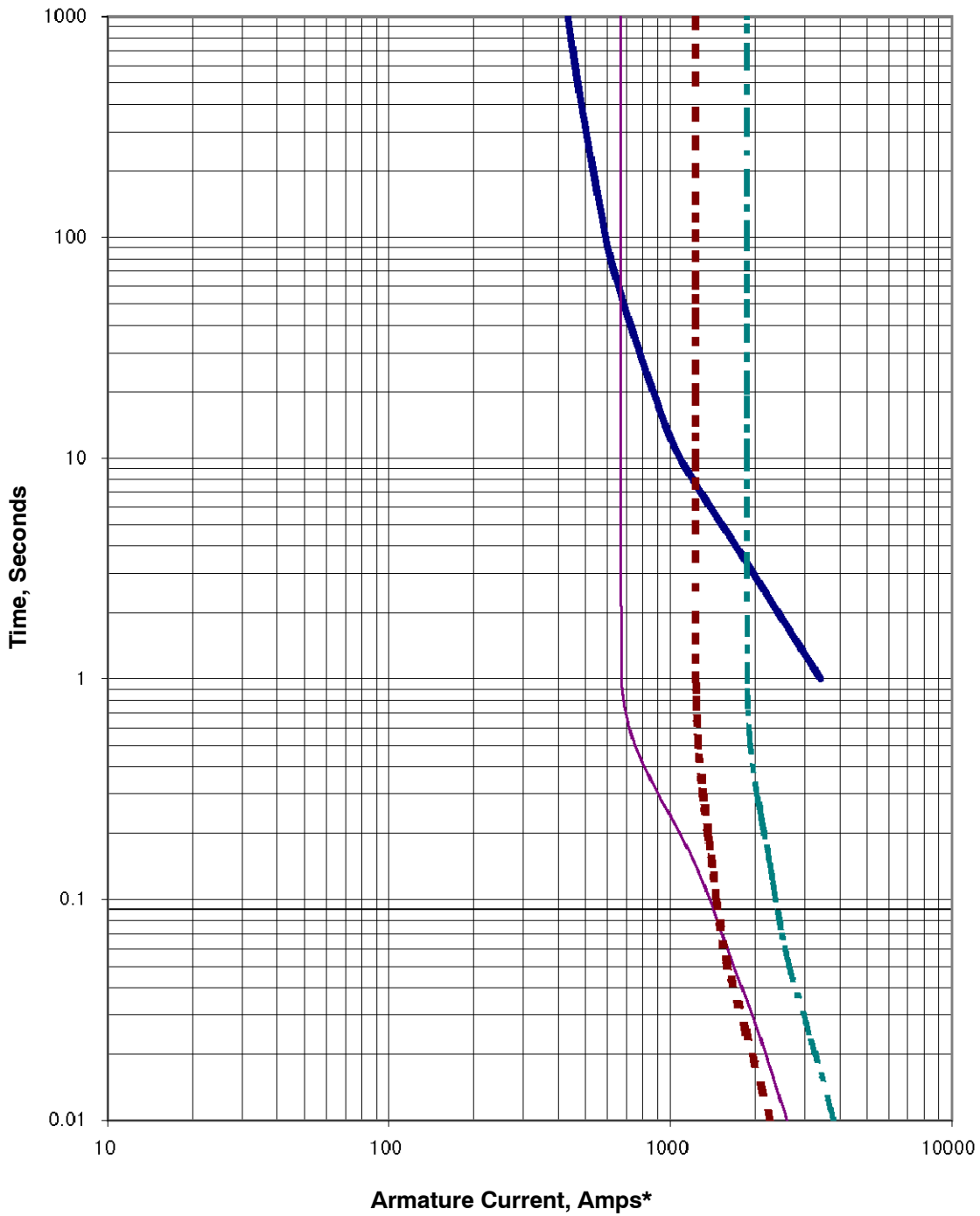

- Alternator Damage Curve
- 3 Phase Symmetrical
- Line-to-Line 1 Phase
- Line-to-Neutral 1 Phase

* Instantaneous current (t=0) is asymmetric. Divide by 1.732 for symmetric.

KOHLER®

Cooling Data

TECHNICAL INFORMATION BULLETIN

Generator Set Cooling System Data Sheet

300REOZJ 60Hz (Standby Duty)	50°C Ambient Temperature Cooling System								
	Total external restriction on open unit⁷	Pa <i>(in. H₂O)</i>	0 (0)	125 (0.5)	187 (0.75)	250 (1)	312 (1.25)	375 (1.5)	Enclosed Units
	Maximum allowable ambient temperature	°C <i>(°F)</i>	51 (124)	48 (118)	46 (115)	45 (113)	44 (111)	NA (NA)	45 (113)
	Cooling system airflow	m ³ /min <i>(ft³/min)</i>	396 (14000)	372 (13100)	360 (12700)	347 (12300)	335 (11800)	NA (NA)	NA (NA)

1. The data shown above is the anticipated cooling performance for a typical generator set when following proper installation techniques.
2. Cooling performance is based on operation at 100 m (328 ft.) above sea level. For elevations higher than 100 m (328 ft.), typical cooling performance derate is 1°C (1.8°F) per 250 m (820 ft.).
3. For high ambient conditions, check TIB-101 for the generator set power output derate schedule.
4. Incorrect installation, improper operation, fouling of the cooling system, and other variable conditions may reduce cooling performance.
5. Kohler manufactured sound enclosed models are rated in free air with no additional restriction. Consult factory for other variants or conditions such as additional ducting or hoods.
6. Performance is based on a 50/50 water and ethylene glycol mixture.
7. Total external restriction includes restriction upstream and downstream of the unit – any ducting supplying intake air to the unit and any ducting for the discharge.

KOHLER®

Sound Data

TECHNICAL INFORMATION BULLETIN

Generator Set Sound Data Sheet

			Sound Pressure Data in dB(A)			
Generator Set Model	Hz	Load	Raw Exhaust	Open Unit, Isolated Exhaust	Weather Enclosure	Sound Enclosure
300REOZJ	60	100% Load	119.1	91.4	89.5	75.8
		No Load	99.6	84.9	83.0	70.9

Note: Sound pressure data is the logarithmic average of eight perimeter measurement points at a distance of 7 m (23 ft.), except Raw Exhaust data which is a single measurement point at 1 m (3.3 ft.) from the mouth of a straight pipe exhaust.

300REOZJ	60 Hz
-----------------	--------------

			Sound Pressure Levels dB(A)									
Load	Distance, m (ft.)	Enclosure	Measurement Position	Octave Band Center Frequency (Hz)								Overall Level
				63	125	250	500	1000	2000	4000	8000	
100% Load	7 (23)	Sound	Right	55.6	64.3	71.0	69.4	65.6	68.5	65.0	65.8	76.4
			Front-Right	56.2	63.8	66.6	68.2	62.1	62.8	58.6	58.7	72.8
			Front	57.1	65.3	68.8	68.4	64.3	64.9	62.4	61.7	74.6
			Front-Left	59.5	67.4	72.9	69.7	66.6	67.3	64.4	65.0	77.2
			Left	60.0	68.5	68.1	68.1	66.2	67.4	63.2	63.1	75.5
			Back-Left	55.5	66.5	71.3	67.5	65.2	66.0	62.9	62.4	75.5
			Back	58.3	67.2	72.8	67.8	65.9	68.2	63.9	64.1	76.7
			Back-Right	58.7	68.2	68.4	69.3	67.1	69.9	64.1	65.9	76.6
8-pos. log avg.				57.9	66.7	70.5	68.6	65.6	67.3	63.4	63.9	75.8

			Sound Pressure Levels dB(A)									
Load	Distance, m (ft.)	Enclosure	Measurement Position	Octave Band Center Frequency (Hz)								Overall Level
				63	125	250	500	1000	2000	4000	8000	
No Load	7 (23)	Sound	Right	49.4	61.4	64.9	66.0	62.3	63.6	57.8	49.0	71.2
			Front-Right	45.8	56.6	61.9	64.2	59.4	57.2	48.8	40.9	67.9
			Front	49.7	59.5	63.6	62.7	60.7	57.8	52.1	43.2	68.5
			Front-Left	50.3	61.0	65.3	65.5	63.7	61.9	56.3	46.7	71.0
			Left	51.9	62.0	66.3	63.6	61.9	61.7	54.6	46.8	70.7
			Back-Left	52.4	65.5	69.1	63.3	62.4	59.8	54.9	44.9	72.3
			Back	52.1	62.9	66.5	64.8	63.7	62.4	55.7	46.0	71.5
			Back-Right	50.7	63.1	66.7	65.8	63.1	64.4	55.5	47.4	72.0
8-pos. log avg.				50.7	62.1	66.0	64.6	62.4	61.7	55.1	46.2	70.9

KOHLER®

Emissions Data



300REOZJ

60 HZ. DIESEL INDUSTRIAL GENERATOR SET EMISSION DATA SHEET

ENGINE INFORMATION

Model:	John Deere, 6090HFG86A	Bore:	118.4mm (4.66 in.)
Nameplate BHP @ 1800 RPM:	463	Stroke:	136mm (5.35 in.)
Type:	4-Cycle, 6 Cylinder, Inline	Displacement:	9.0 L (548 cu. in.)
Aspiration:	Turbocharged, Charge Air-Cooled	EPA Family:	PJDXL09.0114
Compression Ratio	16.0:1	EPA Certificate:	PJDXL09.0114-011

PERFORMANCE DATA:

Engine bkW @ Stated Load
Fuel Consumption (g/kWh)
Exhaust Gas Flow (m³/min)
Exhaust Temperature (°C)

Table 1

1/4 Standby	1/2 Standby	3/4 Standby	Full Standby
86	173	259	345
247	240	215	205
			64
			497

EXHAUST EMISSION DATA:

HC (Total Unburned Hydrocarbons)
NOx (Oxides of Nitrogen as NO₂)
CO (Carbon Monoxide)
PM (Particulate Matter)

Table 2
EPA D2 Cycle 5-mode weighted

0.05
3.80
0.9
0.11

Values are in g/kWh unless otherwise noted

TEST METHODS AND CONDITIONS

The emission data listed is measured from a laboratory test engine according to the test procedures of 40 CFR 89 or 40 CFR 1039, as applicable. The test engine is intended to represent nominal production hardware, and there is no guarantee that every production engine will have identical test results. The family parent data represents multiple ratings and this data may have been collected at a different engine speed and load. Emission results may vary due to engine manufacturing tolerances, engine operating conditions, fuels used, alternate test methods, or other conditions.

Data and specifications subject to change without notice.



**UNITED STATES ENVIRONMENTAL PROTECTION AGENCY
2023 MODEL YEAR
CERTIFICATE OF CONFORMITY
WITH THE CLEAN AIR ACT**

**OFFICE OF TRANSPORTATION
AND AIR QUALITY
ANN ARBOR, MICHIGAN 48105**

Certificate Issued To: Deere & Company
(U.S. Manufacturer or Importer)
Certificate Number: PJDXL09.0114-011

Effective Date:
06/16/2022
Expiration Date:
12/31/2023

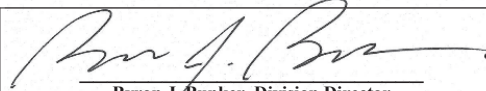
Byron J. Bunker, Division Director
Compliance Division

Issue Date:
06/16/2022
Revision Date:
N/A

Model Year: 2023
Manufacturer Type: Original Engine Manufacturer
Engine Family: PJDXL09.0114

Mobile/Stationary Indicator: Stationary
Emissions Power Category: 225<=kW<450
Fuel Type: Diesel
After Treatment Devices: No After Treatment Devices Installed
Non-after Treatment Devices: Electronic Control, Smoke Puff Limiter, Engine Design Modification, Non-standard Non-After Treatment Device Installed

Pursuant to Section 111 and Section 213 of the Clean Air Act (42 U.S.C. sections 7411 and 7547) and 40 CFR Part 60, and subject to the terms and conditions prescribed in those provisions, this certificate of conformity is hereby issued with respect to the test engines which have been found to conform to applicable requirements and which represent the following engines, by engine family, more fully described in the documentation required by 40 CFR Part 60 and produced in the stated model year.

This certificate of conformity covers only those new compression-ignition engines which conform in all material respects to the design specifications that applied to those engines described in the documentation required by 40 CFR Part 60 and which are produced during the model year stated on this certificate of the said manufacturer, as defined in 40 CFR Part 60.

It is a term of this certificate that the manufacturer shall consent to all inspections described in 40 CFR 1068 and authorized in a warrant or court order. Failure to comply with the requirements of such a warrant or court order may lead to revocation or suspension of this certificate for reasons specified in 40 CFR Part 60. It is also a term of this certificate that this certificate may be revoked or suspended or rendered void *ab initio* for other reasons specified in 40 CFR Part 60.

This certificate does not cover engines sold, offered for sale, or introduced, or delivered for introduction, into commerce in the U.S. prior to the effective date of the certificate.

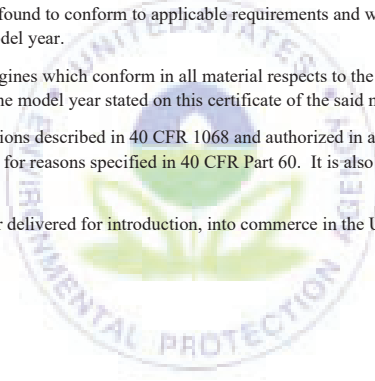

KOHLER®

Dimensional Drawings

INSTALLATION NOTE
 IF SUBBASE FUEL TANK AND/OR SOUND HOUSING IS USED, REFER TO SUBBASE FUEL TANK ADV TO DETERMINE MOUNTING LOCATIONS.

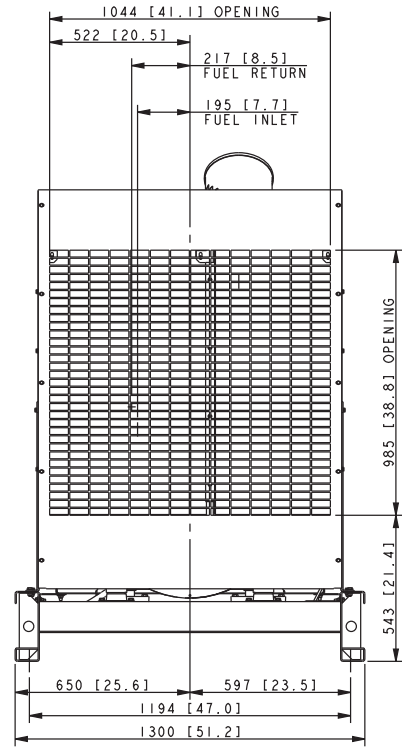
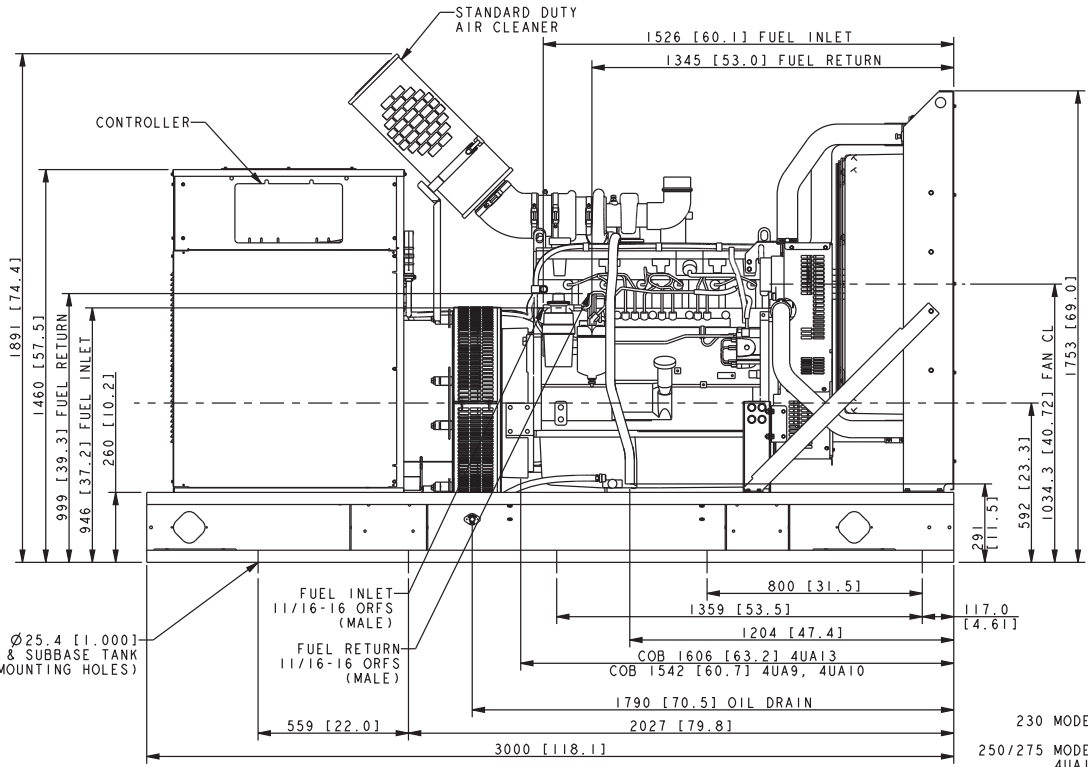

MODEL	ALT.	GENSET WEIGHT (WET)
230	4UA9	2268 Kg [5000 LBS]
250/275	4UA10	2313 Kg [5100 LBS]
230/250/ 275/300	4UA13	2449 Kg [5400 LBS]

- NOTES:**
- 1) WHEN SUBBASE TANK IS USED, CONDUIT MUST BE LOCATED OUTSIDE OF TANK AREA OR IN STUB-UP AREA FOR SUBBASE TANK. REFER TO SUBBASE ADV.
 - 2) DIMENSIONS IN [] ARE ENGLISH EQUIVALENTS.
 - 3) IF AN ENCLOSURE IS USED THE FUEL LINE MUST BE STUBBED UP FROM DIRECTLY UNDER THE UNIT OR BROUGHT IN FROM THE END OF THE SKID. REFER TO ENCLOSURE ADV.
 - 4) IF IBC CERTIFICATION IS REQUIRED SEE SEISMIC ADV FOR INSTALLATION INSTRUCTIONS.

REV	DATE	ON COMPOSITE DWGS. SEE PART NO. FOR REVISION LEVEL	BY	UNLESS OTHERWISE SPECIFIED: 25 DIMENSIONS ARE IN MILLIMETERS 27 TOLERANCES ARE: ±.13" ±.13" ±.13" ANGLES ± SURFACE FINISH MAX.	TITRE
-	9-27-10	NEW DRAWING [90099]	DJV		
A	11-10-10	(B-8) 1891 [74.4] DIM ADDED; (C-6) STANDARD DUTY AIR CLEANER NOTE ADDED; (D-4,8) ENCLOSED GENSETS ONLY NOTE ADDED; SHEET 2 ADDED.	DJV		
B	8-22-11	(C-5) 3/8-18 WAS 1/2-14 SUPPLY [92115]	DJV		

APPROVALS	DATE	KOHLER CO. METRIC PRO-E POWER SYSTEMS, KOHLER, WI 53044 U.S.A. THIS DRAWING IN DESIGN AND DETAIL IS KOHLER CO. PROPERTY AND MUST NOT BE USED EXCEPT IN CONNECTION WITH KOHLER CO. WORK. ALL RIGHTS OF DESIGN OR INVENTION ARE RESERVED. DIMENSION PRINT, 230-300 JD SCALE 0.11 CAD NO. SHEET 1 of 2 DWG NO. ADV-7900
CHECKED	DATE	
APPROVED	DATE	

230 MODEL, 60 HZ 4UA9
 250/275 MODEL, 60 HZ 4UA10, 4UA13
 300 MODEL, 60 HZ, 4UA13
 RECONN. & 600V ALTERNATORS
 JOHN DEERE 6090HF, TIER III

MODEL	ENCLOSURE WEIGHT KG [LBS]
STEEL WEATHER	363 [800]
STEEL SOUND	386 [850]
ALUMINIUM SOUND	238 [525]

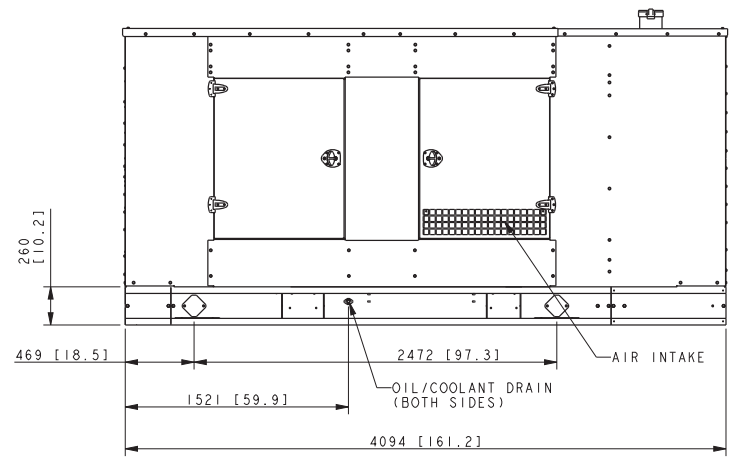
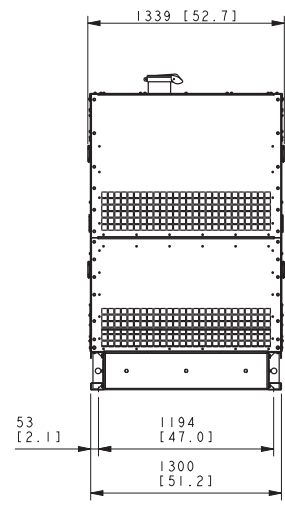
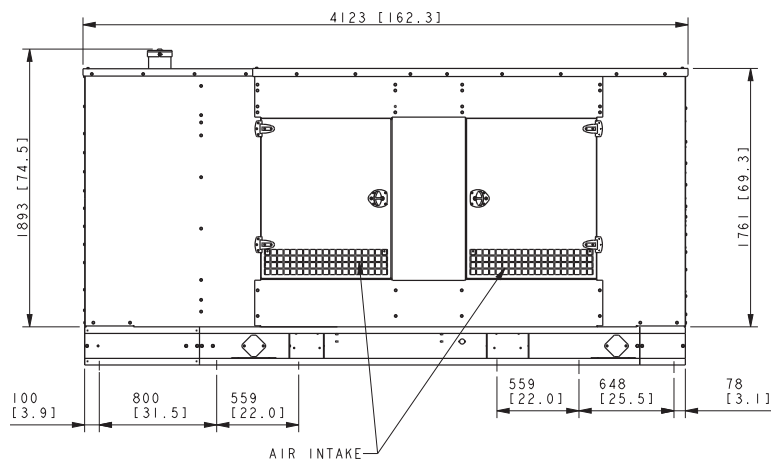
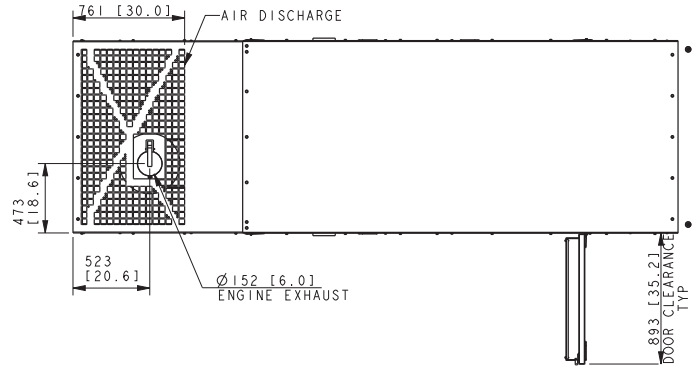

- NOTE:**
1. IF STANDARD TANK IS ORDERED, ENCLOSURE MOUNTS DIRECTLY TO TANK
 2. IF STATE TANK IS ORDERED, TANK MOUNTS BELOW SKID
 3. TANK MAY EXTEND BEYOND ENCLOSURE (DISCHARGE END ONLY)
 4. FOR STUB-UP ACCESS DURING INSTALLATION THE REAR ENCLOSURE PANEL SHOULD BE REMOVED.

230-300 MODEL
JOHN DEERE TIER III

REV	DATE	ON COMPOSITE DWGS. SEE PART NO. FOR REVISION LEVEL	BY	UNLESS OTHERWISE SPECIFIED: 1) DIMENSIONS ARE IN MILLIMETERS 2) TOLERANCES ARE: F 2-5-13 (A-1) 1-4 WAS 1-2, SEE SHEET 3 AND 4 [CT32174] G 8-4-17 (D-6) DIM. Ø152.4 (6.00) ADDED [CT177004] H 11-22-18 VIEWS UPDATED, SEE SHEET 2, 3 & 4 [CT191932]	CHK	DATE	APPROVALS	DATE	TITLE
E	10-31-12	SHEET 2 WAS SHEET 1, ADDED SHEET 1 [CT28612]	CEK			10-24-08		10-24-08	DIMENSION PRINT 230-300KW JD
F	2-5-13	(A-1) 1-4 WAS 1-2, SEE SHEET 3 AND 4 [CT32174]	SAM			10-24-08		10-24-08	
G	8-4-17	(D-6) DIM. Ø152.4 (6.00) ADDED [CT177004]	SRM			10-24-08		10-24-08	
H	11-22-18	VIEWS UPDATED, SEE SHEET 2, 3 & 4 [CT191932]	YPM			10-24-08		10-24-08	

KOHLER CO. METRIC PRO-E
POWER SYSTEMS, KOHLER, WI 53044 U.S.A.
THIS DRAWING IN DESIGN AND DETAIL IS KOHLER CO. PROPERTY AND MUST NOT BE USED EXCEPT IN CONNECTION WITH KOHLER CO. WORK. ALL RIGHTS OF DESIGN OR INVENTION ARE RESERVED.
SCALE 0.06 CAD NO. SHEET 1 of 4
ADV-7644 D

PART NO.	REV	ITEM 1	ITEM 2	ITEM 3	COMMENTS
GM85123-1	C	GM85127	GM85129	GM86126-1	MULTIPLE ATS
GM85123-2	C	GM85131	GM85129	GM86126-2	SINGLE ATS
GM85123-3	C	GM85132	-	GM86126-3	ANNUNCIATOR ONLY
GM85123-4	C	GM85133	-	GM86126-3	SDMO - ANNUNCIATOR ONLY

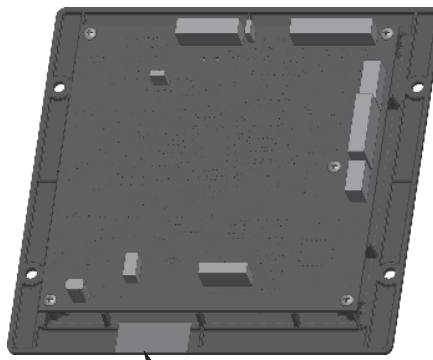
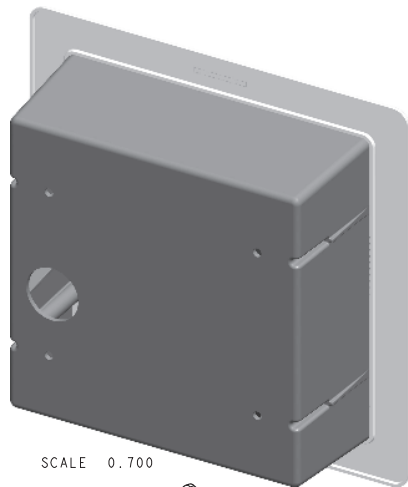

- NOTES:
- FUNCTIONALLY TEST ACCORDING TO ISO DOCUMENT ETF-WI-001, PER SPECIFICATION ETF-TD-003.
 - ASSEMBLE PCBA TO BACK OF BEZEL USING FIXTURE JT-0001.
 - TORQUE ALL SCREWS TO 7-10 in lbs.
 - PEEL BACKING OFF FACE PLATE AND APPLY TO BEZEL. APPLY EVEN PRESSURE TO ENTIRE SURFACE TO ENSURE COMPLETE ADHESION.

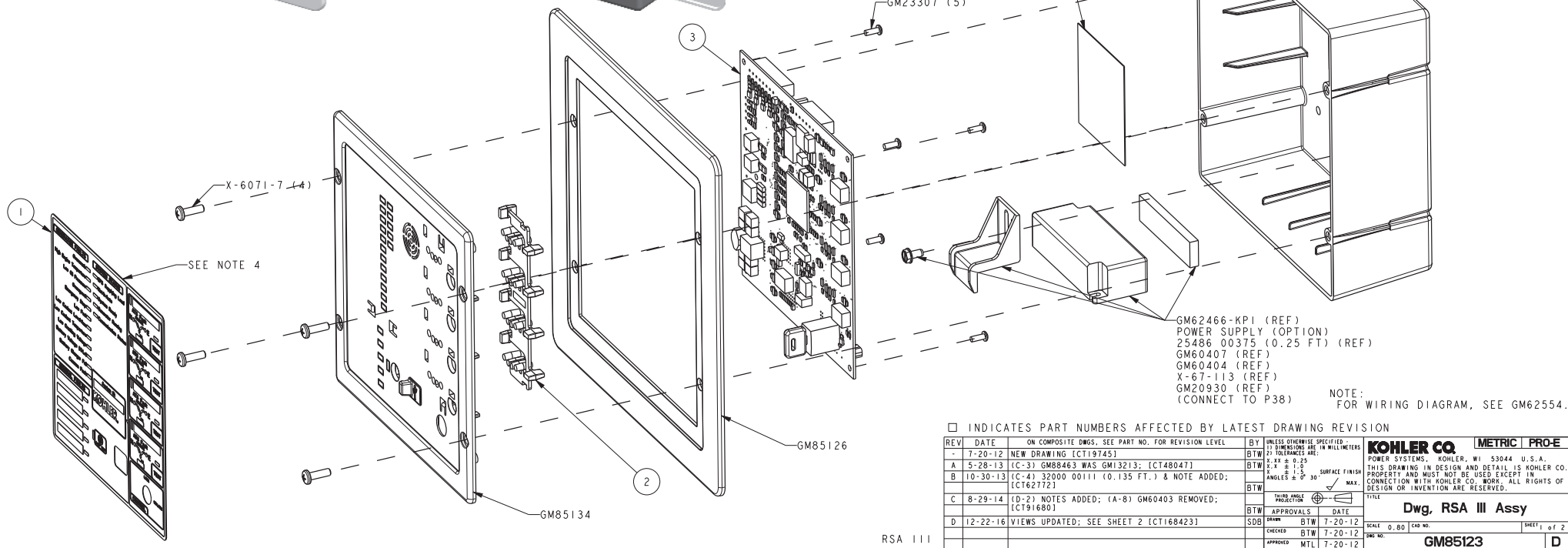

□ INDICATES PART NUMBERS AFFECTED BY LATEST DRAWING REVISION

REV	DATE	ON COMPOSITE DWGS. SEE PART NO. FOR REVISION LEVEL	BY	UNLESS OTHERWISE SPECIFIED: 2) DIMENSIONS ARE IN MILLIMETERS
-	7-20-12	NEW DRAWING [CT19745]	BTW	2) TOLERANCES ARE: X .XX ± 0.25 Y .X ± 0.15 Z .X ± 0.15 SURFACE FINISH ANGLES ± 0° 30' / MAX.
A	5-28-13	(C-3) GM88463 WAS GM13213; [CT48047]	BTW	
B	10-30-13	(C-4) 32000 00111 (0.135 FT.) & NOTE ADDED; [CT62772]	BTW	
C	8-29-14	(D-2) NOTES ADDED; (A-8) GM60403 REMOVED; [CT191680]	BTW	
D	12-22-16	VIEWS UPDATED; SEE SHEET 2 [CT1684231]	BTW	

APPROVALS	DATE
BTW	7-20-12
SDH	7-20-12
BTW	7-20-12
MTL	7-20-12

KOHLER CO. METRIC PRO-E	
POWER SYSTEMS, KOHLER, WI 53044 U.S.A.	
THIS DRAWING IN DESIGN AND DETAIL IS KOHLER CO. PROPERTY AND MUST NOT BE USED EXCEPT IN CONNECTION WITH KOHLER CO. WORK. ALL RIGHTS OF DESIGN OR INVENTION ARE RESERVED.	
TITLE	Dwg, RSA III Assy
SCALE	0.80
CAD NO.	
DWG NO.	GM85123
SHEET	1 of 2

RSA III

8 7 6 5 4 3 2 1

SNAP ITEM 2 INTO THIS LOCATION BEING SURE TO LINE-UP ALL LIGHT PIPES TO MATCHING SOCKETS ON BEZEL.

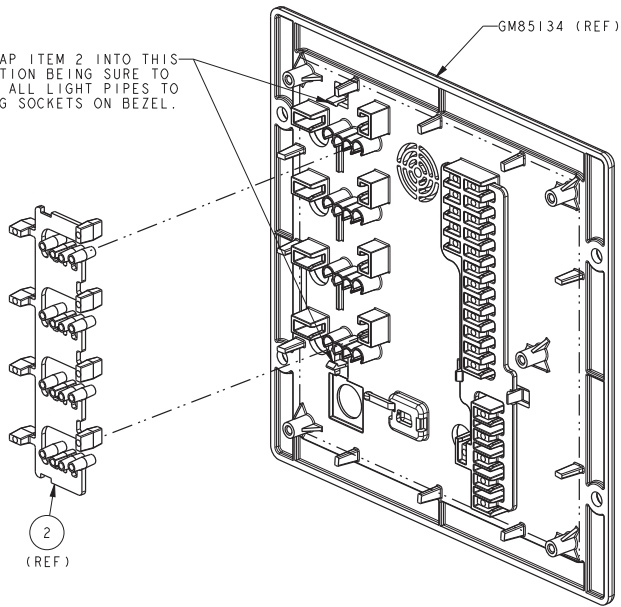

BACK VIEW OF BEZEL
SCALE 1.000

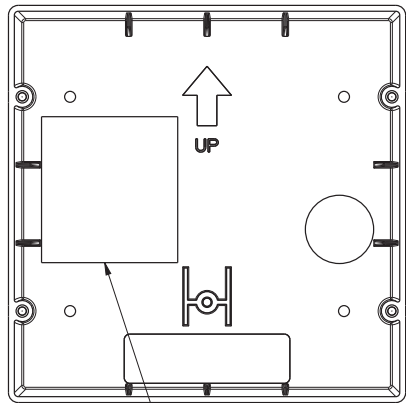

VIEW B
FRONT OF BOX

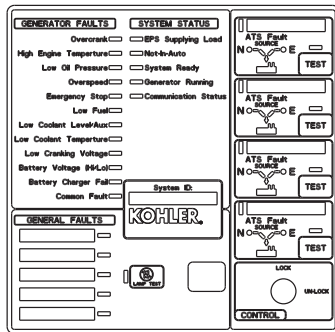

ITEM 1
P/N: GM85127 REF

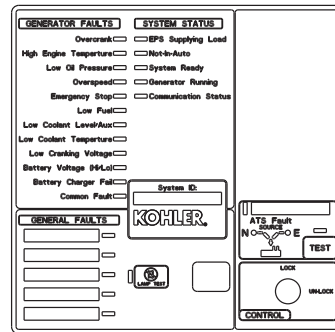

ITEM 1
P/N: GM85131 REF

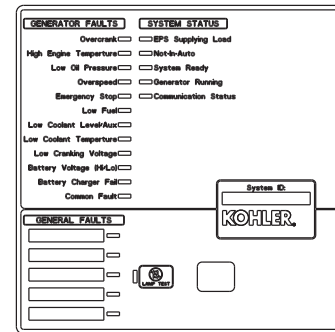

ITEM 1
P/N: GM85132 REF

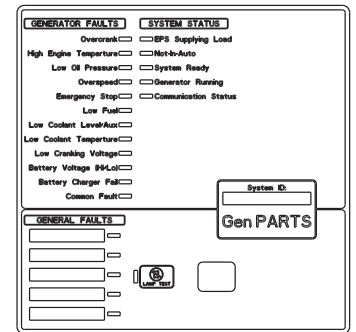

ITEM 1
P/N: GM85133 REF

REV	DATE	ON COMPOSITE DWGS. SEE PART NO. FOR REVISION LEVEL	BY	UNLESS OTHERWISE SPECIFIED: 2D DIMENSIONS ARE IN MILLIMETERS 2.5 TOLERANCES ARE: X .XX ± 0.25 Y .X ± 1.5 SURFACE FINISH ANGLES ± 0° 30' / MAX.	TITLE
-	7-30-12	NEW DRAWING [CT19745]	BTW		KOHLER CO. METRIC PRO-E POWER SYSTEMS, KOHLER, WI 53044 U.S.A. THIS DRAWING IN DESIGN AND DETAIL IS KOHLER CO. PROPERTY AND MUST NOT BE USED EXCEPT IN CONNECTION WITH KOHLER CO. WORK. ALL RIGHTS OF DESIGN OR INVENTION ARE RESERVED. Dwg. RSA III Assy SCALE 0.80 CAD NO. SHEET 2 of 2 TAG NO. GM85123
A	5-28-13	(A-8) GM88463 (REF) WAS GM13213 (REF); [CT48047]	BTW		
B	10-30-13	SEE SHEET 1 [CT62772]	BTW		
C	8-29-14	VIEW A REMOVED; [CT91680]	BTW		
D	12-22-16	VIEWS UPDATED; SEE SHEET 1 [CT168423]	SDR	APPROVALS DATE	
			DRW	BTW 7-30-12	
			CHECKED	BTW 7-30-12	
			APPROVED	MTL 7-30-12	

8 7 6 5 4 3 2 1

MODEL	CAPACITY L (GAL)	WEIGHT KG (LBS)	HEIGHT MM (IN)	LENGTH MM (IN)	E - VENTS SIZE (QTY)
230-300kW	2102 L [555 GAL]	1242 KG [2738 LBS]	635 MM [25 IN]	5008 MM [197.2 IN]	5 (2)
230-275kW	3573 L [944 GAL]	1851 KG [4081 LBS]	914.4 MM [36 IN]	5325 MM [209.7 IN]	5 (2)

THIS IS AN AUTOMATED TABLE. ALL CHANGES TO THIS TABLE MUST BE MADE IN THE FAMILY TABLE OF THE GENERIC MODEL.

TANK FITTINGS:

- A. EMERGENCY VENT FITTING PER NFPA 30 WITH VENT CAPS (QTY 2).
- B. 2" NPT FUEL FILL FITTING WITH LOCKABLE CAP AND 2" RISER.
- C. 2" NPT FUEL LEVEL GAUGE FITTING WITH DIRECT READING MECHANICAL GAUGE.
- D. 2" NPT NORMAL VENT FITTING WITH MUSHROOM VENT CAP AND 5" RISER.
- E. 2" NPT FITTING FOR REMOVABLE ENGINE SUPPLY DIP TUBE (3/8" NPT FEMALE WITH CHECK VALVE).
- F. 2" NPT FITTING FOR REMOVABLE FUEL RETURN DIP TUBE (3/8" NPT FEMALE).
- H. 2" NPT FOR LOW LEVEL SWITCH (SET AT 50% FULL, SILICONE PACKED).
- J. 2" NPT ADDITIONAL FITTING FOR OPTIONAL ACCESSORY (INSTALL STEEL 2" NPT PIPE PLUG).
- M. 2" NPT BASIN DRAIN (INSTALL STEEL 2" NPT PIPE PLUG).
- N. 2" NPT FOR FUEL IN BASIN SWITCH.
- P. 2" NPT ADDITIONAL FITTING FOR OPTIONAL ACCESSORY (INSTALL STEEL 2" NPT PIPE PLUG).

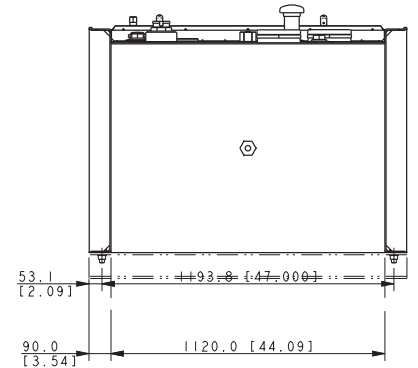
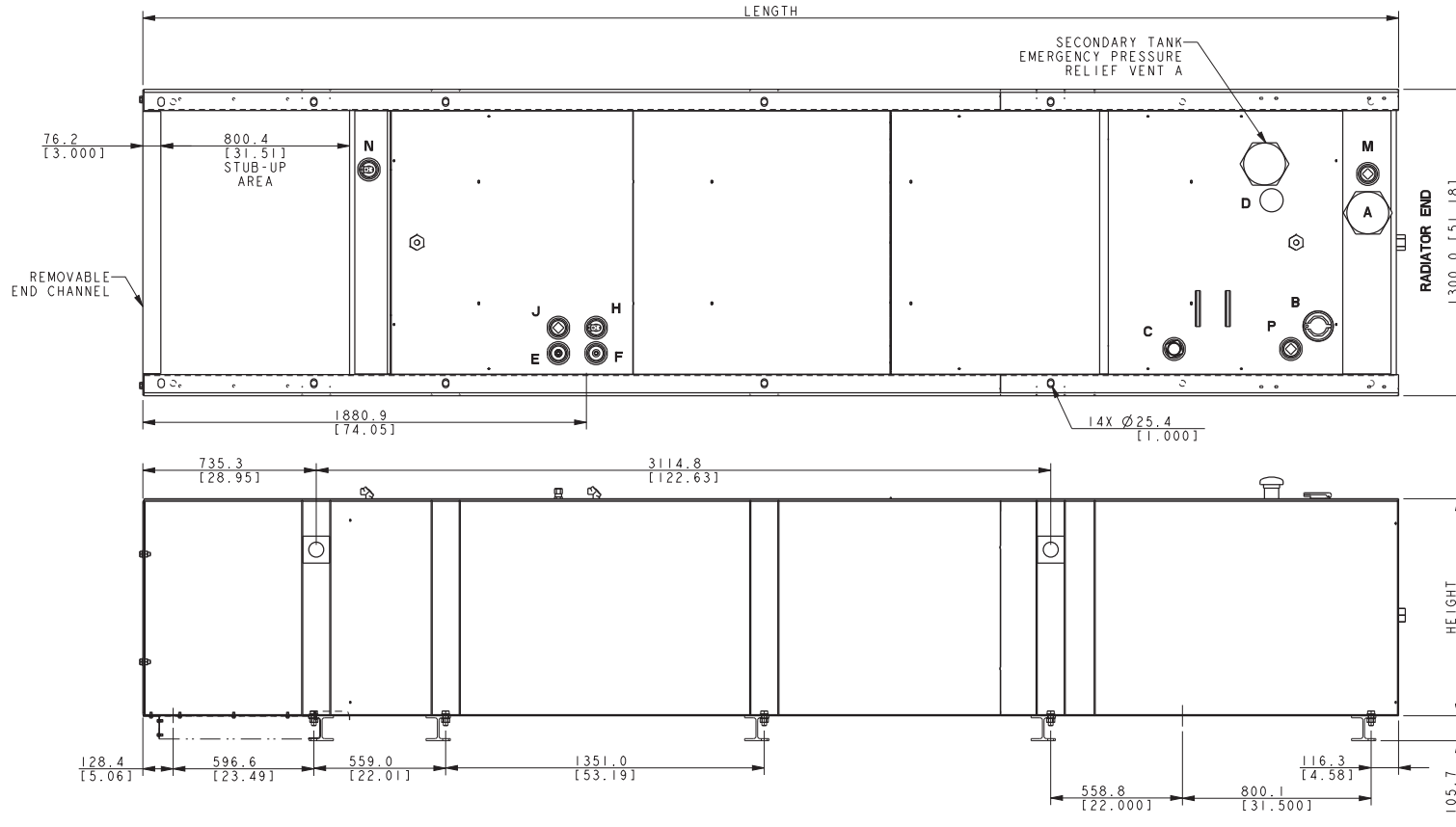

NOTE:
FOR FURTHER TANK DETAIL
SEE INDIVIDUAL DRAWINGS.

**230-300KW
JOHN DEERE TIER III
STATE CODE TANK**

REV	DATE	ON COMPOSITE DWGS. SEE PART NO. FOR REVISION LEVEL	BY	UNLESS OTHERWISE SPECIFIED: 2) DIMENSIONS ARE IN MILLIMETERS 2) TOLERANCES ARE: 2-1X ± 0.25 2-14 ± 0.13 SURFACE FINISH ANGLES ± 0° 30' / MAX.	TITLE
A	11-18-09	SEE SHEET 1 OF 2. (D-7) 800.4 ADDED. [8848]	GFR		KOHLER CO. METRIC PRO-E POWER SYSTEMS, KOHLER, WI 53044 U.S.A. THIS DRAWING IN DESIGN AND DETAIL IS KOHLER CO. PROPERTY AND MUST NOT BE USED EXCEPT IN CONNECTION WITH KOHLER CO. WORK. ALL RIGHTS OF DESIGN OR INVENTION ARE RESERVED. DIMENSION PRINT SCALE 0.10 CAD NO. SHEET 2 of 3 DWG NO. ADV-7645
B	10-7-10	(D-8) STATE TANK TABLE ADDED [90099-6]	RJS		
C	12-2-11	VIEWS UPDATED [92417-5]	SOS		
D	5-8-12	SEE SHEET 3, (D-8) 300 KW MOVED TO SHEET 3, (D-3) FITTING NOTES REVISED [CT13297]	JB2		
E	10-21-15	SEE SHEET 3 OF 3. [CT128239]	GFR		
F	11-17-17	SEE SHEET 1 [CT181456]	JB2		
G	7-31-19	(D-5) EMERGENCY VENTS FOR 555 GAL: 5" WAS 4" [CT197533]	PAS		

KOHLER®

Wiring Schematics

REV	DATE	REVISION	BY
A	10-11-18	SEE SHEET 2 (CT191090)	TJL
B	2-05-19	SEE SHEETS 10 & 11 (CT193517)	SMH
C	3-18-19	(A-1, -2) CHART UPDATED FOR SPEED AND VOLTAGE BIAS; SEE SHEET 2 (CT194006)	SMH
D	5-13-19	(A, B, C-1) TB12-19 THRU 44 ADDED, WOKED VOLTAGE AND SPEED BIAS ON TB12; SEE SHEET 2 (CT195241)	TEV
E	9-10-19	SEE SHEET 2 (CT195508)	TEV

REV	DATE	REVISION	BY
A	10-11-18	SEE SHEET 2 (CT191090)	TJL
B	2-05-19	SEE SHEETS 10 & 11 (CT193517)	SMH
C	3-18-19	(A-1, -2) CHART UPDATED FOR SPEED AND VOLTAGE BIAS; SEE SHEET 2 (CT194006)	SMH
D	5-13-19	(A, B, C-1) TB12-19 THRU 44 ADDED, WOKED VOLTAGE AND SPEED BIAS ON TB12; SEE SHEET 2 (CT195241)	TEV
E	9-10-19	SEE SHEET 2 (CT195508)	TEV

REV	DATE	REVISION	BY
A	10-11-18	SEE SHEET 2 (CT191090)	TJL
B	2-05-19	SEE SHEETS 10 & 11 (CT193517)	SMH
C	3-18-19	(A-1, -2) CHART UPDATED FOR SPEED AND VOLTAGE BIAS; SEE SHEET 2 (CT194006)	SMH
D	5-13-19	(A, B, C-1) TB12-19 THRU 44 ADDED, WOKED VOLTAGE AND SPEED BIAS ON TB12; SEE SHEET 2 (CT195241)	TEV
E	9-10-19	SEE SHEET 2 (CT195508)	TEV

REV	DATE	REVISION	BY
A	10-11-18	SEE SHEET 2 (CT191090)	TJL
B	2-05-19	SEE SHEETS 10 & 11 (CT193517)	SMH
C	3-18-19	(A-1, -2) CHART UPDATED FOR SPEED AND VOLTAGE BIAS; SEE SHEET 2 (CT194006)	SMH
D	5-13-19	(A, B, C-1) TB12-19 THRU 44 ADDED, WOKED VOLTAGE AND SPEED BIAS ON TB12; SEE SHEET 2 (CT195241)	TEV
E	9-10-19	SEE SHEET 2 (CT195508)	TEV

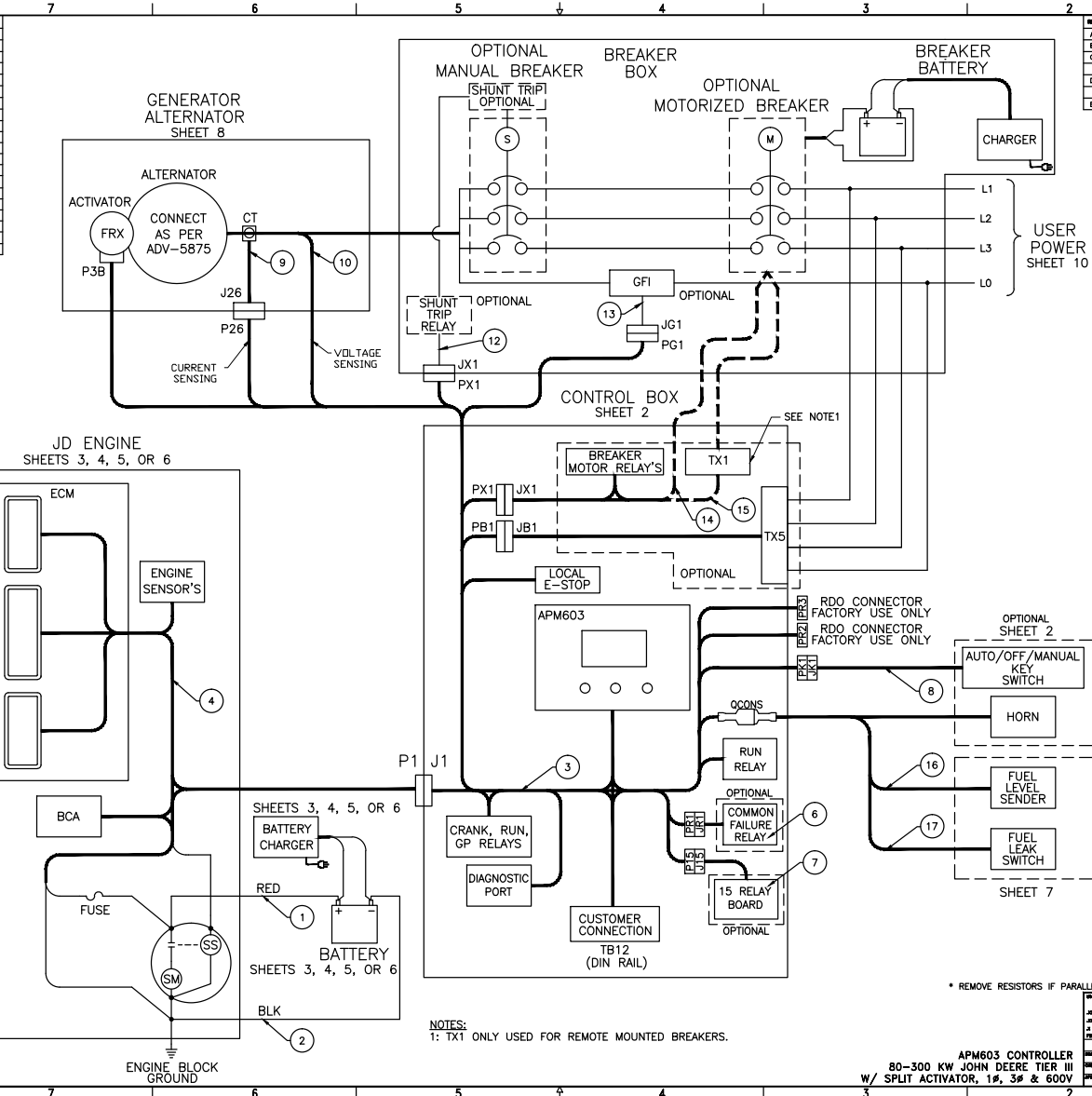

REV	DATE	REVISION	BY
A	10-11-18	SEE SHEET 2 (CT191090)	TJL
B	2-05-19	SEE SHEETS 10 & 11 (CT193517)	SMH
C	3-18-19	(A-1, -2) CHART UPDATED FOR SPEED AND VOLTAGE BIAS; SEE SHEET 2 (CT194006)	SMH
D	5-13-19	(A, B, C-1) TB12-19 THRU 44 ADDED, WOKED VOLTAGE AND SPEED BIAS ON TB12; SEE SHEET 2 (CT195241)	TEV
E	9-10-19	SEE SHEET 2 (CT195508)	TEV

FUNCTION	POS	SIGNAL DESCRIPTION
REMOTE E-STOP	1	REMOTE EMERGENCY STOP
REMOTE START	2	REMOTE START SIGNAL
CUSTOMER INTERFACE	5	FUSED BATTERY POWER
CUSTOMER INTERFACE	6	BATT VOLTS WHEN RUNNING
CUSTOMER INTERFACE	7	BATTERY NEGATIVE
CUSTOMER INTERFACE	8	A (-) ISOLATED
CUSTOMER INTERFACE	9	B (+) RS-485 #2 (MODBUS/PGEN)
CUSTOMER INTERFACE	10	SHIELD
RES IN RETURN	11	LOW FUEL LEVEL SWITCH
RES IN RETURN	12	LOW FUEL LEVEL SWITCH RETURN
BATT CHRG FLT	13	BATTERY CHARGER FAULT
RES IN RETURN	14	BATTERY CHARGER FAULT RETURN
AUX WARNING	15	AUXILIARY WARNING
RES IN RETURN	16	AUXILIARY WARNING RETURN
AUX FAULT	17	AUXILIARY FAULT
RES IN RETURN	18	AUXILIARY FAULT RETURN
CUSTOMER INTERFACE	19	A (-) ISOLATED
CUSTOMER INTERFACE	20	B (+) RS-485 #3 (MODBUS/PGEN)
CUSTOMER INTERFACE	21	SHIELD
CUSTOMER INTERFACE	22	A (-) NON-ISOLATED
CUSTOMER INTERFACE	23	B (+) RS-485 #4 (MODBUS RSA)
CUSTOMER INTERFACE	24	SHIELD
RUN RELAY	25	COMMON CONTACT
RUN RELAY	26	NORMALLY OPEN CONTACT
RUN RELAY	27	NORMALLY CLOSED CONTACT
SPEED BIAS	28	SPEED BIAS (+)
SPEED BIAS	29	SPEED BIAS (-)
VOLTAGE BIAS	30	SHIELD
VOLTAGE BIAS	31	VOLTAGE BIAS (+)
VOLTAGE BIAS	32	VOLTAGE BIAS (-)
SPARE	33	SHIELD
SPARE	34	SPARE
SPARE	35	SPARE
DROOP SELECT	36	ISOCHRONOUS DROOP
ANALOG THROTTLE CONTROL	37	JP2 IN JP2 OUT +5 VDC REF
SPARE	38	SIGNAL (+2.5 VDC NORM)
SPARE	39	SENSOR RETURN
SPARE	40	CONSULT FACTORY
SPARE	41	SPARE
SPARE	42	SPARE
SPARE	43	SPARE
SPARE	44	SPARE

REV	DATE	REVISION	BY
A	10-11-18	SEE SHEET 2 (CT191090)	TJL
B	2-05-19	SEE SHEETS 10 & 11 (CT193517)	SMH
C	3-18-19	(A-1, -2) CHART UPDATED FOR SPEED AND VOLTAGE BIAS; SEE SHEET 2 (CT194006)	SMH
D	5-13-19	(A, B, C-1) TB12-19 THRU 44 ADDED, WOKED VOLTAGE AND SPEED BIAS ON TB12; SEE SHEET 2 (CT195241)	TEV
E	9-10-19	SEE SHEET 2 (CT195508)	TEV

REV	DATE	REVISION	BY
A	10-11-18	SEE SHEET 2 (CT191090)	TJL
B	2-05-19	SEE SHEETS 10 & 11 (CT193517)	SMH
C	3-18-19	(A-1, -2) CHART UPDATED FOR SPEED AND VOLTAGE BIAS; SEE SHEET 2 (CT194006)	SMH
D	5-13-19	(A, B, C-1) TB12-19 THRU 44 ADDED, WOKED VOLTAGE AND SPEED BIAS ON TB12; SEE SHEET 2 (CT195241)	TEV
E	9-10-19	SEE SHEET 2 (CT195508)	TEV

REV	DATE	REVISION	BY
A	10-11-18	SEE SHEET 2 (CT191090)	TJL
B	2-05-19	SEE SHEETS 10 & 11 (CT193517)	SMH
C	3-18-19	(A-1, -2) CHART UPDATED FOR SPEED AND VOLTAGE BIAS; SEE SHEET 2 (CT194006)	SMH
D	5-13-19	(A, B, C-1) TB12-19 THRU 44 ADDED, WOKED VOLTAGE AND SPEED BIAS ON TB12; SEE SHEET 2 (CT195241)	TEV
E	9-10-19	SEE SHEET 2 (CT195508)	TEV

NOTES:
1: TX1 ONLY USED FOR REMOTE MOUNTED BREAKERS.

* REMOVE RESISTORS IF PARALLELING

APPROVALS	DATE
DESIGNED BY: ABS	3-12-18
CHECKED BY: BTW	3-12-18
APPROVED BY: JLS	5-12-18

REV	DATE	REVISION	BY
1	10-11-18	ISSUED FOR REV. 1	TJL
2	03-04-19	ISSUED FOR REV. 2	SMH
3	03-12-18	ISSUED FOR REV. 3	SMH
4	03-12-18	ISSUED FOR REV. 4	SMH
5	03-12-18	ISSUED FOR REV. 5	SMH
6	03-12-18	ISSUED FOR REV. 6	SMH
7	03-12-18	ISSUED FOR REV. 7	SMH
8	03-12-18	ISSUED FOR REV. 8	SMH
9	03-12-18	ISSUED FOR REV. 9	SMH
10	03-12-18	ISSUED FOR REV. 10	SMH
11	03-12-18	ISSUED FOR REV. 11	SMH
12	03-12-18	ISSUED FOR REV. 12	SMH
13	03-12-18	ISSUED FOR REV. 13	SMH
14	03-12-18	ISSUED FOR REV. 14	SMH
15	03-12-18	ISSUED FOR REV. 15	SMH
16	03-12-18	ISSUED FOR REV. 16	SMH
17	03-12-18	ISSUED FOR REV. 17	SMH
18	03-12-18	ISSUED FOR REV. 18	SMH
19	03-12-18	ISSUED FOR REV. 19	SMH
20	03-12-18	ISSUED FOR REV. 20	SMH
21	03-12-18	ISSUED FOR REV. 21	SMH
22	03-12-18	ISSUED FOR REV. 22	SMH
23	03-12-18	ISSUED FOR REV. 23	SMH
24	03-12-18	ISSUED FOR REV. 24	SMH
25	03-12-18	ISSUED FOR REV. 25	SMH
26	03-12-18	ISSUED FOR REV. 26	SMH
27	03-12-18	ISSUED FOR REV. 27	SMH
28	03-12-18	ISSUED FOR REV. 28	SMH
29	03-12-18	ISSUED FOR REV. 29	SMH
30	03-12-18	ISSUED FOR REV. 30	SMH
31	03-12-18	ISSUED FOR REV. 31	SMH
32	03-12-18	ISSUED FOR REV. 32	SMH
33	03-12-18	ISSUED FOR REV. 33	SMH
34	03-12-18	ISSUED FOR REV. 34	SMH
35	03-12-18	ISSUED FOR REV. 35	SMH
36	03-12-18	ISSUED FOR REV. 36	SMH
37	03-12-18	ISSUED FOR REV. 37	SMH
38	03-12-18	ISSUED FOR REV. 38	SMH
39	03-12-18	ISSUED FOR REV. 39	SMH
40	03-12-18	ISSUED FOR REV. 40	SMH
41	03-12-18	ISSUED FOR REV. 41	SMH
42	03-12-18	ISSUED FOR REV. 42	SMH
43	03-12-18	ISSUED FOR REV. 43	SMH
44	03-12-18	ISSUED FOR REV. 44	SMH

APM603 CONTROLLER
80-300 KW JOHN DEERE TIER III
W/ SPLIT ACTIVATOR, 1#, 3# & 600V
ADV-9057

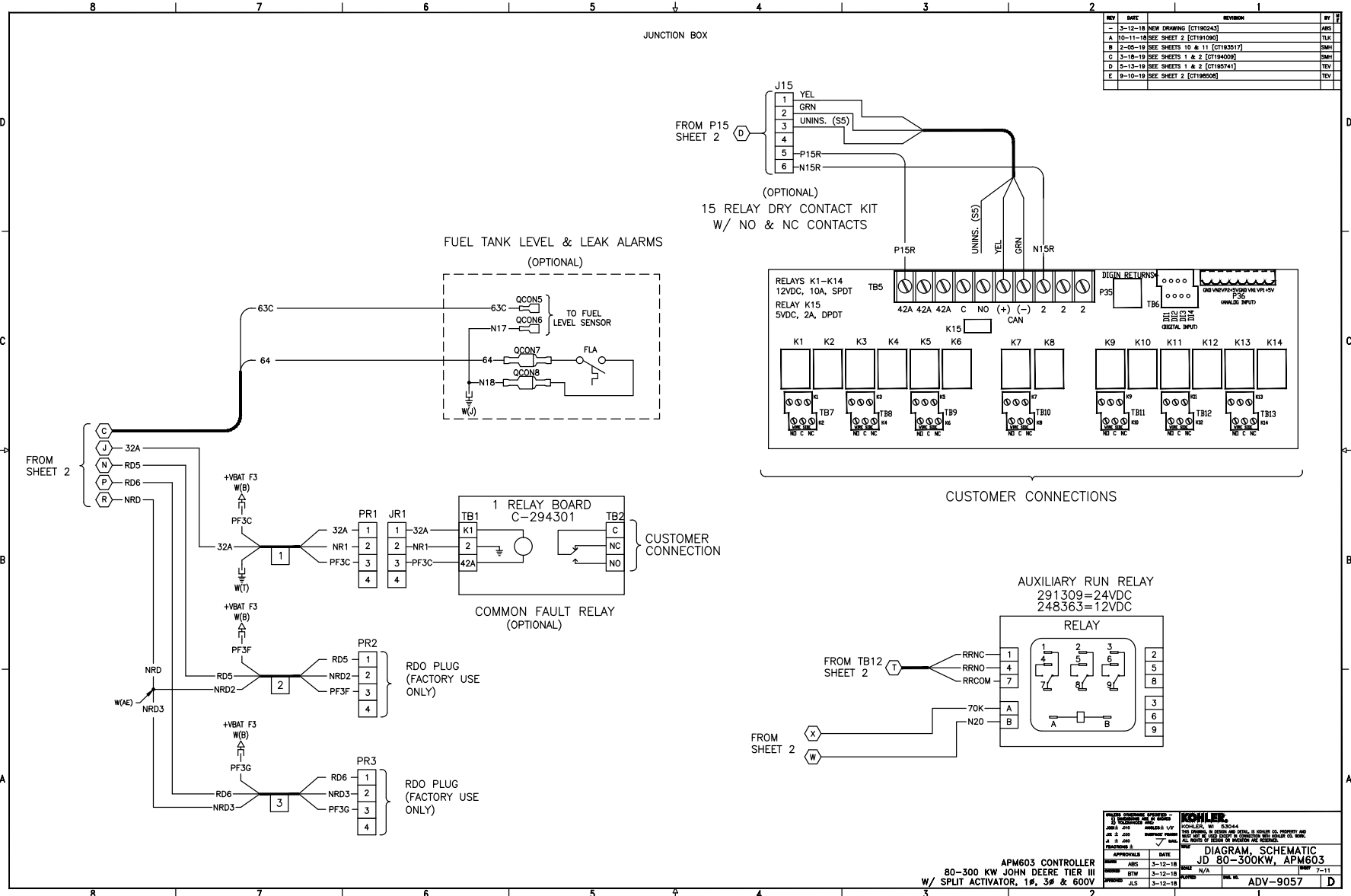

REV	DATE	REVISION	BY
1	3-12-18	NEW DRAWING (C7190243)	JAS
A	10-11-18	SEE SHEET 2 (C7191090)	TLK
B	2-05-19	SEE SHEETS 10 & 11 (C7182517)	SMH
C	3-18-19	SEE SHEETS 1 & 2 (C7194009)	SMH
D	5-13-19	SEE SHEETS 1 & 2 (C7195741)	TEV
E	9-10-19	SEE SHEET 2 (C7198500)	TEV

J. SCHLESINGER JAS JLS JLS	DATE 3-12-18 3-12-18 3-12-18	REVISION N/A N/A N/A	BY JLS JLS JLS
APPROVALS JLS		DATE 3-12-18	
APM603 CONTROLLER 80-300 KW JOHN DEERE TIER III W/ SPLIT ACTIVATOR, 1#, 3# & 600V		KOHLER, WI 53044 1800 W. STATE ST. STE. 100 ALL RIGHTS RESERVED. NO REPRODUCTION OR TRANSMISSION OF THIS DOCUMENT IS PERMITTED WITHOUT THE WRITTEN CONSENT OF KOHLER.	
DIAGRAM, SCHEMATIC JD 80-300KW, APM603		SHEET 7-11 ADV-9057	

ALTERNATOR

REV	DATE	REVISION	BY
-	3-12-18	NEW DRAWING [C7190243]	JAS
A	10-11-18	SEE SHEET 2 [C7191090]	TLK
B	2-05-19	SEE SHEETS 10 & 11 [C7193517]	SMH
C	3-18-19	SEE SHEETS 1 & 2 [C7194009]	SMH
D	5-13-19	SEE SHEETS 1 & 2 [C7193741]	TEV
E	9-10-19	SEE SHEET 2 [C7198500]	TEV

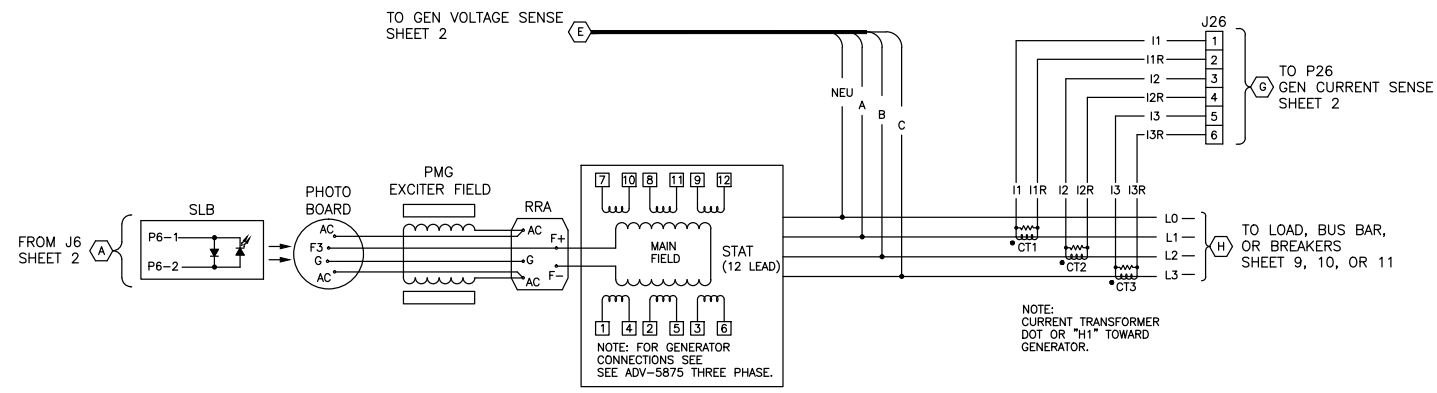

APPROVALS	DATE	BY
JAS	3-12-18	JAS
TLK	10-11-18	TLK
SMH	2-05-19	SMH
SMH	3-18-19	SMH
TEV	5-13-19	TEV
TEV	9-10-19	TEV

KOHLER KOHLER, WI 53044 THE COMPANY IS OFFERED BY KTM, A DIVISION OF INVERTECH AND ALL RIGHTS ARE RESERVED BY KTM.	
ALTERNATOR SIDE APM603 CONTROLLER 80-300 KW JOHN DEERE TIER III W/ SPLIT ACTIVATOR, 1#, 3# & 600V	DIAGRAM, SCHEMATIC JD 80-300KW, APM603 ADV-9057

ALTERNATOR SIDE
 APM603 CONTROLLER
 80-300 KW JOHN DEERE TIER III
 W/ SPLIT ACTIVATOR, 1#, 3# & 600V

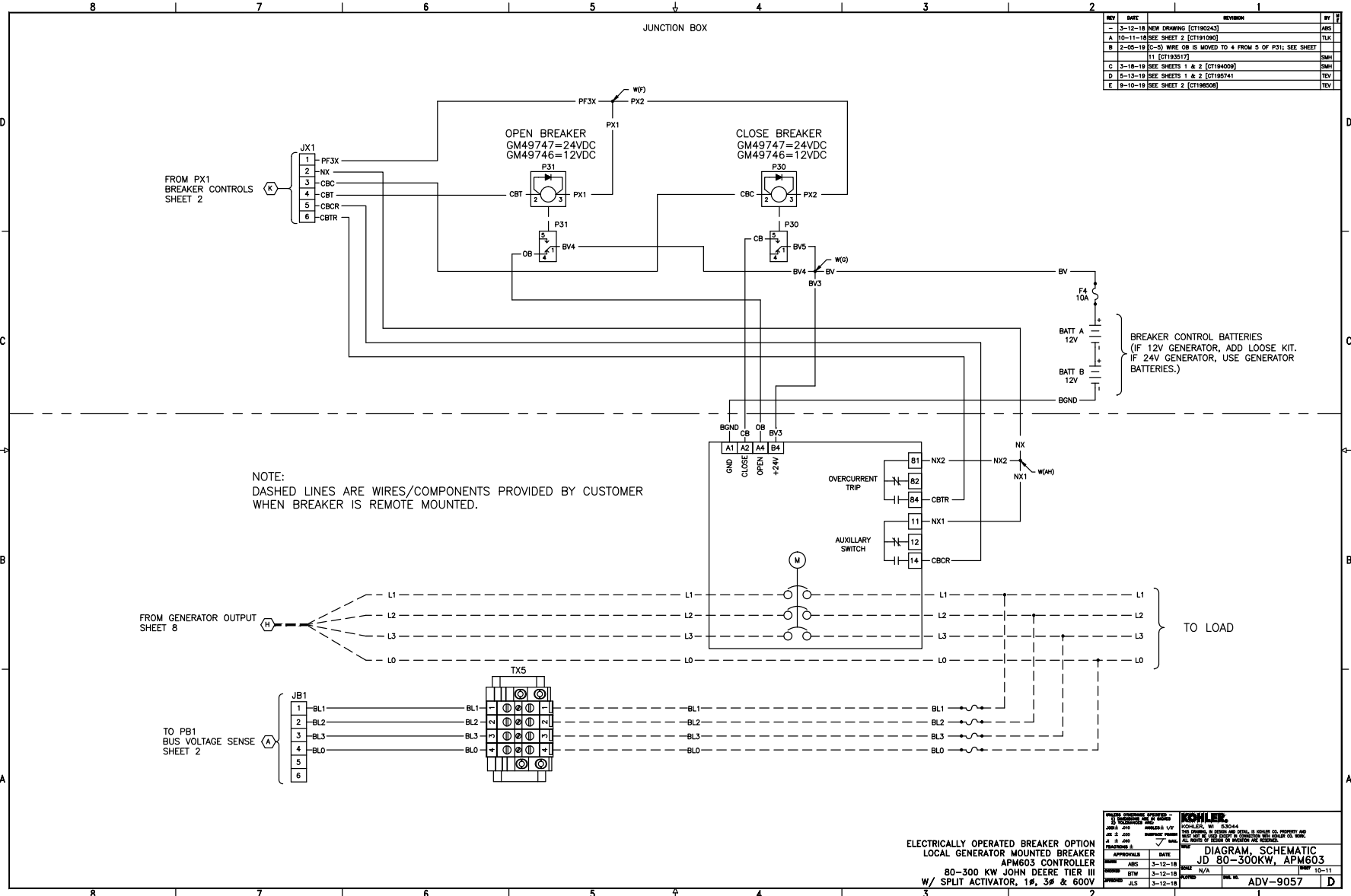

REV	DATE	REVISION	BY
1	3-12-18	NEW DRAWING [C1192343]	ABS
A	10-11-18	SEE SHEET 2 [C1191090]	TLK
B	2-05-19	C-5) WIRE OB IS MOVED TO 4 FROM 5 OF P31; SEE SHEET 11 [C1193517]	SMH
C	3-18-19	SEE SHEETS 1 & 2 [C1194000]	SMH
D	2-13-19	SEE SHEETS 1 & 2 [C1195741]	TEV
E	9-10-19	SEE SHEET 2 [C1198508]	TEV

NOTE:
DASHED LINES ARE WIRES/COMPONENTS PROVIDED BY CUSTOMER
WHEN BREAKER IS REMOTE MOUNTED.

ELECTRICALLY OPERATED BREAKER OPTION
LOCAL GENERATOR MOUNTED BREAKER
APM603 CONTROLLER
80-300 KW JOHN DEERE TIER III
W/ SPLIT ACTIVATOR, 1#, 3# & 600V

APPROVALS		DATE	
DESIGNED BY	ABS	DATE	3-12-18
CHECKED BY	BTW	DATE	3-12-18
APPROVED BY	JLS	DATE	3-12-18

KOHLER	
MODEL NO.	80-300KW, APM603
DATE	10-11-18
DRAWING NO.	ADV-9057
REV	D

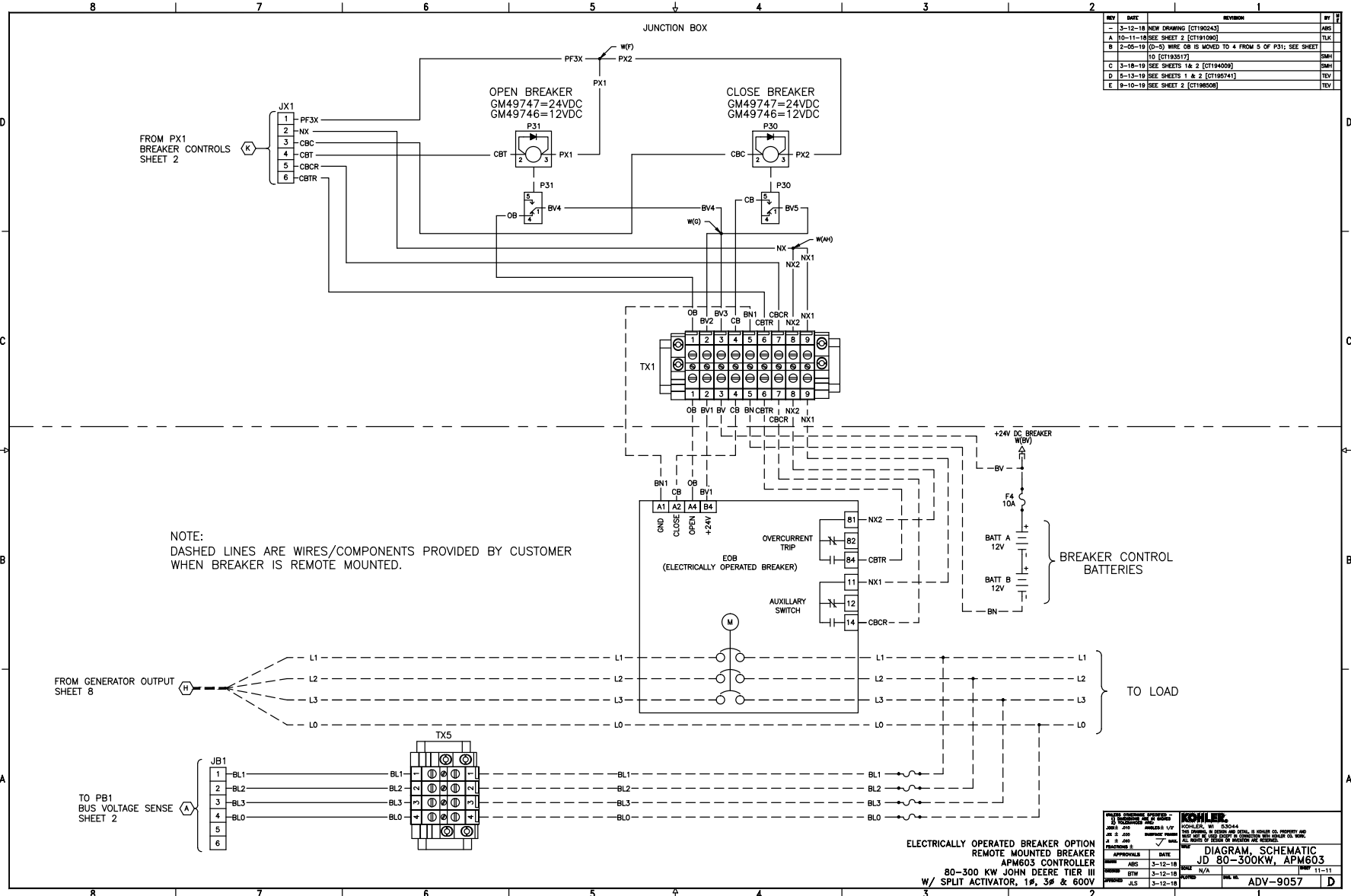

REV	DATE	REVISION	BY
1	3-12-18	NEW DRAWING [CT190243]	ABS
A	10-11-18	SEE SHEET 2 [CT191090]	TLX
B	2-05-19	(D-S) WIRE OB IS MOVED TO 4 FROM 5 OF P31; SEE SHEET 10 [CT193517]	SMY
C	3-18-19	SEE SHEETS 1 & 2 [CT194009]	SMY
D	2-13-19	SEE SHEETS 1 & 2 [CT190741]	TEV
E	9-10-19	SEE SHEET 2 [CT190508]	TEV

APPROVALS		DATE	
DESIGNED BY	JLS	DATE	3-12-18
CHECKED BY	ABS	DATE	3-12-18
APPROVED BY	JLS	DATE	3-12-18

KOHLER	
MODEL	80-300KW, APM603
DATE	3-12-18
REVISION	1.0
DESCRIPTION	DIAGRAM, SCHEMATIC
PROJECT	ADV-9057

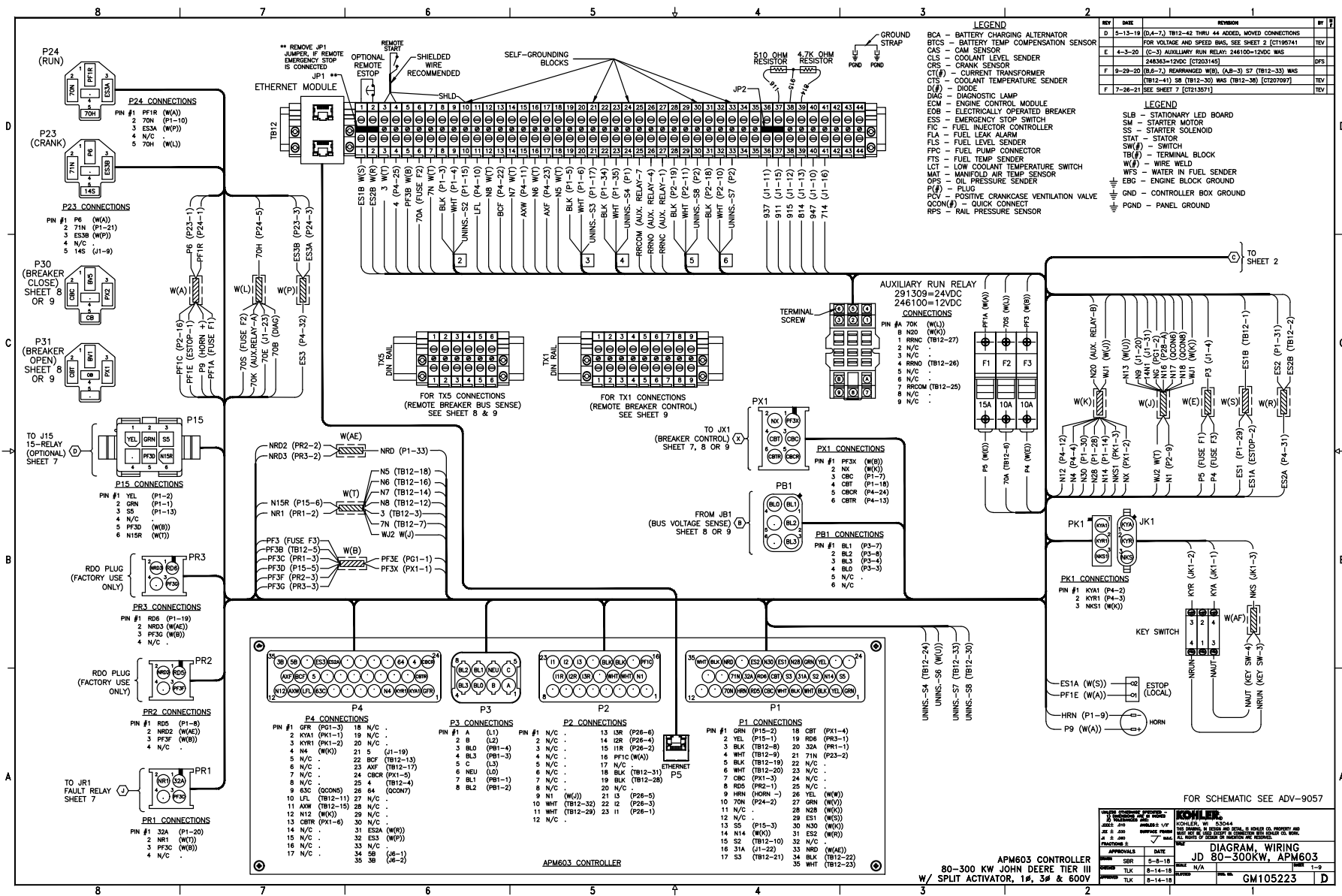

- LEGEND**
- BCA - BATTERY CHARGING ALTERNATOR
 - BTCs - BATTERY TEMP COMPENSATION SENSOR
 - CAS - CAM SENSOR
 - CLS - COOLANT LEVEL SENDER
 - CRS - CRANK SENSOR
 - CT(Φ) - CURRENT TRANSFORMER
 - CTS - COOLANT TEMPERATURE SENDER
 - D - DIODE
 - DLM - DIAGNOSTIC LAMP
 - EMC - ENGINE CONTROL MODULE
 - EDE - ELECTRICALLY OPERATED BREAKER
 - ESS - EMERGENCY STOP SWITCH
 - FI - FUEL INJECTOR CONTROLLER
 - FLA - FUEL LEAK ALARM
 - FLS - FUEL LEVEL SENDER
 - FPC - FUEL PUMP CONNECTOR
 - FTS - FUEL TEMP SENDER
 - LCT - LOW COOLANT TEMPERATURE SWITCH
 - MAT - MANIFOLD AIR TEMP SENSOR
 - OPS - OIL PRESSURE SENDER
 - PCV - POSITIVE CRANKCASE VENTILATION VALVE
 - QCON(Φ) - QUICK CONNECT
 - RPS - RAIL PRESSURE SENSOR

REV	DATE	REVISION	BY
D	5-13-19	(D-4-7) TB12-42 THRU 44 ADDED, MOVED CONNECTIONS	TEV
		FOR VOLTAGE AND SPEED BMS, SEE SHEET 2 [C1195741]	
E	4-3-20	(C-3) AUXILIARY RUN RELAY 246100=12VDC BMS 246385=12VDC [C203145]	DP3
F	9-29-20	(B-7) REWIRING WEL (A8-3) S7 (TB12-33) BMS (TB12-43) S8 (TB12-30) S9 (TB12-30) [C2027097]	TEV
F	7-26-21	SEE SHEET 7 [C1213571]	TEV

- LEGEND**
- SLB - STATIONARY LED BOARD
 - SM - STARTER MOTOR
 - SS - STARTER SOLENOID
 - STAT - STATOR
 - SW(Φ) - SWITCH
 - TB(Φ) - TERMINAL BLOCK
 - W(Φ) - WIRE WELD
 - WFS - WATER IN FUEL SENDER
 - EBG - ENGINE BLOCK GROUND
 - GND - CONTROLLER BOX GROUND
 - PGND - PANEL GROUND

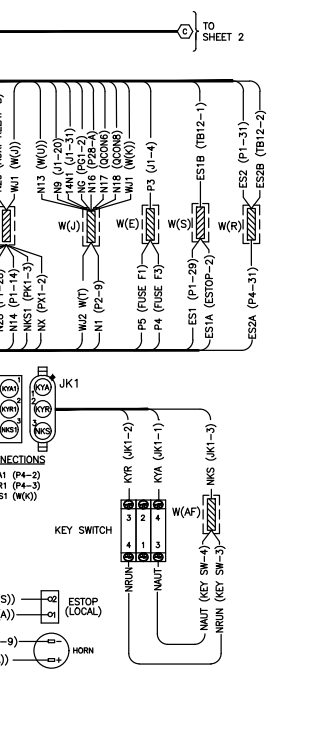

FOR SCHEMATIC SEE ADV-9057

APPROVALS	DATE	DIAGRAM, WIRING
DESIGNED BY: J.D.	5-8-18	JD 80-300KW, APM603
CHECKED BY: J.D.	8-14-18	
APPROVED BY: J.D.	8-14-18	
DATE: 8-14-18		GM105223

APM603 CONTROLLER
80-300 KW JOHN DEERE TIER III
W/ SPLIT ACTIVATOR, 1#, 3# & 600V

REV	DATE	REVISION	BY
C	3-18-19	SEE SHEETS 1 & 2 [C119400]	SMI
D	5-13-20	SEE SHEETS 1 & 2 [C1195741]	TEV
E	4-3-20	SEE SHEET 1 [C1203145]	DFS
F	9-29-20	SEE SHEET 1 [C1207097]	TEV
G	7-26-21	(B-1,2) TERMINATING RESISTOR KITS ADDED [C1213571]	TEV

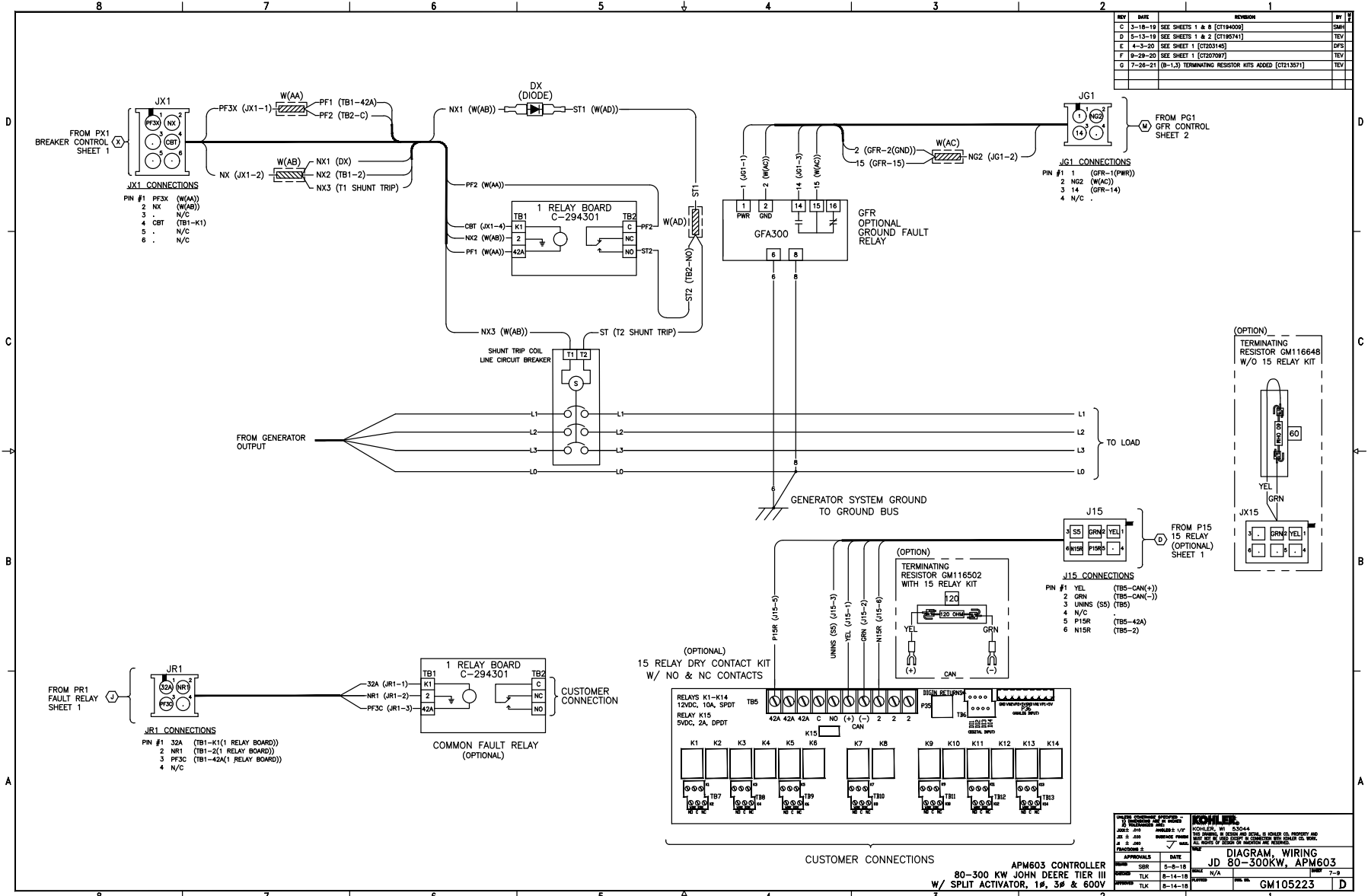

APPROVED BY	DATE	APPROVED BY	DATE
SMI	5-8-18	SMI	5-8-18
TEV	5-14-18	TEV	5-14-18
DFS	5-14-18	DFS	5-14-18

DIAGRAM, WIRING
JD 80-300KW, APM603
 GM105223

CUSTOMER CONNECTIONS

APM603 CONTROLLER
 80-300 KW JOHN DEERE TIER III
 W/ SPLIT ACTIVATOR, 1#, 3# & 600V

REV	DATE	REVISION	BY
C	3-18-19	(D-5) F4 ADDED SEE SHEET 1 [C1184009]	SMK
D	5-13-19	SEE SHEETS 1 & 2 [C1185741]	TEV
E	4-3-20	SEE SHEET 1 [C1203145]	WFS
F	9-29-20	SEE SHEET 1 [C1207097]	TEV
G	7-26-21	SEE SHEET 7 [C1215071]	TEV

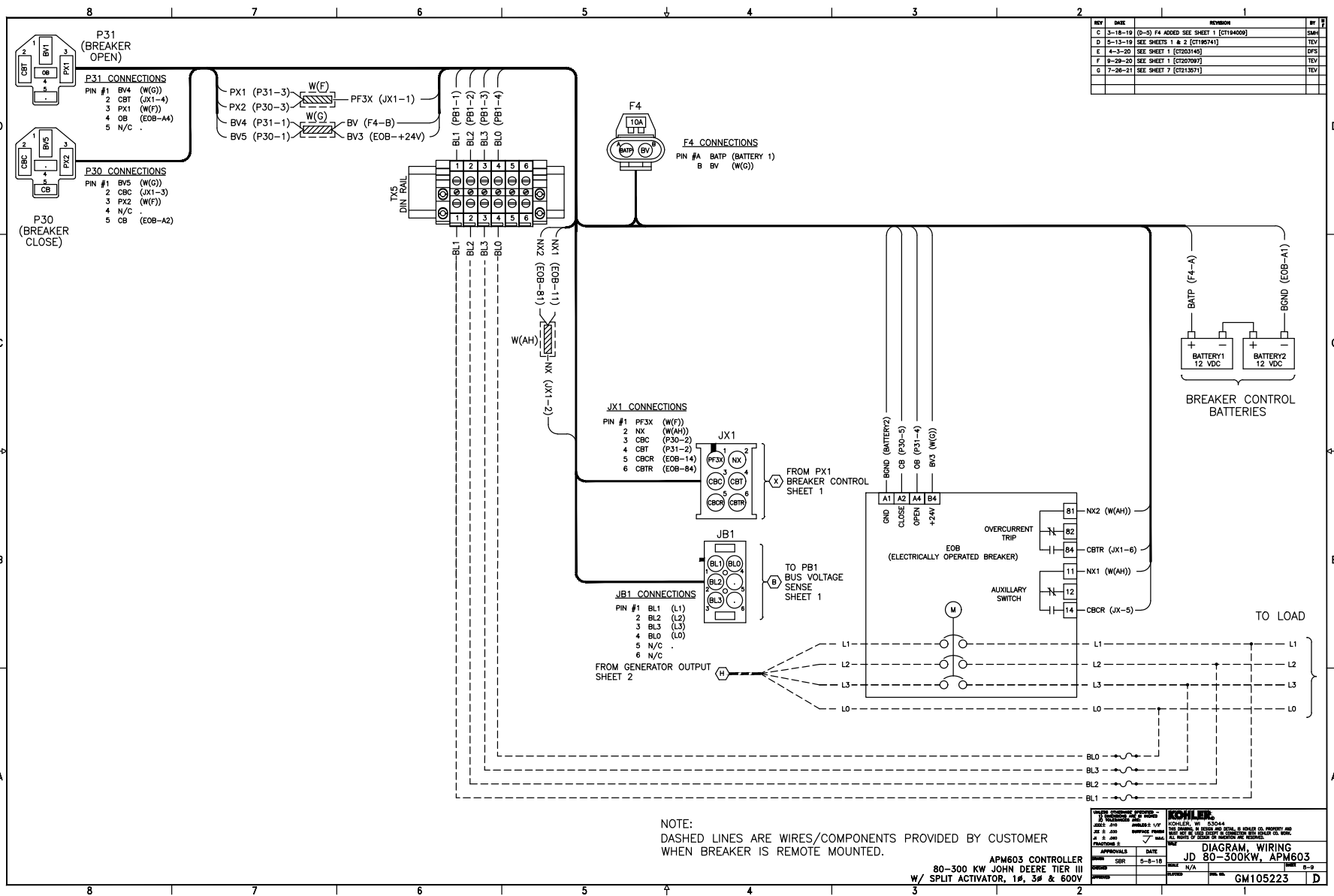

NOTE:
DASHED LINES ARE WIRES/COMPONENTS PROVIDED BY CUSTOMER
WHEN BREAKER IS REMOTE MOUNTED.

APM603 CONTROLLER
80-300 KW JOHN DEERE TIER III
W/ SPLIT ACTIVATOR, 1#, 3# & 600V

APPROVALS DATE 5-8-18	DATE N/A	KOHLER KOHLER, WI 53044 10000 W. WISCONSIN AVE. MILWAUKEE, WI 53044 TEL: 414.754.2000 FAX: 414.754.2001 WWW.KOHLER.COM	DIAGRAM WIRING JD 80-300KW, APM603 GM105223
-----------------------------	-------------	---	--

REV	DATE	REVISION	BY
C	3-18-19	SEE SHEETS 1 & 2 [C1194003]	SMK
D	5-13-19	SEE SHEETS 1 & 2 [C1195741]	TEV
E	4-3-20	SEE SHEET 1 [C1203145]	HFS
F	9-29-20	SEE SHEET 1 [C1207097]	TEV
G	7-26-21	SEE SHEET 7 [C1213571]	TEV

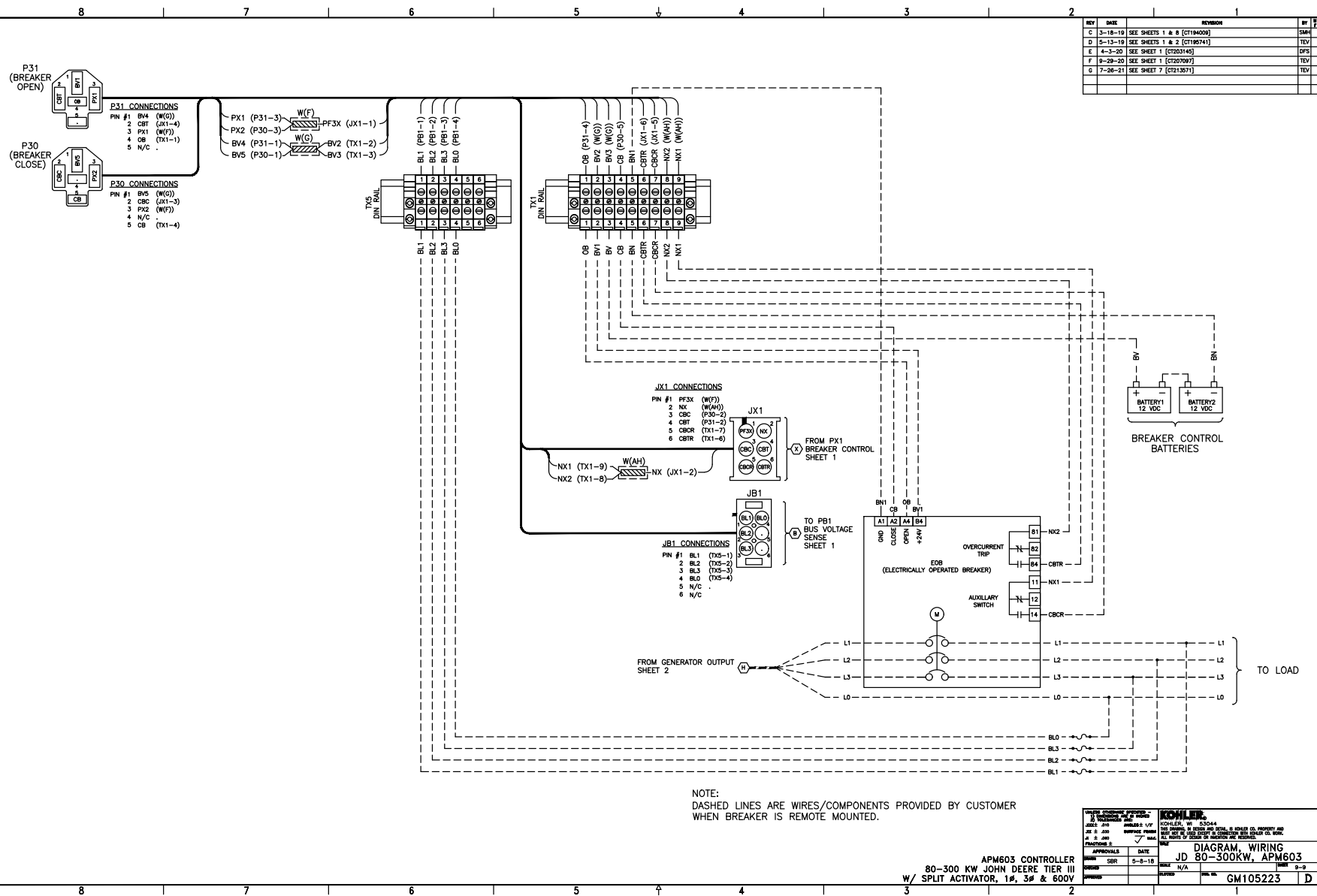

APM603 CONTROLLER
 80-300 KW JOHN DEERE TIER III
 W/ SPLIT ACTIVATOR, 1#, 3# & 600V

APPROVALS	DATE	REVISION	BY
DESIGN	5-8-18		SMK
CHECKED			
APPROVED			

KOHLER
 KOHLER, WI 53044
 SEE INSTRUCTIONS FOR WIRING
 SEE WIRING MANUAL FOR CONNECTIONS TO OTHER CO. EQUIP.
 ALL WIRING TO BE DONE IN ACCORDANCE WITH LOCAL CODES.

DIAGRAM WIRING
 JD 80-300KW, APM603
 SHEET 2-9
 GM105223

KOHLER®

Miscellaneous

OVERVIEW:
 THE AUTOMATIC MULTI-LEVEL FLOAT/ EQUALIZE CHARGER SPECIFIED BELOW IS INTENDED TO CHARGE ENGINE STARTING BATTERIES EITHER INDEPENDENT OR IN CONJUNCTION WITH AN ENGINE DRIVEN CHARGING SYSTEM.

BATTERY TYPES TO BE CHARGED:

- LEAD ACID
- AGM
- GEL CELL
- HIGH PERFORMANCE AGM
- FLOODED
- NICKEL CADMIUM (NiCd)

INPUT AC:

INPUT VOLTAGE: 90-265V SINGLE PHASE
 INPUT FREQUENCY: 47-63 Hz

INPUT LEAD:

APPROXIMATELY 1.8M (72") (REF) TYPE SJTOW -40°C TO 105°C UL RATED WIRE AND INSULATION. TERMINATED IN PRE-MOLDED UL RATED 3 PRONG NEMA 5-15 MALE AC PLUG.

DC OUTPUT:

10A @ 12V
 10A @ 24V
 VOLTAGE REGULATION: +/-1% (VOLTAGE AT EACH STAGE IS TOPOLOGY DEPENDENT)

OUTPUT LEAD:

APPROX. 1.8M (72") (REF) TYPE SJT00W -40°C TO 105°C UL RATED WIRE WITH RED AND BLACK WIRE INSULATION. TERMINATED IN 9.5 mm (REF) RING STYLE TERMINALS.

FUSES:

THE FUSE MUST BE LOCATED APPROXIMATELY 6" FROM RING TERMINAL ON RED OUTPUT LEAD.
 20A ATC

ENVIRONMENTAL:

STORAGE TEMPERATURE RANGE: -40 TO +85°C (-40 TO +185°F)
 OPERATING TEMPERATURE RANGE: -20 TO +70°C (-4 TO +158°F)
 HUMIDITY: 5 TO 95% (NON-CONDENSING)
 SALT SPRAY TESTING - ASTM B117
 CORROSION RESISTANT FROM GASSING OF BATTERIES

REVERSE POLARITY PROTECTION:

THE CHARGER SHALL SUSTAIN NO DAMAGE WHEN INCORRECTLY CONNECTED TO THE BATTERY IN REVERSE ORIENTATION.

MOUNTING:

4 NON-THREADED THROUGH HOLES FOR M6 FASTENERS TO PASS THROUGH

ENCLOSURE:

SHALL PROTECT THE CHARGER COMPONENTS FROM RAIN, SNOW, DUST AND DRIPPING WATER AND UNINTENTIONAL IMPACTS. ALL INTERNAL COMPONENTS PROTECTED FROM WATER DROPLETS.

INDICATORS:

POWER: INDICATES THE ACCEPTABILITY OF AC INPUT TO THE CHARGER
 COMMUNICATION: INDICATES THE STATE OF THE COMMUNICATION SYSTEM
 TEMPERATURE COMPENSATION: INDICATES THE STATE OF THE TEMPERATURE COMPENSATION SUBSYSTEM WHEN INSTALLED
 VOLTAGE OUTPUT: INDICATES THE STATE OF THE BATTERY AND CERTAIN FAULT CONDITIONS.

DOCUMENTATION:

THERE SHALL BE AN INSTALLATION / OPERATIONAL MANUAL SUPPLIED WITH EACH CHARGER. PER KOHLER SUPPLIED ARTWORK.

CERTIFICATIONS (US AND CANADA):

- UL1236
- CSA - C22.2 NO 107.2-01
- FCC- TITLE 47, PART 15 CLASS A
- CE
- EN 61000-6-2
- CEC AND DOE
- NFPA-110 LEVEL 1 (WHEN SUPPORTED WITH APPLICABLE KOHLER CONTROLLER)
- IBC

PRODUCT LABELING:

THE LABEL ATTACHED TO THE CHARGER SHALL HAVE THE FOLLOWING INFORMATION:
 UL LISTING
 KOHLER PART NUMBER
 DESCRIPTION OF ALL INDICATOR
 OUTPUT CURRENT AND VOLTAGE
 INPUT VOLTAGE AND FREQUENCY

PACKAGING LABEL:
 THE PACKAGING LABEL SHALL CONTAIN THE FOLLOWING INFORMATION:
 KOHLER P/N
 DESCRIPTION - BATTERY CHARGER
 MFG. MODEL NO
 MFG. PART NUMBER
 DATE CODE

WARRANTY:
 2 YEAR FROM DATE OF PURCHASE FROM MANUFACTURE.

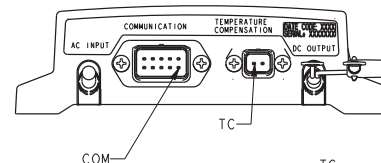
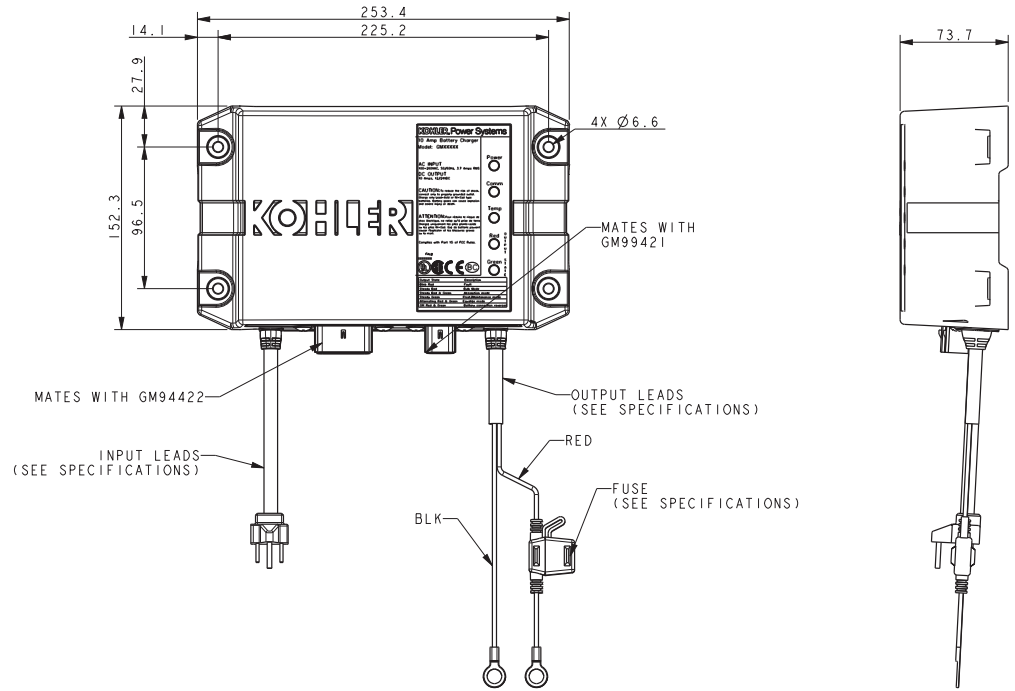

- COM PIN 1 N/C
 2 ID SEL 1
 3 ID SEL 2
 4 N/C
 5 CAN-H
 6 N/C
 7 ID SEL 1 RTN
 8 ID SEL 2 RTN
 9 CAN-GND
 10 CAN-L
- I.C. PIN 1 TC SENSOR W1
 2 TC SENSOR W2

REV	DATE	ON COMPOSITE DWGS. SEE PART NO. FOR REVISION LEVEL	BY	UNLESS OTHERWISE SPECIFIED: 1) DIMENSIONS ARE IN MILLIMETERS 2) TOLERANCES ARE: X .XX ± 0.25 Z .X ± 1.5 SURFACE FINISH ANGLES ± 0° 30' MAX.	TITLE
-	9-22-14	NEW DRAWING [CT91634]	SAM		KOHLER CO. METRIC PRO-E
A	5-9-17	(C-4, 2) MATING NOTE ADDED (A-2, 4) PIN CONNECTIONS ADDED [CT174256]	SAM		POWER SYSTEMS, KOHLER, WI 53044 U.S.A. THIS DRAWING IN DESIGN AND DETAIL IS KOHLER CO. PROPERTY AND MUST NOT BE USED EXCEPT IN CONNECTION WITH KOHLER CO. WORK. ALL RIGHTS OF DESIGN OR INVENTION ARE RESERVED.
					CHARGER, BATTERY 10 AMP
					SCALE 0.50 CAD NO. SHEET 1 of 1
					DWG NO. GM87448 D

KIT NO.	ITEM	PART NO	QTY	DESCRIPTION
GMI03743				E-STOP, NEC REMOTE
	1	GMI03743-1	1	E-STOP W/ YELLOW SHROUD, LOTO
	2	GMI03743-2	4	#10 X 1.25 Sheetmetal Screw
	3	GMI03743-3	1	TERMINAL, FAST-ON, MALE, 18-22 AWG
	4	GMI03743-4	1	TERMINAL, FAST-ON, FEMALE, 18-22 AWG
	5	GMI03743-5	2	TERMINAL, SPADE, 22-16 AWG
	6	GMI03743-6	1	LITERATURE, TT-1736

THIS IS AN AUTOMATED TABLE. ALL UPDATES MUST BE MADE IN THE ASSEMBLY.

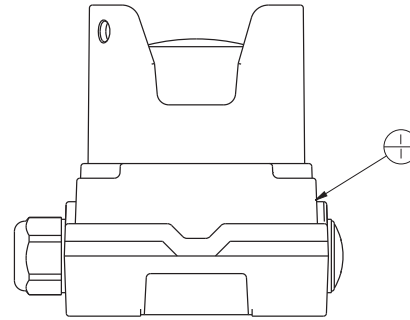
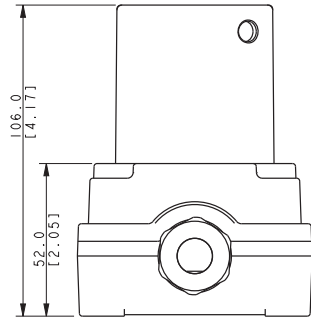
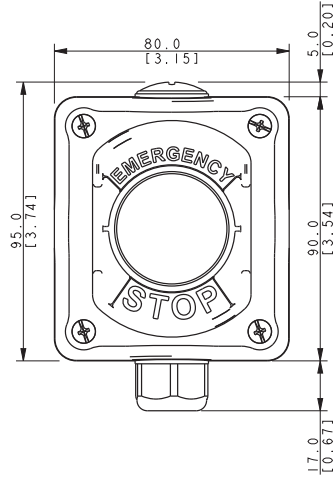

SCALE 1.50

NOTE:
DIMENSIONS IN [] ARE IN INCH EQUIVALENTS.
SCREWS AND TERMINALS ARE TO BE BAGGED
AND PLACED IN THE BOX

REV	DATE	ON COMPOSITE DWGS. SEE PART NO. FOR REVISION LEVEL	BY	UNLESS OTHERWISE SPECIFIED: 1) DIMENSIONS ARE IN MILLIMETERS 2) TOLERANCES ARE: X .XX ± 0.25 Y .Y ± 0.5 Z .Z ± 1.5 SURFACE FINISH ANGLES ± 0° 30' MAX.	TITLES
-	2-12-18	NEW DRAWING [CT176728]	CCL		KOHLER CO. METRIC PRO-E
					POWER SYSTEMS, KOHLER, WI 53044 U.S.A.
					THIS DRAWING IN DESIGN AND DETAIL IS KOHLER CO. PROPERTY AND MUST NOT BE USED EXCEPT IN CONNECTION WITH KOHLER CO. WORK. ALL RIGHTS OF DESIGN OR INVENTION ARE RESERVED.
					TITLE
					E-STOP, NEC REMOTE
					SCALE 1.50 CAD NO.
					DWG NO. GMI03743 SHEET 1 of 1
					APPROVED KJB 2-12-18
					APPROVED KJB 2-12-18

KOHLER®

Warranty

Stationary Standby and Prime Power Industrial Generator Set One-Year or Two Thousand (2000)-Hour Limited Warranty

Your Kohler product has been manufactured and inspected with care by experienced craftsmen. If you are the original end user, Kohler Co. warrants, for the period indicated below, each product to be free from defects in materials and workmanship. In the event of a defect in materials or workmanship, Kohler Co. will repair, replace, or make appropriate adjustment at Kohler Co.'s option if the product, upon Kohler Co.'s inspection, is found to be properly installed, maintained, and operated in accordance with Kohler Co.'s instruction manuals. A Kohler distributor, dealer, or authorized service representative must perform startup.

Kohler Product

Stationary Standby Generator Set & Accessories

Warranty Coverage

One (1) year from registered startup or two thousand (2000) hours (whichever occurs first). In any event, the warranty period will expire not later than thirty (30) months from the date of shipment from Kohler Co.'s factory.

Stationary Prime Power Generator Set & Accessories

One (1) year from registered startup or two thousand (2000) hours (whichever occurs first). In any event, the warranty period will expire not later than thirty (30) months from the date of shipment from Kohler Co.'s factory.

The following will **not** be covered by the warranty:

1. Normal wear, routine tuneups, tuneup parts, adjustments, and periodic service.
2. Damage, including but not limited to damage caused by accidents, improper installation or handling, faulty repairs not performed by an authorized Kohler service representative, improper storage, or acts of God.
3. Damage caused by operation at speeds, or with fuel, loads, conditions, modifications or installation contrary to published specifications.
4. Damage caused by negligent maintenance such as:
 - a. Failure to provide the specified type and sufficient quantity of lubricating oil.
 - b. Failure to keep the air intake and cooling fin areas clean.
 - c. Failure to service the air cleaner.
 - d. Failure to provide sufficient coolant and/or cooling air.
 - e. Failure to perform scheduled maintenance as prescribed in supplied manuals.
 - f. Failure to regularly exercise the generator set under load (stationary applications only).
5. Original installation charges and startup costs.
6. Starting batteries and the following related expenses:
 - a. Labor charges related to battery service.
 - b. Travel expenses related to battery service.
7. Additional expenses for repairs performed after normal business hours, i.e. overtime or holiday labor rates.
8. Rental of equipment during the performance of warranty repairs.
9. Removal and replacement of non-Kohler-supplied options and equipment.
10. Non-Kohler replacement parts. Replacement of a failed Kohler part with a non-Kohler part voids the warranty on that part.
11. Radiators replaced rather than repaired.
12. Fuel injection pumps not repaired by an authorized Kohler service representative.
13. Non-Kohler-authorized repair shop labor without prior approval from Kohler Co. Warranty Department.
14. Engine fluids such as fuel, oil, or coolant/antifreeze.
15. Shop supplies such as adhesives, cleaning solvents, and rags.
16. Expenses incurred investigating performance complaints unless the problem is caused by defective Kohler materials or workmanship.
17. Maintenance items such as fuses, lamps, filters, spark plugs, loose or leaking clamps, and adjustments.
18. Travel time and mileage exceeding 300 miles round trip.

To obtain warranty service, call 1-800-544-2444 for your nearest authorized Kohler service representative or write Kohler Co., Service Department, MS072, Kohler, WI 53044 USA.

KOHLER CO. SHALL NOT BE LIABLE FOR SPECIAL, INCIDENTAL, AND/OR CONSEQUENTIAL DAMAGES OF ANY KIND including, but not limited to, incidental and/or consequential labor costs, installation charges, telephone charges, or transportation charges in connection with the replacement or repair of defective parts.

This is our exclusive written warranty. We make no other express warranty nor is anyone authorized to make any on our behalf.

ANY IMPLIED OR STATUTORY WARRANTY, INCLUDING ANY WARRANTY OF MERCHANTABILITY OR FITNESS FOR A PARTICULAR PURPOSE, IS EXPRESSLY LIMITED TO THE DURATION OF THIS WARRANTY. Some states do not allow limitations on how long an implied warranty lasts, or the exclusion or limitation of incidental and/or consequential damages, so the above limitation or exclusion may not apply to you.

This warranty gives you specific legal rights, and you may also have other rights which vary from state to state.

KOHLER®

KOHLER CO., Kohler, Wisconsin 53044
Phone 920-457-4441, Fax 920-459-1646
For the nearest sales/service outlet in the US and Canada, phone 1-800-544-2444
KOHLERPower.com

TP-5374 12/15f

KOHLER®

Certification



CERTIFICATE OF COMPLIANCE
SEISMIC DESIGN OF NONSTRUCTURAL COMPONENTS AND SYSTEMS



Certification No.

VMA-53731-01C (Revision 0)

Expiration Date: 7/31/2023

Certification Parameters:

The nonstructural products (mechanical and/or electrical components) listed on this certificate are CERTIFIED¹ FOR SEISMIC APPLICATIONS in accordance with the following building code² releases.

IBC 2018, 2015, 2012, 2009

The following model designations, options, and accessories are included in this certification. Reference report number VMA-53731-01 as issued by The VMC Group for a complete list of certified models, included accessories/options, and certified installation methods.

**Kohler; Diesel Gensets
REOZJx; 80-500 kW**

The above referenced equipment is APPROVED for seismic application when properly installed³, used as intended, and contains a Seismic Certification Label referencing this Certificate of Compliance⁴. As limited by the tabulated values, below grade, grade, and roof-level installations, installations in essential facilities, for life safety applications, and/or of equipment containing hazardous contents are permitted and included in this certification with an Equipment Importance Factor assigned as $I_p=1.5$. The equipment is qualified by successful seismic shake table testing at the nationally recognized University of California Berkeley Pacific Earthquake Engineering Research Center under the witness of the ISO Accredited Product Certification Agency, the VMC Group.

Certified Seismic Design Levels			
Certified IBC	Importance $I_p \leq 1.5$ Soil Classes A-E Risk Categories I-IV Design Categories A-F	$z/h \leq 1.0$	$z/h = 0.0$
		$S_{DS} \leq 2.000\text{ g}$	$S_{DS} \leq 2.000\text{ g}$

Certified Seismic Installation Methods	
Rigid Mounting From Fuel Tank To Rigid Structure	Rigid Mounting From Unit Base To Rigid Structure
Rigid Mounting From Unit Base To Fuel Tank	

HEADQUARTERS
113 Main Street
Bloomington, NJ 07403
Phone: 973.838.1780
Toll Free: 800.569.8423
Fax: 973.492.8430

CALIFORNIA
180 Promenade Circle
Suite 300
Sacramento, CA 95834
Phone: 916.634.7771

TEXAS
11930 Brittmoore Park Drive
Houston, TX 77041
Phone: 713.466.0003
Fax: 713.466.1355

thevmcgroup.com





CERTIFICATE OF COMPLIANCE
SEISMIC DESIGN OF NONSTRUCTURAL COMPONENTS AND SYSTEMS

Certified Product Table:

Model	Max Rating [kW]	Max Length [in.]	Max Width [in.]	Max Height [in.]	Max Weight [lbs.]		
80REOZJF	80	142	72	107	12233		
100REOZJF	100	175		111	12850		
125REOZJG	125				15919		
150REOZJF	150	214		123	18636		
180REOZJG	180		19162				
200REOZJF	200	210	53	121	16297		
230REOZJE	230				16397		
250REOZJG	250				16697		
275REOZJE	275				18000		
300REOZJ	300	220	52	116	18000		
350REOZJC	350	272	102	137	37279		
350REOZJD						41196	
400REOZJC	400	286			116	137	41196
400REOZJD							
500REOZJC	500	327			43800		

Maximum available dimensions and weights are shown.
For available Enclosed/Open and On Tank/Off Tank Options/Limits please contact the manufacturer

Type	S _{DS} (z/h=0)	S _{DS} (z/h=1)	A _{FLEX-H}	A _{RIG-H}	A _{FLEX-V}	A _{RIG-V}	F _p /W _p
AC156	2.00	2.00	3.20	2.40	1.34	0.54	1.50

This certification includes REOZJx Diesel Gensets and included factory supplied options. This certification only covers accessories and options directly mounted to the Gensets. The Genset and applicable options shall be installed per the manufacturer supplied seismic installation instructions. For a list of certified configurations and options please directly contact the manufacturer. This certification excludes all non-factory supplied accessories and options, including but not limited to isolation/restraint devices, other electrical/mechanical components and all connections for electrical, fuel, heating or cooling fluid, or other pipe/conduit connections and configurations not detailed in the above charts. Flexibility in the connections must be maintained as to not transmit load into the equipment. Design specials are outside the scope of this certification.



VMA-53731-01C (Revision 0)
Issue Date: Friday, August 14, 2020
Revision Date: Friday, August 14, 2020
Expiration Date: Monday, July 31, 2023



CERTIFICATE OF COMPLIANCE

SEISMIC DESIGN OF NONSTRUCTURAL COMPONENTS AND SYSTEMS

Notes & Comments:

1. All equipment listed herein successfully passed the seismic acceptance criteria for shake testing non-structural components and systems as set forth in the ICC AC-156. The Test Response Spectrum (TRS) enveloped the Required Response Spectrum (RRS) for all units tested. The units cited in this certification were representative sample(s) of a contingent of models and all remained captive and structurally sound after the seismic shake simulation. The units also remained functionally operational after the simulation testing as functional testing was completed by the equipment manufacturer before and after the seismic simulations. Although a seismic qualified unit inherently contains some wind resisting capacity, that capacity is undetermined and is excluded from this certification. Snow/Ice loads have been neglected and thus limit the unit to be installed both indoors (covered by an independent protective structure) and out of doors (exposed to accumulating snow/ice) for ground snow loads no greater than 30 psf for all applications.
2. The following building codes are addressed under this certification:
 - IBC 2018 referencing ASCE7-16 and ICC-ES AC-156
 - IBC 2015 referencing ASCE7-10 and ICC-ES AC-156
 - IBC 2012 referencing ASCE7-10 and ICC-ES AC-156
 - IBC 2009 referencing ASCE7-05 and ICC-ES AC-156
3. Refer to the manufacturer supplied installation drawings for anchor requirements and mounting considerations for seismic applications. Required anchor locations, size, style, and load capacities (tension and shear) may be specified on the installation drawings or specified by a 3rd party. Mounting requirement details such as anchor brand, type, embedment depth, edge spacing, anchor-to-anchor spacing, concrete strength, special inspection, wall design, and attachment to non-building structures must be outlined and approved by the Engineer of Record for the project or building. Structural walls, structural floors, and housekeeping pads must also be seismically designed and approved by the project or building Structural Engineer of Record to withstand the seismic anchor loads as defined on the installation drawings. The installing contractor is responsible for ensuring the proper installation of all anchors and mounting hardware.
4. For this certificate and certification to remain valid, this certificate must correspond to the "Seismic Certification Label" found affixed to the unit by the factory. The label ensures the manufacturer built the unit in conformance to the IBC seismic design criteria set forth by the Certified Seismic Qualification Agency, the VMC Group, and meets the seismic design levels claimed by this certificate.
5. Mechanical, Electrical, and Plumbing connections to the equipment must be flexibly attached as to not transfer load through the connection. The structural integrity of any conduit, cable trays, piping, ductwork and/or flexible connections is the responsibility of others. This certification does not guarantee the equipment will remain compliant to NEMA, IP, UL, or CSA standards after a seismic event.
6. This certificate applies to units manufactured at:
 - Kohler, N7650 Lakeshore Road, Sheboygan, WI 53083
7. This certification follows the VMC Group's ISO-17065 Scheme.

John P. Giuliano, PE
President, VMC Group



VMA-53731-01C (Revision 0)
Issue Date: Friday, August 14, 2020
Revision Date: Friday, August 14, 2020
Expiration Date: Monday, July 31, 2023



Certificate of Registration

QUALITY MANAGEMENT SYSTEM - ISO 9001:2015

This is to certify that:

Kohler Power Systems
N7650 Lakeshore Road
Sheboygan
Wisconsin
53083
USA

Holds Certificate No:

FM 727336

and operates a Quality Management System which complies with the requirements of ISO 9001:2015 for the following scope:

Design, manufacture, and distributor support for electrical generators, alternators, fuel tanks, automatic transfer switches and switchgear.

For and on behalf of BSI:



Carlos Pitanga, Chief Operating Officer Assurance – Americas

Original Registration Date: 1995-02-28

Latest Revision Date: 2021-10-29

Effective Date: 2021-11-07

Expiry Date: 2024-11-06

Page: 1 of 2



...making excellence a habit.™

Certificate No: **FM 727336**

Location	Registered Activities
Kohler Power Systems - GK 900 Highland Drive Bldg 604 Kohler Wisconsin 53004 USA	Manufacture of leads and harness, automatic transfer switches and switchgear. Distribution of generator sets.
Kohler Power Systems N7650 Lakeshore Road Sheboygan Wisconsin 53083 USA	Design, manufacture, and distributor support for electrical generators, automatic transfer switches and switchgear.
Kohler Power Systems 300 N Dekora Woods Blvd Saukville Wisconsin 53080 USA	Manufacture of fuel tanks, skids, fabricated components and generators.
Kohler Power Systems Muth Warehouse 2821 Muth Court Sheboygan Wisconsin 53083 USA	The distribution of generator sets.
Kohler Power Systems KWIP Warehouse 4327 County EE Sheboygan Wisconsin 53081 USA	Receiving, sequencing and warehousing of generator components.

Original Registration Date: 1995-02-28

Latest Revision Date: 2021-10-29

Effective Date: 2021-11-07

Expiry Date: 2024-11-06

Page: 2 of 2

This certificate remains the property of BSI and shall be returned immediately upon request.

An electronic certificate can be authenticated [online](https://www.bsigroup.com/ClientDirectory). Printed copies can be validated at www.bsigroup.com/ClientDirectory
To be read in conjunction with the scope above or the attached appendix.

Information and Contact: BSI, Kitemark Court, Davy Avenue, Knowlhill, Milton Keynes MK5 8PR. Tel: + 44 345 080 9000
BSI Assurance UK Limited, registered in England under number 7805321 at 389 Chiswick High Road, London W4 4AL, UK.
A Member of the BSI Group of Companies.

G15-152 10/21

PROTOTYPE TEST REPORT



Models Covered: **300REOZJ**
Model Tested: **300REOZJ**
Cooling System Tested: **50C**

Alternator Tested: **4UA13**
Engine Tested: **6090HFG86**
Voltage Tested: **208V**

GENSET

Maximum power test to assure that the prime mover and alternator have sufficient capacity to operate within specifications.

Meets Rated Load

Steady-state load test to ensure voltage stability meets or exceeds ISO8528-5 requirements and to verify compliance with steady state speed control specifications.

± 0.25 % Frequency Band

± 0.50 % Voltage Deviation

Transient load tests per NEMA MG1-32.18, and ISO 8528 to verify specifications of transient voltage regulation, voltage dip, voltage overshoot, recovery voltage, and recovery time. Values shown for model tested above. Please contact factory for additional details.

Full Load Acceptance

35.7 % Voltage Dip

2.30 Seconds of Recovery Time

15.6 % Frequency Dip

6.20 Seconds of Recovery Time

Full Load Rejection

12.5 % Voltage Overshoot

0.60 Seconds of Recovery Time

4.40 % Frequency Overshoot

0.70 Seconds of Recovery Time

G3 ISO8528-5 Class (G1, G2, G3)

NFPA 110 one step testing to determine the amount of time required for the generator set to reach 90% voltage and frequency to allow the ATS to transfer.

Complies with NFPA 110 Type 10

Vibrational analysis to verify that generator vibrations are within acceptable limits per ISO 8528-9.

Complies

Torsional analysis data to verify torsional effects are not detrimental and that the generator set will provide dependable service as specified.

Complies

Generator set cooling and air flow tests to verify maximum operating ambient temperature. (Cooling system test results are available on TIB-118)

Acoustical noise intensity and sound attenuation effects tests (Acoustical noise results are available on TIB-114 & 115)

Exhaust Back Pressure test completed to demonstrate within engine limitation (Exhaust back pressure test results are available on TIB-119)

PROTOTYPE TEST REPORT



Models Covered: **300REOZJ**
Model Tested: **300REOZJ**
Cooling System Tested: **50C**

Alternator Tested: **4UA13**
Engine Tested: **6090HFG86**
Voltage Tested: **208V**

ALTERNATOR

Alternator temperature rise test per NEMA MG1-32.6. Standby and prime ratings of the alternator are established during this test.

Alternator overload test per NEMA MG1-32.8. Motor starting tests per NEMA MG1-32.18.5 to evaluate capabilities of generator, exciter, and regulator system.

Three-phase symmetrical short-circuit test per NEMA MG1-32.13 to demonstrate short circuit performance, mechanical integrity, ability to sustain short-circuit current.

Harmonic analysis, voltage waveform deviation per NEMA MG1-32.10 to confirm that the generator set is producing clean voltage within acceptable limits.

(Alternator detailed test results are available on TIB-102)

Kohler Standby/Prime Generator Set Test Program

Testing is an integral part of quality assurance. In keeping with our uncompromising commitment to quality, safety, and reliability, every Kohler Standby/Prime power generator set undergoes an extensive series of prototype and production testing.

Prototype Testing

Prototype testing includes the potentially destructive tests necessary to verify design, proper function of protective devices and safety features, and reliability expectations. Kohler's prototype testing includes the following:

- Alternator temperature rise test per NEMA MG1-32.6. Standby and prime ratings of the alternator are established during this test.
- Maximum power test to assure that the prime mover and alternator have sufficient capacity to operate within specifications.
- Alternator overload test per NEMA MG1-32.8.
- Steady-state load test to ensure voltage regulation meets or exceeds ANSI C84.1, NEMA MG1-32.17 requirements and to verify compliance with steady-state speed control specifications.
- Transient test to verify speed controls meets or exceeds specifications.
- Transient load tests per NEMA MG1-32.18, and ISO 8528 to verify specifications of transient voltage regulation, voltage dip, voltage overshoot, recovery voltage, and recovery time.
- Motor starting tests per NEMA MG1-32.18.5 to evaluate capabilities of generator, exciter, and regulator system.
- Three-phase symmetrical short-circuit test per NEMA MG1-32.13 to demonstrate short circuit performance, mechanical integrity, ability to sustain short-circuit current.
- Harmonic analysis, voltage waveform deviation per NEMA MG1-32.10 to confirm that the generator set is producing clean voltage within acceptable limits.

Torsional analysis data, to verify torsional effects are not detrimental and that the generator set will provide dependable service as specified, is available upon request.

Kohler offers other testing at the customer's request at an additional charge. These optional tests include power factor testing, customized load testing for specific application, witness testing, and a broad range of MIL-STD-705c testing. A certified test report is also available at an additional charge.

- Generator set cooling and air flow tests to verify maximum operating ambient temperature.
- Reliability tests to demonstrate product durability, followed by root cause analysis of discovered failures and defects. Corrective action is taken to improve the design, workmanship, or components.
- Acoustical noise intensity and sound attenuation effects tests.

Production Testing

In production, Kohler Standby/Prime generator sets are built to the stringent standards established by the prototype program. Every Kohler generator set is fully tested prior to leaving the factory. Production testing includes the following:

- Stator and exciter winding high-potential test on all generators. Surge transient tests on stators for generators 180 kW or larger. Continuity and balance tests on all rotors.
- One-step, full-load pickup tests to verify that the performance of each generator set, regulator, and governor meets published specifications.
- Regulation and stability of voltage and frequency are tested and verified at no load, 1/4 load, 1/2 load, 3/4 load, and full-rated load.
- Voltage, amperage, frequency and power output ratings verified by full-load test.
- The proper operation of controller logic circuitry, prealarm warnings, and shutdown functions is tested and verified.
- Any defect or variation from specification discovered during testing is corrected and retested prior to approval for shipment to the customer.

KOHLER[®]

KOHLER CO. Kohler, Wisconsin 53044
Phone 920-565-3381, Fax 920-459-1646
For the nearest sales/service outlet in the
US and Canada, phone 1-800-544-2444
KohlerPowerSystems.com