

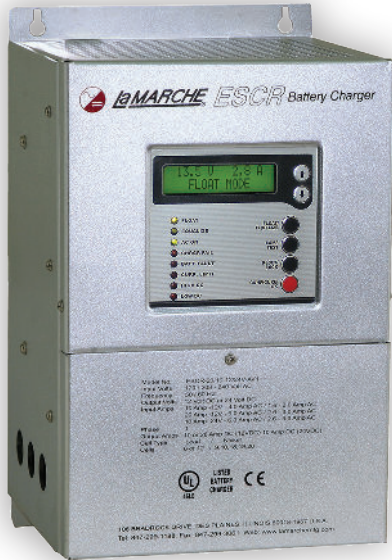

ESCR Engine Starting Applications



Unit Shown: ESCR-20/10-12/24V-AV1



The ESCR engine starting battery charger product line utilizes microprocessor controlled SCR Charging Technology. The PWM control provides the highest reliability that is required for maintaining and recharging engine start batteries for generator sets. This charger is suitable for various types of batteries such as flooded lead acid, VRLA and NiCad.

Automatic Input sensing for 120/208-240 VAC 50/60Hz does not require any tap changes and multi-output (12V/24V) makes this product line flexible and convenient for multiple jobs. The 0.5% regulation, temperature compensation, battery check, equalize timer along with adjustable output voltage and current limiting assures longevity and performance for your batteries. This economical solution equipped with advanced features incorporates La Marche quality and reliability.

The front panel is equipped with LCD display, alarm status LED's and controls. The two-line LCD displays output voltage and current along with alarm status text description. Individual LED indicators provide local supervision.

Form "C" contacts are available for remote annunciation. Push button controls are used for Float/Equalize mode, Reset, Lamp Test and Configure. This multi-input/output all-in-one unit meets NFPA 110, C62.41A and UL safety requirements. It is also certified for seismic applications in accordance with International Building Code (IBC) & OSHPD / California Building Code.

Standard Features

- Microprocessor Controlled SCR Technology
- Auto Select Input 120/208-240 VAC, 50/60Hz
- Field Selectable Output 12/24 VDC (Select Models)
- Available Output Ranges 6-40 Amps
- LCD Display
- Alarm LED's and Form "C" Contacts
- Adjustable Float and Equalize Voltages
- Automatic AC Input Voltage Compensation
- AC to DC Isolation
- Filtering Suitable for VRLA Batteries
- Battery Fault Detection
- Internal Temperature Compensation
- Multimode Equalize Timer
- Powder Coated Aluminum Enclosure
- Soft Start
- Adjustable Current Limiting

- Meets NFPA 110 and C62.41A
- UL 1236 Listed
- CE Certified
- IBC Certified for seismic applications
- OSHPD Certified
- ABS Approved
- 3 Year Warranty

Optional Accessories

- 080** Drip Shield
- 09P** Conformal Coated Circuit Boards
- 101** 3 Battery Charge Divider - Negative Common
- 11W** External Temperature Compensation Probe
- 18L** Output Disconnect Relay
- 530** CUL Listing
- 38H** ABS Certified Report
- 316** Battery Test (only available for single voltage units)



| Model Number | DC Output | | AC Input | | Overall Dimensions W x D x H | Case No. | Shipping Weight | |
|-----------------------|-----------------|----------------|-----------------|-------------------------------|--|----------|-----------------|-----|
| | Volts (Nominal) | Amps | Volts (Nominal) | Amps | | | lbs | kgs |
| ESCR-6-12/24V-AV1* | 12 24 | 6 | 120/208-240 | 3.0/1.5 | 6.4" x 7" x 9.35" 162 x 179 x 237mm | 100 | 16 | 7 |
| ESCR-10-24V-AV1 | 24 | 10 | 120/208-240 | 6.0/3.0 | 7.75" x 7" x 11.25" 197 x 179 x 285mm | 98 | 25 | 11 |
| ESCR-20/10-12/24V-AV1 | 12 12 24 | 10 20 10 | 120/208-240 | 3.2/1.6 5.4/3.0 6.0/3.0 | 7.75" x 7" x 11.25" 197 x 179 x 285mm | 98 | 25 | 11 |
| ESCR-20-24V-AV1 | 24 | 20 | 120/208-240 | 12.1/6.1 | 11.38" x 9" x 15" 289 x 229 x 381mm | 99 | 42 | 19 |
| ESCR-40/20-12/24V-AV1 | 12 24 | 40 20 | 120/208-240 | 10.9/5.9 12.1/6.1 | 11.38" x 9" x 15" 289 x 229 x 381mm | 99 | 42 | 19 |

* Not IBC or OSHPD Certified

AC INPUT

- 120/208 - 240 VAC $\pm 10\%$, 50/60HZ, Single Phase

DC OUTPUT (Field Selectable)

- 6A @ 12V or 6A @ 24V
- 10A @ 12V or 20A @ 12V or 10A @ 24V
- 40A @ 12V or 20A @ 24V

REGULATION

- **Line:** $< \pm 0.5\%$
- **Load:** $< \pm 0.5\%$

OUTPUT FILTERING

(W/ Battery Connected)

- **< 500 mV RMS**

PROTECTION

- **Input**
Fuse with Surge Protection
- **Output**
Fuse with Surge Protection
Reverse Polarity Protection

BATTERY CELL SELECTION

- **12 Volts**
6L
9NC
10NC
- **24 Volts**
12L
18NC
19NC
20NC

OUTPUT CURRENT LIMIT

- Factory set at 105%
Adjustable from 50 - 105%

METERING

- LCD DC Output Digital Voltmeter and Ammeter (1%)

ADJUSTABLE VOLTAGE RANGE

- **Float Voltage**
2.12 - 2.3 volts/cell (Lead)
1.39 - 1.45 volts/cell (NiCad)
- **Equalize Voltage**
2.25 - 2.40 volts/cell (Lead)
1.45 - 1.6 volts/cell (NiCad)

CONTROLS

- **Float and Equalize Button**
Switch from Float to Equalize
- **Configure Button**
Output Settings
Voltage and Cells
Adjust Voltage for Float & Equalize
Adjust Alarm Settings and Delay
Enable/Disable Temperature Compensation
Equalize Timer
~ Multi-Mode Equalize Timer and Light;
adjustable from 1 - 144 hrs
~ Five selectable modes: Manual, 7-day, 14-day,
30-day and Equalize after Low DC Voltage
and/or AC Failure (Default Factory Setting)
- **Reset Button**
Restarts the Unit
- **Lamp Test Button**
Tests LCD Display & LED's

ALARM CONTACTS

- AC Failure
 - Low DC Voltage
 - High DC Voltage
 - Charger Failure
- Form "C" contact rated 10A @ 28VDC/120VAC

MONITORING

- **LCD Display**
Volts
Amps
Status
- **LED Indications**
Float (Green)
Equalize (Yellow)
AC ON (Green)
Charger Failure (Red)
Battery Fault (Red)
Current Limit (Red)
High DC Voltage (Red)
Low DC Voltage (Red)

ENVIRONMENTAL

- **Operating**
-20° to 50° C
- **Storage**
-40° to 85° C
- **Relative Humidity**
5% to 95% non-condensing

ENCLOSURE

- **Structural Design**
Wall Mount NEMA 1 powder coated
- **Cable Entry**
Left Side
6A model - Knockouts: left (2), right (1) and back (3)

STANDARDS

- UL1236
- CE
- Optional CUL
- IBC**
- OSHPD**
- ABS***
- NFPA 110
- C62.41A

** Refer to the manual for mounting information

*** May require Drip Shield based on site requirements

Model Number Nomenclature

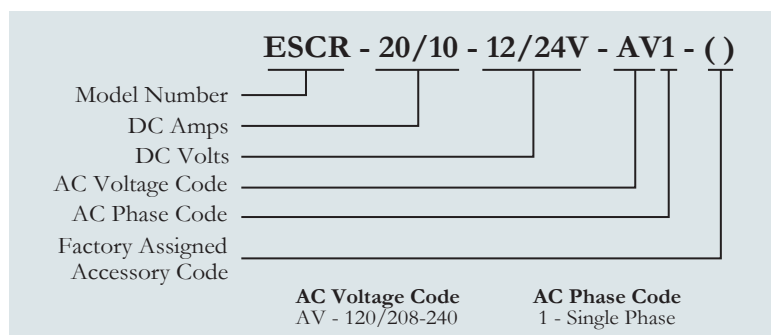

Front Panel Display

