

QT025A | 2.4L | 25 kW

INDUSTRIAL SPARK-IGNITED GENERATOR SET

EPA Certified Stationary Emergency

GENERAC® | INDUSTRIAL
POWER

Standby Power Rating

25 kW, 31 kVA, 60 Hz



*Assembled in the USA using domestic and foreign parts

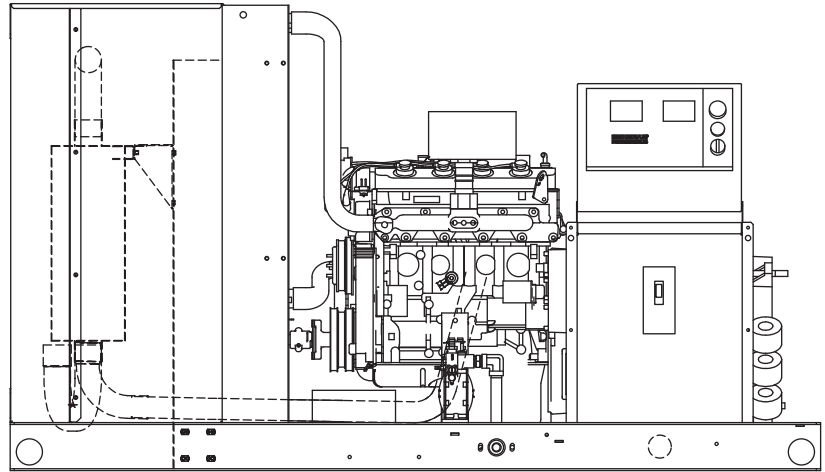

Image used for illustration purposes only

Codes and Standards

Not all codes and standards apply to all configurations. Contact factory for details.



UL2200, UL6200, UL1236, UL489



CSA C22.2, B149



BS5514 and DIN 6271



SAE J1349



NFPA 37, 70, 99, 110



NEC700, 701, 702, 708



ISO 3046, 7637, 8528, 9001



NEMA ICS10, MG1, 250, ICS6, AB1



ANSI C62.41



ASCE 7, ICC-ES AC-156

Powering Ahead

Generac ensures superior quality by designing and manufacturing most of its generator components, such as alternators, enclosures, control systems and communications software. Generac also makes its own spark-ignited engines, and you'll find them on every Generac gaseous-fueled generator. We engineer and manufacture them from the block up — all at our facilities throughout Wisconsin. Applying natural gas and LP-fueled engines to generators requires advanced engineering expertise to ensure reliability, durability and necessary performance. By designing specifically for these dry, hotter-burning fuels, the engines last longer and require less maintenance. Building our own engines also means we control every step of the supply chain and delivery process, so you benefit from single-source responsibility.

Plus, Generac Industrial Power's distribution network provides all parts and service so you don't have to deal with third-party suppliers. It all leads to a positive owner experience and higher confidence level. Generac spark-ignited engines give you more options in commercial and industrial generator applications as well as extended run time from utility-supplied natural gas.

QT025A | 2.4L | 25 kW

INDUSTRIAL SPARK-IGNITED GENERATOR SET

EPA Certified Stationary Emergency

GENERAC | INDUSTRIAL
POWER

STANDARD FEATURES

ENGINE SYSTEM

- Oil Drain Extension
- Heavy Duty Air Cleaner
- Stainless Steel Flexible Exhaust Connection
- Factory Filled Oil and Coolant
- Radiator Duct Adapter (Open Set Only)
- Critical Silencer (Enclosed Units Only)

FUEL SYSTEM

- Fuel Lockoff Solenoid
- Secondary Fuel Regulator
- Flexible Fuel Lines
- NPT Fuel Connection on Frame
- Primary and Secondary Fuel Shutoff

COOLING SYSTEM

- Closed Coolant Recovery System
- UV/Ozone Resistant Hoses
- Factory-Installed Radiator
- 50/50 Ethylene Glycol Antifreeze
- 120 VAC Coolant Heater

ELECTRICAL SYSTEM

- Battery Charging Alternator
- Battery Cables
- Battery Tray
- Rubber-Booted Engine Electrical Connections
- Solenoid Activated Starter Motor

ALTERNATOR SYSTEM

- UL2200 GENprotect™
- Fault Protection
- 10A UL Listed Float/Equalize Battery Charger
- Main Line Circuit Breaker
- Class H Insulation Material
- 2/3 Pitch
- Skewed Stator
- Sealed Bearings
- Full Load Capacity Alternator

GENERATOR SET

- Internal Genset Vibration Isolation
- Separation of Circuits - High/Low Voltage
- Separation of Circuits - Multiple Breakers
- Wrapped Exhaust Piping (Enclosed Units Only)
- Standard Factory Testing
- 2 Year Limited Warranty
- Silencer Mounted in the Discharge Hood (Enclosed Units Only)

ENCLOSURE (If Selected)

- Rust-Proof Fasteners with Nylon Washers to Protect Finish
- High Performance Sound-Absorbing Material (Sound Attenuated Enclosure)
- Gasketed Doors
- Upward Facing Discharge Hoods (Radiator and Exhaust)
- Lockable Handles
- Rhino Coat™ - Textured Polyester Powder Coat Paint

CONTROL SYSTEM



Digital H Control Panel- Dual 4x20 Display

Program Functions

- Programmable Crank Limiter
- 7-Day Programmable Exerciser
- Special Applications Programmable Logic Controller
- RS-232/485 Communications
- All Phase Sensing Digital Voltage Regulator
- 2-Wire Start Capability
- Date/Time Fault History (Event Log)
- Isochronous Governor Control
- Waterproof/Sealed Connectors

- Audible Alarms and Shutdowns
- Not in Auto (Flashing Light)
- Auto/Off/Manual Switch
- E-Stop (Red Mushroom-Type)
- NFPA110 Level I and II (Programmable)
- Customizable Alarms, Warnings, and Events
- Modbus® Protocol
- Predictive Maintenance Algorithm
- Sealed Boards
- Password Parameter Adjustment Protection
- Single Point Ground
- 16 Channel Remote Trending
- 0.2 msec High Speed Remote Trending
- Alarm Information Automatically Annunciated on the Display

Full System Status Display

- Power Output (kW)
- Power Factor
- kW Hours, Total, and Last Run
- Real/Reactive/Apparent Power
- All Phase AC Voltage
- All Phase Currents

- Oil Pressure
- Coolant Temperature
- Coolant Level
- Engine Speed
- Battery Voltage
- Frequency

Alarms and Warnings

- Oil Pressure
- Coolant Temperature
- Coolant Level
- Engine Overspeed
- Battery Voltage
- Alarms and Warnings Time and Date Stamped
- Snap Shots of Key Operation Parameters During Alarms and Warnings
- Alarms and Warnings Spelled Out (No Alarm Codes)

AVAILABLE OPTIONS

ENCLOSURE

- Sound Attenuated Enclosure
- Steel Enclosure
- Aluminum Enclosure

QT025A | 2.4L | 25 kW
INDUSTRIAL SPARK-IGNITED GENERATOR SET

EPA Certified Stationary Emergency

APPLICATION AND ENGINEERING DATA

ENGINE SPECIFICATIONS

General

Make	Generac
EPA Emissions Compliance	Stationary Emergency
EPA Emissions Engine Reference	See Emissions Data Sheet
Cylinder #	4
Type	In-Line
Displacement - in ³ (L)	146.4 (2.4)
Bore - in (mm)	3.41 (86.61)
Stroke - in (mm)	3.94 (100.08)
Compression Ratio	9.5:1
Intake Air Method	Naturally Aspirated
Number of Main Bearings	5
Connecting Rods	Forged Steel
Cylinder Head	Aluminum
Cylinder Liners	No
Ignition	High Energy
Piston Type	Aluminum Alloy
Crankshaft Type	Cast Steel
Lifter Type	Overhead Cam
Intake Valve Material	Steel Alloy
Exhaust Valve Material	Hardened Steel
Hardened Valve Seats	Yes

Engine Governing

Governor	Electronic
Frequency Regulation (Steady State)	±0.25%

Lubrication System

Oil Pump Type	Gear
Oil Filter Type	Full Flow Spin-on Cartridge
Crankcase Capacity - qt (L)	4.0 (3.8)

Cooling System

Cooling System Type	Pressurized Closed Recovery
Fan Type	Pusher
Fan Speed - RPM	1,980
Fan Diameter - in (mm)	18 (457)

Fuel System

Fuel Type	Natural Gas, Propane Vapor
Carburetor	Down Draft
Secondary Fuel Regulator	Standard
Fuel Shut Off Solenoid	Standard
Operating Fuel Pressure - in H ₂ O (kPa)	5 - 14 (1.2 - 3.5) (Contact Factory for Details)

Engine Electrical System

System Voltage	12 VDC
Battery Charger Alternator	Standard
Battery Size	See Battery Index 0161970SBY
Battery Voltage	12 VDC
Ground Polarity	Negative

ALTERNATOR SPECIFICATIONS

Standard Model	K0025124Y21
Poles	4
Field Type	Revolving
Insulation Class - Rotor	F
Insulation Class - Stator	H
Total Harmonic Distortion	<5% (3-Phase Only)
Telephone Interference Factor (TIF)	<50
Standard Excitation	Direct

Bearings	Sealed Ball
Coupling	Direct via Flexible Disc
Load Capacity - Standby	100%
Prototype Short Circuit Test	Yes
Voltage Regulator Type	Full Digital
Number of Sensed Phases	All
Regulation Accuracy (Steady State)	±0.25%

EPA Certified Stationary Emergency

OPERATING DATA

POWER RATINGS - NATURAL GAS/PROPANE VAPOR

		Standby
Single-Phase 120/240 VAC @1.0pf	25 kW	Amps: 104
Three-Phase 120/208 VAC @0.8pf	25 kW	Amps: 87
Three-Phase 120/240 VAC @0.8pf	25 kW	Amps: 75
Three-Phase 277/480 VAC @0.8pf	25 kW	Amps: 38

MOTOR STARTING CAPABILITIES (skVA)

skVA vs. Voltage Dip

120/240 VAC 1Ø	30%	277/480 VAC 3Ø	30%	120/208 VAC 3Ø	30%
0G2134001R	12	0G2136001R	50	0G2135001R	50

FUEL CONSUMPTION RATES*

Natural Gas – scfm (m³/hr)		Propane Vapor – scfm (m³/hr)	
Percent Load	Standby	Percent Load	Standby
25%	140 (3.9)	25%	56 (1.6)
50%	220 (6.2)	50%	87 (2.5)
75%	300 (8.5)	75%	119 (3.4)
100%	380 (10.8)	100%	151 (4.3)

* Fuel supply installation must accommodate fuel consumption rates at 100% load.

COOLING

		Standby
Air Flow (Fan Air Flow Across Radiator)	cfm (m³/min)	1,500 (42.48)
Coolant Flow	gpm (Lpm)	42 (160)
Coolant System Capacity	gal (L)	2.5 (9.5)
Maximum Operating Ambient Temperature	°F (°C)	122 (50)
Maximum Operating Ambient Temperature (Before Derate)		See Bulletin No. 0199270SSD
Maximum Additional Radiator Backpressure	in H ₂ O (kPa)	0.5 (0.12)

COMBUSTION AIR REQUIREMENTS

	Standby
Flow at Rated Power - cfm (m³/min)	70 (2.0)

ENGINE

		Standby
Rated Engine Speed	RPM	1,800
Horsepower at Rated kW**	hp	40
Piston Speed	ft/min (m/min)	1,182 (360.3)
BMEP	psi (kPa)	120 (827)

EXHAUST

		Standby
Exhaust Flow (Rated Output)	cfm (m³/min)	220 (6.2)
Maximum Allowable Backpressure (Post Silencer)	inHg (kPa)	1.5 (5.1)
Exhaust Temperature (Rated Output - Post Silencer)	°F (°C)	975 (524)

** Refer to "Emissions Data Sheet" for maximum bHP for EPA and SCAQMD permitting purposes.

Deration – Operational characteristics consider maximum ambient conditions. Derate factors may apply under atypical site conditions. Please contact a Generac Power Systems Industrial Dealer for additional details. All performance ratings in accordance with ISO3046, BS5514, ISO8528, and DIN6271 standards. Standby – See Bulletin 10000018933

DIMENSIONS AND WEIGHTS*

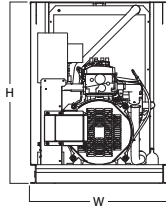
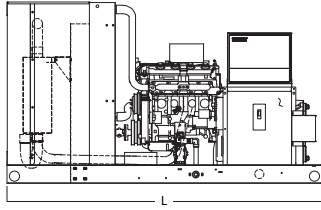

OPEN SET

L x W x H - in (mm)	77.0 (1,956) x 43.0 (864) x 34.0 (1,092)
Weight - lbs (kg)	1,163 (528)

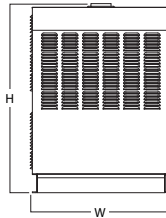
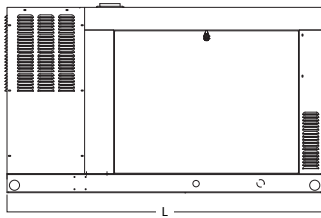

SOUND ATTENUATED ENCLOSURE

L x W x H - in (mm)	77.0 (1,956) x 46.0 (864) x 34.0 (1,168)
Weight - lbs (kg)	1,414 (641)

* All measurements are approximate and for estimation purposes only.

YOUR FACTORY RECOGNIZED GENERAC INDUSTRIAL DEALER

Specification characteristics may change without notice. Please contact a Generac Power Systems Industrial Dealer for detailed installation drawings.