

Generator

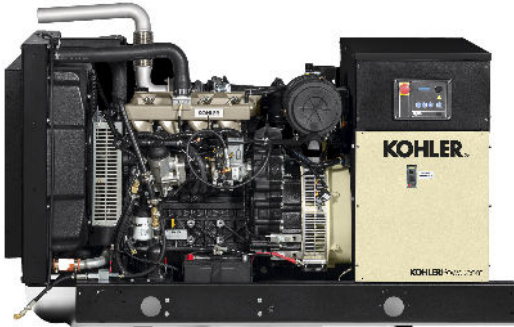

Kohler Model: 50REOZK

This diesel generator set equipped with a 4P7BX alternator operating at 120/208 volts is rated for 51 kW/63 kVA. Output amperage: 176

Standard Features:

- Kohler Co. provides one-source responsibility for the generating system and accessories.
- Approved for use with certified renewable Hydrotreated Vegetable Oil (HVO) / Renewable Diesel (RD) fuels compliant with EN15940/ASTM D975.
- The generator set and its components are prototype-tested, factory-built, and production-tested.
- The 60 Hz generator set offers a UL 2200 listing.
- The generator set accepts rated load in one step.
- The 60 Hz generator set meets NFPA 110, Level 1, when equipped with the necessary accessories and installed per NFPA standards.
- The generator set engine is certified to meet the Environmental Protection Agency (EPA) emergency stationary emissions requirements.
- Tier 3 EPA-Certified for Stationary Emergency Applications (Not for sale in California)
- A one-year limited warranty covers all generator set systems and components. Two-and five-year extended limited warranties are also available.
- Air Cleaner, Heavy Duty
- Alternator Protection
- Battery Rack and Cables
- Open Crankcase Ventilation
- Oil Drain and Coolant Drain with Hose Barb
- Oil Drain Extension (with narrow skid and enclosure models only)
- Operation and Installation Literature
- Radiator Drain Extension (with enclosure models only)
- Stainless Steel Fasteners on Enclosure (with enclosure models only)

Other Features:

- Kohler designed controllers for guaranteed system integration and remote communication. See Controller son page 3.
- The low coolant level shutdown prevents overheating (standard on radiator models only.)Integral vibration isolation eliminates the need for under-unit vibration spring isolators.

Alternator Features:

- The unique Fast-Response X excitation system delivers excellent voltage response and short-circuit capability using a rare-earth, permanent magnet (PM)-excited alternator
- The brushless, rotating-field alternator has broadrange reconnectability.

Qty	Description
	50REOZK Generator System
13	50REOZK Generator Set
	Includes the following:
	Literature Languages English
	Approvals and Listings UL2200 Listing
	Engine 50REOZK, 12V, 60Hz, KDI3404TM
	Nameplate Rating Standby 130C Rise
	Voltage 60Hz, 120/208V, Wye, 3Ph, 4W
	Alternator 4P7BX
	Cooling System Unit Mounted Radiator, 50C
	Skid and Mounting Skid/Tank
	Air Intake Heavy Duty
	Controller APM402
	Enclosure Type Sound
	Enclosure Material Steel
	Enclosure Silencer Internal Silencer
	Fuel Tank Type State
	Fuel Runtime (Approx.) 24 Hours
	Subbase Fuel Tank Capacity 142 Gallons
	Starting Aids, Installed 1000W,110-120V
	Electrical Accy.,Installed Battery, 1/12V, Wet
	Electrical Accy.,Installed Battery Charger, 10A
	Electrical Accy.,Installed Run Relay
	Electrical Accy.,Installed 2 Input/5 OutputModule
	Electrical Accy.,Installed Governor, Electronic
	Rating, LCB 1 100% Rated
	Amps, LCB 1 200
	Trip Type, LCB 1 Thermal Magnetic
	Interrupt Rating LCB 1 18kA at 480V
	Fuel Lines, Installed Flexible Fuel Lines
	Miscellaneous Accy,Installed Air Cleaner Restriction Ind.
	Miscellaneous Accy,Installed Coolant in Genset
	Miscellaneous Accy,Installed Oil in Genset
	Warranty 5 Year Comprehensive
	Testing, Additional Power Factor Test,0.8,3Ph Only
13	NEC Remote, E-Stop
13	Lit Kit, General Maint., 50REOZK
13	RSA III, Annunciator only

KOHLER®

Spec Sheets

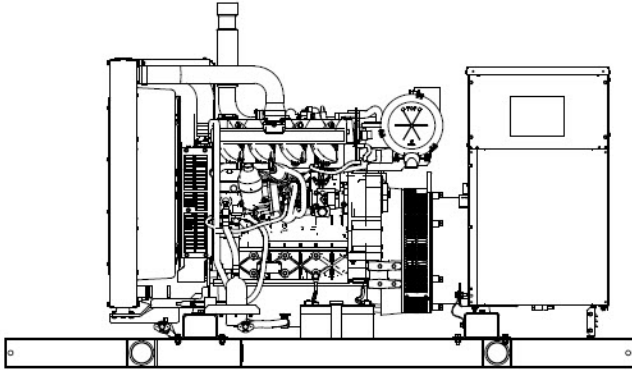

Standard Features

- Kohler Co. provides one-source responsibility for the generating system and accessories.
- Approved for use with certified renewable Hydrotreated Vegetable Oil (HVO) / Renewable Diesel (RD) fuels compliant with EN15940/ASTM D975.
- The generator set and its components are prototype-tested, factory-built, and production-tested.
- The 60 Hz generator set offers a UL 2200 listing.
- The generator set accepts rated load in one step.
- The 60 Hz generator set meets NFPA 110, Level 1, when equipped with the necessary accessories and installed per NFPA standards.
- The generator set engine is certified to meet the Environmental Protection Agency (EPA) emergency stationary emissions requirements.
- Tier 3 EPA-Certified for Stationary Emergency Applications (Not for sale in California)
- A one-year limited warranty covers all generator set systems and components. Two-and five-year extended limited warranties are also available.
- Air Cleaner, Heavy Duty
- Alternator Protection
- Battery Rack and Cables
- Open Crankcase Ventilation
- Oil Drain and Coolant Drain with Hose Barb
- Oil Drain Extension (with narrow skid and enclosure models only)
- Operation and Installation Literature
- Radiator Drain Extension (with enclosure models only)
- Stainless Steel Fasteners on Enclosure (with enclosure models only)

Alternator Features

- The unique Fast-Response X excitation system delivers excellent voltage response and short-circuit capability using a rare-earth, permanent magnet (PM)-excited alternator
- The brushless, rotating-field alternator has broadrange reconnectability.

Other Features

- Kohler designed controllers for guaranteed system integration and remote communication. See Controller on page 3.
- The low coolant level shutdown prevents overheating (standard on radiator models only.)Integral vibration isolation eliminates the need for under-unit vibration spring isolators.

Generator Set Rating

Standby 130C Rise Ratings

Alternator	Voltage	Ph	Hz	Peak kVA	kW/kVA	Amps
4P7BX	120/208	3	60	135	51/63	176

Model: 50REOZK, continued

Alternator Specifications

Specifications	Alternator
Alternator manufacturer	Kohler
Type	4-Pole, Rotating-Field
Exciter type	Brushless, Rare-Earth Permanent-Magnet
Leads, quantity	12, Reconnectable 4, 110-120/220-240
Voltage regulator	Solid State, Volts/Hz
Insulation	NEMA MG1
Insulation: Material	Class H
Insulation: Temperature Rise	130 ° C, 150 ° C Standby
Bearing: quantity, type	1, Sealed
Coupling	Flexible Disc
Amortisseur windings	Full
Voltage regulation, no-load to full-load RMS	Controller Dependent
One-Step Load Acceptance	100% of rating
Unbalanced load capability	100% of Rated Standby Current

- NEMA MG1, IEEE, and ANSI standards compliance for temperature rise and motor starting.
- Sustained short-circuit current of up to 300% of the rated current for up to 10 seconds.
- Sustained short-circuit current enabling downstream circuit breakers to trip without collapsing the alternator field.
- Self-ventilated and dripproof construction.
- Windings are vacuum-impregnated with epoxy varnish for dependability and long life.
- Superior voltage waveform from a two-thirds pitch stator and skewed rotor.

Engine

Engine Specification

Engine Manufacturer	Kohler Diesel
Engine Model	KDI 3404TM
Engine: type	4-Cycle, Turbocharged
Cylinder arrangement	4 Inline
Displacement, L (cu. in.)	3.4 (207)
Bore and stroke, mm (in.)	96 x 116 (3.28 x 4.57)
Compression ratio	18.5:1
Piston speed, m/min. (ft./min.)	418 (1371)
Main bearings: quantity, type	5, Replaceable Insert
Rated rpm	1800
Max. power at rated rpm, kWm (BHP)	64 (86)
Cylinder head material	Cast Iron
Valve (exhaust) material Intake	Chromium-Silicon Steel
Valve (exhaust) material	Chromium Steel
Governor: type, make/model	Stanadyne/Mechanical
Frequency regulation, no-load to-full load	Droop, 5% (or Isochronous)
Frequency regulation, steady state	± 0.5%
Frequency	Fixed
Air cleaner type, all models	Dry

Model: 50REOZK, continued

Exhaust

Exhaust System

Exhaust Manifold Type	Dry
Exhaust flow at rated kW, m3/min. (cfm)	8.8 (310)
Exhaust temperature at rated kW, dry exhaust, °C (°F)	490 (914)
Maximum allowable back pressure, kPa (in. Hg)	6 (1.8)/9 (2.7)
Exh. outlet size at eng. hookup, mm (in.)	63.5 (2.5)

Engine Electrical

Engine Electrical System

Battery charging alternator: Ground (negative/positive)	Negative
Battery charging alternator: Volts (DC)	12
Battery charging alternator: Ampere rating	90
Starter motor rated voltage (DC)	12
Battery, recommended cold cranking amps (CCA): Qty., CCA rating each	One, 650
Battery voltage (DC)	12

Fuel

Fuel System

Fuel type	Diesel
Fuel supply line, min. ID, mm (in.)	8.0 (0.31)
Fuel return line, min. ID, mm (in.)	6.0 (0.25)
Max. lift, engine-driven fuel pump, m (ft.)	6.0 (20.0)
Max. fuel flow, Lph (gph)	46 (12.2)
Max. return line restriction, kPa (in. Hg)	20 (5.9)
Fuel Filter: Prefilter	74 Microns
Fuel Filter Water Separator	5 Microns @ 98% Efficiency
Recommended fuel	#2 Ultra Low Sulfur Diesel /HVO / RD

Lubrication

Lubrication System

Type	Full Pressure
Oil pan capacity, L (qt.)	15.3 (16.2)
Oil pan capacity with filter, L (qt.)	15.6 (16.5)
Oil filter: quantity, type	1, Cartridge
Oil cooler	Water-Cooled

Model: 50REOZK, continued

Cooling

Radiator System

Ambient temperature, ° C (° F)	50 (122)
Engine jacket water capacity, L (gal.)	4.5 (1.19)
Radiator system capacity, including engine, L (gal.)	12.3 (3.2)
Engine jacket water flow, Lpm (gpm)	125 (33)
Heat rejected to cooling water at rated kW, dry exhaust, kW (Btu/min.)	37.8 (2207)
Heat rejected to air charge cooler at rated kW, dry exhaust, kW (Btu/min.)	12 (682)
Water pump type	Centrifugal
Fan diameter, including blades, mm (in.)	597 (23.5)
Fan, kWm (HP)	1.8 (2.3)
Max. restriction of cooling air, intake and discharge side of radiator, kPA (in. H ₂ O)	0.125 (0.5)

* Enclosure with enclosed silencer reduces ambient temperature capability by 5 ° C (9 ° F).

Operation Requirements

Air Requirements

Radiator-cooled cooling air, m ³ /min. (scfm) *	96.3 (3400)
Combustion air, m ³ /min. (cfm)	4.8 (170)
Heat rejected to ambient air: Engine, kW (Btu/min.)	13.2 (750)
Heat rejected to ambient air: Alternator, kW (Btu/min.)	7.6 (435)
Max. air intake restriction, kPa (in. Hg)	5.2 (1.54)

*Air density = 1.20 kg/m³ (0.075 lbm/ft³)

Fuel Consumption

Diesel, Lph (gph), at % load

Rating

Standby Fuel Consumption at 100% load	17.4 Lph (4.6 gph)
Standby Fuel Consumption at 75% load	13.2 Lph (3.5 gph)
Standby Fuel Consumption at 50% load	9.1 Lph (2.4 gph)
Standby Fuel Consumption at 25% load	5.3 Lph (1.4 gph)

Kohler® APM402 Controller**General Description and Function**

The APM402 generator set controller provides advanced control, system monitoring, and system diagnostics for optimum performance.

The APM402 controller meets NFPA 110, Level 1 when equipped with the necessary accessories and installed per NFPA standards.

The APM402 controller uses a patented hybrid voltage regulator and unique software logic to manage alternator thermal overload protection features normally requiring additional hardware. Additional features include:

- A digital display and pushbutton/rotary selector dial provide easy local access to data.
- Measurements selectable in metric or English units.
- The controller can communicate directly with a personal computer via a network or serial configuration using SiteTech™ or Monitor III software.
- The controller supports Modbus® protocol. Use with serial bus or Ethernet networks. (Ethernet requires an external Modbus®/Ethernet converter module.)
- Scrolling display shows critical data at a glance.
- Digital display of power metering (kW and kVA).
- Integrated hybrid voltage regulator providing $\pm 0.5\%$ regulation.
- Built-in alternator thermal overload protection.

Modbus® is a registered trademark of Schneider Electric.

**APM402**

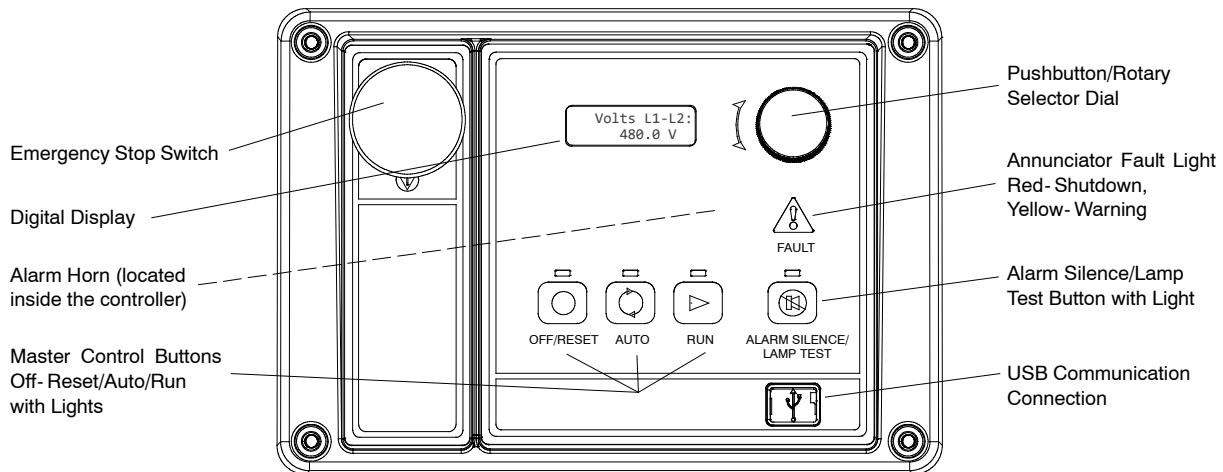

User Interface Controls and Components

- Emergency stop switch
- Backlit LCD digital display with two lines of 12 characters (see *User Interface Displays for menus*)
- Alarm horn indicates generator set shutdown and warning faults
- Environmentally sealed membrane keypad with three master control buttons with lights
 - Off/Reset (red)
 - Auto (green)
 - Run (yellow)
- Pushbutton/rotary selector dial for menu navigation
 - Rotate dial to access main menus
 - Push dial and rotate to access sub menus
 - Press dial for 3 seconds to return to top of main menu
- Annunciator fault light
 - System shutdown (red)
 - System warning (yellow)
- Alarm silence/lamp test button
 - Alarm silence
 - Lamp test
- USB and RS-485 connections
 - Allows software upgrades
 - Provides access for diagnostics
 - PC communication using SiteTech™ or Monitor III software
- Dedicated user inputs
 - Remote emergency stop switch
 - Remote 2-wire start for transfer switch
 - Auxiliary shutdown
- Integrated hybrid voltage regulator
- Auto-resettable circuit protection mounted on circuit board.
- One relay output standard. Optional five relay output available.
- One analog and three digital inputs standard. Optional two inputs available.

NFPA 110 Requirements

In order to meet NFPA 110, Level 1 requirements, the generator set controller monitors the engine/generator functions/faults shown below.

- Engine functions:
 - Overcrank
 - Low coolant temperature warning
 - High coolant temperature warning
 - High coolant temperature shutdown
 - Low oil pressure shutdown
 - Low oil pressure warning
 - High engine speed
 - Low fuel (level or pressure) *
 - Low coolant level
 - EPS supplying load
 - High battery voltage
 - Low battery voltage
- General functions:
 - Master switch not in auto
 - Battery charger fault *
 - Lamp test
 - Contacts for local and remote common alarm
 - Audible alarm silence button
 - Remote emergency stop *

* Function requires optional input sensors or kits and is engine dependent, see Controller Displays as Provided by the Engine ECM.

User Interface Displays

The listing below has ● denoting main menus and ○ denoting sub-menus.

- Overview
 - Software version
 - Active shutdowns and warnings (if any are present)
 - Engine run time, total hours
 - Average voltage line-to-line
 - Frequency
 - Average current
 - Coolant temperature
 - Fuel level or pressure *
 - Oil pressure
 - Battery voltage
- Engine Metering
 - Engine speed
 - Oil pressure
 - Coolant temperature
 - Battery voltage
- Generator Metering
 - Total power, VA
 - Total power, W
 - Rated power, %
 - Voltage, L-L and L-N for all phases
 - Current, L1, L2, L3
 - Frequency
- GenSet Information
 - Generator set model number
 - Generator set serial number
 - Controller serial number
- GenSet Run Time
 - Engine run time, total hours
 - Engine loaded, hours
 - Number of engine starts
 - Total energy, kWh
- GenSet System
 - System voltage
 - System frequency, 50 or 60 Hz
 - System phase, single or three (wye or delta)
 - Power rating, kW
 - Amp rating
 - Power type, standby or prime
 - Measurement units, metric or English (user selectable)
 - Alarm silence, always or auto only (NFPA 110)
 - Manual speed adjust *
- GenSet Calibration
 - Voltage, L-L and L-N for all phases
 - Current, L1, L2, L3
 - Reset calibration
- Voltage Regulation
 - Adjust voltage, ±10%
- Digital Inputs
 - Input settings and status
- Digital Outputs
 - Output settings and status
- Analog Inputs
 - Input settings and status
- Event Log
 - Event history (stores up to 1000 system events)
- Selector Switch (requires initial activation by SiteTech™)

Controller Features

- **AC Output Voltage Regulator Adjustment.** The voltage adjustment provides a maximum of $\pm 10\%$ of the system voltage.
- **Alarm Silence.** The controller can be set up to silence the alarm horn only when in the AUTO mode for NFPA-110 application or Always for user convenience.
- **Alternator Protection.** The controller provides generator set overload and short circuit protection matched to each alternator for the particular voltage/phase configuration.
- **Automatic Restart.** The controller automatic restart feature initiates the start routine and re crank after a failed start attempt.
- **Common Failure Relay.** This relay is integrated on the controller circuit board. Contacts are rated 2 amps at 32 VDC or 0.5 amp at 120 VAC.
- **Communication.** Controller communication is available.
- **Cyclic Cranking.** The controller has programmable cyclic cranking.
- **ECM Diagnostics.** The controller displays engine ECM fault code descriptions to help in engine troubleshooting.
- **Engine Start Aid.** The starting aid feature provides control for an optional engine starting aid.
- **Event Logging.** The controller keeps a record (up to 1000 entries) for warning and shutdown faults. This fault information becomes a stored record of system events and can be reset.
- **Historical Data Logging.** Total number of generator set successful starts is recorded and displayed.
- **Integrated Hybrid Voltage Regulator.** The voltage regulator provides $\pm 0.5\%$ no-load to full-load regulation with three-phase sensing.
- **Lamp Test.** Press the alarm silence/lamp test button to verify functionality of the indicator lights.
- **LCD Display.** Adjustable contrast for improving visibility.
- **Measurement Units.** The controller provides selection of English or metric displays.
- **Power Metering.** Controller digital display provides kW and kVA.
- **Programming Access (USB).** Provides software upgrades and diagnostics.
- **Remote Reset.** The remote reset function resets faults and allows restarting of the generator set without going to the master control switch off/reset position.
- **Remote Monitoring Panel.** The controller is compatible with the Kohler® Remote Serial Annunciator.
- **Run Time Hourmeter.** The generator set run time is displayed.
- **Time Delay Engine Cooldown (TDEC).** The TDEC provides a time delay before the generator set shuts down.
- **Time Delay Engine Start (TDES).** The TDES provides a time delay before the generator set starts.
- **Voltage Selection Menu.** This menu provides the capability of quickly switching controller voltage calibrations. Requires initial activation using SiteTech™ software. **NOTE:** Generator set output leads require voltage reconnection.

Controller Functions

The following chart shows which functions cause a warning or shutdown. All functions are available as relay outputs.

Warning causes the fault light to show yellow and sounds the alarm horn signaling an impending problem.

Shutdown causes the fault light to show red, sounds the alarm horn, and stops the generator set.

	Warning Function	Shutdown Function
Engine Functions		
Critically high fuel level *	○	
ECM communication loss		●
ECM diagnostics	●	●
Engine over speed		●†
Engine start aid active		
Engine under speed		●
Fuel tank leak *	○	○
High battery voltage	●	
High coolant temperature	●	●†
High fuel level *	○	
Low battery voltage	●	
Low coolant level		●
Low coolant temperature	●	
Low cranking voltage	●	
Low engine oil level *	○	○
Low fuel level (diesel models) *	○	○
Low fuel pressure (gas models) *	○	
Low oil pressure	●	●†
No coolant temperature signal		●
No oil pressure signal		●
Overcrank		●†
Speed sensor fault	●	
General Functions		
Alarm horn silenced		
Analog inputs	○	○
Battery charger fault *	●	
Chicago code active *		
Common fault (includes †)		●
Common warning	●	
Digital inputs	○	○
Emergency stop		●†
Engine cooldown (delay) active		
Engine start delay active		
Engine started		
Engine stopped		
EPS supplying load		
Generator running		
Input/output communication loss	●	
Internal failure		●
Master switch not in auto	●	
NFPA 110 alarm active		
Remote start		
System ready		
Generator Functions		
AC sensing loss	●	●
Alternator protection		●
Ground fault input *	●	
kW overload		●
Locked rotor		●
Overfrequency		●
Overvoltage (each phase)		●
Underfrequency		●
Undervoltage (each phase)		●

● Standard function

○ Available user function

* Function requires optional input sensors or kits and is engine dependent; see Controller Displays as Provided by the Engine ECM.

† Items included with common fault shutdown



KOHLER CO., Kohler, Wisconsin 53044 USA
 Phone 920-457-4441, Fax 920-459-1646
 For the nearest sales and service outlet in the
 US and Canada, phone 1-800-544-2444
 KOHLERPower.com

Controller Displays as Provided by the Engine ECM	Engine Manufacturer (and Model)						
	Kohler Diesel (KDI M, TM*)	Kohler Diesel (KDI TCR)	Kohler Gas (KG2204, KG2204T)	Kohler Gas (KG6208, KG6208T, KG10V08, KG10V08T)	GM and PSI/Doosan	John Deere	Volvo
Intake air pressure							D
Intake air Temperature		D		D	D	D	D
Coolant level			D	D	D	D	D
Coolant temperature		D	C/S/D	C/S/D	C/S/D	C/S/D	C/S/D
Crankcase pressure							D
ECM battery voltage	S		S/D	S	S		
Engine speed	C/S/D	C/S/D	C/S/D	C/S/D	C/S/D	C/S/D	C/S/D
Fuel pressure		D		C/S/D	C/S/D	C/S†	C/S/D
Fuel temperature		D				S/D	S
Oil level				S†	S†	S†	S†
Oil pressure		C/S/D	D	C/S/D	C/S/D	C/S/D	C/S/D
Oil temperature			S				SD

C = Value displayed on controller, S = Value displayed in Site Tech, D = ECU diagnostic is supported
 * Electronic governor and ECM are optional on KDI M and TM engines.
 † Controller uses local analog input to obtain this information.

Note: REOZMD/ROZMC (Mitsubishi engines) have an ECM but do not send signals to the generator set controller.

Note: See the generator set specification sheet for engine model identification.

Controller Specifications

- Power source with circuit protection: 12- or 24-volt DC
- Power drain: 200 milliamps at 12 VDC or 100 milliamps at 24 VDC
- Humidity range: 5% to 95% noncondensing
- Operating temperature range: -40°C to +70°C (-40°F to +158°F)
- Storage temperature range: -40°C to +85°C (-40°F to +185°F)
- Standards:
 - CE Directive
 - NFPA 99
 - NFPA 110, Level 1
 - CSA 282-09
 - UL 508
 - ASTM B117 (salt spray test)
- Panel dimensions—W x H, 229 x 160 mm (9.0 x 6.3 in.)

Communication and PC Software Available Options

Refer to G6-76 Monitor III Software and the communication literature for additional communication and PC software information including Modbus® communication.

- Monitor III Software for Monitoring and Control (Windows®-based user interface)**
- Converter, Modbus®/Ethernet.** Supports a power system using controllers accessed via the Ethernet. Converter is supplied with an IP address by the site administrator. Refer to G6-79 for converter details.
- Converter, RS-232/RS-485.** Supports a power system using controllers accessed via a serial (RS-232) connection.

APM402 Available Options

- Float/Equalize Battery Charger** available with 6 or 10 amp output for 12 or 24V DC voltage output. The 10 amp model provides NFPA 110 charging and alarming capability.
- Manual Speed Adjust** available for applications using closed transition ATS. Adjustment range for 60 Hz: 1751- 1849 rpm (58.2- 61.8 Hz) and for 50 Hz: 1451- 1549 rpm (48.2- 51.8 Hz).
- Prime Power Switch** prevents battery drain during generator set non-operation periods and when the generator set battery cannot be maintained by an AC battery charger.
- Remote Emergency Stop Switch** available as a wall mounted panel to remotely shut down the generator set.
- Remote Monitoring Panel.** The Kohler® Remote Serial Annunciator (RSA) enables the operator to monitor the status of the generator set from a remote location, which may be required for NFPA 99 and NFPA 110 installations, and up to four Automatic transfer switches.
- Run Relay** provides a relay indicating that the generator set is running.
- Shunt Trip Wiring** provides relay outputs to trip a shunt trip circuit breaker and to signal the common fault shutdowns. Contacts rated at 10 amps at 28 VDC or 120 VAC.
- Two Input/Five Output Module** provides a generator set mounted panel with two inputs and five relay outputs.

Windows® is a registered trademark of Microsoft Corporation.
 Modbus® is a registered trademark of Schneider Electric.

DISTRIBUTED BY:

Availability is subject to change without notice. Kohler Co. reserves the right to change the design or specifications without notice and without any obligation or liability whatsoever. Contact your local Kohler® generator set distributor for availability.

© 2018 Kohler Co., All rights reserved.

Line Circuit Breakers 15-3250 kW

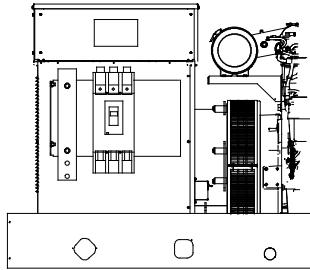

**Single Circuit Breaker Kit with Neutral Bus Bar
15-300 kW Model Shown**

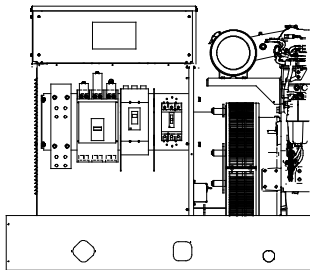

**Multiple Circuit Breaker Kit with Neutral Bus Bar
180-300 kW Model Shown**

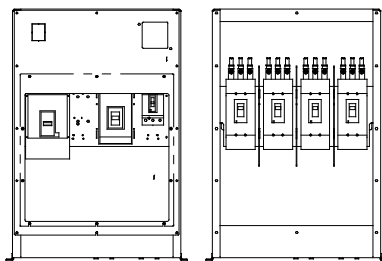

**Multiple Circuit Breaker Kits with Neutral Bus Bar
350-2250 kW Model Shown
(also applies to some 300 kW models)**

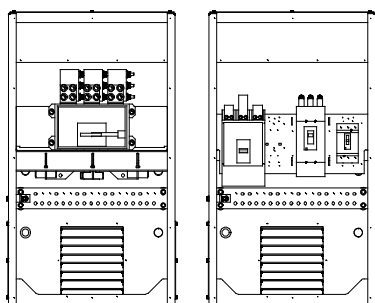

**Circuit Breaker Kits with Neutral Bus Bar
800-2500 kW KD Model Shown**

Standard Features

- The line circuit breaker interrupts the generator set output during a short circuit and protects the wiring when an overload occurs. Use the circuit breaker to manually disconnect the generator set from the load during generator set service.
- Circuit breaker kits are mounted to the generator set and are provided with load-side lugs and neutral bus bar.
- Kohler Co. offers a wide selection of molded-case line circuit breaker kits including single, dual, and multiple configurations for each generator set.
- Four types of line circuit breakers are available: (see page 2 for definitions and pages 3 and 4 for application details)
 - Magnetic trip
 - **Thermal magnetic trip**
 - Electronic trip
 - Electronic with ground fault (LSIG) trip
- In addition, line circuit breakers are offered with 80% and 100% ratings.
- Single line circuit breaker kits allow circuit protection of the entire electrical system load.
- Dual line circuit breaker kits allow circuit protection of selected priority loads from the remaining electrical system load.
- Multiple line circuit breaker kits with field connection barrier allow circuit protection for special applications (350- 2500 kW models and selected 80- 300 kW models).
- Up to four line circuit breakers can be used on 350- 2500 kW models.
- Line circuit breakers comply with the following codes and standards unless otherwise stated.
 - UL 489 Molded Case Circuit Breakers
 - UL 1077 Supplementary Protectors
 - UL 2200 Stationary Engine Generator Assemblies

Line Circuit Breaker Types

Magnetic Trip

The magnetic trip features an electromagnet in series with the load contacts and a moveable armature to activate the trip mechanism. When a sudden and excessive current such as a short circuit occurs, the electromagnet attracts the armature resulting in an instantaneous trip.

Thermal Magnetic Trip

Thermal magnetic trip contains a thermal portion with a bimetallic strip that reacts to the heat produced from the load current. Excessive current causes it to bend sufficiently to trip the mechanism. The trip delay is dependent on the duration and excess of the overload current. Elements are factory-calibrated. A combination of both thermal and magnetic features allows a delayed trip on an overload and an instantaneous trip on a short circuit condition.

Electronic Trip

These line circuit breakers use electronic controls and miniature current transformers to monitor electrical currents and trip when preset limits are exceeded.

LI breakers are a combination of adjustable trip functions including long-time ampere rating, long-time delay, and instantaneous pickup. LSI breakers have all of the LI breaker features plus short-time pickup, short-time delay, and defeatable instantaneous pickup. LSIG breakers have all of the LSI breaker features plus ground-fault pickup and delay.

NOTE: MG-frame does not have a long-time delay when selected with LI breakers.

Electronic with Ground Fault Trip

The ground fault trip feature is referred to as LSIG in this document. Models with LSIG compare current flow in phase and neutral lines, and trip when current unbalance exists.

Ground fault trip units are an integral part of the circuit breaker and are not available as field-installable kits. The ground fault pickup switch sets the current level at which the circuit breaker will trip after the ground fault delay. Ground fault pickup values are based on circuit breaker sensor plug only and not on the rating plug multiplier. Changing the rating plug multiplier has no effect on the ground fault pickup values.

80% Rated Circuit Breaker

Most molded-case circuit breakers are 80% rated devices. An 80% rated circuit breaker can only be applied at 80% of its rating for continuous loads as defined by NFPA 70. Circuit conductors used with 80% rated circuit breakers are required to be rated for 100% of the circuit breaker's rating.

The 80% rated circuit breakers are typically at a lower cost than the 100% rated circuit breaker but load growth is limited.

100% Rated Circuit Breaker

Applications where all UL and NEC restrictions are met can use 100% rated circuit breakers where 100% rated circuits can carry 100% of the circuit breaker and conductor current rating.

The 100% rated circuit breakers are typically at a higher cost than the 80% rated circuit breaker but have load growth possibilities.

When applying 100% rated circuit breakers, comply with the various restrictions including UL Standard 489 and NEC Section 210. If any of the 100% rated circuit breaker restrictions are not met, the circuit breaker becomes an 80% rated circuit breaker.

Line Circuit Breaker Options

Alarm Switch

The alarm switch indicates that the circuit breaker is in a tripped position caused by an overload, short circuit, ground fault, the operation of the shunt trip, an undervoltage trip, or the push-to-trip pushbutton. The alarm resets when the circuit breaker is reset.

Auxiliary Contacts

These switches send a signal indicating whether the main circuit breaker contacts are in the open or closed position.

Breaker Separators (350- 2500 kW)

Provides adequate clearance between breaker circuits.

Bus Bars

Bus bar kits offer a convenient way to connect load leads to the generator set when a circuit breaker is not present. **15- 300 kW.** Bus bar kits are available on alternators with leads for connection to the generator set when circuit breakers are not ordered.

350- 2500 kW. A bus bar kit is provided when no circuit breaker is ordered. Bus bars are also available in combination with circuit breakers or other bus bars on the opposite side of the junction box. On medium voltage (3.3 kV and above) units, a bus bar kit is standard (not applicable to KD models).

Field Connection Barrier

Provides installer wiring isolation from factory connections.

Ground Fault Annunciation

A relay contact for customer connection indicates a ground fault condition and is part of a ground fault alarm.

Lockout Device (padlock attachment)

This field-installable handle padlock attachment is available for manually operated circuit breakers. The attachment can accommodate three padlocks and will lock the circuit breaker in the OFF position only.

Lugs

Various lug sizes are available to accommodate multiple cable sizes for connection to the neutral or bus bar.

Overcurrent Trip Switch

The overcurrent trip switch indicates that the circuit breaker has tripped due to overload, ground fault, or short circuit and returns to the deenergized state when the circuit breaker is reset.

Shunt Trip, 12 VDC or 24 VDC

A shunt trip option provides a solenoid within the circuit breaker case that, when momentarily energized from a remote source, activates the trip mechanism. This feature allows the circuit breaker to be tripped by customer-selected faults such as alternator overload or overspeed. The circuit breaker must be reset locally after being tripped. Tripping has priority over manual or motor operator closing.

Shunt Trip Wiring

Connects the shunt trip to the generator set controller. (standard on KD models with the APM802 controller)

Undervoltage Trip, 12 VDC or 24 VDC

The undervoltage trips the circuit breaker when the control voltage drops below the preset threshold of 35%- 70% of the rated voltage.

15- 300* kW Line Circuit Breaker Specifications

* Includes models 300REOZJ and 300REZXC. For other 300 kW models, see the 300- 2250 kW section.

100% Rating Circuit Breaker

Alt. Model	Ampere Range	Trip Type	C. B. Frame Size		
4D/4E	15- 150	Thermal magnetic	HD		
		Electronic LI			
		Electronic LSI			
	60- 150	Electronic LSI		HG	
		Electronic LSIG			
		Electronic LI			
4P/4PX 4Q/4QX	15- 150	Thermal magnetic	HD		
		Electronic LI			
		Electronic LSI			
	60- 150	Electronic LSI		HG	
		Electronic LSIG			
		Electronic LI			
	175- 250	Thermal magnetic	JD		
	250	Electronic LI	JD		
		Electronic LSI			
		Electronic LSIG			
	250	Electronic LI	JG		
		Electronic LSI			
		Electronic LSIG			
	400	Electronic LI	LG		
		Electronic LSI			
		Electronic LSIG			
	4RX 4S/4SX 4TX 4V 4UA 4M6226	15- 150	Thermal magnetic	HD	
			Electronic LI		
			Electronic LSI		
		60- 150	Electronic LSI		HG
			Electronic LSIG		
			Electronic LI		
		175- 250	Thermal magnetic	JD	
			Electronic LI		
Electronic LSI					
250		Electronic LSI	JG		
		Electronic LSIG			
		Electronic LI			
400		Electronic LI	LG		
		Electronic LSI			
		Electronic LSIG			
600- 800		Electronic LSI	PG		
		Electronic LSIG			
4UA 4M6226		1000- 1200	Electronic LSI	PG	
	Electronic LSIG				
	1200	Electronic LSI	PJ		
		Electronic LSIG			

100% Rating Electrically Operated Breakers

For use as paralleling breakers with the Decision-Maker® 6000 Controller/DPS System or APM603 controller.

Generator-Mounted P-Frame, 24VDC Electrically Operated			
Alt. Model	Amps	Trip Unit	Frame
4RX 4S/4SX 4TX 4V	250	3.0 LI	PJ
	400	5.0 LSI	PJ
	600	3.0 LI	PL
	800	5.0 LSI	PL
4UA 4M6226	250	3.0 LI	PJ
	400	5.0 LSI	PJ
	600	3.0 LI	PL
	800	5.0 LSI	PL
	1000	3.0 LI	PL
	1200	5.0 LSI	PL

All circuit breakers listed in this table include line side bus and load side lugs, 24VDC motor operators, 2 type C auxiliary contacts, and 1 type C SDE overcurrent switch contact. No second breakers are allowed in combination with these breakers.

Interrupting Ratings

Circuit Breaker Frame Size	240 Volt, kA	480 Volt, kA	600 Volt, kA
HD	25	18	14
HG	65	35	18
HJ	100	65	25
JD	25	18	14
JG	65	35	18
JJ	100	65	25
LA	42	30	22
LG	65	35	18
MG			
PG	65	35	18
PJ	100	65	25
PL	125	100	25

Circuit Breaker Lugs Per Phase (Al/Cu)

Frame Size	Ampere Range	Wire Range
E (480 V max.)	30- 100	Up to two wire terminals fitting 10-32 or 1/4-20 stud
H	15- 150	One #14 to 3/0
	175	One 1/0 to 4/0
J	200- 250	One 3/0 to 350 kcmil
LA	300- 400	One #1 to 600 kcmil or Two #1 to 250 kcmil
LG	400- 600	Two 2/0 to 500 kcmil AL/CU
M	800	Three 3/0 to 500 kcmil
	600-800	Three 3/0 to 500 kcmil
P	1000-1200	Four 3/0 to 500 kcmil
Mechanical Load Lugs Included with H, J, and LG LSIG Neutrals		
H	60- 150	One #14 to 3/0 AL/CU
J	250	One 3/0 to 350 kcmil AL/CU
LG	400- 600	Two 4/0 to 500 kcmil AL/CU

15- 300* kW Line Circuit Breaker Applications

* Includes models 300REOZJ and 300REZXC. For other 300 kW models, see the 300- 2250 kW section.

Single Circuit Breaker Installations

A generator set with a single circuit breaker installed typically feeds a single transfer switch and then a distribution panel. This allows protection of the entire system.

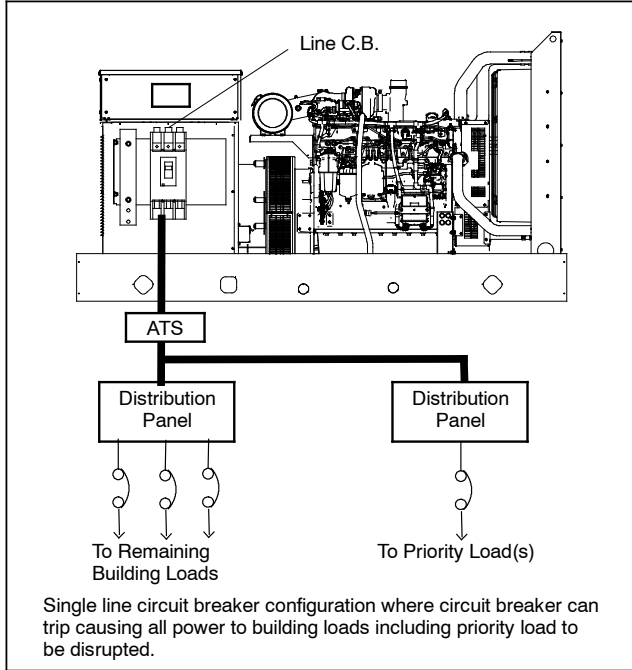

Multiple Circuit Breaker Installations

A generator set with dual circuit breakers installed is used to separate critical loads. Typically, one circuit breaker will feed a main transfer switch with noncritical loads and the other circuit breaker will feed a second transfer switch that feeds critical or priority loads. Multiple circuit breakers allow circuit protection for special applications.

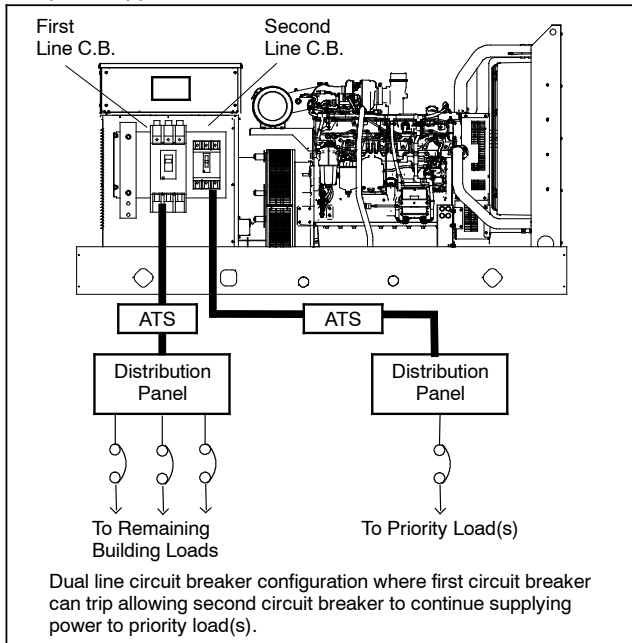

Circuit Breaker Combinations

Alternator Model	First C. B. Frame	Second C. B. Frame	Third C. B. Frame	Trip Type
ALL except 4D/4E	H	—	—	All
	J	—	—	
	LA	—	—	
	LG	—	—	
4D/4E	H	—	—	Standard or LSIG
	H	H	—	No LSIG
4P/4PX 4Q/4QX	H	H or J	—	No LSIG
	J		—	
	LA	—		
	LG	H, J or LG	—	
4RX 4S/4SX 4TX 4V	M	—	—	All
	P	—	—	All
	H or J	H or J	—	No LSIG
	LA	H, J, or LA	—	
	LG	H, J, LA, or LG	—	
	M		—	
	P	—	—	
H or J	H or J	H or J		
4UA 4M6226	M or P	—	—	All
	H or J	H or J	—	All
	LA	H, J, or LA	—	
	LG	H, J, LA, or LG	—	
	M or P	H, J, LA, or LG	—	
	P	P	—	
	H or J	H or J	H or J	
	LA	H or J	H or J	
		LA	H, J, or LA	
	LG	H or J	H or J	
LA		H, J, or LA		
M or P	LA	H, J, or LA		
	LG	H, J, or LG		

MULTIPLES OF RATED CURRENT

JD, JG, JJ, JL MOLDED CASE CIRCUIT BREAKERS
CHARACTERISTIC TRIP CURVE NO. 50-5

CIRCUIT BREAKER INFORMATION

Circuit Breaker Prefix	Continuous Ampere Rating	Maximum AC Voltage	Number of Poles
JD, JG, JJ, JL	150-250	600	2, 3

This curve is to be used for application and coordination purposes only. The EZ-AMP overlay feature at the bottom of the page should be used during coordination studies.

All time/current characteristic curve data is based on 40°C ambient cold start. Terminations are made with conductors of appropriate length and ratings.

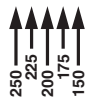
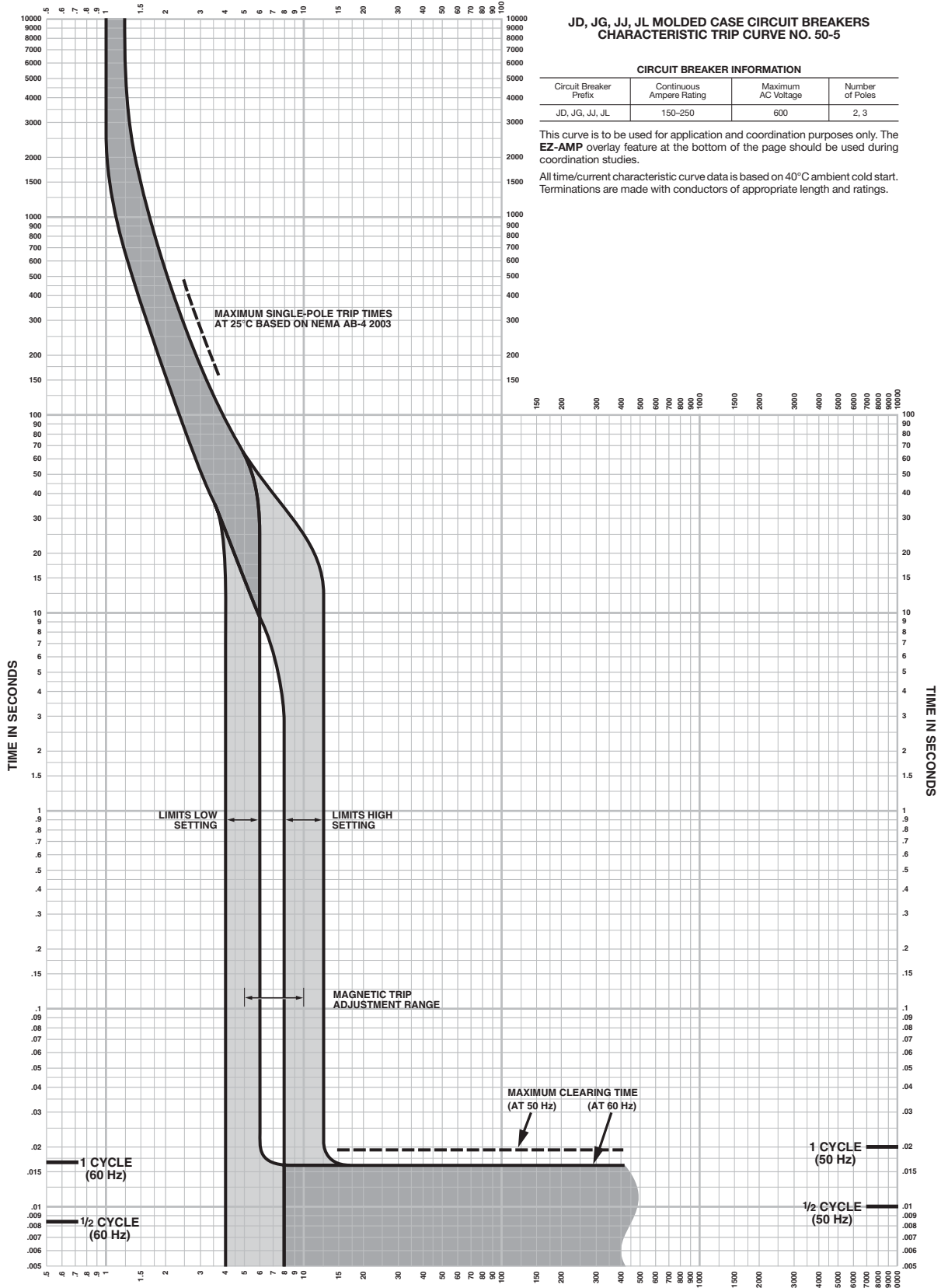

MULTIPLES OF RATED CURRENT

EZ-AMP™



Typical Overall Dimensions

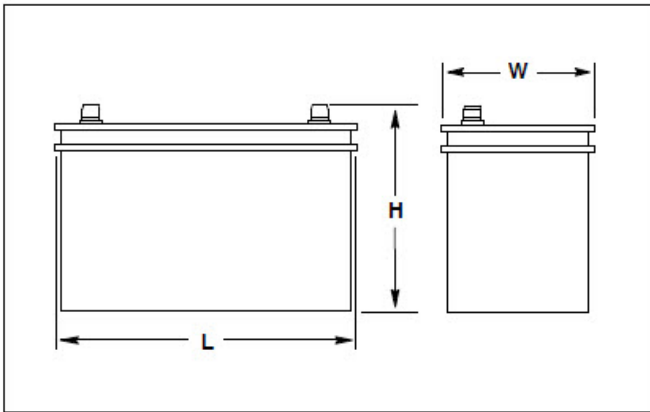

Standard Features

- Kohler Co. selects batteries to meet the engine manufacturer's specifications and to comply with NFPA requirements for engine-cranking cycles.
- Heavy-duty starting batteries are the most cost-effective means of engine cranking and provide excellent reliability in generator set applications.
- Tough polypropylene cases protect against life-shortening vibration and impact damage.
- Batteries are rated according to SAE standard J-537.
- All batteries are 12-volts. Kits that contain two or four batteries are available for 24-volt systems and/or systems with redundant starters.
- Wet- and dry-charged batteries have lead-calcium or lead-antimony plates and use sulfuric acid electrolyte. Removable cell covers allow checking of electrolyte specific gravity.
- Absorbant glass mat (AGM) batteries are sealed and maintenance free.
- Batteries are for applications below and above 0 ° C (32 ° F).

Charge Type*	Battery Part Number	Battery Qty. per Size	BCI Group Size	Battery SAE Dimension, mm (in.)			Cold Cranking Amps at 18°C (0°F) Min.	Reserve Capacity Minutes at 27° (80°F) Min.	Battery Post Layout and Style
				L	W	H			
Wet	256984	1	24	273.0 (10.8)	173.0 (6.8)	228.6 (9.0)	650	130	D/1

Battery Specifications

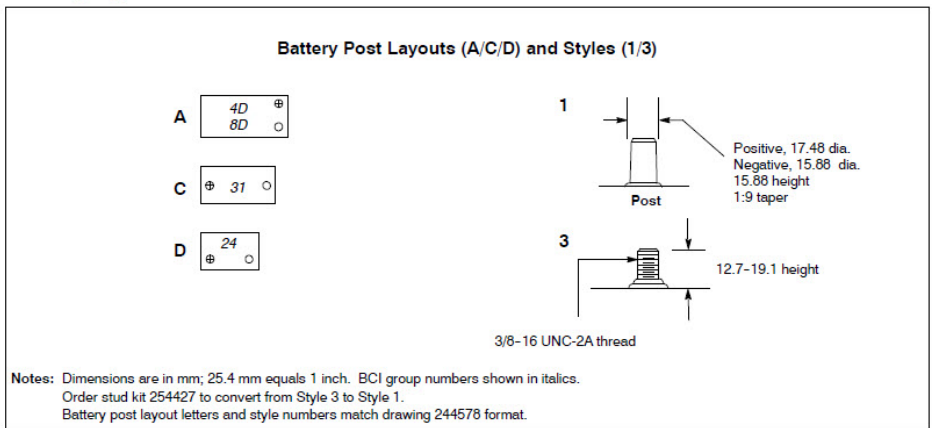

12/24 Volt, 10 Amp

Automatic Multi-Stage Battery Charger

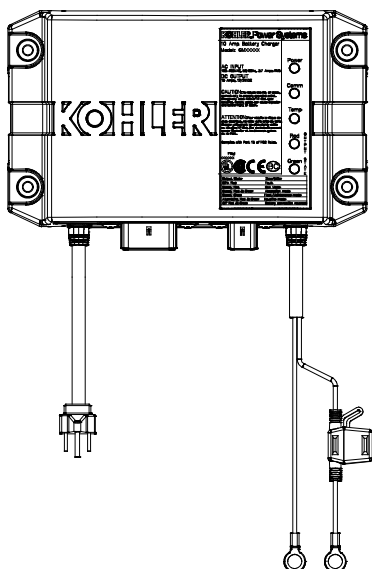

The battery charger is a fully-automatic, high efficiency battery charger that charges batteries rapidly and safely. The battery charger is designed for an industrial environment.

The battery charger is designed for operation with an engine cranking battery.

The battery charger is universal voltage input capable, comes with a standard 120 V/60 Hz AC plug, and charges 12 VDC or 24 VDC battery systems.

Five LED lights indicate power, communication status, temperature compensation status, charge curve, and charger status.

With the optional battery temperature sensor connected, the battery charger can adjust output voltages for optimal charging.

Standard Features

- 12 or 24 VDC output
 - Automatic voltage detection
- Automatic multi-stage charging modes
 - Recovery charge
 - Bulk charge
 - Absorption charge
 - Float charge
 - Equalize charge
- Charges the following type batteries:
 - Flooded lead acid (FLA)
 - AGM
 - Gel cell
 - High performance AGM
 - Nickel-cadmium (NiCad)
- 5 LED status indicators
- Durable potted assembly for waterproofing and vibration resistance
- Reverse-polarity protection
- Short-circuit protection
- Electronically limited output current
- Optional temperature compensation (FLA only)
- User adjustable parameters to support optimal manufacturer recommended charge curve.
- Code compliance:
 - UL 1236 Listed
 - NFPA 110, Level 1 compatible (when used with Kohler controller and connected to engine harness)
 - CSA - C22.2 No. 107.2-01
 - FCC - Title 47, Part 15 Class A
 - CE
 - IBC 2015
 - OSHPD

DC Output		AC Input		Overall Dimensions W x D x H	Shipping Weight	
Volts (Nominal)	Amps	Volts (Nominal)	Amps		kgs	lbs
12/24	10	100-260	3.7	253 mm x 152 mm x 74 mm (10.0 in x 6.0 in x 2.9 in)	3.6	7.9



KOHLER CO., Kohler, Wisconsin 53044 USA
 Phone 920-457-4441, Fax 920-459-1646
 For the nearest sales and service outlet in the
 US and Canada, phone 1-800-544-2444
 KOHLERPower.com

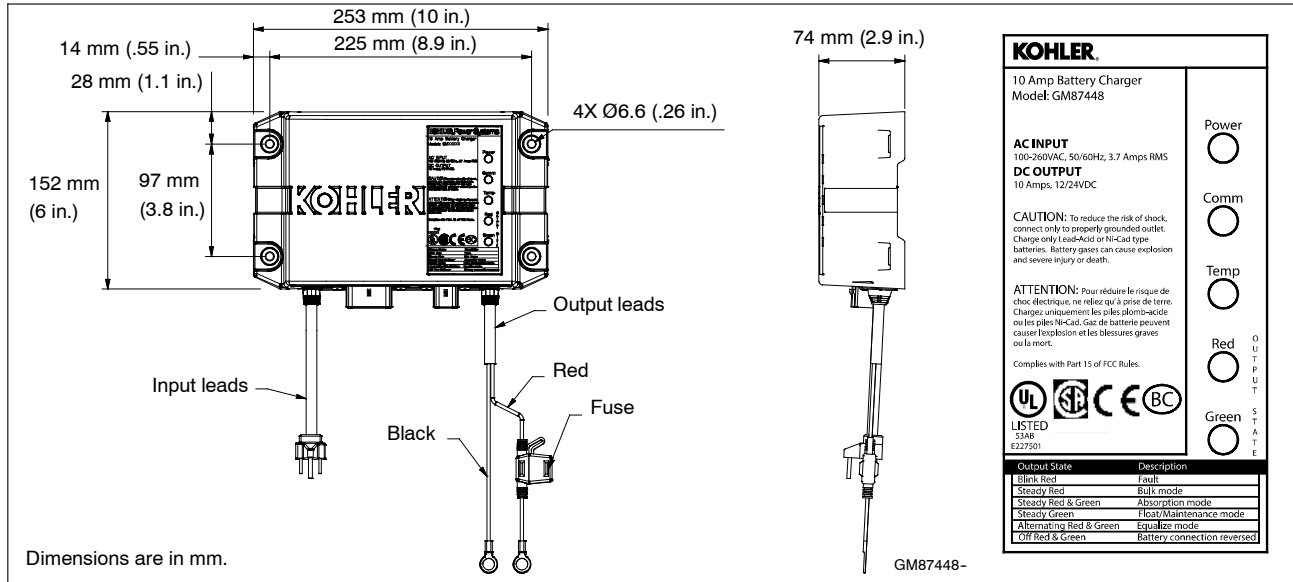

Specifications

AC Input	100-260 VAC
Frequency Input	50/60 Hz
DC Output	10 Amps @ 12 VDC or 10 Amps @ 24 VDC (On battery voltage regulation $\pm 1\%$; current is electronically limited)
Fuse Protection	15 amps ATC
Battery Types	Flooded Lead Acid (FLA) AGM Gel Cell High Performance AGM Nickel-Cadmium (NiCad)
Monitoring LED Indications	Power Communication Temperature compensation Output charger curve and charger status: <ul style="list-style-type: none"> ○ Red ○ Green
Environmental	
Operating	-20° to 70°C (-4° to 158° F)
Storage	-40° to 85°C (-40° to 185° F)
Relative Humidity	5 to 95% (non-condensing)
Salt Spray Testing	ASTM B117
Corrosion Resistant	From battery gases

Enclosure	
Environmental Resistant	From rain, snow, dust, and dripping water
Battery Connections	
Lead Length	1.8 m (6 ft.) red and black leads
Battery Connections	9.5 mm (3/8 in.) ring terminals
AC Power Connections	
Lead Length	1.8 m (6 ft.)
Storage	Standard US style 3-prong AC plug
Available Options	Temperature compensation

DISTRIBUTED BY:

Availability is subject to change without notice. Kohler Co. reserves the right to change the design or specifications without notice and without any obligation or liability whatsoever. Contact your local Kohler® generator distributor for availability.

© 2017, 2019 by Kohler Co. All rights reserved.



Sound Enclosure Standard Features

- Internal-mounted silencer and flexible exhaust connector.
- Lift base or tank-mounted, steel construction with hinged doors on the service side and easily removeable panels on the non-service side.
- Fade-, scratch-, and corrosion-resistant Kohler Power Armor cream beige automotive-grade textured finish.
- Enclosure has four large access doors/panels which allow for easy maintenance.
- Lockable, flush-mounted door latches.
- Horizontal air inlet and vertical outlet discharge to redirect air and redirect noise.
- Acoustic insulation that meets UL 94 HF1 flammability classification and repels moisture adsorption.
- Sound attenuated enclosure that uses up to 51 mm (2 in.) of acoustic insulation.

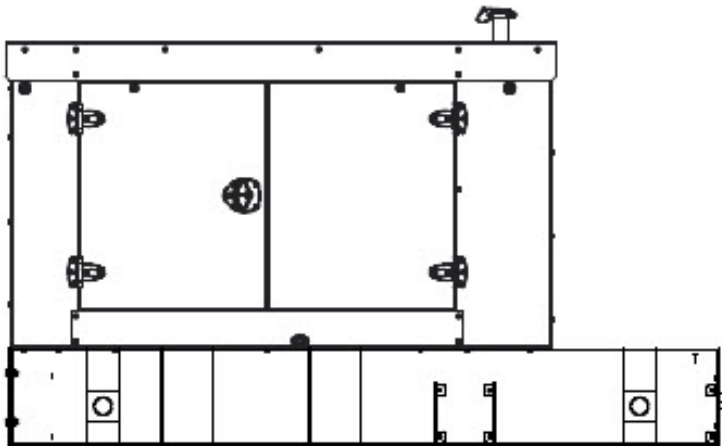

Enclosure with State Code Subbase Fuel Tank

Subbase Fuel Tank Features

- The fuel tank has a Power Armor Plus textured epoxy-based rubberized coating.
- The above-ground rectangular secondary containment tank mounts directly to the generator set, below the generator set skid (subbase).
- Both the inner and outer tanks have emergency relief vents.
- Flexible fuel lines are provided with subbase fuel tank selection.
- The secondary containment tanks construction protects against fuel leaks or ruptures. The inner (primary) tank is sealed inside the outer (secondary) tank. The outer tank contains the fuel if the inner tank leaks or ruptures.
- State tanks with varying capacities are an available option. Florida Dept. of Environmental Protection (FDEP) File No. EQ-634 approved.

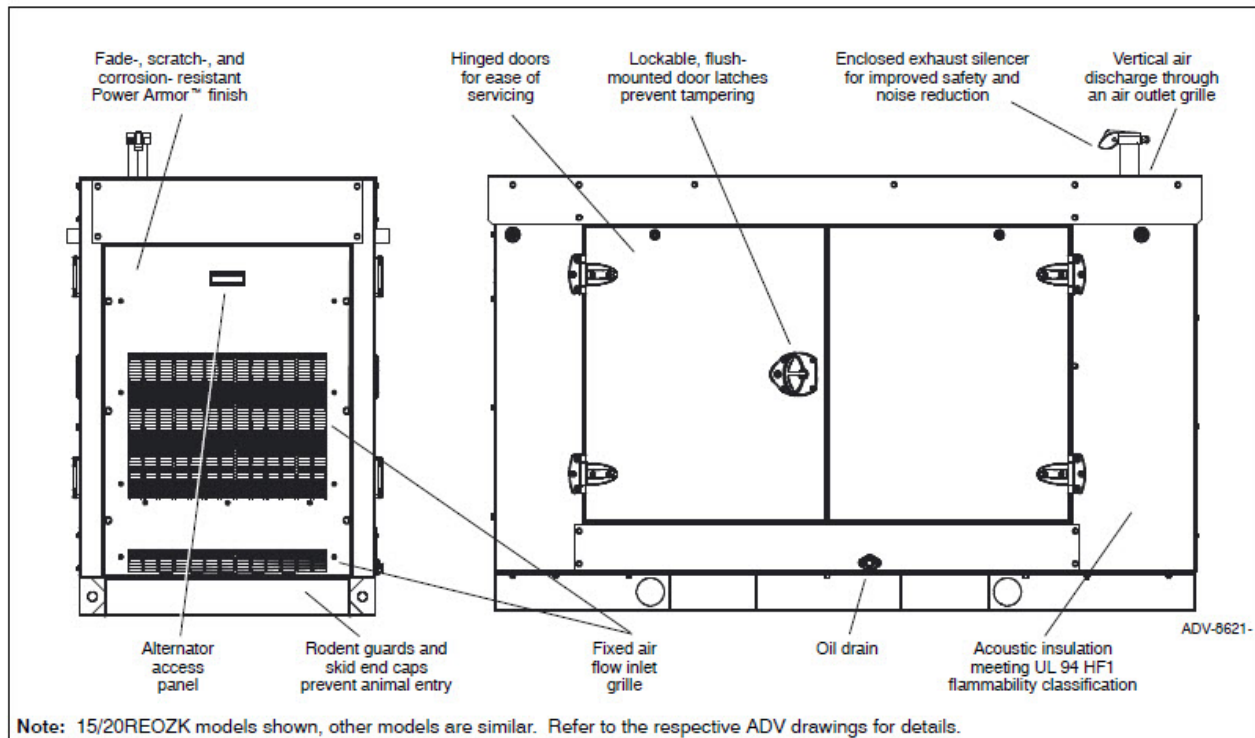

Sound Enclosure Features

- Available in steel (14 gauge) formed panel, solid construction. Preassembled package offering corrosion resistant, dent resilient structure that mounts directly to lift base or fuel tank.
- Power Armor automotive-grade finish resulting in advanced corrosion and abrasion protection as well as enhanced edge coverage and colored retention.
- Internal exhaust silencer offering maximum component life and operator safety.
- Note: Installing an additional length of exhaust tail pipe may increase backpressure levels. Please refer to the generator set spec sheet for the maximum backpressure value.
- Interchangeable modular panel construction. Allows complete serviceability or replacement without compromising enclosure design.
- Cooling/combustion air intake with a horizontal air inlet. Sized for maximum cooling airflow.
- Service access. Multi-personnel doors/panels for easy access to generator set control and servicing of the fuel fill, fuel gauge, oil fill, and battery.
- Cooling air discharge. Weather protective design featuring vertical air discharge air outlet grille. Redirects cooling air up and above enclosure to reduce ambient noise. The sound enclosures include acoustic insulation with urethane film.
- Cooling air discharge. The sound enclosures include acoustic insulation with urethane film.

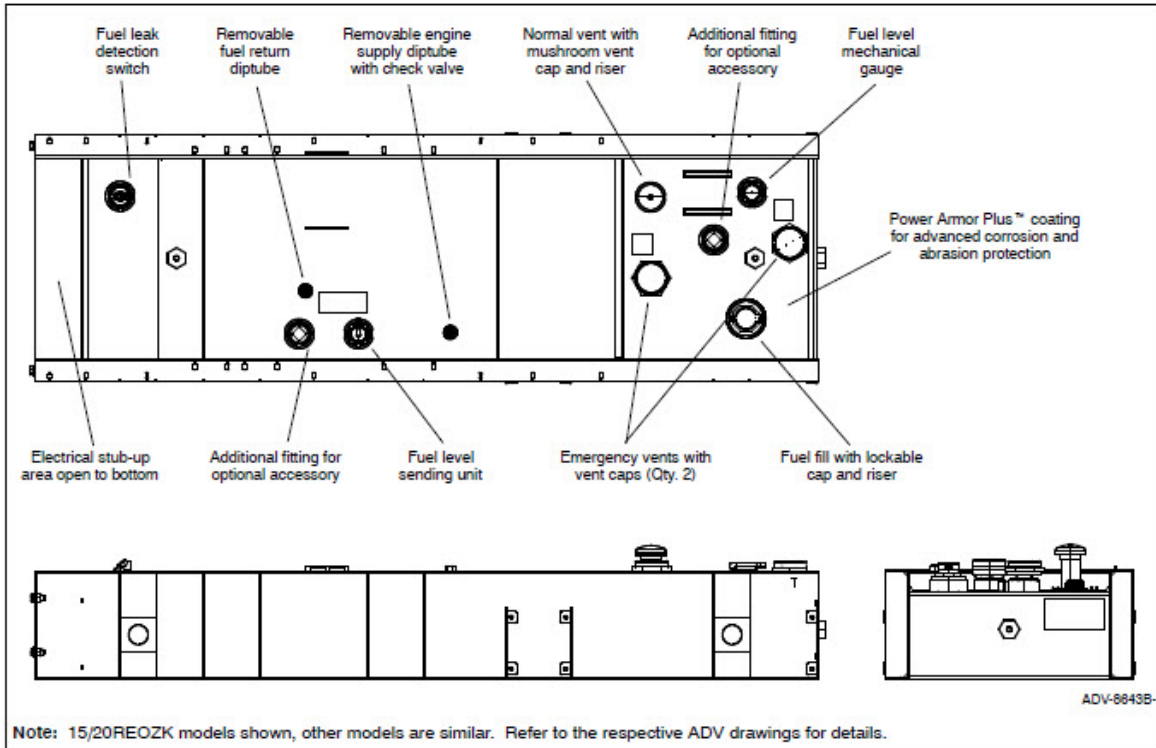

- Extended operation. Usable tank capacity for multiple hour requirements.
- Power Armor Plus textured epoxy-based rubberized coating that creates an ultra-thick barrier between the tank and harsh environmental conditions like humidity, saltwater, and extreme temperatures. Provides an advanced corrosion and abrasion protection.
- UL listed. Secondary containment generator set base tank meeting UL 142 tank requirements.
- NFPA compliant. Designed to comply with the installation standards of NFPA 30 and NFPA 37.
- Integral external lift lugs. Enables crane with spreader-bar lifting of the complete package (empty tank, mounted generator set, and enclosure) to ensure safety.
- Emergency pressure relief vents. Vents ensure adequate venting of inner and outer tank under extreme pressure and/or emergency conditions.
- Normal vent with cap and riser
- Leak detection switch. Annunciates a contained primary tank fuel leak condition at generator set control.
- Electrical stub-up.
- State tank designed to comply with the installation standards of the Florida Dept. of Environmental Protection (FDEP) File No. EQ-634.

Fuel Tank Capacity, L (gal.)	Est. Fuel Supply Hours at 60 Hz with Full Load	Enclosure and Fuel Tank Weight, kg (lb.)	Enclosure and Fuel Tank Height, mm (in.)	Fuel Tank Height (H), mm (in.)	Sound Pressure Level, dB(A)
541 (142)	24/31	1529 (3371)	1787 (70.4)	432 (17)	64

Note: Data in table is for reference only, refer to the respective ADV drawings for details. Refer to TIB-114 for generator set sound data.
 * Max. weight includes the generator set (wet) with largest alternator option, enclosure with acoustic insulation added, silencer, and tank (no fuel).
 State code fuel tank specifications (height and weight) do not include I-beam option. Width dimension shown includes rubber door stops.



Integral Voltage Regulator with Kohler® APM402/ Decision-Maker® 3000 and Menu-Driven Selections (15-1000 kW Generator Set Models)

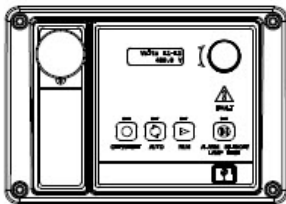

APM402 and Decision-Maker® 3000 Controller with Integral Voltage Regulator

The voltage regulator is integral to the controller and uses patented hybrid voltage regulator design providing ±0.5% no-load to full-load regulation using root-mean-square (RMS) voltage sensing. The voltage regulator features three-phase sensing and is available for 12- or 24-volt engine electrical systems.

Voltage Regulators

The following information provides general features, specifications, and functions of available voltage regulators.

This information generally applies to a single generator set and multiple generator sets with paralleling applications. Refer to the respective generator set specification sheet and see your authorized distributor for information regarding specific voltage regulator applications and availability.

Integral Voltage Regulators with APM402/Decision-Maker® 3000 Controllers

Calibration	Digital Display	Range Settings	Default Selection
Voltage Adjustment	Volt Adj	± 10% of System Voltage	System Voltage
Underfrequency Unload or Frequency Setpoint	Frequency Setpoint	42 to 62 Hz	2.5 Hz Below Nominal Frequency
Underfrequency Unload Scope	Slope	0-10% of System Voltage (Volts per Cycle)	5% of System Voltage



Specification/Feature	Integral with APM402/Decision-Maker® 3000
Generator Set Availability	15-1000 kW
Type	Patented Hybrid Design
Status and Shutdown Indicators	LEDs and Text LCD Display
Operating Temperature	-40 ° C to 70 ° C (-40 ° F to 158 ° F)
Storage Temperature	-40 ° C to 85 ° C (-40 ° F to 185 ° F)
Humidity	5-95% Non-Condensing
Circuit Protection	Solid-State, Redundant Software and Fuses
Sensing, Nominal	100-240 Volts (L-L), 50-60 Hz
Sensing Mode	RMS, Single- or 3-Phase
Input Requirements	8-36 VDC
Continuous Output	5 VDC @ 100mA max. 5.0 ADC with GM88453 Activator Board
Maximum Output	5 VDC @ 100mA max. 5.0 ADC with GM88453 Activator Board
Transition Frequency	42.0-62.0Hz
Exciter Field Resistance	4-30 Ohms with GM88453 Activator Board
No-Load to Full-Load Voltage Regulation	± 0.5%
Thermal Drift	<0.5% (-40 ° C to 70 ° C) [-40 ° F to 158 ° F] Range
Response Time	Less than 5µS
System Voltage Adjust.	± 10%
Voltage Adjustment	Controller Menu Knob
Remote Voltage Adjustment	not available
Paralleling Capability	not available
VAR/PF Control Input	not available

Integral Voltage Regulator with APM402/Decision-Maker® 3000 Controller

- The APM402/Decision-Maker® 3000 digital display and pushbutton/rotary dial provide access to data. A two-line LCD display provides complete and concise information. A two-line vacuum fluorescent display provides complete and concise information.
- The Decision-Maker® 3000 graphical display and pushbutton/rotary dial provide access to data. A five-line, 35-characters per line LCD display provides complete and concise information include gain, ramp rate, reactive droop, VAR control (P, I, D gains) and PF control (P, I, D gains).
- The controllers provide ISO 8528-5, Class G3, compliance for transient response on some 20-300 kW generator set models. Both controllers support Modbus®.
- These controllers can control Fast Response™ II, Fast Response™ X, and wound field alternators using the GM88453 activator board.

Voltage Regulator Menu

- Voltage adjustment, ± 10% of system voltage
- V/Hz cut-in, 42-62 Hz
- Underfrequency unload slope, 0-10% of system voltage

Jumpers

- L1-L2 volts
- L2-L3 volts (3-phase)
- L3-L1 volts (3-phase)
- L1-N volts
- L2-N volts
- L3-N volts (3-phase)

KOHLER®

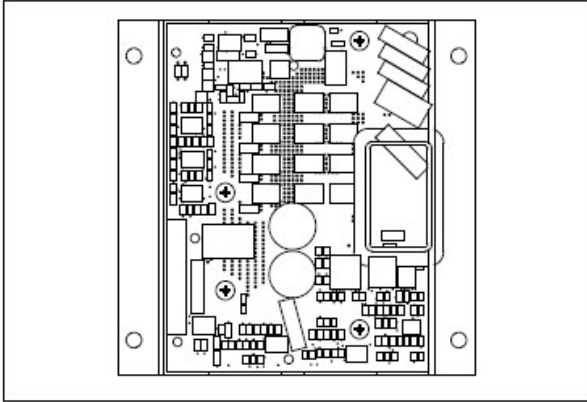

- Interfaces between the controller and alternator assembly using rotor field leads, auxiliary power windings, and optic board leads.
- Allows the Decision-Maker® controllers the ability to control a wound-field alternator using the same control signal as Fast Response™ alternator.
- Permits the generator set controller to control the current to the exciter field of a wound-field excited alternator.
- Contains two isolated relay driver outputs (RDO) rated at 250 mA. Provides RDO outputs indicating a field over-excitation condition and that the alternator is supplying voltage to the activator.

Modbus® is a registered trademark of Schneider Electric.

Remote Serial Annunciator III (RSA III)

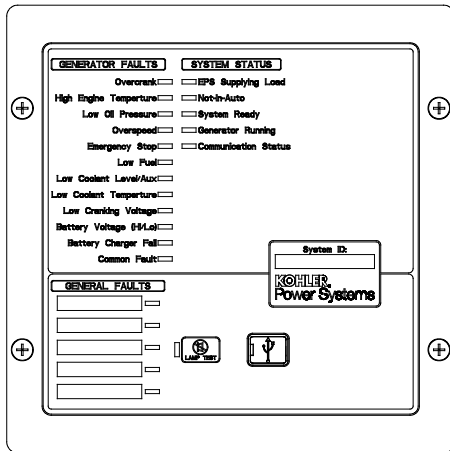

RSA III

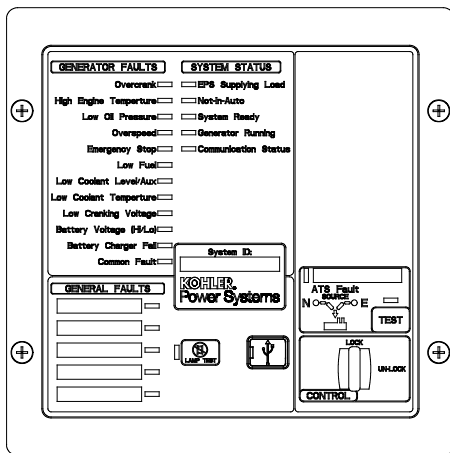

RSA III with a Single ATS Control

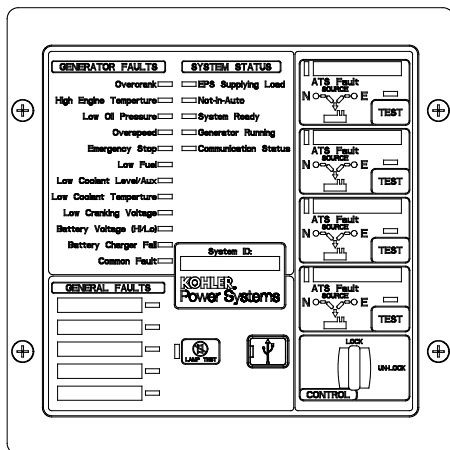

RSA III with Four ATS Controls

Remote Serial Annunciator III (RSA III) for Kohler® Controllers

- Monitors the generator set equipped with one of the following controllers:

APM402	Decision-Maker® 3000
APM603	Decision-Maker® 3500
APM802	Decision-Maker® 6000
Decision-Maker® 3+	Decision-Maker® 8000
Decision-Maker® 550	KPC 1000
- Allows monitoring of the common alarm, remote testing of the automatic transfer switch, and monitoring of the normal/emergency source for up to four ATS with any of the following controllers:

Decision-Maker®	MPAC® 750, 1200, and 1500
MPAC®	1000 and 1500
- Configuration via a personal computer (PC) software.
- Writable surfaces (white boxes in illustrations) for user-defined selections.
- Uses Modbus® RTU protocol.
- Controller connections:
 - RS-485 for serial bus network
 - USB port. Connect a personal computer and use Kohler® SiteTech™ software to view events and adjust settings. *
 - 12-/24-volt DC power supply
 - 120/208 VAC power supply (available accessory)
- Meets the National Fire Protection Association Standard NFPA 110, Level 1.

Dimensions

- Dimensions—W x H x D, mm (in.).

Surface Mounted:

203 x 203 x 83 (8.0 x 8.0 x 3.3)

Flush Mounted (Inside Wall):

203 x 203 x 76 (8.0 x 8.0 x 3.0)

Flush mounting plate W1: 254 (10.0)

* SiteTech™ software is available to Kohler authorized distributors and dealers.

Modbus® is a registered trademark of Schneider Electric.

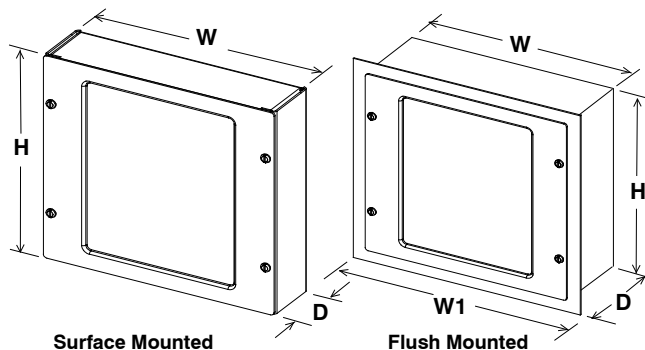

Fault and Status Conditions	Fault LEDs	Fault Horn	System Ready LED	Generator Running LED	Communication Status LED
Overcrank Shutdown	Red	On	Red	Off	Green
High Engine Temperature Warning *	Yellow	On	Red	Green	Green
High Engine Temperature Shutdown	Red	On	Red	Off	Green
Low Oil Pressure Warning *	Yellow	On	Red	Green	Green
Low Oil Pressure Shutdown	Red	On	Red	Off	Green
Overspeed Shutdown	Red	On	Red	Off	Green
Emergency Stop *	Red	On	Red	Off	Green
Low Coolant Level/Aux. Shutdown	Red	On	Red	Off	Green
Low Coolant Temperature *	Yellow	On	Red	Off	Green
Low Cranking Voltage	Yellow	On	Red	Off	Green
Low Fuel—Level or Pressure *	Yellow	On	Red	Green or Off	Green
Not-In-Auto	Red	On	Red	Green or Off	Green
Common Fault	Red	On	Green	Green or Off	Green
Battery Charger Fault (1) *	Yellow	On	Red	Green or Off	Green
Battery Charger Fault (2) *	Yellow	On	Green	Green or Off	Green
High Battery Voltage *	Yellow	Off	Green	Green or Off	Green
Low Battery Voltage *	Yellow	Off	Green	Green or Off	Green
User Input #1 (Warning)	Yellow	Off	Green	Green or Off	Green
User Input #1 (Shutdown)	Red	On	Green	Off	Green
User Input #2 (Warning)	Yellow	Off	Green	Green or Off	Green
User Input #2 (Shutdown)	Red	On	Green	Off	Green
User Input #3 (Warning) (1) †	Yellow	Off	Green	Green or Off	Green
User Input #3 (Shutdown) (1) †	Red	On	Green	Off	Green
User Input #4 (Warning) (1)	Yellow	Off	Green	Green or Off	Green
User Input #4 (Shutdown) (1)	Red	On	Green	Off	Green
User Input #5 (Warning) (1)	Yellow	Off	Green	Green or Off	Green
User Input #5 (Shutdown) (1)	Red	On	Green	Off	Green
EPS Supplying Load	Yellow	Off	Green	Green	Green
Communications Status (Fault mode)	—	Off	Green or Red	Green or Off	Red
ATS Fault (RSA III with ATS Controls only)	Red	On	Red or Yellow	Green or Off	Green

Green LEDs appear as steady on when activated.

Yellow LEDs slow flash when activated except steady on with EPS supplying load and high battery voltage.

Red LEDs slow flash when activated except fast flash with loss of communication and not-in-auto.

Specifications

- LED indicating lights for status, warning, and/or shutdown.
- Power source with circuit protection: 12- or 24-volt DC
- Power source with 120/208 VAC, 50/60 Hz adapter (option)
- Power draw: 200 mA
- Humidity range: 0% to 95% noncondensing
- Operating temperature range: -20°C to +70°C (-4°F to +158°F)
- Storage temperature range: -40°C to +85°C (-40°F to +185°F)
- Standards:
 - NFPA 110, level 1
 - UL 508 recognized
 - CE directive
 - NFPA 99
 - ENS 61000-4-4
 - EN611-4-4 fast transient immunity
- RS-485 Modbus® isolated port @ 9.6/19.2/38.4/57.6 kbps (default is 19.2 kbps)
- USB device port
- NEMA 1 enclosure

(1) All generator set controllers except Decision-Maker® 3+ controller.

(2) Decision-Maker® 3+ controller only.

* May require optional kit or user-provided device to enable function and LED indication.

† Digital input #3 is factory-set for high battery voltage on the Decision-Maker® 3+ controller.

Modbus® is a registered trademark of Schneider Electric.

NFPA Requirements

- NFPA 110 compliant
- Engine functions:
 - High battery voltage warning *
 - High engine temperature shutdown
 - High engine temperature warning *
 - Low battery voltage warning *
 - Low coolant level/aux. shutdown
 - Low coolant temperature warning *
 - Low cranking voltage
 - Low fuel warning (level or pressure) *
 - Low oil pressure shutdown
 - Low oil pressure warning *
 - Overcrank shutdown
 - Overspeed shutdown
- General functions:
 - Audible alarm silence
 - Battery charger fault *
 - Lamp test
 - Master switch not-in-auto

Fault and Status LEDs and Lamp Test Switch

Alarm Horn. Horn sounds giving a minimum 90 dB at 0.1 m (0.3 ft.) audible alarm when a warning or shutdown fault condition exists except on high/low battery voltage or EPS supplying load.

Alarm Silenced. Red LED on lamp test switch lights when alarm horn is deactivated by alarm silence switch.

Alarm Silence Switch. Lamp test switch quiets the alarm during servicing. The horn will reactivate upon additional faults.

ATS Fault. Red LED lights when ATS fails to transfer.

Battery Charger Fail. LED lights if battery charger malfunctions. Requires battery charger with alarm contact.

Battery Voltage Hi/Lo. LED flashes if battery or charging voltage drops below preset level. LED lights steady if battery voltage exceeds preset level.

Common Fault. LED lights when a single or multiple common faults occur.

Communication Status. Green LED lights indicating annunciator communications functional. Red LED indicates communication fault.

EPS Supplying Load. LED lights when the Emergency Power System (EPS) generator set is supplying the load (APM402, APM603, APM802, and Decision-Maker® 550, 3000, 3500, 6000, and 8000 controllers) or when transfer switch is in the emergency position (Decision-Maker® 3+ controller).

Emergency Stop. LED lights and engine stops when emergency stop is made. May require a local emergency stop switch on some Decision-Maker® 3+ controllers.

Generator Running. LED lights when generator set is in operation.

High Engine Temperature. Red LED lights if engine has shut down because of high engine coolant temperature. Yellow LED lights if engine coolant temperature approaches shutdown range. Requires warning sender on some models.

Lamp Test (Switch). Switch tests all the annunciator indicator LEDs and horn.

Low Coolant Level/Aux. LED lights when engine coolant level is below acceptable range on radiator-mounted generator sets only. When used with a Decision-Maker® 3+ controller, the LED indicates low coolant level or an auxiliary fault shutdown. Requires user-supplied low coolant level switch on remote radiator models.

Low Coolant Temperature. LED lights if optional engine block heater malfunctions and/or engine coolant temperature is too low. Requires prealarm sender on some models.

Low Cranking Voltage. LED lights if battery voltage drops below preset level during engine cranking.

Low Fuel (Level or Pressure). LED lights if fuel level in tank approaches empty with diesel models or fuel pressure is low on gas models. Requires customer-supplied switch.

Low Oil Pressure. Red LED lights if generator set shuts down because of insufficient oil pressure. Yellow LED lights if engine oil pressure approaches shutdown range. Requires warning sender on some models.

Not In Auto. LED lights when the generator set controller is not set to automatic mode.

Overcrank. LED lights and cranking stops if engine does not start in either continuous cranking or cyclic cranking modes.

Overspeed. LED lights if generator set shuts down because of overspeed condition.

System Ready. Green LED lights when generator set master switch is in AUTO position and the system senses no faults. Red LED indicates system fault.

User-Defined Digital Inputs #1-#5. Monitors five digital auxiliary inputs (can be configured as warnings or shutdowns). User-defined digital inputs are selected via the RSA III master for local or remote (generator set or ATS). The user-defined digital input can be assigned via PC using SiteTech™ setup software.

KOHLER®

Alternator Data

TECHNICAL INFORMATION BULLETIN

Alternator Data Sheet

Alternator Model: 4P7BX
Frequency: 60 Hz
Speed: 1800 RPM
Leads: 12 (6 Lead, 600 Volt)

Voltage L-N/L-L	Phase	Power Factor	Connection	kW* (kVA)						
				Class B		Class F			Class H	
				80°C Continuous	90°C Lloyds	95°C ABS	105°C Continuous	130°C Standby	125°C Continuous	150°C Standby
139/240 277/480	3	0.8	Wye	47.5 (59.0)	51.0 (63.5)	52.0 (65.0)	54.5 (68.0)	60.0 (75.0)	58.5 (73.0)	61.5 (76.5)
127/220 254/440	3	0.8	Wye	47.0 (58.5)	49.5 (61.5)	50.5 (63.0)	52.0 (65.0)	57.5 (71.5)	56.0 (70.0)	59.5 (74.0)
120/208 240/416	3	0.8	Wye	45.5 (56.5)	47.0 (58.5)	48.0 (60.0)	49.5 (61.5)	54.5 (68.0)	53.5 (66.5)	57.0 (71.0)
110/190 220/380	3	0.8	Wye	41.5 (51.5)	42.5 (53.0)	43.5 (54.0)	45.0 (56.0)	49.5 (61.5)	48.5 (60.5)	52.0 (65.0)
120/240	3	0.8	Delta	45.5 (56.5)	47.0 (58.5)	48.0 (60.0)	49.5 (61.5)	54.5 (68.0)	53.5 (66.5)	57.0 (71.0)
120/240	1	1.0	Dogleg	38.0 (38.0)	39.5 (39.5)	40.0 (40.0)	41.5 (41.5)	44.5 (44.5)	44.0 (44.0)	46.5 (46.5)
120/240	1	0.8	Dogleg	28.5 (35.5)	30.0 (37.5)	30.5 (38.0)	31.5 (39.0)	34.0 (42.5)	33.5 (41.5)	35.5 (44.0)
347/600	3	0.8	Wye	47.0 (58.5)	49.5 (61.5)	50.5 (63.0)	52.0 (65.0)	57.5 (71.5)	56.0 (70.0)	59.5 (74.0)

* All data tested in accordance with IEEE Standard 115. Kohler Co. reserves the right to change the design or specifications without notice and without any obligation or liability whatsoever.

Submittal Data: 139/240 Volts, 0.8 PF, 1800 RPM, 60 Hz, 3 Phase, 130°C Rise

	Symbol	PerUnit	Ohms		Symbol	Value
Typical Cold Resistances				Typical Time Constants		
Phase Resistance		0.035	0.027	Armature Short Circuit	T _a	0.008 sec.
Rotor Resistance		7.439	5.714	Transient Short Circuit	T' _d	0.068 sec.
Typical Reactances				Transient Open Circuit	T' _{do}	0.702 sec.
Synchronous				Typical Field Current		
Direct	X _d	3.579	2.749	Full Load	I _{fFL}	17.9 amps
Quadrature	X _q	1.738	1.335	No Load	I _{fNL}	4.0 amps
Transient				Typical Short Circuit Ratio		0.277
Unsaturated	X' _{du}	0.392	0.301	Harmonic Distortion		
Saturated	X' _d	0.345	0.265	RMS Total Harmonic Distortion		3.27%
Subtransient				Max. Single Harmonic		5th
Direct	X'' _d	0.163	0.125	Deviation Factor (No Load, L-L)		<5%
Quadrature	X'' _q	0.148	0.114	Telephone Influence Factor		61.2
Negative Sequence	X ₂	0.155	0.119	Insulation Class		
Zero Sequence	X ₀	0.012	0.009	per NEMA MG1-1.66		H
				Phase Rotation		ABC

**4P7BX, 60 Hz, 139/240, 277/480 Volts, Wye
TYPICAL ALTERNATOR EFFICIENCY***

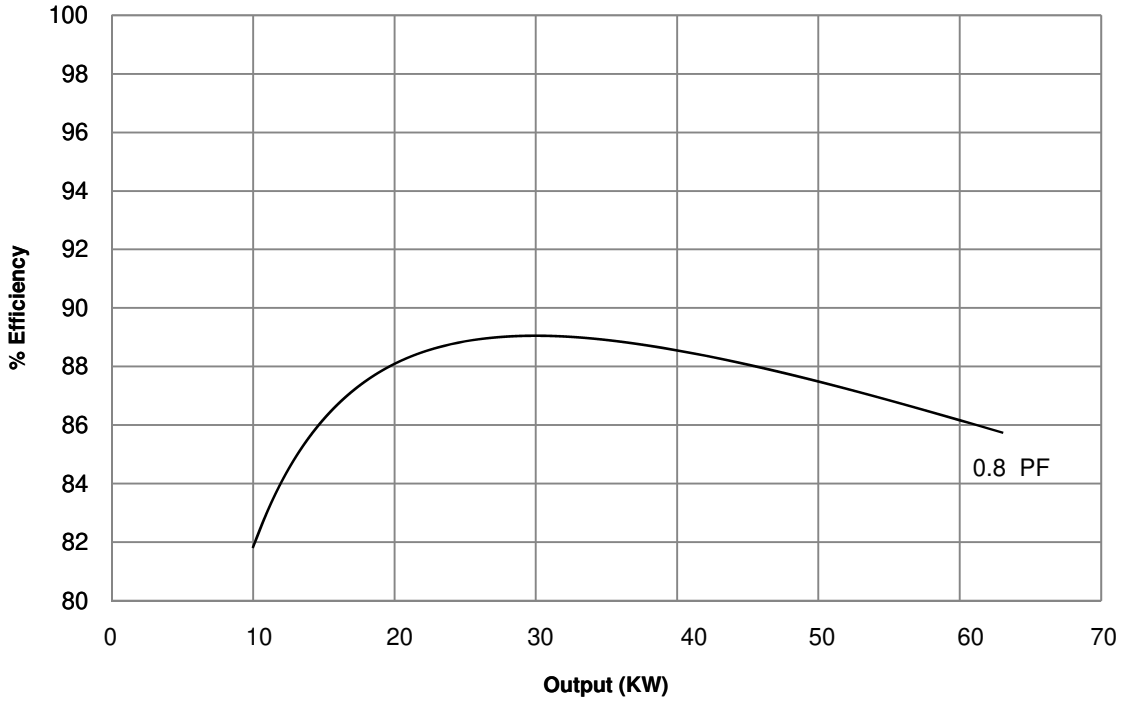

**4P7BX, 60 Hz, 139/240, 277/480 Volts, Wye
TYPICAL MOTOR STARTING CHARACTERISTICS***

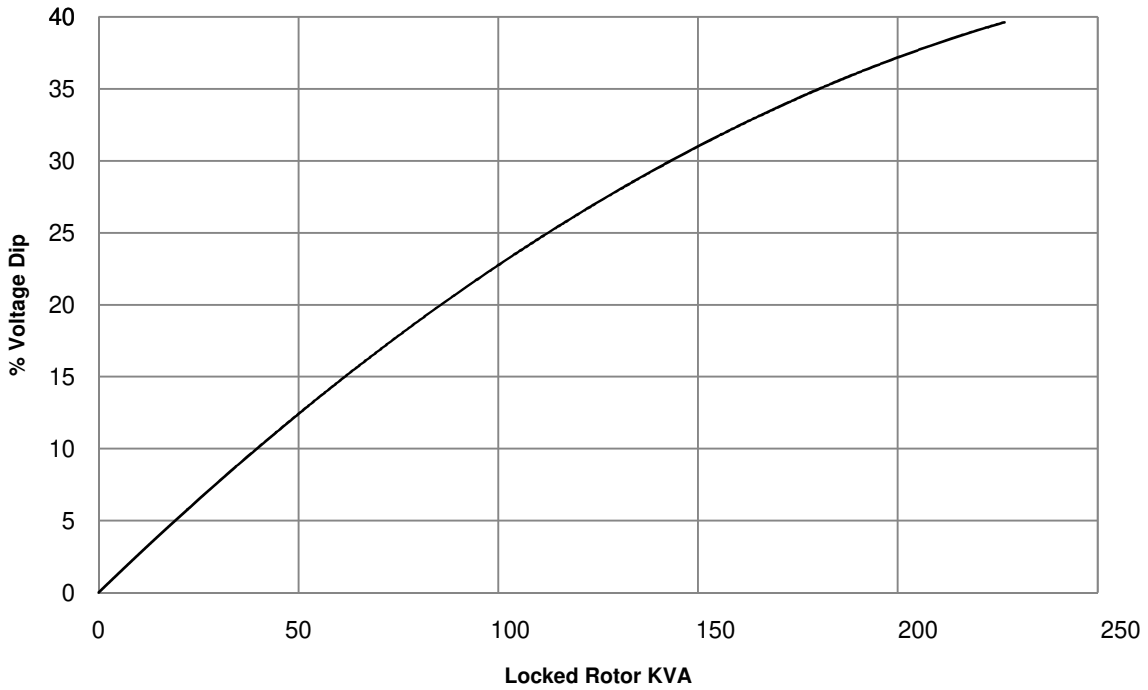

* All data tested in accordance with IEEE Standard 115. Kohler Co. reserves the right to change the design or specifications without notice and without any obligation or liability whatsoever.

**4P7BX, 60 Hz, Low Wye or Delta Connection
SHORT CIRCUIT DECREMENT CURVE**

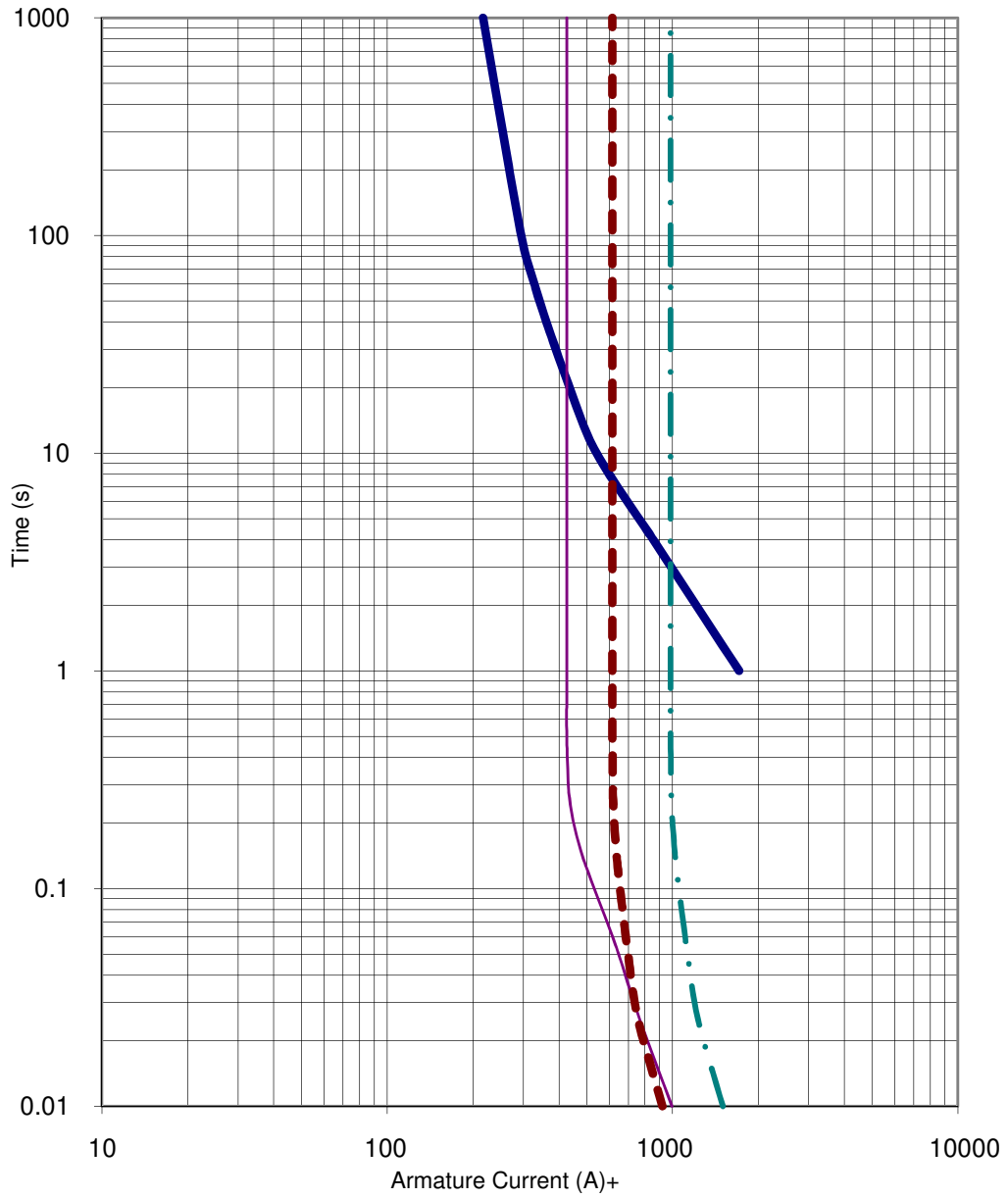

* Instantaneous current (t=0) is asymmetric. Divide by 1.73 for symmetric.

**4P7BX, 60 Hz, High Wye Connection
SHORT CIRCUIT DECREMENT CURVE**

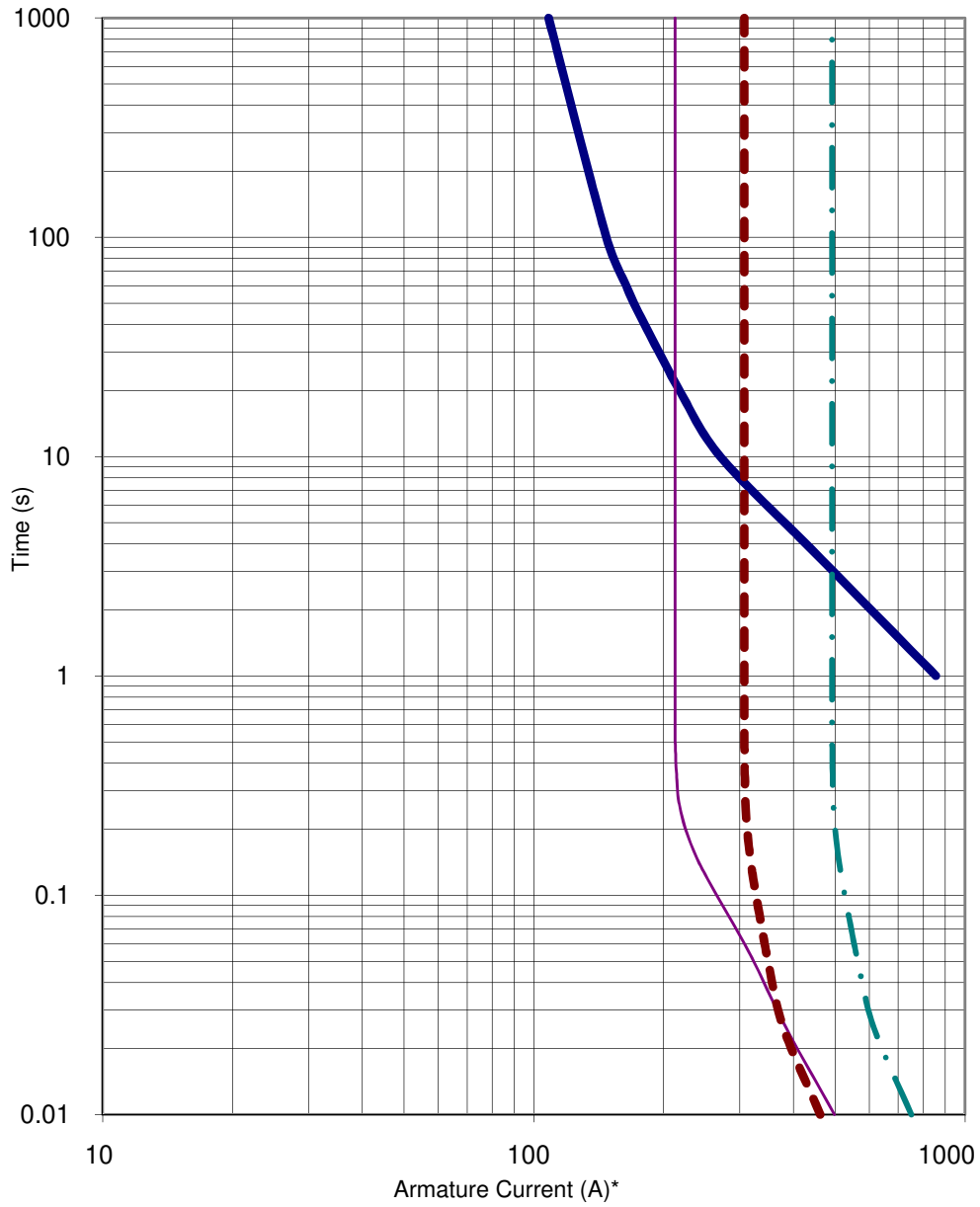

* Instantaneous current (t=0) is asymmetric. Divide by 1.73 for symmetric.

KOHLER®

Sound Data

TECHNICAL INFORMATION BULLETIN

Generator Set Sound Data Sheet

			Sound Pressure Data in dB(A)			
Generator Set Model	Hz	Load	Raw Exhaust	Open Unit, Isolated Exhaust	Weather Enclosure	Sound Enclosure
50REOZK	60	100% Load	103.1	81.6	79.7	64.6
		No Load	95.4	80.9	79.0	62.7

Note: Sound pressure data is the logarithmic average of eight perimeter measurement points at a distance of 7 m (23 ft.), except Raw Exhaust data which is a single measurement point at 1 m (3.3 ft.) from the mouth of a straight pipe exhaust.

50REOZK	60 Hz
----------------	--------------

			Sound Pressure Levels, dB(A)									
Load	Distance, m (ft)	Enclosure	Measurement Clock Position	Octave Band Center Frequency (Hz)								Overall Level
				63	125	250	500	1000	2000	4000	8000	
100% Load	7 (23)	Sound	3:00	49.2	54.3	58.6	56.1	54.7	57.5	52.0	49.1	64.1
			1:30	47.7	51.8	56.9	56.6	55.4	57.6	51.3	47.5	63.6
			12:00-Engine	47.4	51.3	60.4	59.2	57.1	57.6	51.9	48.5	65.4
			10:30	46.2	54.6	60.1	59.9	58.0	59.9	52.3	47.7	66.2
			9:00	48.5	53.9	58.7	57.6	54.9	56.4	50.4	48.2	64.1
			7:30	44.6	52.3	58.7	57.3	57.2	58.5	50.9	44.8	64.6
			6:00-Alternator	41.7	54.0	57.0	56.9	53.5	56.8	48.9	41.4	63.1
			4:30	42.4	52.9	59.1	57.5	56.2	60.4	52.2	46.9	65.2
8-pos. log avg.			46.7	53.3	58.8	57.8	56.1	58.3	51.4	47.3	64.6	

			Sound Pressure Levels, dB(A)									
Load	Distance, m (ft)	Enclosure	Measurement Clock Position	Octave Band Center Frequency (Hz)								Overall Level
				63	125	250	500	1000	2000	4000	8000	
No Load	7 (23)	Sound	3:00	40.2	52.1	56.9	55.0	52.8	52.8	47.1	42.1	61.6
			1:30	42.9	48.1	56.3	55.5	54.1	53.8	47.1	40.9	61.5
			12:00-Engine	46.1	50.2	59.5	59.4	54.9	54.3	47.4	40.7	64.1
			10:30	45.3	49.2	58.5	59.1	56.8	56.7	48.4	41.8	64.3
			9:00	41.6	52.4	57.8	57.8	53.2	52.4	46.2	42.0	62.7
			7:30	39.1	49.9	57.3	56.4	55.9	56.3	46.1	39.5	62.9
			6:00-Alternator	40.4	51.1	54.6	56.0	50.5	52.9	45.5	34.6	60.7
			4:30	38.6	49.4	58.1	55.4	54.0	57.3	47.7	40.8	62.9
8-pos. log avg.			42.6	50.5	57.6	57.1	54.4	54.9	47.0	40.7	62.7	

KOHLER®

Exhaust System Data

TECHNICAL INFORMATION BULLETIN

Enclosed Generator Set Exhaust System Data Sheet

Model	Enclosure Type	Consumed Back Pressure (in H2O)	Consumed Back Pressure (in Hg)	Back Pressure Limit(s) (in H2O)	Back Pressure Limit(s) (in Hg)	Flex Exhaust Tube(s)	Silencer	Drawing
50REOZK	All Weather & Sound Enclosures	20.1	1.5	24-36	1.7-2.6	GM94612	GM95578	ADV-8740
	All AQMD Weather & Sound Enclosures	23.2	1.7	32-54	2.3-4.0	GM102366 - Flex 483.002180.092.00.0 - Lombardini CAT	GM95578	ADV-8740

1. Total system exhaust back pressure is applicable to generator sets equipped with Kohler standard enclosure packages.
2. For generator sets with multiple exhaust outlets, total system exhaust back pressure value represents each outlet.
3. The total system back pressure should not exceed the manufacturer's recommended limit.
4. The total back pressure only includes exhaust components installed inside the Kohler enclosure. Customers must calculate any additional back pressure caused by piping, extensions, or components added after the silencer outlet. Refer to the installation manual for additional details.

KOHLER®

Emissions Data



UNITED STATES ENVIRONMENTAL PROTECTION AGENCY
2022 MODEL YEAR
CERTIFICATE OF CONFORMITY
WITH THE CLEAN AIR ACT

OFFICE OF TRANSPORTATION
AND AIR QUALITY
ANN ARBOR, MICHIGAN 48105

Certificate Issued To: Kohler Co.
(U.S. Manufacturer or Importer)
Certificate Number: NKHXL03.4EST-008

Effective Date:
09/02/2021
Expiration Date:
12/31/2022

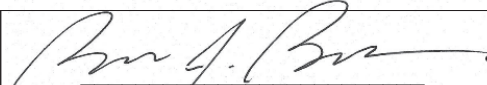
Byron J. Bunker, Division Director
Compliance Division

Issue Date:
09/02/2021
Revision Date:
N/A

Model Year: 2022
Manufacturer Type: Original Engine Manufacturer
Engine Family: NKHXL03.4EST

Mobile/Stationary Indicator: Stationary
Emissions Power Category: 56<=kW<75
Fuel Type: Diesel
After Treatment Devices: No After Treatment Devices Installed
Non-after Treatment Devices: Engine Design Modification

Pursuant to Section 111 and Section 213 of the Clean Air Act (42 U.S.C. sections 7411 and 7547) and 40 CFR Part 60, and subject to the terms and conditions prescribed in those provisions, this certificate of conformity is hereby issued with respect to the test engines which have been found to conform to applicable requirements and which represent the following engines, by engine family, more fully described in the documentation required by 40 CFR Part 60 and produced in the stated model year.

This certificate of conformity covers only those new compression-ignition engines which conform in all material respects to the design specifications that applied to those engines described in the documentation required by 40 CFR Part 60 and which are produced during the model year stated on this certificate of the said manufacturer, as defined in 40 CFR Part 60.

It is a term of this certificate that the manufacturer shall consent to all inspections described in 40 CFR 1068 and authorized in a warrant or court order. Failure to comply with the requirements of such a warrant or court order may lead to revocation or suspension of this certificate for reasons specified in 40 CFR Part 60. It is also a term of this certificate that this certificate may be revoked or suspended or rendered void *ab initio* for other reasons specified in 40 CFR Part 60.

This certificate does not cover engines sold, offered for sale, or introduced, or delivered for introduction, into commerce in the U.S. prior to the effective date of the certificate.

The actual engine power may lie outside the limits of the Emissions Power Category shown above. See the certificate application for details.

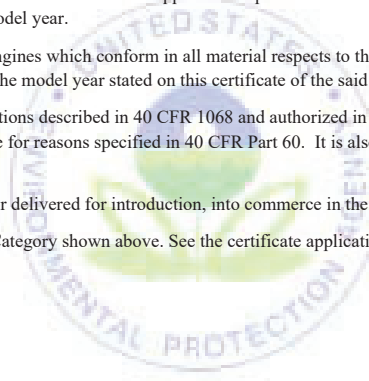

KOHLER®

Dimensional Drawings

MODEL	COB OPEN	GENSET WEIGHT (WET) KG (LBS)
40 4P/Q5X	52.6"	750 [1654]
40/50 4P/Q78X	53.6"	787 [1735]
50/60 4P/Q8X	54"	802 [1769]
60 4P/Q10X	55"	841 [1855]

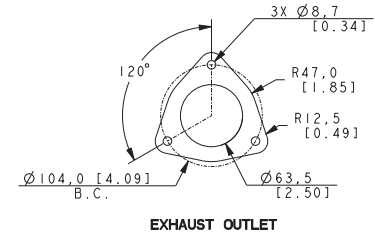
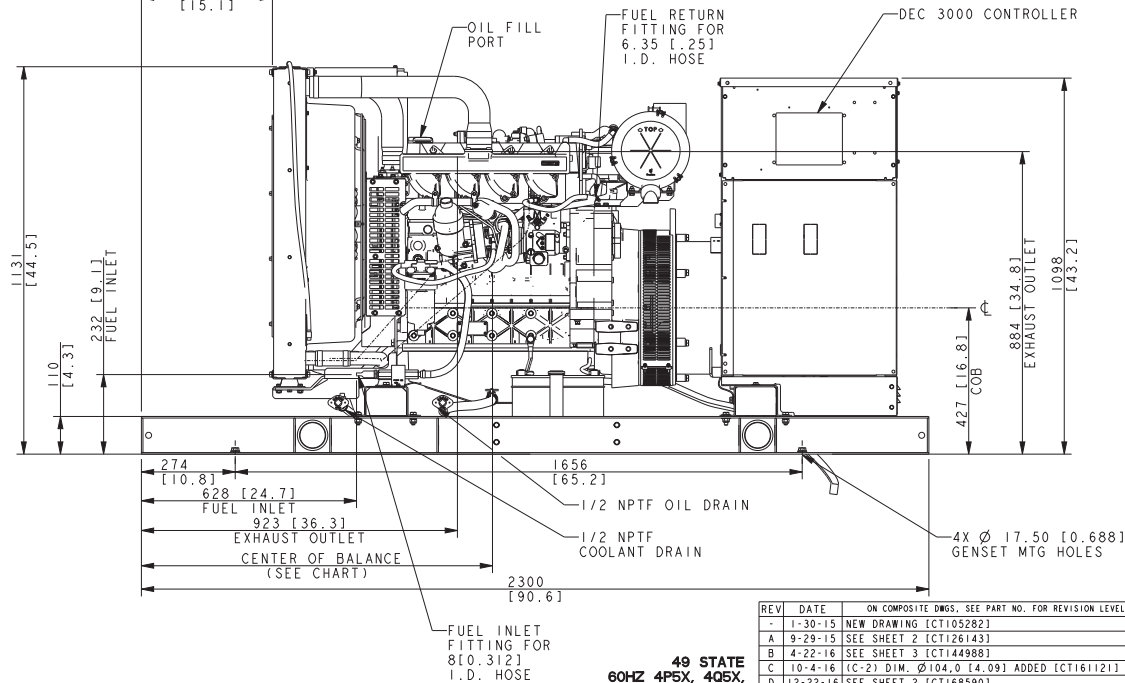
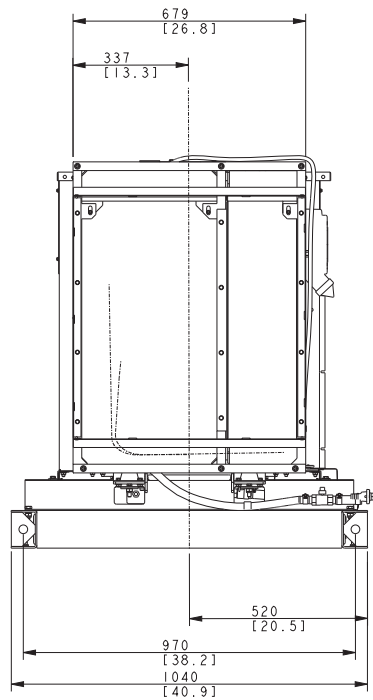

INSTALLATION NOTE:
IF A SUBBASE FUEL TANK AND/OR ENCLOSURE IS USED, REFER TO SUBBASE FUEL TANK ADV TO DETERMINE MOUNTING LOCATIONS.

- NOTES:
1. WHEN SUBBASE TANK IS USED, CONDUIT MUST BE LOCATED OUTSIDE OF TANK AREA OR IN STUB-UP AREA FOR SUBBASE TANK. REFER TO SUBBASE ADV.
 2. DIMENSIONS IN [] ARE ENGLISH EQUIVALENTS.
 3. IF AN ENCLOSURE IS USED, THE FUEL LINE MUST BE STUBBED UP FROM DIRECTLY UNDER THE UNIT OR BROUGHT IN FROM THE END OF THE SKID. REFER TO ENCLOSURE ADV.

49 STATE
60HZ 4P5X, 4Q5X,
4P7BX, 4Q7BX, 4P8X,
4Q8X, 4P10X, 4Q10X,
RECON. 600V ALTERNATORS
40,50,60KW KOHLER DIESEL

REV	DATE	ON COMPOSITE DWGS. SEE PART NO. FOR REVISION LEVEL	BY	UNLESS OTHERWISE SPECIFIED: 20 DIMENSIONS ARE IN MILLIMETERS TOLERANCES ARE:
-	1-30-15	NEW DRAWING [CT105282]	KNN	
A	9-29-15	SEE SHEET 2 [CT126143]	CEK	
B	4-22-16	SEE SHEET 3 [CT144988]	RRT	
C	10-4-16	(C-2) DIM. Ø104,0 [4.09] ADDED [CT161121]	ADP	
D	12-22-16	SEE SHEET 2 [CT168590]	ADP	
E	10-20-17	SHEETS 4, 5 & 6 ADDED [CT180516]	CEK	
F	2-2-18	SEE SHEETS 4 & 5 [CT184126]	CEK	
G	7-23-18	(B-3) CRANK CENTRE AXIS & DIM. 427 ADDED [CT188707]	ADP	

KOHLER CO. METRIC PRO-E
POWER SYSTEMS, KOHLER, WI 53044 U.S.A.
THIS DRAWING IN DESIGN AND DETAIL IS KOHLER CO. PROPERTY AND MUST NOT BE USED EXCEPT IN CONNECTION WITH KOHLER CO. WORK. ALL RIGHTS OF DESIGN OR INVENTION ARE RESERVED.

TITLE: DIMENSION PRINT 40-60 KW KDI

SCALE: 0.1:1 CAD NO. SHEET: 1 of 6
DWG NO. **ADV-8739**

APPROVALS: DATE
DRAWN: KNN 1-30-15
CHECKED: KNN 1-30-15
APPROVED: DMK 1-30-15

MODEL	DESCRIPTION	ENCLOSURE WEIGHT KG [LBS]	ENCLOSED CENTER OF BALANCE
4P5X	STEEL WEATHER, 40-60KW	261 [575]	50.3
	STEEL SOUND, 40-60KW	272 [600]	50.3
	ALUMINUM SOUND, 40-60KW	170 [375]	51.0
4P7BX	STEEL WEATHER, 40-60KW	261 [575]	51.1
	STEEL SOUND, 40-60KW	272 [600]	51.1
4P8X	ALUMINUM SOUND, 40-60KW	170 [375]	51.8
	STEEL WEATHER, 40-60KW	261 [575]	51.5
	STEEL SOUND, 40-60KW	272 [600]	51.4
4P10X	ALUMINUM SOUND, 40-60KW	170 [375]	52.2
	STEEL WEATHER, 40-60KW	261 [575]	52.2
	STEEL SOUND, 40-60KW	272 [600]	52.1
	ALUMINUM SOUND, 40-60KW	170 [375]	52.9

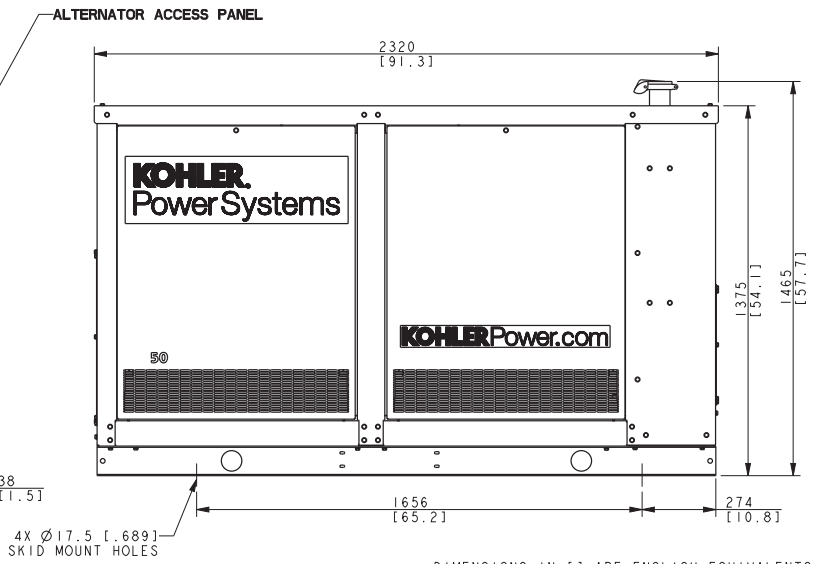
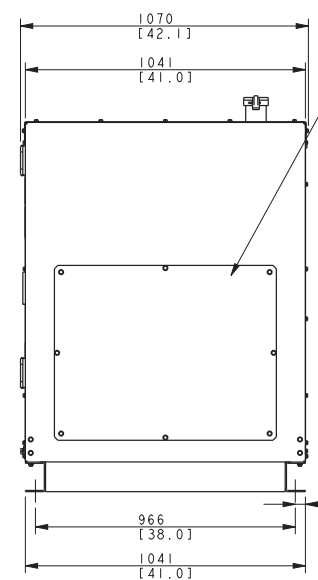
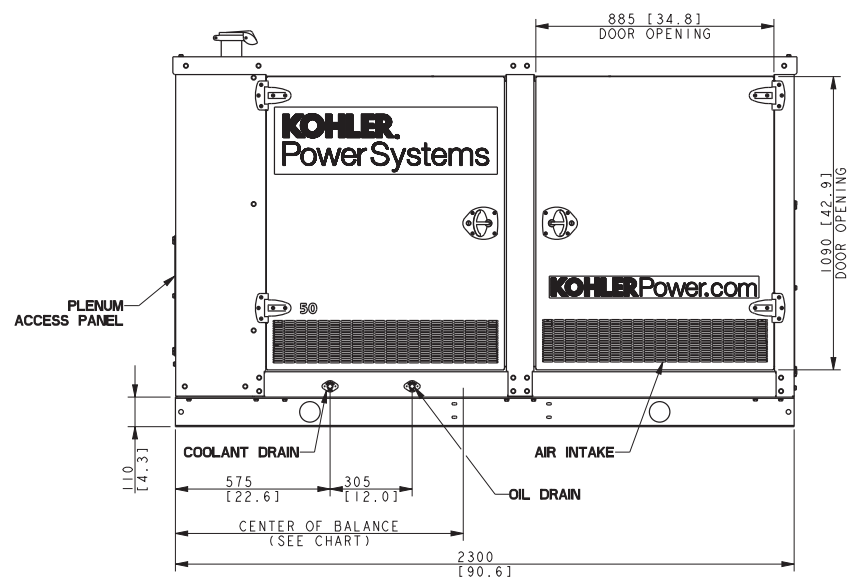
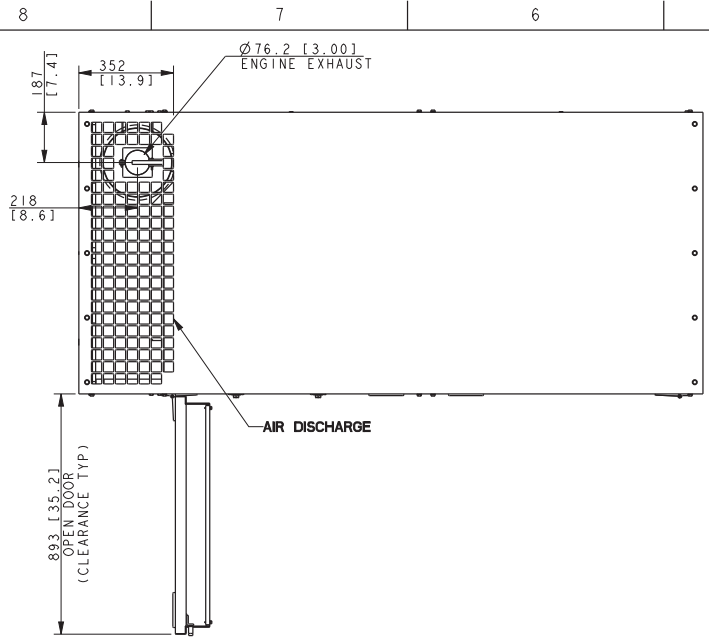

NOTE:
 1. IF TANK IS ORDERED, ENCLOSURE MOUNT DIRECTLY TO TANK.
 2. TANK MAY EXTEND BEYOND ENCLOSURE (DISCHARGE END ONLY)

60HZ 4P5X, 4Q5X,
 4P7BX, 4Q7BX, 4P8X,
 4Q8X, 4P10X, 4Q10X,
 RECON. 600V ALTERNATORS
 40,50,60 KW KOHLER DIESEL

REV	DATE	ON COMPOSITE DWGS. SEE PART NO. FOR REVISION LEVEL	BY	UNLESS OTHERWISE SPECIFIED: 1) DIMENSIONS ARE IN MILLIMETERS 2) TOLERANCES ARE:
-	2-03-15	NEW DRAWING (CT105282)	KNN	±.1X
A	9-25-17	(D-7) DIM. $\phi 76.2$ [3.00] ADDED [CT177004]	SRM	±.1X

APPROVALS	DATE	TITLE
DRW: KNN	02.03.15	DIMENSION PRINT, ENCL. 40-60 KW KDI
CHEK: KNN	02.03.15	
APPROV: BMK	02.03.15	

SCALE	0.11	CAD NO.		SHEET	1	of	1
ADV-8740							D

DIMENSIONS IN [] ARE ENGLISH EQUIVALENTS

KOHLER CO. METRIC PRO-E
 POWER SYSTEMS, KOHLER, WI 53044 U.S.A.
 THIS DRAWING IN DESIGN AND DETAIL IS KOHLER CO. PROPERTY AND MUST NOT BE USED EXCEPT IN CONNECTION WITH KOHLER CO. WORK. ALL RIGHTS OF DESIGN OR INVENTION ARE RESERVED.

PART NO.	REV	ITEM 1	ITEM 2	ITEM 3	COMMENTS
GM85123-1	C	GM85127	GM85129	GM86126-1	MULTIPLE ATS
GM85123-2	C	GM85131	GM85129	GM86126-2	SINGLE ATS
GM85123-3	C	GM85132	-	GM86126-3	ANNUNCIATOR ONLY
GM85123-4	C	GM85133	-	GM86126-3	SDMO - ANNUNCIATOR ONLY

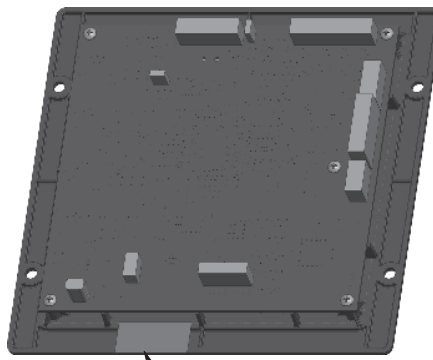
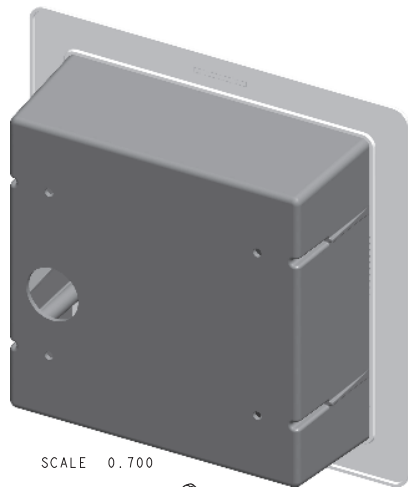

- NOTES:
- FUNCTIONALLY TEST ACCORDING TO ISO DOCUMENT ETF-WI-001, PER SPECIFICATION ETF-TD-003.
 - ASSEMBLE PCBA TO BACK OF BEZEL USING FIXTURE JT-0001.
 - TORQUE ALL SCREWS TO 7-10 in lbs.
 - PEEL BACKING OFF FACE PLATE AND APPLY TO BEZEL. APPLY EVEN PRESSURE TO ENTIRE SURFACE TO ENSURE COMPLETE ADHESION.

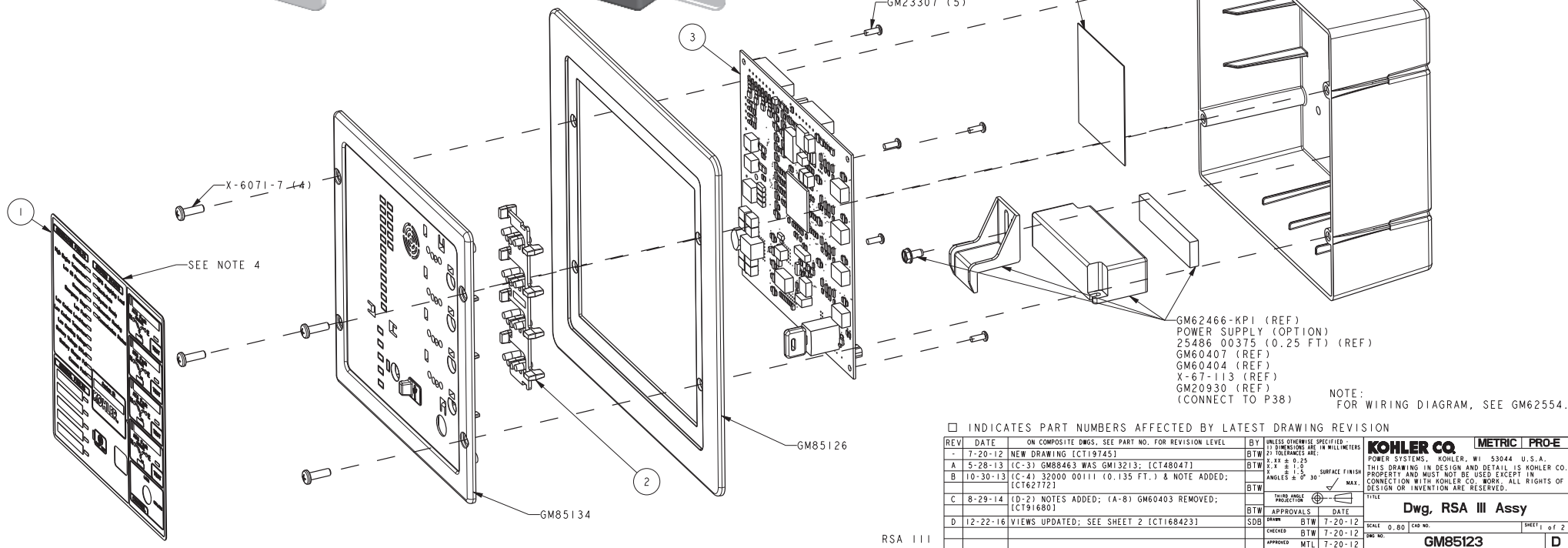

REV	DATE	ON COMPOSITE DWGS. SEE PART NO. FOR REVISION LEVEL	BY	UNLESS OTHERWISE SPECIFIED: 2) DIMENSIONS ARE IN MILLIMETERS	KOHLER CO. METRIC PRO-E POWER SYSTEMS, KOHLER, WI 53044 U.S.A. THIS DRAWING IN DESIGN AND DETAIL IS KOHLER CO. PROPERTY AND MUST NOT BE USED EXCEPT IN CONNECTION WITH KOHLER CO. WORK. ALL RIGHTS OF DESIGN OR INVENTION ARE RESERVED.
-	7-20-12	NEW DRAWING [CT19745]	BTW	2) TOLERANCES ARE: X .XX ± 0.25 Y .X ± 0.15 ANGLES ± 0° 30' / MAX.	
A	5-28-13	(C-3) GM88463 WAS GM13213; [CT48047]	BTW		TITLE Dwg, RSA III Assy SCALE 0.80 CAD NO. GM85123 SHEET 1 of 2
B	10-30-13	(C-4) 32000 00111 (0.135 FT.) & NOTE ADDED; [CT62772]	BTW		
C	8-29-14	(D-2) NOTES ADDED; (A-8) GM60403 REMOVED; [CT91680]	BTW		
D	12-22-16	VIEWS UPDATED; SEE SHEET 2 [CT1684231]	BTW		
			BTW	APPROVALS DATE	
			SDH	BTW	7-20-12
			BTW	BTW	7-20-12
			APPROVED	MTL	7-20-12

RSA III

8 7 6 5 4 3 2 1

SNAP ITEM 2 INTO THIS LOCATION BEING SURE TO LINE-UP ALL LIGHT PIPES TO MATCHING SOCKETS ON BEZEL.

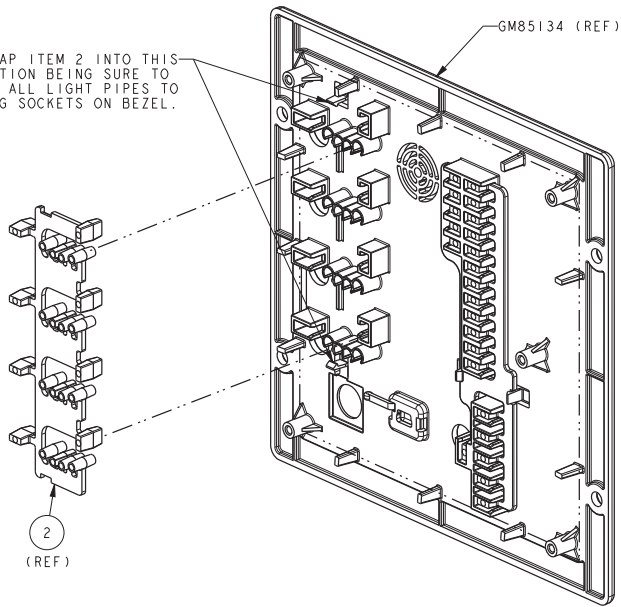

BACK VIEW OF BEZEL
SCALE 1.000

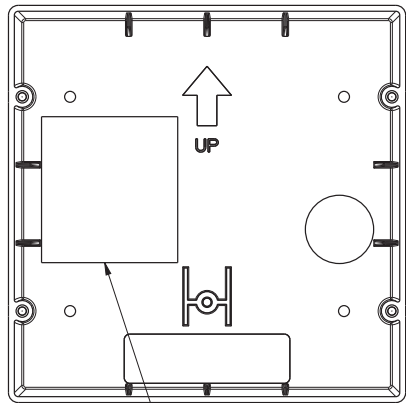

GM88463 (REF) GM85125 (REF)

VIEW B
FRONT OF BOX

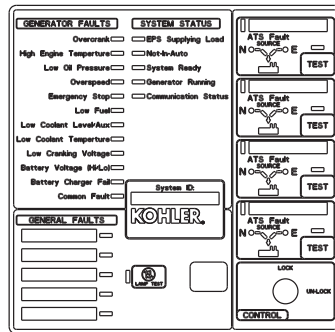

ITEM 1
(P/N: GM85127 REF)

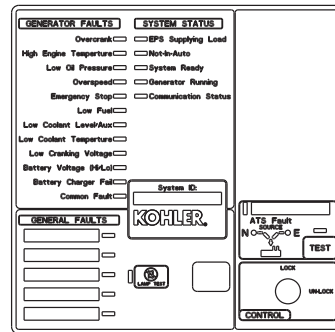

ITEM 1
(P/N: GM85131 REF)

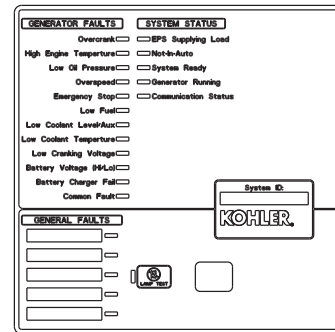

ITEM 1
(P/N: GM85132 REF)

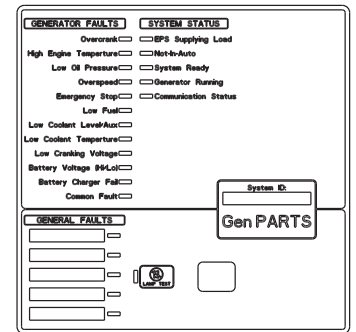

ITEM 1
(P/N: GM85133 REF)

REV	DATE	ON COMPOSITE DWGS. SEE PART NO. FOR REVISION LEVEL	BY	UNLESS OTHERWISE SPECIFIED: 2) DIMENSIONS ARE IN MILLIMETERS	TOLERANCES ARE:	KOHLER CO. METRIC PRO-E POWER SYSTEMS, KOHLER, WI 53044 U.S.A. THIS DRAWING IN DESIGN AND DETAIL IS KOHLER CO. PROPERTY AND MUST NOT BE USED EXCEPT IN CONNECTION WITH KOHLER CO. WORK. ALL RIGHTS OF DESIGN OR INVENTION ARE RESERVED.
-	7-30-12	NEW DRAWING [CT19745]	BTW	X .XX ± 0.25	Z .P ± 1.5 SURFACE FINISH	
A	5-28-13	(A-8) GM88463 (REF) WAS GM13213 (REF); [CT48047]	BTW	ANGLES ± 0° 30' / MAX.		
B	10-30-13	SEE SHEET 1 [CT62772]	BTW			
C	8-29-14	VIEW A REMOVED; [CT91680]	BTW			
D	12-22-16	VIEWS UPDATED; SEE SHEET 1 [CT168423]	SDR	APPROVALS	DATE	
			DRW	BTW	7-30-12	
			CHECKED	BTW	7-30-12	
			APPROVED	MTL	7-30-12	

MODEL	CAPACITY		WEIGHT		LENGTH		HEIGHT		STUB-UP LENGTH		LIFTING EYE DIM A		MTG HOLES	EMERGENCY VENT (A) INNER/OUTER	
	LITERS	GAL	KG	LBS	MM	IN	MM	IN	MM	IN	MM	IN	QTY	IN	
40/50/60kW	541	142	466	1027	2895.6	114.0	431.8	17.0	408.0	16.1	2184.5	86.0	6	3/3	
50/60kW	898	237	599	1321	2895.6	114.0	660.4	26.0	408.0	16.1	2184.5	86.0	6	3/3	
40/60kW	1057	279	658	1452	2895.6	114.0	762.0	30.0	408.0	16.1	2184.3	86.0	6	3/4	
40/50/60kW	1520	401	777	1714	2895.6	114.0	914.4	36.0	304.8	12.0	2184.3	86.0	6	4/4	
50/60kW	2028	535	978	2156	4019.6	158.3	914.4	36.0	408.0	16.1	2467.9	97.2	8	4/5	

TANK FITTINGS:

- A. A" NPT EMERGENCY VENT FITTING PER NFPA 30 WITH VENT CAPS (QTY 2).
- B. 4" NPT FUEL FILL FITTING BUSHED TO 2" NPT WITH LOCKABLE FILL CAP AND 2" RISER
- C. 2" NPT FUEL LEVEL GAUGE FITTING W/ DIRECT READING MECHANICAL GAUGE.
- D. 2" NPT NORMAL VENT FITTING WITH MUSHROOM VENT CAP AND 5" RISER.
- E. 1/2" NPT FITTING FOR REMOVABLE ENGINE SUPPLY DIP TUBE (3/8" NPT FEMALE) WITH CHECK VALVE.
- F. 1/2" NPT FITTING FOR REMOVABLE FUEL RETURN DIP TUBE (3/8" NPT FEMALE).
- H. 2" NPT FUEL LEVEL SENDING UNIT.
- J. 2" NPT FITTING FOR OPTIONAL SWITCH (INSTALL 2"NPT PIPE PLUG)
- N. 2" NPT FOR FUEL IN BASIN SWITCH
- P. 2" NPT FITTING FOR OPTIONAL SWITCH (INSTALL 2"NPT PIPE PLUG)

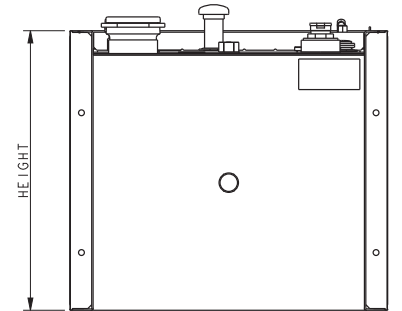
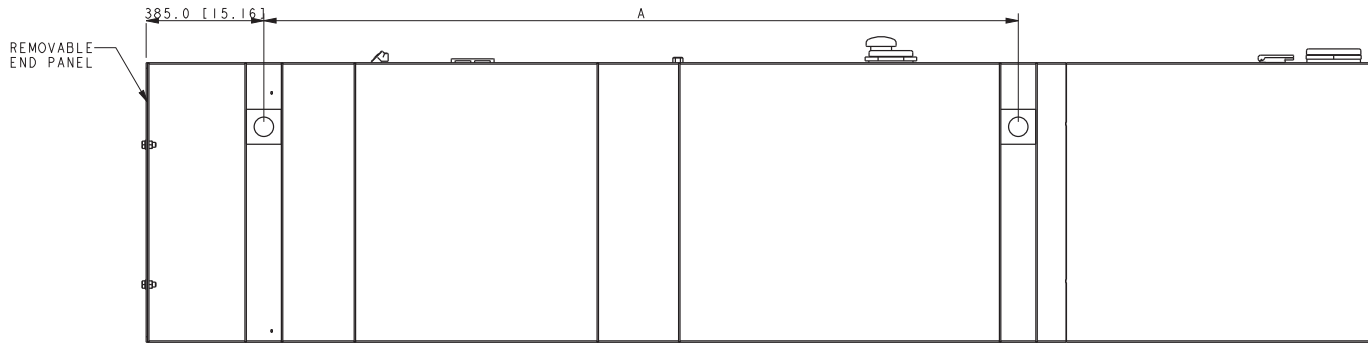
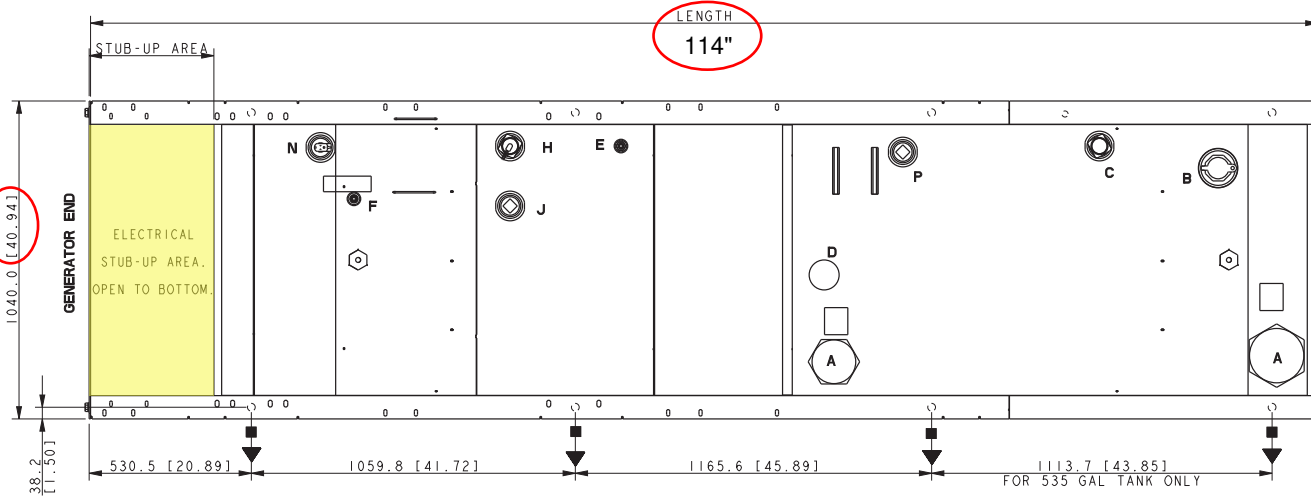

NOTE:
FOR FURTHER TANK DETAIL
SEE INDIVIDUAL DRAWINGS

- Ø25.4 [1.00] STANDARD MOUNTING
- ▼ Ø25.4 [1.00] BOTTOM BEAM MOUNTING

STATE TANK

REV	DATE	ON COMPOSITE DWGS. SEE PART NO. FOR REVISION LEVEL	BY	UNLESS OTHERWISE SPECIFIED: 20 DIMENSIONS ARE IN MILLIMETERS	KOHLER CO. METRIC PRO-E <small>POWER SYSTEMS, KOHLER, WI 53044 U.S.A.</small> <small>THIS DRAWING IN DESIGN AND DETAIL IS KOHLER CO. PROPERTY AND MUST NOT BE USED EXCEPT IN CONNECTION WITH KOHLER CO. WORK. ALL RIGHTS OF DESIGN OR INVENTION ARE RESERVED.</small>
-	11-18-14	NEW DRAWING [CT99811]	SDS	21 TOLERANCES ARE: X .XX ± 0.25 Z .X ± 1.5 SURFACE FINISH ANGLES ± 0° 30' / MAX.	
A	2-3-15	(D-5) DIM A AND MTG HOLES QTY ADDED (B-4) 1113.7 DIM ADDED [CT105100]	SAM		TITLE DIMENSION PRINT <small>SCALE 0.13 CAD NO.</small> <small>SHEET 2 of 2</small> ADV-8753
B	1-18-18	(D-8) 40/50/60kW, 50/60kW WAS 40/60kW; (D-5) 2184.3 WAS 2184.5, 2467.9 WAS 2498.4; SEE SHEET 1 [CT183307]	SRM		
			APPROVALS	DATE	
			SDS	11-18-14	
			CHECKED	SDS	11-18-14
			APPROVED	AJD	11-18-14

KOHLER®

Miscellaneous

OVERVIEW:
 THE AUTOMATIC MULTI-LEVEL FLOAT/ EQUALIZE CHARGER SPECIFIED BELOW IS INTENDED TO CHARGE ENGINE STARTING BATTERIES EITHER INDEPENDENT OR IN CONJUNCTION WITH AN ENGINE DRIVEN CHARGING SYSTEM.

BATTERY TYPES TO BE CHARGED:

- LEAD ACID
- AGM
- GEL CELL
- HIGH PERFORMANCE AGM
- FLOODED
- NICKEL CADMIUM (NiCd)

INPUT AC:

INPUT VOLTAGE: 90-265V SINGLE PHASE
 INPUT FREQUENCY: 47-63 Hz

INPUT LEAD:

APPROXIMATELY 1.8M (72") (REF) TYPE SJTOW -40°C TO 105°C UL RATED WIRE AND INSULATION. TERMINATED IN PRE-MOLDED UL RATED 3 PRONG NEMA 5-15 MALE AC PLUG.

DC OUTPUT:

10A @ 12V
 10A @ 24V
 VOLTAGE REGULATION: +/-1% (VOLTAGE AT EACH STAGE IS TOPOLOGY DEPENDENT)

OUTPUT LEAD:

APPROX. 1.8M (72") (REF) TYPE SJT00W -40°C TO 105°C UL RATED WIRE WITH RED AND BLACK WIRE INSULATION. TERMINATED IN 9.5 mm (REF) RING STYLE TERMINALS.

FUSES:

THE FUSE MUST BE LOCATED APPROXIMATELY 6" FROM RING TERMINAL ON RED OUTPUT LEAD.
 20A ATC

ENVIRONMENTAL:

STORAGE TEMPERATURE RANGE: -40 TO +85°C (-40 TO +185°F)
 OPERATING TEMPERATURE RANGE: -20 TO +70°C (-4 TO +158°F)
 HUMIDITY: 5 TO 95% (NON-CONDENSING)
 SALT SPRAY TESTING - ASTM B117
 CORROSION RESISTANT FROM GASSING OF BATTERIES

REVERSE POLARITY PROTECTION:

THE CHARGER SHALL SUSTAIN NO DAMAGE WHEN INCORRECTLY CONNECTED TO THE BATTERY IN REVERSE ORIENTATION.

MOUNTING:

4 NON-THREADED THROUGH HOLES FOR M6 FASTENERS TO PASS THROUGH

ENCLOSURE:

SHALL PROTECT THE CHARGER COMPONENTS FROM RAIN, SNOW, DUST AND DRIPPING WATER AND UNINTENTIONAL IMPACTS. ALL INTERNAL COMPONENTS PROTECTED FROM WATER DROPLETS.

INDICATORS:

POWER: INDICATES THE ACCEPTABILITY OF AC INPUT TO THE CHARGER
 COMMUNICATION: INDICATES THE STATE OF THE COMMUNICATION SYSTEM
 TEMPERATURE COMPENSATION: INDICATES THE STATE OF THE TEMPERATURE COMPENSATION SUBSYSTEM WHEN INSTALLED
 VOLTAGE OUTPUT: INDICATES THE STATE OF THE BATTERY AND CERTAIN FAULT CONDITIONS.

DOCUMENTATION:

THERE SHALL BE AN INSTALLATION / OPERATIONAL MANUAL SUPPLIED WITH EACH CHARGER. PER KOHLER SUPPLIED ARTWORK.

CERTIFICATIONS (US AND CANADA):

- UL1236
- CSA - C22.2 NO 107.2-01
- FCC- TITLE 47, PART 15 CLASS A
- CE
- EN 61000-6-2
- CEC AND DOE
- NFPA-110 LEVEL 1 (WHEN SUPPORTED WITH APPLICABLE KOHLER CONTROLLER)
- IBC

PRODUCT LABELING:

THE LABEL ATTACHED TO THE CHARGER SHALL HAVE THE FOLLOWING INFORMATION:

- UL LISTING
- KOHLER PART NUMBER
- DESCRIPTION OF ALL INDICATOR
- OUTPUT CURRENT AND VOLTAGE
- INPUT VOLTAGE AND FREQUENCY

PACKAGING LABEL:
 THE PACKAGING LABEL SHALL CONTAIN THE FOLLOWING INFORMATION:
 KOHLER P/N
 DESCRIPTION - BATTERY CHARGER
 MFG. MODEL NO
 MFG. PART NUMBER
 DATE CODE

WARRANTY:
 2 YEAR FROM DATE OF PURCHASE FROM MANUFACTURE.

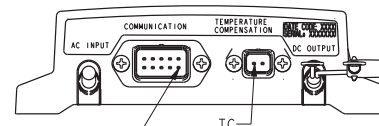
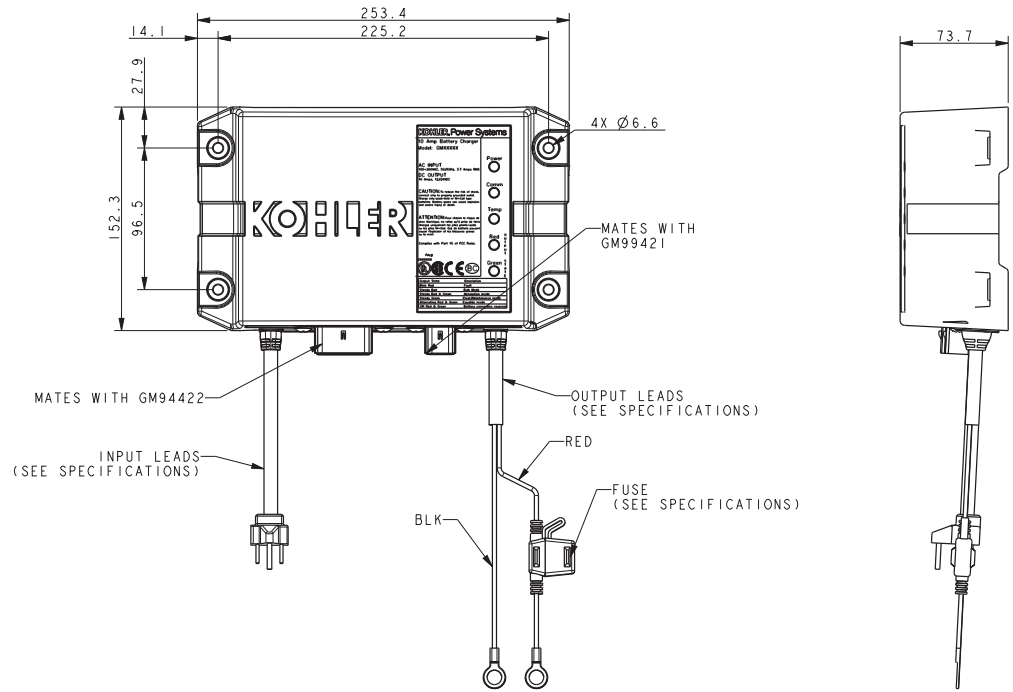

- COM
 PIN 1 N/C
 2 ID SEL 1
 3 ID SEL 2
 4 N/C
 5 CAN-H
 6 N/C
 7 ID SEL 1 RTN
 8 ID SEL 2 RTN
 9 CAN-GND
 10 CAN-L
- IC
 PIN 1 TC SENSOR W1
 2 TC SENSOR W2

REV	DATE	ON COMPOSITE DWGS. SEE PART NO. FOR REVISION LEVEL	BY	UNLESS OTHERWISE SPECIFIED: 1) DIMENSIONS ARE IN MILLIMETERS 2) TOLERANCES ARE: X .XX ± 0.25 Z .X ± 1.5 SURFACE FINISH ANGLES ± 0° 30' MAX.								
-	9-22-14	NEW DRAWING [CT91634]	SAM									
A	5-9-17	(C-4, 2) MATING NOTE ADDED (A-2, 4) PIN CONNECTIONS ADDED [CT174256]	SAM									
<table border="1"> <thead> <tr> <th>APPROVALS</th> <th>DATE</th> </tr> </thead> <tbody> <tr> <td>DRWN: SAM</td> <td>9-22-14</td> </tr> <tr> <td>CHECKED: SAM</td> <td>9-22-14</td> </tr> <tr> <td>APPROVED: AGT</td> <td>9-22-14</td> </tr> </tbody> </table>					APPROVALS	DATE	DRWN: SAM	9-22-14	CHECKED: SAM	9-22-14	APPROVED: AGT	9-22-14
APPROVALS	DATE											
DRWN: SAM	9-22-14											
CHECKED: SAM	9-22-14											
APPROVED: AGT	9-22-14											
KOHLER CO. METRIC PRO-E POWER SYSTEMS, KOHLER, WI 53044 U.S.A. THIS DRAWING IN DESIGN AND DETAIL IS KOHLER CO. PROPERTY AND MUST NOT BE USED EXCEPT IN CONNECTION WITH KOHLER CO. WORK. ALL RIGHTS OF DESIGN OR INVENTION ARE RESERVED.				TITLE: CHARGER, BATTERY 10 AMP SCALE: 0.50 CAD NO. SHEET 1 of 1 DWG NO. GM87448								

KIT NUMBER	VIEW	DESCRIPTION
GM94447-KA1	VIEW 1&3	BATTERY CHARGER, FLOAT 12V/24V 10A
GM94447-KA2	VIEW 2	BATTERY CHARGER, FLOAT 24V 10A

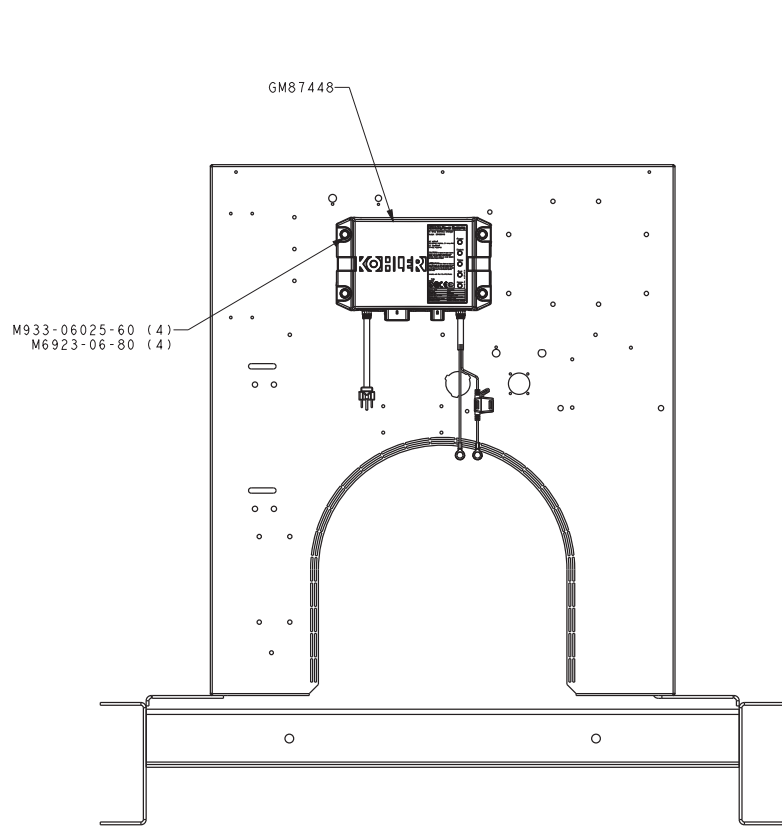

VIEW 1

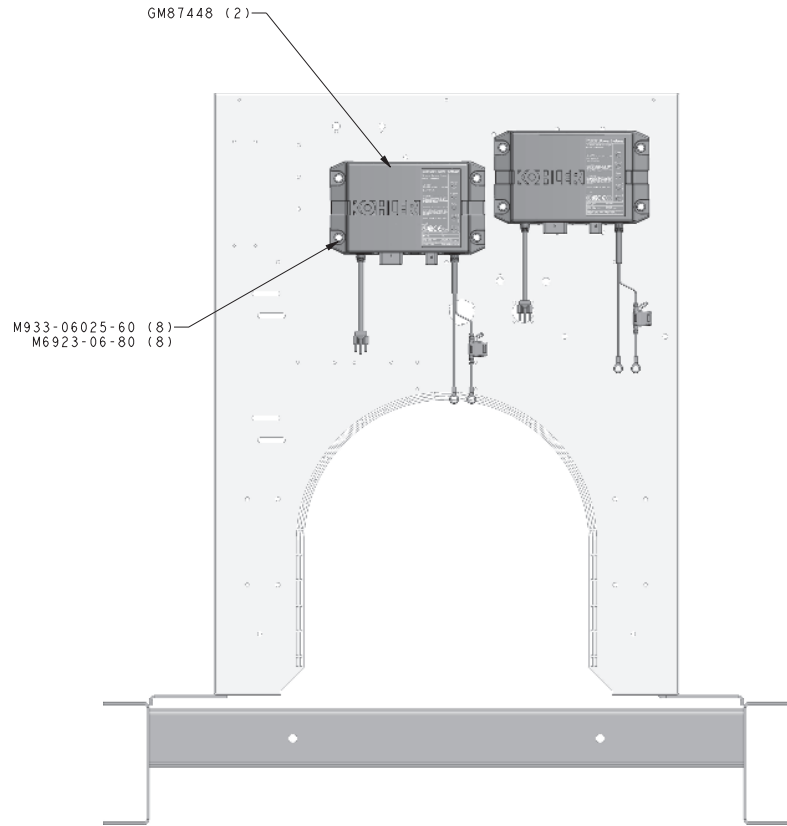

VIEW 2

NOTE:
FOR PROPER ASSEMBLY METHOD OF HARDWARE, USE G-585 AS A GUIDELINE.
THIS ASSEMBLY OR PART MUST COMPLY WITH PEP-RML-001

REV	DATE	ON COMPOSITE DWGS. SEE PART NO. FOR REVISION LEVEL	BY	UNLESS OTHERWISE SPECIFIED: 2) DIMENSIONS ARE IN MILLIMETERS	KOHLER CO. METRIC PRO-E
-	9-23-14	NEW DRAWING [CT94502]	SAM	2) TOLERANCES ARE: KRM 2. XX ± 0.25	POWER SYSTEMS, KOHLER, WI 53044 U.S.A. THIS DRAWING IN DESIGN AND DETAIL IS KOHLER CO. PROPERTY AND MUST NOT BE USED EXCEPT IN CONNECTION WITH KOHLER CO. WORK. ALL RIGHTS OF DESIGN OR INVENTION ARE RESERVED.
A	2-16-18	SHEET 2 ADDED; SEE SHEET 2 [CT184382]		2. P ± 1.5 SURFACE FINISH ANGLES ± 0° 30' MAX.	
B	04MAY2022	(D-7) GM94447-KA1 DESCRIPTION UPDATED, (A-3) *PEP-RML-001* NOTE ADDED [CT219524]	PBC		
				TYPICAL PROJECTION	TITLE
				APPROVALS	DWG, ASSY BATTERY CHARGER
				DATE	SCALE 0.40 CAD NO.
				9-23-14	SHEET 1 of 2
				CHECKED SAM	DWG NO. GM94447
				9-23-14	D
				APPROVED AGT	
				9-23-14	

REVISIONS						
REV.	ECO	DATE	DESCRIPTION	AUTH.	DR.	ZONE
2	9257	10-11-17	CHANGED CORD LENGTHS	YP	BLF	C3, D3
3	9459	08-29-18	UPDATED ELEMENT BEND PROFILE	YP	BLF	B2, B6, B7
4	9459	10-02-18	CHANGED SENSING UNIT TO 60-80F	YP	BLF	A5, A6, C2

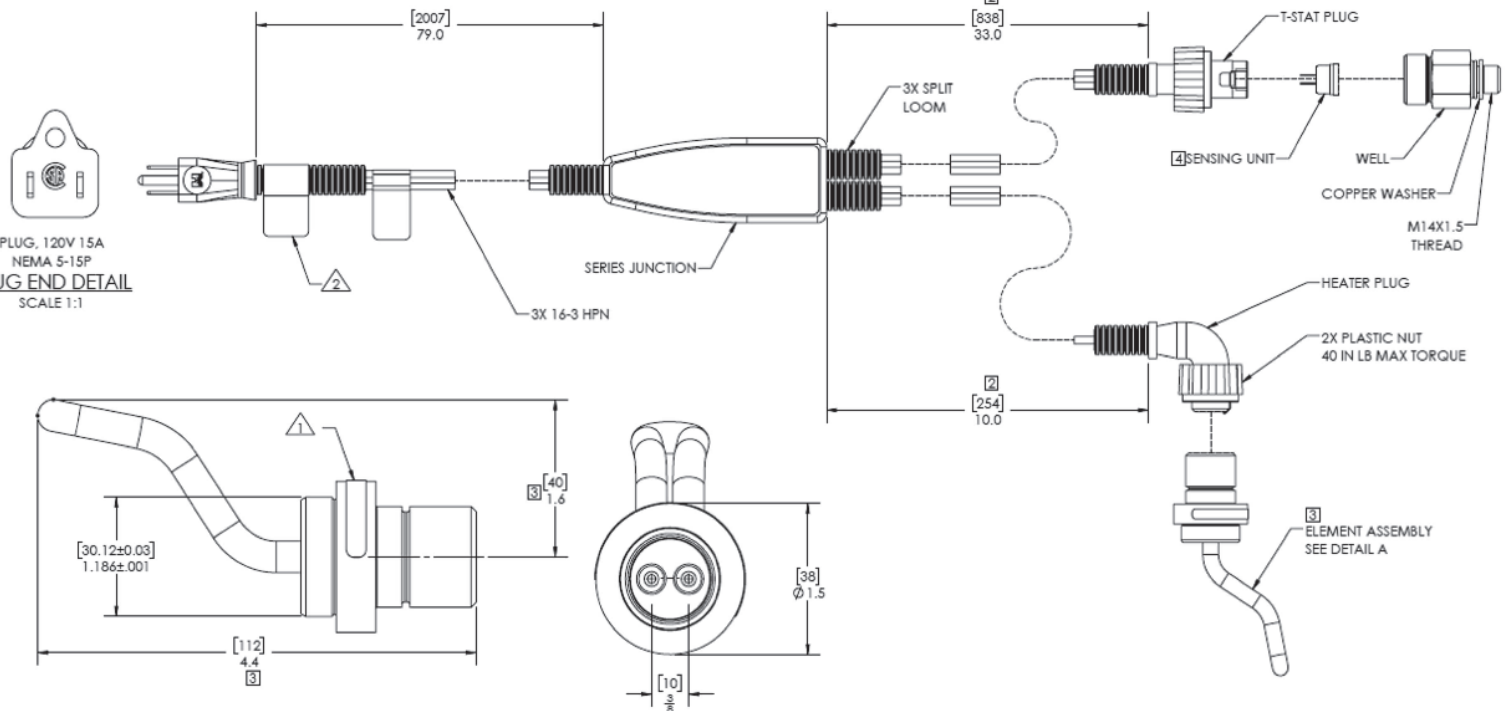

PLUG, 120V 15A
NEMA 5-15P
PLUG END DETAIL
SCALE 1:1

ELEMENT ASSEMBLY DETAIL A
SCALE 1:1

- NOTES:**
- ① LABELED WITH PART NUMBER, WATTS, VOLTS AND DATE CODE.
 - ② LABELED WITH PART NUMBER, TEMPERATURE RANGE AND DATE CODE.
 - 3. DIMENSIONS ARE FOR REFERENCE ONLY.

PART NUMBER	DESCRIPTION	SENSING UNIT	CUSTOMER
GM103076	IB FP ELEM ASM 1000W 120V 30mm TO W/WELL M14STCW 60-80F	60-80°F [16-27°C]	KOHLER

HOTSTART, INC. SPOKANE, WA.
PROPRIETARY INFORMATION

This drawing and the information shown on it are property of Hotstart, Inc. and are for the sole purpose of doing business with us. Any reproduction or use of this drawing or the information shown on it by any other party is strictly prohibited without our prior written consent.

TITLE
IB FP ELEM ASM 1000W 120V 30mm TO W/WELL M14STCW 60-80F

DESIGN NO.
A-8478-05

APPROVALS:

DRAWN BY	DATE	UNLESS OTHERWISE SPECIFIED DIMENSIONS ARE IN INCHES (PREF)	DESIGN NO.
BLF	06-05-17	TOLERANCES	A-8478-05
APPROVED BY	DATE	FRACTIONAL	ORIGIN
YP	06-06-17	XX ± N/A	CO9257
		XXX ± N/A	SCALE: 1:2
		DO NOT SCALE DRAWING	SPEED: 1 OF 1
			REV: 4

- ⊗ DENOTES A CRITICAL CHARACTERISTIC THAT MUST BE ADDRESSED IN THE PRODUCTION CONTROL PLAN. TOTAL QUANTITY OF CRITICAL CHARACTERISTICS ON THIS DRAWING = 0
 - ⊕ DENOTES A MAJOR CHARACTERISTIC THAT MUST BE ADDRESSED IN THE PRODUCTION CONTROL PLAN. TOTAL QUANTITY OF MAJOR CHARACTERISTICS ON THIS DRAWING = 0
- DIMENSIONS ARE REFERENCE ONLY.
- PART MAY NOT BE AS PICTURED.

LOMBARDINI 40-80KW

REV	DATE	ON COMPOSITE DWGS. SEE PART NO. FOR REVISION LEVEL	BY	DO NOT SCALE. REFERENCE THE MODEL FOR ALL UNSPECIFIED DIMENSIONS
-	6-19-17	NEW DRAWING [173822]	CEK	UNLESS OTHERWISE SPECIFIED: ALL DIMENSIONS IN MILLIMETERS
A	10-10-18	(A-6) 60-80°F [16-27°C] WAS 80-100F (27-38C) [CT190210]	SLR	GENERAL TOLERANCES: F ±.13 ±.05 M ±.13 ±.05 H ±.13 ±.05 ANGLES & P.30
				SURFACE FINISH ✓ MAX.
				APPROVALS: DATE
				SCALE: N/A CAD NO. SHEET 1 OF 1
				DWG NO. GM103076

KOHLER
KOHLER, WISCONSIN 53044

THIS DRAWING IN DESIGN AND DETAIL IS KOHLER CO. PROPERTY AND MUST NOT BE USED EXCEPT IN CONNECTION WITH KOHLER CO. WORK. ALL RIGHTS OF DESIGN OR INVENTION ARE RESERVED.

TITLE
BLOCK HEATER, 120V, 1000W

SCALE: N/A CAD NO. SHEET 1 OF 1

DWG NO. GM103076

KIT NO.	ITEM	PART NO	QTY	DESCRIPTION
GM103743				E-STOP, NEC REMOTE
	1	GM103743-1	1	E-STOP W/ YELLOW SHROUD, LOTO
	2	GM103743-2	4	#10 X 1.25 Sheetmetal Screw
	3	GM103743-3	1	TERMINAL, FAST-ON, MALE, 18-22 AWG
	4	GM103743-4	1	TERMINAL, FAST-ON, FEMALE, 18-22 AWG
	5	GM103743-5	2	TERMINAL, SPADE, 22-16 AWG
	6	GM103743-6	1	LITERATURE, TT-1736

THIS IS AN AUTOMATED TABLE. ALL UPDATES MUST BE MADE IN THE ASSEMBLY.

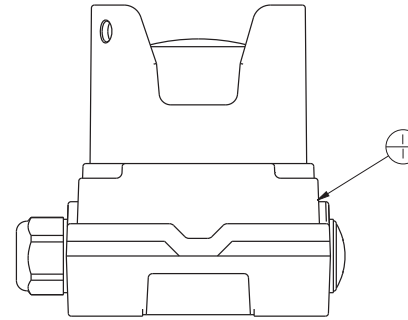
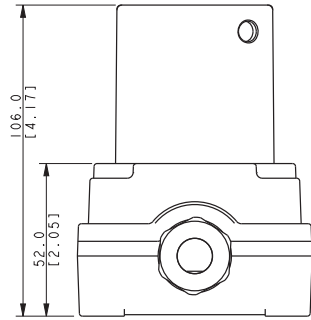
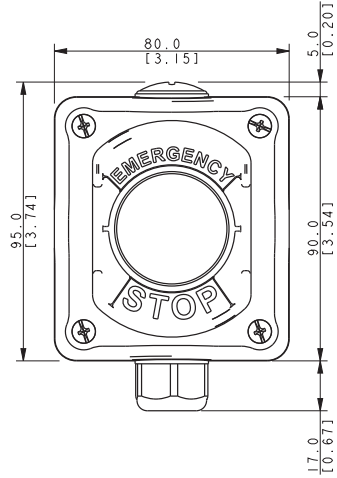

SCALE 1.50

NOTE:

DIMENSIONS IN [] ARE IN INCH EQUIVALENTS.

SCREWS AND TERMINALS ARE TO BE BAGGED AND PLACED IN THE BOX

REV	DATE	ON COMPOSITE DWGS. SEE PART NO. FOR REVISION LEVEL	BY	UNLESS OTHERWISE SPECIFIED: 1) DIMENSIONS ARE IN MILLIMETERS 2) TOLERANCES ARE: X.XX ± 0.25 X.X ± 0.5 X ± 1.5 SURFACE FINISH ANGLES ± 0° 30' / MAX.	TITLED PROJECTION								
-	2-12-18	NEW DRAWING (CT176728)	CCL		<table border="1"> <tr> <td>APPROVALS</td> <td>DATE</td> </tr> <tr> <td>DRWN</td> <td>CCL 2-12-18</td> </tr> <tr> <td>CHECKED</td> <td>NJB 2-12-18</td> </tr> <tr> <td>APPROVED</td> <td>KJB 2-12-18</td> </tr> </table>	APPROVALS	DATE	DRWN	CCL 2-12-18	CHECKED	NJB 2-12-18	APPROVED	KJB 2-12-18
APPROVALS	DATE												
DRWN	CCL 2-12-18												
CHECKED	NJB 2-12-18												
APPROVED	KJB 2-12-18												

KOHLER CO. | METRIC | PRO-E
POWER SYSTEMS, KOHLER, WI 53044 U.S.A.
THIS DRAWING IN DESIGN AND DETAIL IS KOHLER CO. PROPERTY AND MUST NOT BE USED EXCEPT IN CONNECTION WITH KOHLER CO. WORK. ALL RIGHTS OF DESIGN OR INVENTION ARE RESERVED.

TITLE: **E-STOP, NEC REMOTE**
SCALE: 1.50 | CAD NO.:
Dwg No: **GM103743** | SHEET 1 of 1

KOHLER®

Warranty

Stationary Standby and Prime Power Industrial Generator Set One-Year or Two Thousand (2000)-Hour Limited Warranty

Your Kohler product has been manufactured and inspected with care by experienced craftsmen. If you are the original end user, Kohler Co. warrants, for the period indicated below, each product to be free from defects in materials and workmanship. In the event of a defect in materials or workmanship, Kohler Co. will repair, replace, or make appropriate adjustment at Kohler Co.'s option if the product, upon Kohler Co.'s inspection, is found to be properly installed, maintained, and operated in accordance with Kohler Co.'s instruction manuals. A Kohler distributor, dealer, or authorized service representative must perform startup.

Kohler Product

Stationary Standby Generator Set & Accessories

Warranty Coverage

One (1) year from registered startup or two thousand (2000) hours (whichever occurs first). In any event, the warranty period will expire not later than thirty (30) months from the date of shipment from Kohler Co.'s factory.

Stationary Prime Power Generator Set & Accessories

One (1) year from registered startup or two thousand (2000) hours (whichever occurs first). In any event, the warranty period will expire not later than thirty (30) months from the date of shipment from Kohler Co.'s factory.

The following will **not** be covered by the warranty:

1. Normal wear, routine tuneups, tuneup parts, adjustments, and periodic service.
2. Damage, including but not limited to damage caused by accidents, improper installation or handling, faulty repairs not performed by an authorized Kohler service representative, improper storage, or acts of God.
3. Damage caused by operation at speeds, or with fuel, loads, conditions, modifications or installation contrary to published specifications.
4. Damage caused by negligent maintenance such as:
 - a. Failure to provide the specified type and sufficient quantity of lubricating oil.
 - b. Failure to keep the air intake and cooling fin areas clean.
 - c. Failure to service the air cleaner.
 - d. Failure to provide sufficient coolant and/or cooling air.
 - e. Failure to perform scheduled maintenance as prescribed in supplied manuals.
 - f. Failure to regularly exercise the generator set under load (stationary applications only).
5. Original installation charges and startup costs.
6. Starting batteries and the following related expenses:
 - a. Labor charges related to battery service.
 - b. Travel expenses related to battery service.
7. Additional expenses for repairs performed after normal business hours, i.e. overtime or holiday labor rates.
8. Rental of equipment during the performance of warranty repairs.
9. Removal and replacement of non-Kohler-supplied options and equipment.
10. Non-Kohler replacement parts. Replacement of a failed Kohler part with a non-Kohler part voids the warranty on that part.
11. Radiators replaced rather than repaired.
12. Fuel injection pumps not repaired by an authorized Kohler service representative.
13. Non-Kohler-authorized repair shop labor without prior approval from Kohler Co. Warranty Department.
14. Engine fluids such as fuel, oil, or coolant/antifreeze.
15. Shop supplies such as adhesives, cleaning solvents, and rags.
16. Expenses incurred investigating performance complaints unless the problem is caused by defective Kohler materials or workmanship.
17. Maintenance items such as fuses, lamps, filters, spark plugs, loose or leaking clamps, and adjustments.
18. Travel time and mileage exceeding 300 miles round trip.

To obtain warranty service, call 1-800-544-2444 for your nearest authorized Kohler service representative or write Kohler Co., Service Department, MS072, Kohler, WI 53044 USA.

KOHLER CO. SHALL NOT BE LIABLE FOR SPECIAL, INCIDENTAL, AND/OR CONSEQUENTIAL DAMAGES OF ANY KIND including, but not limited to, incidental and/or consequential labor costs, installation charges, telephone charges, or transportation charges in connection with the replacement or repair of defective parts.

This is our exclusive written warranty. We make no other express warranty nor is anyone authorized to make any on our behalf.

ANY IMPLIED OR STATUTORY WARRANTY, INCLUDING ANY WARRANTY OF MERCHANTABILITY OR FITNESS FOR A PARTICULAR PURPOSE, IS EXPRESSLY LIMITED TO THE DURATION OF THIS WARRANTY. Some states do not allow limitations on how long an implied warranty lasts, or the exclusion or limitation of incidental and/or consequential damages, so the above limitation or exclusion may not apply to you.

This warranty gives you specific legal rights, and you may also have other rights which vary from state to state.

KOHLER®

KOHLER CO., Kohler, Wisconsin 53044
Phone 920-457-4441, Fax 920-459-1646
For the nearest sales/service outlet in the US and Canada, phone 1-800-544-2444
KOHLERPower.com

TP-5374 12/15f

Stationary Standby Industrial Generator Set Extended Five-Year or Three Thousand (3000)-Hour Comprehensive Limited Warranty

Your Kohler product has been manufactured and inspected with care by experienced craftsmen. If you are the original end user, Kohler Co. warrants, for the period indicated below, each product to be free from defects in materials and workmanship. In the event of a defect in materials or workmanship, Kohler Co. will repair, replace, or make appropriate adjustment at Kohler Co.'s option if the product, upon Kohler Co.'s inspection, is found to be properly installed, maintained, and operated in accordance with Kohler Co.'s instruction manuals. A Kohler distributor, dealer, or authorized service representative must perform startup.

Kohler Product

Stationary Standby Generator Set & Accessories

Warranty Coverage

Five (5) years from registered startup or three thousand (3000) hours (whichever occurs first).

This warranty is effective only upon Kohler Co.'s receipt of an extended warranty registration form and warranty fee within one year of registered startup. The comprehensive limited warranty start date is determined by the standard limited warranty requirements and runs concurrent with the standard limited warranty during the first year. To receive extended comprehensive limited warranty coverage, the provisions of the standard limited warranty registration must be met.

The following will **not** be covered by the warranty:

1. Normal wear, routine tuneups, tuneup parts, adjustments, and periodic service.
2. Damage, including but not limited to damage caused by accidents, improper installation or handling, faulty repairs not performed by an authorized Kohler service representative, improper storage, or acts of God.
3. Damage caused by operation at speeds, or with fuel, loads, conditions, modifications or installation contrary to published specifications.
4. Damage caused by negligent maintenance such as:
 - a. Failure to provide the specified type and sufficient quantity of lubricating oil.
 - b. Failure to keep the air intake and cooling fin areas clean.
 - c. Failure to service the air cleaner.
 - d. Failure to provide sufficient coolant and/or cooling air.
 - e. Failure to perform scheduled maintenance as prescribed in supplied manuals.
 - f. Failure to regularly exercise the generator set under load (stationary applications only).
5. Original installation charges and startup costs.
6. Starting batteries and the following related expenses:
 - a. Labor charges related to battery service.
 - b. Travel expenses related to battery service.
7. Engine coolant heaters, heater controls, and circulating pumps after the first year of the warranty period.
8. Additional expenses for repairs performed after normal business hours, i.e. overtime or holiday labor rates.
9. Rental of equipment during the performance of warranty repairs.
10. Removal and replacement of non-Kohler-supplied options and equipment.
11. Non-Kohler replacement parts. Replacement of a failed Kohler part with a non-Kohler part voids the warranty on that part.
12. Radiators replaced rather than repaired.
13. Fuel injection pumps not repaired by an authorized Kohler service representative.
14. Non-Kohler-authorized repair shop labor without prior approval from Kohler Co. Warranty Department.
15. Engine fluids such as fuel, oil, or coolant/antifreeze.
16. Shop supplies such as adhesives, cleaning solvents, and rags.
17. Expenses incurred investigating performance complaints unless the problem is caused by defective Kohler materials or workmanship.
18. Maintenance items such as fuses, lamps, filters, spark plugs, loose or leaking clamps, and adjustments.
19. Travel time and mileage exceeding 300 miles round trip.

To obtain warranty service, call 1-800-544-2444 for your nearest authorized Kohler service representative or write Kohler Co., Service Department, MS072, Kohler, WI 53044 USA.

KOHLER CO. SHALL NOT BE LIABLE FOR SPECIAL, INCIDENTAL, AND/OR CONSEQUENTIAL DAMAGES OF ANY KIND including, but not limited to, incidental and/or consequential labor costs, installation charges, telephone charges, or transportation charges in connection with the replacement or repair of defective parts.

This is our exclusive written warranty. We make no other express warranty nor is anyone authorized to make any on our behalf.

ANY IMPLIED OR STATUTORY WARRANTY, INCLUDING ANY WARRANTY OF MERCHANTABILITY OR FITNESS FOR A PARTICULAR PURPOSE, IS EXPRESSLY LIMITED TO THE DURATION OF THIS WARRANTY. Some states do not allow limitations on how long an implied warranty lasts, or the exclusion or limitation of incidental and/or consequential damages, so the above limitation or exclusion may not apply to you.

This warranty gives you specific legal rights, and you may also have other rights which vary from state to state.

KOHLER®

KOHLER CO., Kohler, Wisconsin 53044
Phone 920-457-4441, Fax 920-459-1646
For the nearest sales/service outlet in the
US and Canada, phone 1-800-544-2444
KOHLERPower.com

TP-5561 8/16f

KOHLER®

Certification

Certificate of Registration

QUALITY MANAGEMENT SYSTEM - ISO 9001:2015

This is to certify that:

Kohler Power Systems
N7650 Lakeshore Road
Sheboygan
Wisconsin
53083
USA

Holds Certificate No:

FM 727336

and operates a Quality Management System which complies with the requirements of ISO 9001:2015 for the following scope:

Design, manufacture, and distributor support for electrical generators, alternators, fuel tanks, automatic transfer switches and switchgear.

For and on behalf of BSI:



Carlos Pitanga, Chief Operating Officer Assurance – Americas

Original Registration Date: 1995-02-28

Latest Revision Date: 2021-10-29

Effective Date: 2021-11-07

Expiry Date: 2024-11-06

Page: 1 of 2



...making excellence a habit.™

Certificate No: **FM 727336**

Location	Registered Activities
Kohler Power Systems - GK 900 Highland Drive Bldg 604 Kohler Wisconsin 53004 USA	Manufacture of leads and harness, automatic transfer switches and switchgear. Distribution of generator sets.
Kohler Power Systems N7650 Lakeshore Road Sheboygan Wisconsin 53083 USA	Design, manufacture, and distributor support for electrical generators, automatic transfer switches and switchgear.
Kohler Power Systems 300 N Dekora Woods Blvd Saukville Wisconsin 53080 USA	Manufacture of fuel tanks, skids, fabricated components and generators.
Kohler Power Systems Muth Warehouse 2821 Muth Court Sheboygan Wisconsin 53083 USA	The distribution of generator sets.
Kohler Power Systems KWIP Warehouse 4327 County EE Sheboygan Wisconsin 53081 USA	Receiving, sequencing and warehousing of generator components.

Original Registration Date: 1995-02-28

Latest Revision Date: 2021-10-29

Effective Date: 2021-11-07

Expiry Date: 2024-11-06

Page: 2 of 2

This certificate remains the property of BSI and shall be returned immediately upon request.

An electronic certificate can be authenticated [online](https://www.bsigroup.com/ClientDirectory). Printed copies can be validated at www.bsigroup.com/ClientDirectory
To be read in conjunction with the scope above or the attached appendix.

Information and Contact: BSI, Kitemark Court, Davy Avenue, Knowlhill, Milton Keynes MK5 8PR. Tel: + 44 345 080 9000
BSI Assurance UK Limited, registered in England under number 7805321 at 389 Chiswick High Road, London W4 4AL, UK.
A Member of the BSI Group of Companies.

G15-152 10/21

PROTOTYPE TEST REPORT



Models Covered: **40, 50, 60REOZK**
Model Tested: **60REOZK**
Cooling System Tested: **50C**

Alternator Tested: **4Q10X**
Engine Tested: **KDI3404TM**
Voltage Tested: **240V**

GENSET

Maximum power test to assure that the prime mover and alternator have sufficient capacity to operate within specifications.

Meets Rated Load

Steady-state load test to ensure voltage stability meets or exceeds ISO8528-5 requirements and to verify compliance with steady state speed control specifications.

± 0.50 % Frequency Band

± 0.50 % Voltage Deviation

Transient load tests per NEMA MG1-32.18, and ISO 8528 to verify specifications of transient voltage regulation, voltage dip, voltage overshoot, recovery voltage, and recovery time. Values shown for model tested above. Please contact factory for additional details.

Full Load Acceptance

36.7 % Voltage Dip

1.20 Seconds of Recovery Time

16.1 % Frequency Dip

3.30 Seconds of Recovery Time

Full Load Rejection

13.8 % Voltage Overshoot

0.50 Seconds of Recovery Time

10.6 % Frequency Overshoot

2.60 Seconds of Recovery Time

G2 ISO8528-5 Class (G1, G2, G3)

NFPA 110 one step testing to determine the amount of time required for the generator set to reach 90% voltage and frequency to allow the ATS to transfer.

Complies with NFPA 110 Type 10

Vibrational analysis to verify that generator vibrations are within acceptable limits per ISO 8528-9.

Complies

Torsional analysis data to verify torsional effects are not detrimental and that the generator set will provide dependable service as specified.

Complies

Generator set cooling and air flow tests to verify maximum operating ambient temperature. (Cooling system test results are available on TIB-118)

Acoustical noise intensity and sound attenuation effects tests (Acoustical noise results are available on TIB-114 & 115)

Exhaust Back Pressure test completed to demonstrate within engine limitation (Exhaust back pressure test results are available on TIB-119)

Models Covered: **40, 50, 60REOZK**
Model Tested: **60REOZK**
Cooling System Tested: **50C**

Alternator Tested: **4Q10X**
Engine Tested: **KDI3404TM**
Voltage Tested: **240V**

ALTERNATOR

Alternator temperature rise test per NEMA MG1-32.6. Standby and prime ratings of the alternator are established during this test.

Alternator overload test per NEMA MG1-32.8. Motor starting tests per NEMA MG1-32.18.5 to evaluate capabilities of generator, exciter, and regulator system.

Three-phase symmetrical short-circuit test per NEMA MG1-32.13 to demonstrate short circuit performance, mechanical integrity, ability to sustain short-circuit current.

Harmonic analysis, voltage waveform deviation per NEMA MG1-32.10 to confirm that the generator set is producing clean voltage within acceptable limits.

(Alternator detailed test results are available on TIB-102)

Kohler Standby/Prime Generator Set Test Program

Testing is an integral part of quality assurance. In keeping with our uncompromising commitment to quality, safety, and reliability, every Kohler Standby/Prime power generator set undergoes an extensive series of prototype and production testing.

Prototype Testing

Prototype testing includes the potentially destructive tests necessary to verify design, proper function of protective devices and safety features, and reliability expectations. Kohler's prototype testing includes the following:

- Alternator temperature rise test per NEMA MG1-32.6. Standby and prime ratings of the alternator are established during this test.
- Maximum power test to assure that the prime mover and alternator have sufficient capacity to operate within specifications.
- Alternator overload test per NEMA MG1-32.8.
- Steady-state load test to ensure voltage regulation meets or exceeds ANSI C84.1, NEMA MG1-32.17 requirements and to verify compliance with steady-state speed control specifications.
- Transient test to verify speed controls meets or exceeds specifications.
- Transient load tests per NEMA MG1-32.18, and ISO 8528 to verify specifications of transient voltage regulation, voltage dip, voltage overshoot, recovery voltage, and recovery time.
- Motor starting tests per NEMA MG1-32.18.5 to evaluate capabilities of generator, exciter, and regulator system.
- Three-phase symmetrical short-circuit test per NEMA MG1-32.13 to demonstrate short circuit performance, mechanical integrity, ability to sustain short-circuit current.
- Harmonic analysis, voltage waveform deviation per NEMA MG1-32.10 to confirm that the generator set is producing clean voltage within acceptable limits.

Torsional analysis data, to verify torsional effects are not detrimental and that the generator set will provide dependable service as specified, is available upon request.

Kohler offers other testing at the customer's request at an additional charge. These optional tests include power factor testing, customized load testing for specific application, witness testing, and a broad range of MIL-STD-705c testing. A certified test report is also available at an additional charge.

- Generator set cooling and air flow tests to verify maximum operating ambient temperature.
- Reliability tests to demonstrate product durability, followed by root cause analysis of discovered failures and defects. Corrective action is taken to improve the design, workmanship, or components.
- Acoustical noise intensity and sound attenuation effects tests.

Production Testing

In production, Kohler Standby/Prime generator sets are built to the stringent standards established by the prototype program. Every Kohler generator set is fully tested prior to leaving the factory. Production testing includes the following:

- Stator and exciter winding high-potential test on all generators. Surge transient tests on stators for generators 180 kW or larger. Continuity and balance tests on all rotors.
- One-step, full-load pickup tests to verify that the performance of each generator set, regulator, and governor meets published specifications.
- Regulation and stability of voltage and frequency are tested and verified at no load, 1/4 load, 1/2 load, 3/4 load, and full-rated load.
- Voltage, amperage, frequency and power output ratings verified by full-load test.
- The proper operation of controller logic circuitry, prealarm warnings, and shutdown functions is tested and verified.
- Any defect or variation from specification discovered during testing is corrected and retested prior to approval for shipment to the customer.

KOHLER[®]

KOHLER CO. Kohler, Wisconsin 53044
Phone 920-565-3381, Fax 920-459-1646
For the nearest sales/service outlet in the
US and Canada, phone 1-800-544-2444
KohlerPowerSystems.com