

# Submittal Package

---

## Generator

---

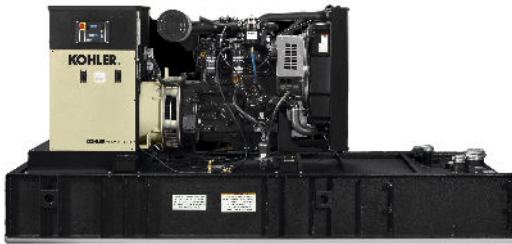

### Kohler Model: 100REOZJF

This diesel generator set equipped with a 4R9X alternator operating at 120/208 volts is rated for 100 kW/125 kVA. Output amperage: 347

### Standard Features:

- Kohler Co. provides one-source responsibility for the generating system and accessories.
- The generator set and its components are prototype-tested, factory-built, and production-tested.
- The 60 Hz generator set offers a UL 2200 listing.
- The generator set accepts rated load in one step.
- The 60 Hz generator set meets NFPA 110, Level 1, when equipped with the necessary accessories and installed per NFPA standards.
- A one-year limited warranty covers all systems and components. Two-, five-, and ten-year extended warranties are also available.
- Tier 3 EPA-certified for Stationary Emergency Applications
- Alternator Protection
- Battery Rack and Cables
- Customer Connection (standard with Decision-Maker 6000 controller only)
- Local Emergency Stop Switch
- Oil Drain Extension

### Other Features:

- Kohler designed controller for guaranteed system integration and remote communication.
- The low coolant level shutdown prevents overheating (standard on radiator models only).
- Integral vibration isolation eliminates the need for under-unit vibration spring isolators.
- Mount up to three circuit breakers to allow circuit protection of selected priority loads.

### Alternator Features:

- Operation and Installation Literature
- The unique Fast-Response X excitation system delivers excellent voltage response and short circuit capability using a rare-earth, permanent magnet (PM)-excited alternator.

Qty	Description
	100REOZJF Generator System
15	100REOZJF Generator Set
	<b>Includes the following:</b>
	Literature Languages English
	Approvals and Listings UL2200 Listing
	Engine 100REOZJF, 12V, 60Hz
	Nameplate Rating Standby 130C Rise
	Voltage 60Hz, 120/208V, Wye, 3Ph, 4W
	Alternator 4R9X
	Cooling System Unit Mounted Radiator, 50C
	Skid and Mounting Skid/Tank
	Air Intake Standard Duty
	Controller APM402
	Enclosure Type Sound
	Enclosure Material Steel
	Enclosure Silencer Internal Silencer
	Fuel Tank Type Standard
	Fuel Runtime (Approx.) 24 Hours
	Subbase Fuel Tank Capacity 209 Gallons
	Fuel Tank Options Inner Tank Leak Alarm
	Starting Aids, Installed 1500W,120V
	Electrical Accy.,Installed Battery, 1/12V, Wet
	Electrical Accy.,Installed Battery Charger, 6A
	Rating, LCB 1 100% Rated
	Amps, LCB 1 400
	Trip Type, LCB 1 Electronic, LSI
	Interrupt Rating LCB 1 35kA at 480V
	Fuel Lines, Installed Flexible Fuel Lines
	Miscellaneous Accy,Installed Coolant in Genset
	Warranty 5 Year Comprehensive
	Testing, Additional Power Factor Test,0.8,3Ph Only
15	Lit Kit, General Maint, 100REOZJF

**KOHLER®**

# Spec Sheets

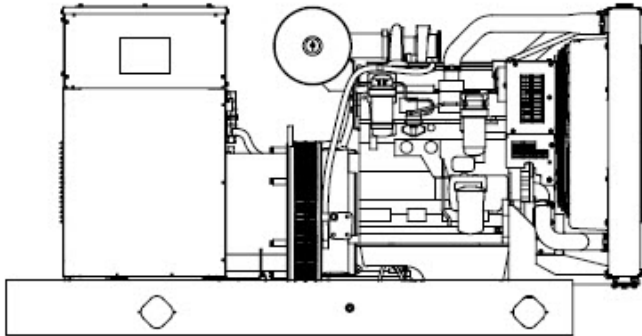

## Standard Features

- Kohler Co. provides one-source responsibility for the generating system and accessories.
- The generator set and its components are prototype-tested, factory-built, and production-tested.
- The 60 Hz generator set offers a UL 2200 listing.
- The generator set accepts rated load in one step.
- The 60 Hz generator set meets NFPA 110, Level 1, when equipped with the necessary accessories and installed per NFPA standards.
- A one-year limited warranty covers all systems and components. Two-, five-, and ten-year extended warranties are also available.
- Tier 3 EPA-certified for Stationary Emergency Applications
- Alternator Protection
- Battery Rack and Cables
- Customer Connection (standard with Decision-Maker 6000 controller only)
- Local Emergency Stop Switch
- Oil Drain Extension

## Alternator Features

- Operation and Installation Literature
- The unique Fast-Response X excitation system delivers excellent voltage response and short circuit capability using a rare-earth, permanent magnet (PM)-excited alternator.

## Other Features

- Kohler designed controller for guaranteed system integration and remote communication.
- The low coolant level shutdown prevents overheating (standard on radiator models only).
- Integral vibration isolation eliminates the need for under-unit vibration spring isolators.
- Mount up to three circuit breakers to allow circuit protection of selected priority loads.

## Generator Set Rating

## Standby 130C Rise Ratings

Alternator	Voltage	Ph	Hz	Peak kVA	kW/kVA	Amps
4R9X	120/208	3	60	290	100/125	347

RATINGS: All three-phase units are rated at 0.8 power factor. All single-phase units are rated at 1.0 power factor.  
 Standby Ratings: The standby rating is applicable to varying loads for the duration of a power outage. There is no overload capability for this rating.  
 Prime Power Ratings: At varying load, the number of generator set operating hours is unlimited. A 10% overload capacity is available for one hour in twelve.  
 Ratings are in accordance with ISO-8528-1 and ISO-3046-1. For limited running time and continuous ratings, consult the factory.  
 Obtain technical information bulletin (TIB-101) for ratings guidelines, complete ratings definitions, and site condition derates.  
 The generator set manufacturer reserves the right to change the design or specifications without notice and without any obligation or liability whatsoever.

## Model: 100REOZJF, continued

### Alternator Specifications

Specifications	Alternator
Alternator manufacturer	Kohler
Type	4-Pole, Rotating-Field
Exciter type	Brushless, Rare-Earth Permanent-Magnet
Leads, quantity	12, Reconnectable
Voltage regulator	Solid State, Volts/Hz
Insulation	NEMA MG1
Insulation: Material	Class H
Insulation: Temperature Rise	130°C, Standby
Bearing: quantity, type	1, Sealed
Coupling	Flexible disc
Amortisseur windings	Full
Voltage regulation, no-load to full-load RMS	Controller Dependent
One-Step Load Acceptance	100% of rating
Unbalanced load capability	100% of Rated Standby Current

- NEMA MG1, IEEE, and ANSI standards compliance for temperature rise and motor starting.
- Sustained short-circuit current of up to 300% of the rated current for up to 10 seconds.
- Sustained short-circuit current enabling down stream circuit breakers to trip without collapsing the alternator field.
- Self-ventilated and dripproof construction.
- Vacuum-impregnated windings with fungus-resistant epoxy varnish for dependability and long life.
- Superior voltage waveform from a two-thirds pitch stator and skewed rotor.

### Engine

#### Engine Specification

Engine Manufacturer	John Deere
Engine Model	4045HF285I
Engine: type	4-Cycle, Turbocharged, Charge Air-Cooled
Cylinder arrangement	4 Inline
Displacement, L (cu. in.)	4.5 (276)
Bore and stroke, mm (in.)	106 x 127 (4.19 x 5.00)
Compression ratio	19:01
Piston speed, m/min. (ft./min.)	457 (1500)
Main bearings: quantity, type	5, Replaceable Insert
Rated rpm	1800
Max. power at rated rpm, kWm (BHP)	118 (158)
Cylinder head material	Cast Iron
Crankshaft material	Forged Steel
Valve (exhaust) material Intake	Chromium-Silicon Steel
Valve (exhaust) material	Stainless Steel
Governor: type, make/model	JDEC Electronic L16 Denso HP3
Frequency regulation, no-load to-full load	Isochronous
Frequency regulation, steady state	±0.25%
Frequency	Fixed
Air cleaner type, all models	Dry

## Model: 100REOZJF, continued

### Exhaust

#### Exhaust System

Exhaust Manifold Type	Dry
Exhaust flow at rated kW, m <sup>3</sup> /min. (cfm)	22.8 (805)
Exhaust temperature at rated kW, dry exhaust, °C (°F)	580 (1076)
Maximum allowable back pressure, kPa (in. Hg)	7.5 (2.2)
Exh. outlet size at eng. hookup, mm (in.)	98 (3.86)

### Engine Electrical

#### Engine Electrical System

Battery charging alternator	12 Volt
Battery charging alternator: Ground (negative/positive)	Negative
Battery charging alternator: Volts (DC)	12
Battery charging alternator: Ampere rating	65
Starter motor rated voltage (DC)	12
Battery, recommended cold cranking amps (CCA): Qty., CCA rating each	One, 640
Battery voltage (DC)	12

### Fuel

#### Fuel System

Fuel type	Diesel
Fuel supply line, min. ID, mm (in.)	11.0 (0.44)
Fuel return line, min. ID, mm (in.)	6.0 (0.25)
Max. lift, fuel pump: type, m (ft.)	Engine-Driven, 1.8 (6.0)
Max. fuel flow, Lph (gph)	74.6 (19.7)
Max. return line restriction, kPa (in. Hg)	20 (5.9)
Fuel prime pump	Manual
Fuel Filter Secondary	2 Microns@ 98% Efficiency
Fuel Filter Primary	30 Microns
Fuel Filter Water Separator	Yes
Recommended fuel	#2 Diesel

### Lubrication

#### Lubrication System

Type	Full Pressure
Oil pan capacity, L (qt.)	14.7 (15.5)
Oil pan capacity with filter, L (qt.)	15.6 (16.5)
Oil filter: quantity, type	1, Cartridge
Oil cooler	Water-Cooled

## Model: 100REOZJF, continued

### Cooling

#### Radiator System

Ambient temperature, °C (°F)	50 (122)
Engine jacket water capacity, L (gal.)	8.5 (2.25)
Radiator system capacity, including engine, L (gal.)	20.1 (5.3)
Engine jacket water flow, Lpm (gpm)	182 (48)
Heat rejected to cooling water at rated kW, dry exhaust, kW (Btu/min.)	62 (3544)
Heat rejected to air charge cooler at rated kW, dry exhaust, kW (Btu/min.)	20 (1127)
Water pump type	Centrifugal
Fan diameter, including blades, mm (in.)	600 (23.6)
Fan, kWm (HP)	6.6 (8.8)
Max. restriction of cooling air, intake and discharge side of radiator, kPA (in. H2O)	0.125 (0.5)

\* Enclosure with internal silencer reduces ambient temperature capability by 5°C (9°F).

### Operation Requirements

#### Air Requirements

Radiator-cooled cooling air, m3/min. (scfm) *	142 (5000)
Combustion air, m3/min. (cfm)	8.2 (288)
Heat rejected to ambient air: Engine, kW (Btu/min.)	25.0 (1420)
Heat rejected to ambient air: Alternator, kW (Btu/min.)	11.6 (660)

\*Air density = 1.20 kg/m<sup>3</sup> (0.075 lbm/ft<sup>3</sup>)

### Fuel Consumption

#### Diesel, Lph (gph), at % load

#### Rating

Standby Fuel Consumption at 100% load	31.0 Lph (8.2 gph)
Standby Fuel Consumption at 75% load	25.0 Lph (6.6 gph)
Standby Fuel Consumption at 50% load	17.8 Lph (4.7 gph)
Standby Fuel Consumption at 25% load	9.5 Lph (2.5 gph)



**Kohler® APM402 Controller****General Description and Function**

The APM402 generator set controller provides advanced control, system monitoring, and system diagnostics for optimum performance.

The APM402 controller meets NFPA 110, Level 1 when equipped with the necessary accessories and installed per NFPA standards.

The APM402 controller uses a patented hybrid voltage regulator and unique software logic to manage alternator thermal overload protection features normally requiring additional hardware. Additional features include:

- A digital display and pushbutton/rotary selector dial provide easy local access to data.
- Measurements selectable in metric or English units.
- The controller can communicate directly with a personal computer via a network or serial configuration using SiteTech™ or Monitor III software.
- The controller supports Modbus® protocol. Use with serial bus or Ethernet networks. (Ethernet requires an external Modbus®/Ethernet converter module.)
- Scrolling display shows critical data at a glance.
- Digital display of power metering (kW and kVA).
- Integrated hybrid voltage regulator providing  $\pm 0.5\%$  regulation.
- Built-in alternator thermal overload protection.

Modbus® is a registered trademark of Schneider Electric.

**APM402**

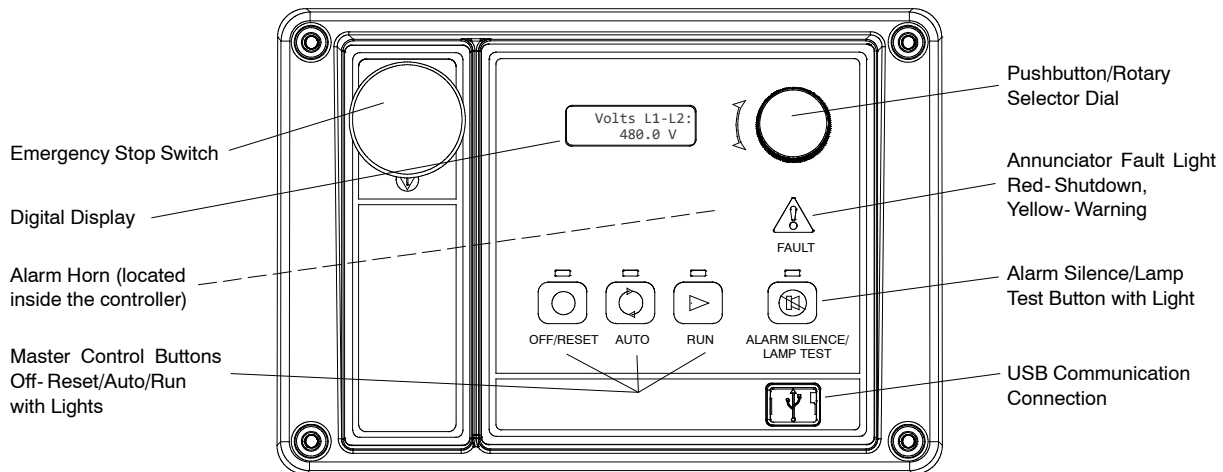

## User Interface Controls and Components

- Emergency stop switch
- Backlit LCD digital display with two lines of 12 characters (see *User Interface Displays for menus*)
- Alarm horn indicates generator set shutdown and warning faults
- Environmentally sealed membrane keypad with three master control buttons with lights
  - Off/Reset (red)
  - Auto (green)
  - Run (yellow)
- Pushbutton/rotary selector dial for menu navigation
  - Rotate dial to access main menus
  - Push dial and rotate to access sub menus
  - Press dial for 3 seconds to return to top of main menu
- Annunciator fault light
  - System shutdown (red)
  - System warning (yellow)
- Alarm silence/lamp test button
  - Alarm silence
  - Lamp test
- USB and RS-485 connections
  - Allows software upgrades
  - Provides access for diagnostics
  - PC communication using SiteTech™ or Monitor III software
- Dedicated user inputs
  - Remote emergency stop switch
  - Remote 2-wire start for transfer switch
  - Auxiliary shutdown
- Integrated hybrid voltage regulator
- Auto-resettable circuit protection mounted on circuit board.
- One relay output standard. Optional five relay output available.
- One analog and three digital inputs standard. Optional two inputs available.

## NFPA 110 Requirements

In order to meet NFPA 110, Level 1 requirements, the generator set controller monitors the engine/generator functions/faults shown below.

- Engine functions:
  - Overcrank
  - Low coolant temperature warning
  - High coolant temperature warning
  - High coolant temperature shutdown
  - Low oil pressure shutdown
  - Low oil pressure warning
  - High engine speed
  - Low fuel (level or pressure) \*
  - Low coolant level
  - EPS supplying load
  - High battery voltage
  - Low battery voltage
- General functions:
  - Master switch not in auto
  - Battery charger fault \*
  - Lamp test
  - Contacts for local and remote common alarm
  - Audible alarm silence button
  - Remote emergency stop \*

\* Function requires optional input sensors or kits and is engine dependent, see Controller Displays as Provided by the Engine ECM.

## User Interface Displays

The listing below has ● denoting main menus and ○ denoting sub-menus.

- Overview
  - Software version
  - Active shutdowns and warnings (if any are present)
  - Engine run time, total hours
  - Average voltage line-to-line
  - Frequency
  - Average current
  - Coolant temperature
  - Fuel level or pressure \*
  - Oil pressure
  - Battery voltage
- Engine Metering
  - Engine speed
  - Oil pressure
  - Coolant temperature
  - Battery voltage
- Generator Metering
  - Total power, VA
  - Total power, W
  - Rated power, %
  - Voltage, L-L and L-N for all phases
  - Current, L1, L2, L3
  - Frequency
- GenSet Information
  - Generator set model number
  - Generator set serial number
  - Controller serial number
- GenSet Run Time
  - Engine run time, total hours
  - Engine loaded, hours
  - Number of engine starts
  - Total energy, kWh
- GenSet System
  - System voltage
  - System frequency, 50 or 60 Hz
  - System phase, single or three (wye or delta)
  - Power rating, kW
  - Amp rating
  - Power type, standby or prime
  - Measurement units, metric or English (user selectable)
  - Alarm silence, always or auto only (NFPA 110)
  - Manual speed adjust \*
- GenSet Calibration
  - Voltage, L-L and L-N for all phases
  - Current, L1, L2, L3
  - Reset calibration
- Voltage Regulation
  - Adjust voltage, ±10%
- Digital Inputs
  - Input settings and status
- Digital Outputs
  - Output settings and status
- Analog Inputs
  - Input settings and status
- Event Log
  - Event history (stores up to 1000 system events)
- Selector Switch (requires initial activation by SiteTech™)

## Controller Features

- **AC Output Voltage Regulator Adjustment.** The voltage adjustment provides a maximum of  $\pm 10\%$  of the system voltage.
- **Alarm Silence.** The controller can be set up to silence the alarm horn only when in the AUTO mode for NFPA-110 application or Always for user convenience.
- **Alternator Protection.** The controller provides generator set overload and short circuit protection matched to each alternator for the particular voltage/phase configuration.
- **Automatic Restart.** The controller automatic restart feature initiates the start routine and re crank after a failed start attempt.
- **Common Failure Relay.** This relay is integrated on the controller circuit board. Contacts are rated 2 amps at 32 VDC or 0.5 amp at 120 VAC.
- **Communication.** Controller communication is available.
- **Cyclic Cranking.** The controller has programmable cyclic cranking.
- **ECM Diagnostics.** The controller displays engine ECM fault code descriptions to help in engine troubleshooting.
- **Engine Start Aid.** The starting aid feature provides control for an optional engine starting aid.
- **Event Logging.** The controller keeps a record (up to 1000 entries) for warning and shutdown faults. This fault information becomes a stored record of system events and can be reset.
- **Historical Data Logging.** Total number of generator set successful starts is recorded and displayed.
- **Integrated Hybrid Voltage Regulator.** The voltage regulator provides  $\pm 0.5\%$  no-load to full-load regulation with three-phase sensing.
- **Lamp Test.** Press the alarm silence/lamp test button to verify functionality of the indicator lights.
- **LCD Display.** Adjustable contrast for improving visibility.
- **Measurement Units.** The controller provides selection of English or metric displays.
- **Power Metering.** Controller digital display provides kW and kVA.
- **Programming Access (USB).** Provides software upgrades and diagnostics.
- **Remote Reset.** The remote reset function resets faults and allows restarting of the generator set without going to the master control switch off/reset position.
- **Remote Monitoring Panel.** The controller is compatible with the Kohler® Remote Serial Annunciator.
- **Run Time Hourmeter.** The generator set run time is displayed.
- **Time Delay Engine Cooldown (TDEC).** The TDEC provides a time delay before the generator set shuts down.
- **Time Delay Engine Start (TDES).** The TDES provides a time delay before the generator set starts.
- **Voltage Selection Menu.** This menu provides the capability of quickly switching controller voltage calibrations. Requires initial activation using SiteTech™ software. **NOTE:** Generator set output leads require voltage reconnection.

## Controller Functions

The following chart shows which functions cause a warning or shutdown. All functions are available as relay outputs.

**Warning** causes the fault light to show yellow and sounds the alarm horn signaling an impending problem.

**Shutdown** causes the fault light to show red, sounds the alarm horn, and stops the generator set.

	Warning Function	Shutdown Function
<b>Engine Functions</b>		
Critically high fuel level *	○	
ECM communication loss		●
ECM diagnostics	●	●
Engine over speed		●†
Engine start aid active		
Engine under speed		●
Fuel tank leak *	○	○
High battery voltage	●	
High coolant temperature	●	●†
High fuel level *	○	
Low battery voltage	●	
Low coolant level		●
Low coolant temperature	●	
Low cranking voltage	●	
Low engine oil level *	○	○
Low fuel level (diesel models) *	○	○
Low fuel pressure (gas models) *	○	
Low oil pressure	●	●†
No coolant temperature signal		●
No oil pressure signal		●
Overcrank		●†
Speed sensor fault	●	
<b>General Functions</b>		
Alarm horn silenced		
Analog inputs	○	○
Battery charger fault *	●	
Chicago code active *		
Common fault (includes †)		●
Common warning	●	
Digital inputs	○	○
Emergency stop		●†
Engine cooldown (delay) active		
Engine start delay active		
Engine started		
Engine stopped		
EPS supplying load		
Generator running		
Input/output communication loss	●	
Internal failure		●
Master switch not in auto	●	
NFPA 110 alarm active		
Remote start		
System ready		
<b>Generator Functions</b>		
AC sensing loss	●	●
Alternator protection		●
Ground fault input *	●	
kW overload		●
Locked rotor		●
Overfrequency		●
Overvoltage (each phase)		●
Underfrequency		●
Undervoltage (each phase)		●

● Standard function

○ Available user function

\* Function requires optional input sensors or kits and is engine dependent; see Controller Displays as Provided by the Engine ECM.

† Items included with common fault shutdown



KOHLER CO., Kohler, Wisconsin 53044 USA  
 Phone 920-457-4441, Fax 920-459-1646  
 For the nearest sales and service outlet in the  
 US and Canada, phone 1-800-544-2444  
 KOHLERPower.com

Controller Displays as Provided by the Engine ECM	Engine Manufacturer (and Model)						
	Kohler Diesel (KDI M, TM*)	Kohler Diesel (KDI TCR)	Kohler Gas (KG2204, KG2204T)	Kohler Gas (KG6208, KG6208T, KG10V08, KG10V08T)	GM and PSI/Doosan	John Deere	Volvo
Intake air pressure							D
Intake air Temperature		D		D	D	D	D
Coolant level			D	D	D	D	D
Coolant temperature		D	C/S/D	C/S/D	C/S/D	C/S/D	C/S/D
Crankcase pressure							D
ECM battery voltage	S		S/D	S	S		
Engine speed	C/S/D	C/S/D	C/S/D	C/S/D	C/S/D	C/S/D	C/S/D
Fuel pressure		D		C/S/D	C/S/D	C/S†	C/S/D
Fuel temperature		D				S/D	S
Oil level				S†	S†	S†	S†
Oil pressure		C/S/D	D	C/S/D	C/S/D	C/S/D	C/S/D
Oil temperature			S				SD

C = Value displayed on controller, S = Value displayed in Site Tech, D = ECU diagnostic is supported  
 \* Electronic governor and ECM are optional on KDI M and TM engines.  
 † Controller uses local analog input to obtain this information.

**Note:** REOZMD/ROZMC (Mitsubishi engines) have an ECM but do not send signals to the generator set controller.

**Note:** See the generator set specification sheet for engine model identification.

### Controller Specifications

- Power source with circuit protection: 12- or 24-volt DC
- Power drain: 200 milliamps at 12 VDC or 100 milliamps at 24 VDC
- Humidity range: 5% to 95% noncondensing
- Operating temperature range: -40°C to +70°C (-40°F to +158°F)
- Storage temperature range: -40°C to +85°C (-40°F to +185°F)
- Standards:
  - CE Directive
  - NFPA 99
  - NFPA 110, Level 1
  - CSA 282-09
  - UL 508
  - ASTM B117 (salt spray test)
- Panel dimensions—W x H, 229 x 160 mm (9.0 x 6.3 in.)

### Communication and PC Software Available Options

Refer to G6-76 Monitor III Software and the communication literature for additional communication and PC software information including Modbus® communication.

- Monitor III Software for Monitoring and Control (Windows®-based user interface)**
- Converter, Modbus®/Ethernet.** Supports a power system using controllers accessed via the Ethernet. Converter is supplied with an IP address by the site administrator. Refer to G6-79 for converter details.
- Converter, RS-232/RS-485.** Supports a power system using controllers accessed via a serial (RS-232) connection.

### APM402 Available Options

- Float/Equalize Battery Charger** available with 6 or 10 amp output for 12 or 24V DC voltage output. The 10 amp model provides NFPA 110 charging and alarming capability.
- Manual Speed Adjust** available for applications using closed transition ATS. Adjustment range for 60 Hz: 1751- 1849 rpm (58.2- 61.8 Hz) and for 50 Hz: 1451- 1549 rpm (48.2- 51.8 Hz).
- Prime Power Switch** prevents battery drain during generator set non-operation periods and when the generator set battery cannot be maintained by an AC battery charger.
- Remote Emergency Stop Switch** available as a wall mounted panel to remotely shut down the generator set.
- Remote Monitoring Panel.** The Kohler® Remote Serial Annunciator (RSA) enables the operator to monitor the status of the generator set from a remote location, which may be required for NFPA 99 and NFPA 110 installations, and up to four Automatic transfer switches.
- Run Relay** provides a relay indicating that the generator set is running.
- Shunt Trip Wiring** provides relay outputs to trip a shunt trip circuit breaker and to signal the common fault shutdowns. Contacts rated at 10 amps at 28 VDC or 120 VAC.
- Two Input/Five Output Module** provides a generator set mounted panel with two inputs and five relay outputs.

Windows® is a registered trademark of Microsoft Corporation.  
 Modbus® is a registered trademark of Schneider Electric.

**DISTRIBUTED BY:**

Availability is subject to change without notice. Kohler Co. reserves the right to change the design or specifications without notice and without any obligation or liability whatsoever. Contact your local Kohler® generator set distributor for availability.

© 2018 Kohler Co., All rights reserved.

### Line Circuit Breakers 15-3250 kW

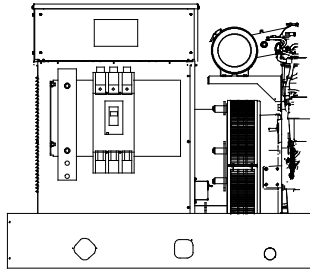

Single Circuit Breaker Kit with Neutral Bus Bar  
15-300 kW Model Shown

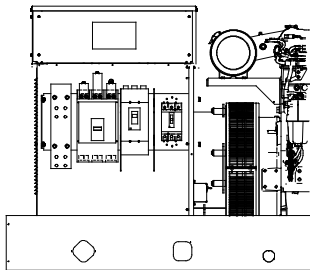

Multiple Circuit Breaker Kit with Neutral Bus Bar  
180-300 kW Model Shown

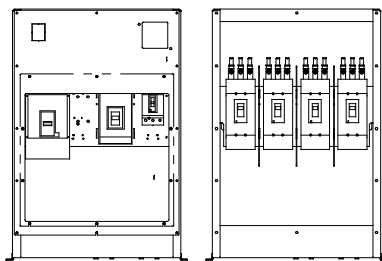

Multiple Circuit Breaker Kits with Neutral Bus Bar  
350-2250 kW Model Shown  
(also applies to some 300 kW models)

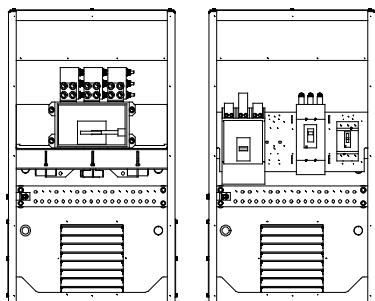

Circuit Breaker Kits with Neutral Bus Bar  
800-2500 kW KD Model Shown

### Standard Features

- The line circuit breaker interrupts the generator set output during a short circuit and protects the wiring when an overload occurs. Use the circuit breaker to manually disconnect the generator set from the load during generator set service.
- Circuit breaker kits are mounted to the generator set and are provided with load-side lugs and neutral bus bar.
- Kohler Co. offers a wide selection of molded-case line circuit breaker kits including single, dual, and multiple configurations for each generator set.
- Four types of line circuit breakers are available: (see page 2 for definitions and pages 3 and 4 for application details)
  - Magnetic trip
  - Thermal magnetic trip
  - **Electronic trip**
  - Electronic with ground fault (LSIG) trip
- In addition, line circuit breakers are offered with 80% and 100% ratings.
- Single line circuit breaker kits allow circuit protection of the entire electrical system load.
- Dual line circuit breaker kits allow circuit protection of selected priority loads from the remaining electrical system load.
- Multiple line circuit breaker kits with field connection barrier allow circuit protection for special applications (350- 2500 kW models and selected 80- 300 kW models).
- Up to four line circuit breakers can be used on 350- 2500 kW models.
- Line circuit breakers comply with the following codes and standards unless otherwise stated.
  - UL 489 Molded Case Circuit Breakers
  - UL 1077 Supplementary Protectors
  - UL 2200 Stationary Engine Generator Assemblies

## Line Circuit Breaker Types

### Magnetic Trip

The magnetic trip features an electromagnet in series with the load contacts and a moveable armature to activate the trip mechanism. When a sudden and excessive current such as a short circuit occurs, the electromagnet attracts the armature resulting in an instantaneous trip.

### Thermal Magnetic Trip

Thermal magnetic trip contains a thermal portion with a bimetallic strip that reacts to the heat produced from the load current. Excessive current causes it to bend sufficiently to trip the mechanism. The trip delay is dependent on the duration and excess of the overload current. Elements are factory-calibrated. A combination of both thermal and magnetic features allows a delayed trip on an overload and an instantaneous trip on a short circuit condition.

### Electronic Trip

These line circuit breakers use electronic controls and miniature current transformers to monitor electrical currents and trip when preset limits are exceeded.

LI breakers are a combination of adjustable trip functions including long-time ampere rating, long-time delay, and instantaneous pickup. LSI breakers have all of the LI breaker features plus short-time pickup, short-time delay, and defeatable instantaneous pickup. LSIG breakers have all of the LSI breaker features plus ground-fault pickup and delay.

**NOTE:** MG-frame does not have a long-time delay when selected with LI breakers.

### Electronic with Ground Fault Trip

The ground fault trip feature is referred to as LSIG in this document. Models with LSIG compare current flow in phase and neutral lines, and trip when current unbalance exists.

Ground fault trip units are an integral part of the circuit breaker and are not available as field-installable kits. The ground fault pickup switch sets the current level at which the circuit breaker will trip after the ground fault delay. Ground fault pickup values are based on circuit breaker sensor plug only and not on the rating plug multiplier. Changing the rating plug multiplier has no effect on the ground fault pickup values.

### 80% Rated Circuit Breaker

Most molded-case circuit breakers are 80% rated devices. An 80% rated circuit breaker can only be applied at 80% of its rating for continuous loads as defined by NFPA 70. Circuit conductors used with 80% rated circuit breakers are required to be rated for 100% of the circuit breaker's rating.

The 80% rated circuit breakers are typically at a lower cost than the 100% rated circuit breaker but load growth is limited.

### 100% Rated Circuit Breaker

Applications where all UL and NEC restrictions are met can use 100% rated circuit breakers where 100% rated circuits can carry 100% of the circuit breaker and conductor current rating.

The 100% rated circuit breakers are typically at a higher cost than the 80% rated circuit breaker but have load growth possibilities.

When applying 100% rated circuit breakers, comply with the various restrictions including UL Standard 489 and NEC Section 210. If any of the 100% rated circuit breaker restrictions are not met, the circuit breaker becomes an 80% rated circuit breaker.

## Line Circuit Breaker Options

### Alarm Switch

The alarm switch indicates that the circuit breaker is in a tripped position caused by an overload, short circuit, ground fault, the operation of the shunt trip, an undervoltage trip, or the push-to-trip pushbutton. The alarm resets when the circuit breaker is reset.

### Auxiliary Contacts

These switches send a signal indicating whether the main circuit breaker contacts are in the open or closed position.

### Breaker Separators (350- 2500 kW)

Provides adequate clearance between breaker circuits.

### Bus Bars

Bus bar kits offer a convenient way to connect load leads to the generator set when a circuit breaker is not present. **15- 300 kW.** Bus bar kits are available on alternators with leads for connection to the generator set when circuit breakers are not ordered.

**350- 2500 kW.** A bus bar kit is provided when no circuit breaker is ordered. Bus bars are also available in combination with circuit breakers or other bus bars on the opposite side of the junction box. On medium voltage (3.3 kV and above) units, a bus bar kit is standard (not applicable to KD models).

### Field Connection Barrier

Provides installer wiring isolation from factory connections.

### Ground Fault Annunciation

A relay contact for customer connection indicates a ground fault condition and is part of a ground fault alarm.

### Lockout Device (padlock attachment)

This field-installable handle padlock attachment is available for manually operated circuit breakers. The attachment can accommodate three padlocks and will lock the circuit breaker in the OFF position only.

### Lugs

Various lug sizes are available to accommodate multiple cable sizes for connection to the neutral or bus bar.

### Overcurrent Trip Switch

The overcurrent trip switch indicates that the circuit breaker has tripped due to overload, ground fault, or short circuit and returns to the deenergized state when the circuit breaker is reset.

### Shunt Trip, 12 VDC or 24 VDC

A shunt trip option provides a solenoid within the circuit breaker case that, when momentarily energized from a remote source, activates the trip mechanism. This feature allows the circuit breaker to be tripped by customer-selected faults such as alternator overload or overspeed. The circuit breaker must be reset locally after being tripped. Tripping has priority over manual or motor operator closing.

### Shunt Trip Wiring

Connects the shunt trip to the generator set controller. (standard on KD models with the APM802 controller)

### Undervoltage Trip, 12 VDC or 24 VDC

The undervoltage trips the circuit breaker when the control voltage drops below the preset threshold of 35%- 70% of the rated voltage.

## 15- 300\* kW Line Circuit Breaker Specifications

\* Includes models 300REOZJ and 300REZXC. For other 300 kW models, see the 300- 2250 kW section.

### 100% Rating Circuit Breaker

Alt. Model	Ampere Range	Trip Type	C. B. Frame Size		
4D/4E	15- 150	Thermal magnetic	HD		
		Electronic LI			
		Electronic LSI			
	60- 150	Electronic LSI		HG	
		Electronic LSI			
		Electronic LSI			
4P/4PX 4Q/4QX	15- 150	Thermal magnetic	HD		
		Electronic LI			
		Electronic LSI			
	60- 150	Electronic LSI		HG	
		Electronic LSI			
		Electronic LSI			
	175- 250	Thermal magnetic	JD		
		Electronic LI			
		Electronic LSI			
	250	Electronic LSI	JD		
				Electronic LSI	
				Electronic LSI	
		250	Electronic LSI	JG	
					Electronic LSI
					Electronic LSI
	400	Electronic LSI	LG		
				Electronic LSI	
				Electronic LSI	
4RX 4S/4SX 4TX 4V 4UA 4M6226	15- 150	Thermal magnetic	HD		
		Electronic LI			
		Electronic LSI			
	60- 150	Electronic LSI		HG	
		Electronic LSI			
		Electronic LSI			
	175- 250	Thermal magnetic	JD		
		Electronic LI			
		Electronic LSI			
	250	Electronic LSI	JG		
				Electronic LSI	
				Electronic LSI	
		400	Electronic LSI	LG	
					Electronic LSI
					Electronic LSI
	600- 800	Electronic LSI	PG		
				Electronic LSI	
				Electronic LSI	
4UA 4M6226	1000- 1200	Electronic LSI	PG		
		Electronic LSI			
	1200	Electronic LSI	PJ		
		Electronic LSI			

### 100% Rating Electrically Operated Breakers

For use as paralleling breakers with the Decision-Maker® 6000 Controller/DPS System or APM603 controller.

Generator-Mounted P-Frame, 24VDC Electrically Operated			
Alt. Model	Amps	Trip Unit	Frame
4RX 4S/4SX 4TX 4V	250	3.0 LI	PJ
	400	5.0 LSI	PJ
	600	3.0 LI	PL
	800	5.0 LSI	PL
4UA 4M6226	250	3.0 LI	PJ
	400	5.0 LSI	PJ
	600	3.0 LI	PL
	800	5.0 LSI	PL
	1000	3.0 LI	PL
	1200	5.0 LSI	PL

All circuit breakers listed in this table include line side bus and load side lugs, 24VDC motor operators, 2 type C auxiliary contacts, and 1 type C SDE overcurrent switch contact. No second breakers are allowed in combination with these breakers.

### Interrupting Ratings

Circuit Breaker Frame Size	240 Volt, kA	480 Volt, kA	600 Volt, kA
HD	25	18	14
HG	65	35	18
HJ	100	65	25
JD	25	18	14
JG	65	35	18
JJ	100	65	25
LA	42	30	22
<b>LG</b>			
MG	<b>65</b>	<b>35</b>	<b>18</b>
PG	65	35	18
PJ	100	65	25
PL	125	100	25

### Circuit Breaker Lugs Per Phase (Al/Cu)

Frame Size	Ampere Range	Wire Range
E (480 V max.)	30- 100	Up to two wire terminals fitting 10-32 or 1/4-20 stud
H	15- 150	One #14 to 3/0
J	175	One 1/0 to 4/0
	200- 250	One 3/0 to 350 kcmil
LA	300- 400	One #1 to 600 kcmil or Two #1 to 250 kcmil
<b>LG</b>	<b>400- 600</b>	<b>Two 2/0 to 500 kcmil AL/CU</b>
M	800	Three 3/0 to 500 kcmil
P	600-800	Three 3/0 to 500 kcmil
	1000-1200	Four 3/0 to 500 kcmil
Mechanical Load Lugs Included with H, J, and LG LSI Neutrals		
H	60- 150	One #14 to 3/0 AL/CU
J	250	One 3/0 to 350 kcmil AL/CU
LG	400- 600	Two 4/0 to 500 kcmil AL/CU

## 15- 300\* kW Line Circuit Breaker Applications

\* Includes models 300REOZJ and 300REZXC. For other 300 kW models, see the 300- 2250 kW section.

### Single Circuit Breaker Installations

A generator set with a single circuit breaker installed typically feeds a single transfer switch and then a distribution panel. This allows protection of the entire system.

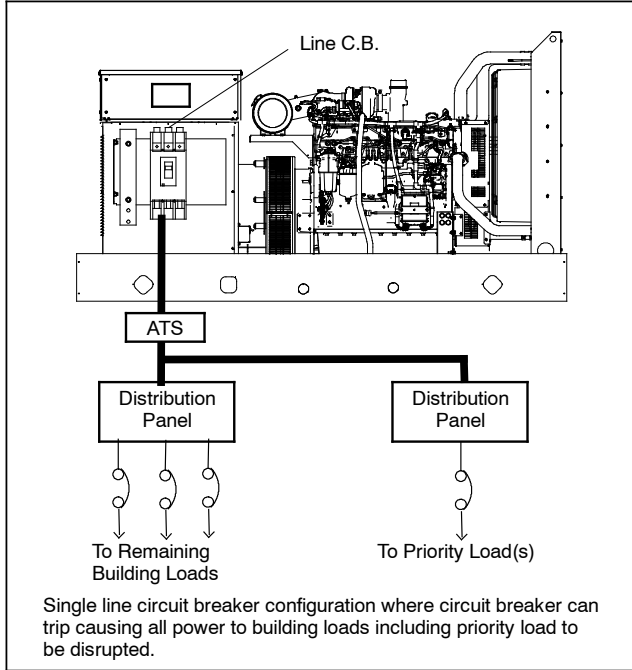

### Multiple Circuit Breaker Installations

A generator set with dual circuit breakers installed is used to separate critical loads. Typically, one circuit breaker will feed a main transfer switch with noncritical loads and the other circuit breaker will feed a second transfer switch that feeds critical or priority loads. Multiple circuit breakers allow circuit protection for special applications.

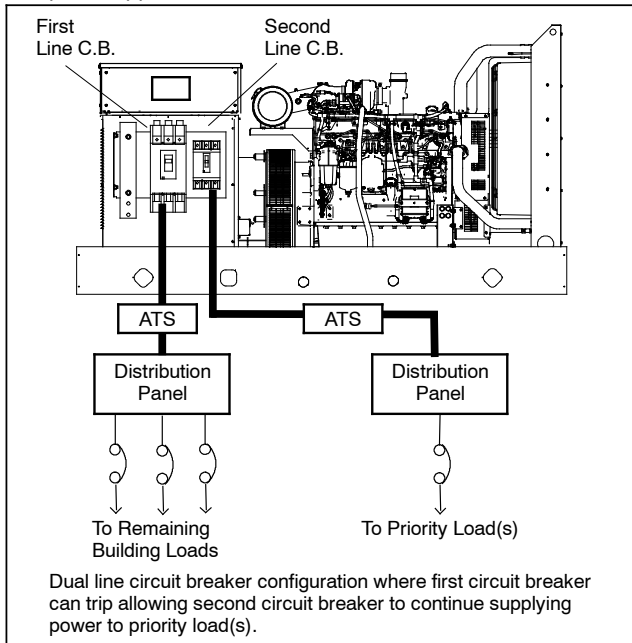

### Circuit Breaker Combinations

Alternator Model	First C. B. Frame	Second C. B. Frame	Third C. B. Frame	Trip Type
ALL except 4D/4E	H	—	—	All
	J	—	—	
	LA	—	—	
	LG	—	—	
4D/4E	H	—	—	Standard or LSIG
	H	H	—	No LSIG
4P/4PX 4Q/4QX	H	H or J	—	No LSIG
	J		—	
	LA	—		
	LG	H, J or LG	—	
4RX 4S/4SX 4TX 4V	M	—	—	All
	P	—	—	All
	H or J	H or J	—	No LSIG
	LA	H, J, or LA	—	
	LG	H, J, LA, or LG	—	
	M		—	
	P	—	—	
H or J	H or J	H or J		
4UA 4M6226	M or P	—	—	All
	H or J	H or J	—	All
	LA	H, J, or LA	—	
	LG	H, J, LA, or LG	—	
	M or P	H, J, LA, or LG	—	
	P	P	—	
	H or J	H or J	H or J	
	LA	H or J	H or J	
		LA	H, J, or LA	
	LG	H or J	H or J	
LA		H, J, or LA		
M or P	LA	H, J, or LA		
	LG	H, J, or LG		



# PowerPact™ H-, J-, and L-Frame Circuit Breakers Trip Curves

Figure 96: Micrologic 3.3S and 3.3S-W Electronic Trip Unit Long Time/Short Time Trip Curve

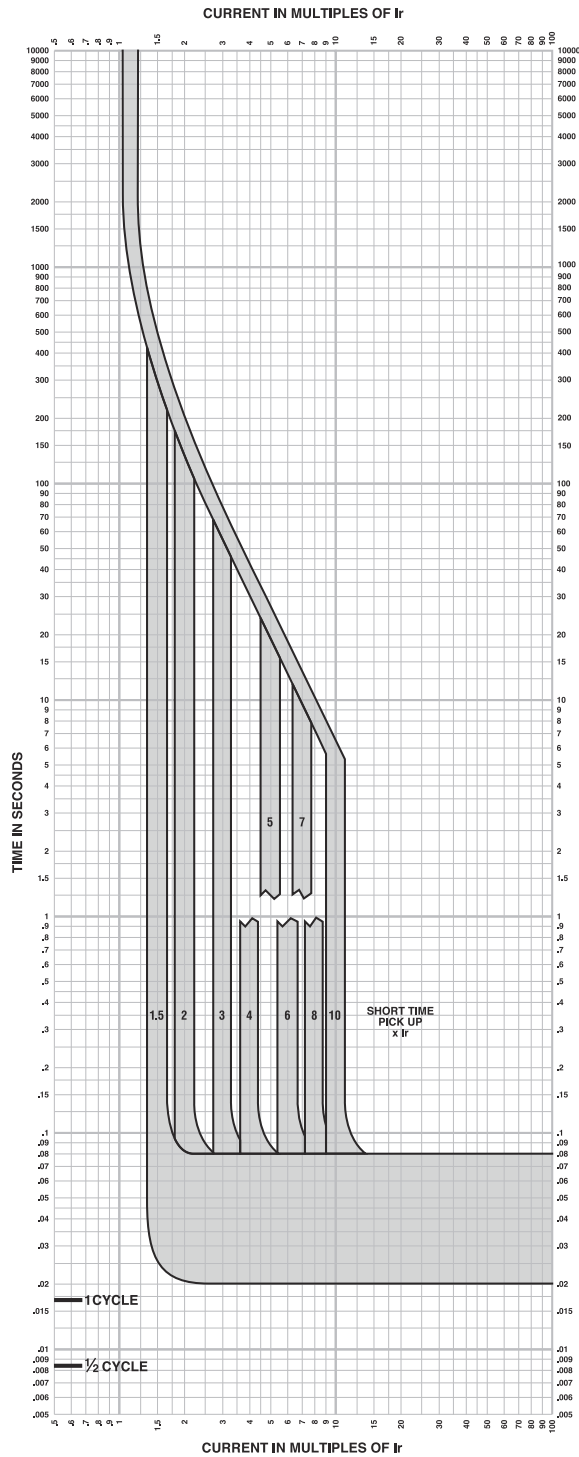

## MICROLOGIC™ ELECTRONIC TRIP UNITS Micrologic™ 3.3S and 3.3S-W Long Time/Short Time Trip Curve 250A, 400A L-Frame

The time-current curve information is to be used for application and coordination purposes only.

### Notes:

1. There is a thermal-imaging effect that can act to shorten the long-time delay. The thermal imaging effect comes into play if a current above the long-time delay pickup value exists for a time and then is cleared by the tripping of a downstream device or the circuit breaker itself. A subsequent overload will cause the circuit breaker to trip in a shorter time than normal. The amount of time delay reduction is inverse to the amount of time that has elapsed since the previous overload. Approximately 20 minutes is required between overloads to completely reset thermal-imaging.
2. Total clearing times shown include the response times of the trip unit, the circuit breaker opening, and the extinction of the current.

Curves apply from -35°C to +70°C (-31°F to +158°F) ambient temperature.



Typical Overall Dimensions

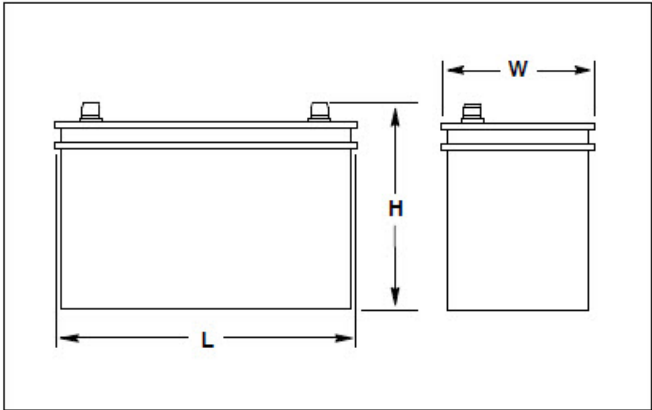

Standard Features

- Kohler Co. selects batteries to meet the engine manufacturer's specifications and to comply with NFPA requirements for engine-cranking cycles.
- Heavy-duty starting batteries are the most cost-effective means of engine cranking and provide excellent reliability in generator set applications.
- Tough polypropylene cases protect against life-shortening vibration and impact damage.
- Batteries are rated according to SAE standard J-537.
- All batteries are 12-volts. Kits that contain two or four batteries are available for 24-volt systems and/or systems with redundant starters.
- Wet- and dry-charged batteries have lead-calcium or lead-antimony plates and use sulfuric acid electrolyte. Removable cell covers allow checking of electrolyte specific gravity.
- Absorbant glass mat (AGM) batteries are sealed and maintenance free.
- Batteries are for applications below and above 0°C (32°F).

Charge Type*	Battery Part Number	Battery Qty. per Size	BCI Group Size	Battery SAE Dimension, mm (in.)			Cold Cranking Amps at 18°C (0°F) Min.	Reserve Capacity Minutes at 27° (80°F) Min.	Battery Post Layout and Style
				L	W	H			
Wet	256984	1	24	273.0 (10.8)	173.0 (6.8)	228.6 (9.0)	650	130	D/1

Battery Specifications

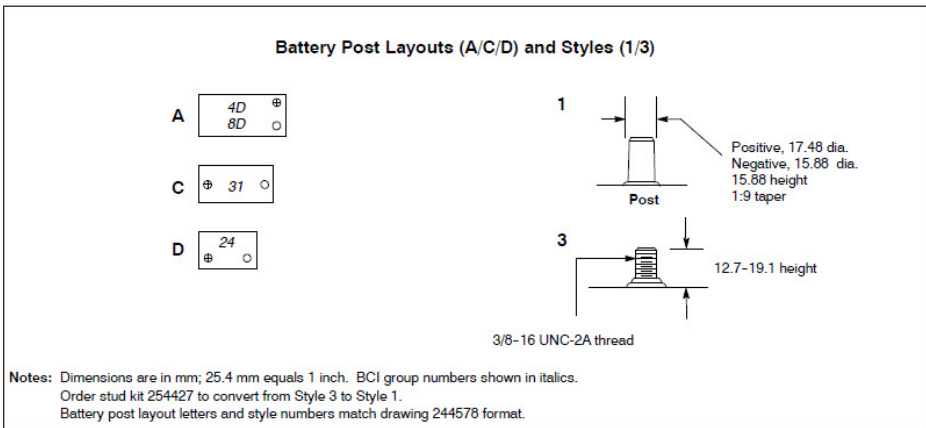

## Industrial Generator Set Accessories

# KOHLER Power Systems

**12 Volt (24 Volt\*), 6 Amp  
Float/Equalize Battery Charger**

**9001**  
KOHLER  
POWER SYSTEMS  
NATIONALLY REGISTERED



### Standard Features

- 12 VDC output. \* Use two battery chargers for 24-volt electrical systems
- Automatic 3-stage float/equalize battery charger
- Charges both lead-acid and gel-cell type batteries
- Indicator lamps: red and green LEDs indicate bulk charge, absorption, and float charge stages
- Durable potted assembly for full waterproofing and shockproofing
- Reverse-polarity protection
- Short-circuit protection
- UL 1236 listed
- UL 2200 compliant
- UL 991 compliant for vibration and shock
- UL listed to Canadian safety standards
- UL rated inline fuse
- FCC Class B-compliant for EMI/RFI (Date code 8/26/04 or later)
- One-year warranty
- Easy installation:
  - Integral mounting flanges
  - Ring terminals for battery connection
  - Standard US style 3-prong AC plug

### Specifications

Input Voltage	90–135 VAC
Input Frequency	50/60 Hz
DC Output:	
Bulk	11.8–14.0 VDC @ 5.0–6.0 amps
Absorption	14.0–14.5 VDC @ 1.5–5.0 amps
Float	13.3–14.5 VDC @ 0.1–1.5 amps
Steady Full-Load Output Current	6 amps
Current Limit	7 amps
Output Power Limit	70 +2/-5 watts
Line Regulation Across Input Voltage Range	1%
Isolation, Input to Output	2500 V
Dimensions (L x W x D)	164 x 87 x 53 mm (6.4 x 3.5 x 2.1 in)
Weight	1.6 kg (3.5 lb.)
Temperature Range, Operating and Storage	-40° to 70°C (-40° to 158° F)
Humidity	0 to 100% (condensing)

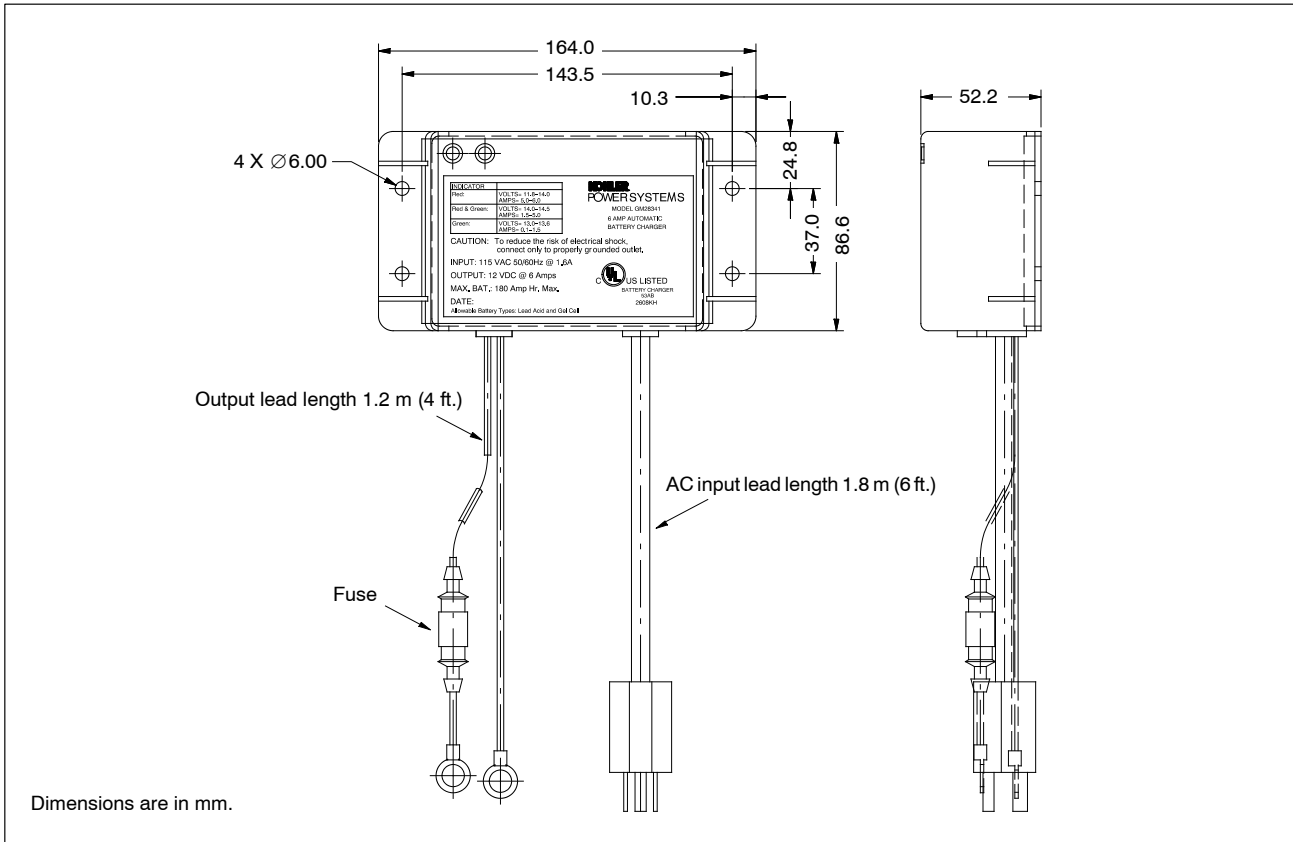

### Battery Connections

- Lead Length 1.2 m (4 ft.)
- Battery Connections 9.5 mm (3/8 in.) ring terminals

### AC Power Connections

- Lead Length 1.8 m (6 ft.)
- Connection Standard US style 3-prong AC plug

### Charging Curves

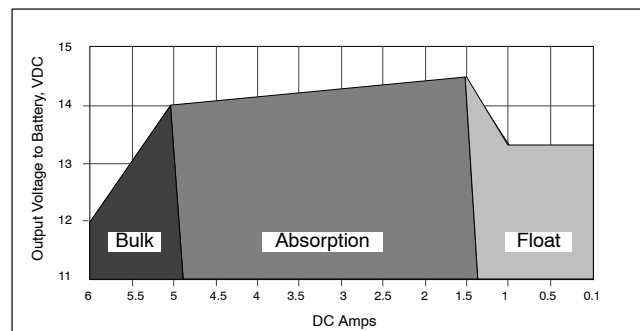

### DISTRIBUTED BY:

Availability is subject to change without notice. Kohler Co. reserves the right to change the design or specifications without notice and without any obligation or liability whatsoever. Contact your local Kohler® generator set distributor for availability.

© 2003, 2004, 2011, 2014, 2016 by Kohler Co. All rights reserved.

**ISO 9001**  
**KOHLER**  
 POWER SYSTEMS  
 NATIONALLY REGISTERED

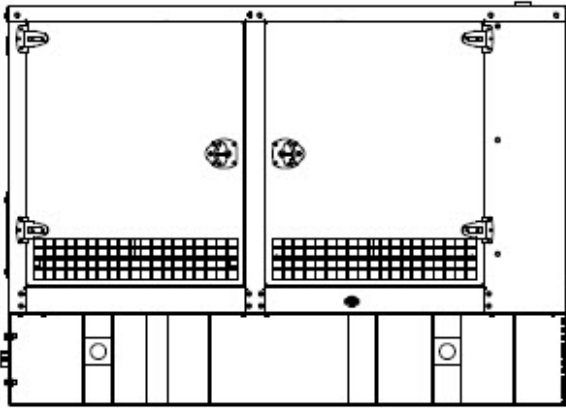

Enclosure with Standard Subbase Fuel Tank

### Sound Enclosure Standard Features

- Internal-mounted critical silencer and flexible exhaust connector.
- Lift base-mounted or tank mounted steel construction with hinged doors.
- Fade-, scratch-, and corrosion-resistant Kohler® Power Armor automotive-grade textured finish.
- Power Armor surpasses 3,000-hour salt spray corrosion tests per ASTM B- 1117
- Enclosure has four access doors which allow for easy maintenance.
- Lockable, flush-mounted door latches.
- Vertical air inlet and outlet discharge to redirect air and reduce noise.
- Acoustic insulation that meets UL 94 HF1 flammability classification and repels moisture adsorption.
- Sound-attenuated that uses up to 51 mm (2 in.) of acoustic insulation.
- Steel sound enclosure is designed to 150 mph (241 kph) wind load rating.

### Subbase Fuel Tank Features

- The fuel tank has a Power Armor Plus textured epoxy-based rubberized coating.
- The above-ground rectangular secondary containment tank mounts directly to the generator set, below the generator set skid (subbase).
- Both the inner and outer tanks have emergency relief vents.
- Flexible fuel lines are provided with subbase fuel tank selection.
- The secondary containment generator set base tank meets UL 142 tank requirements. The inner (primary) tank is sealed inside the outer (secondary) tank. The outer tank contains the fuel if the inner tank leaks or ruptures.

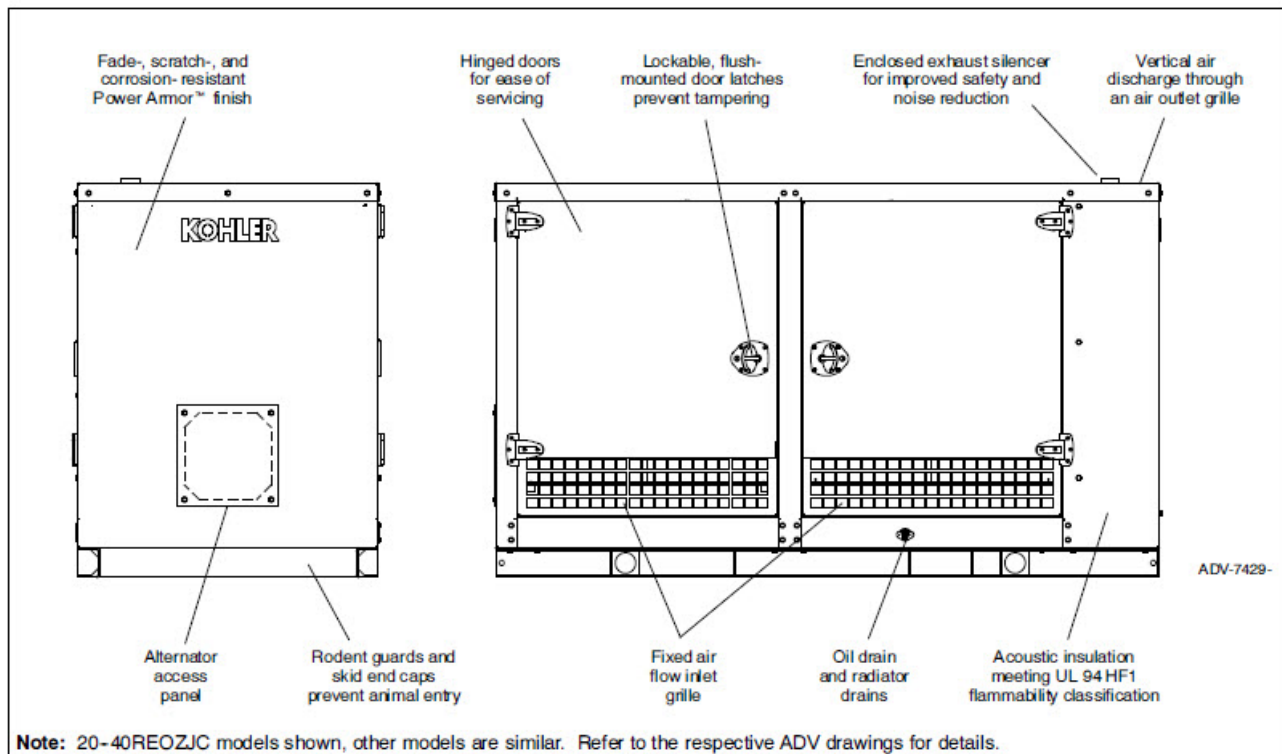

## Sound Enclosure Features

- Available in steel (14 gauge) formed panel, solid construction. Preassembled package offering corrosion resistant, dent resilient structure mounting directly to lift base or fuel tank.
- Power Armor automotive-grade finish resulting in advanced corrosion and abrasion protection as well as enhanced edge coverage and color retention.
- Internal exhaust silencer offering maximum component life and operator safety.
- Interchangeable modular panel construction. Allows complete serviceability or replacement without compromising enclosure design.
- Cooling/combustion air intake with a horizontal air inlet. Sized for maximum cooling airflow.
- Service access. Multi-personnel doors for easy access to generator set control and servicing of the fuel fill, fuel gauge, oil fill and battery.
- Cooling air discharge. Weather protective design featuring vertical air discharge. Redirects cooling air up and above the enclosure to reduce ambient noise.
- Attenuated design. Acoustic insulation UL 94 HF1 listed for flame resistance offering up to 51 mm (2 in.) mechanically restrained acoustic insulation.
- Cooling air discharge. The sound enclosures include acoustic insulation with urethane film.
- Note: Installing an additional length of exhaust tail pipe may increase backpressure levels. Please refer to the generator set spec sheet for the maximum backpressure value.

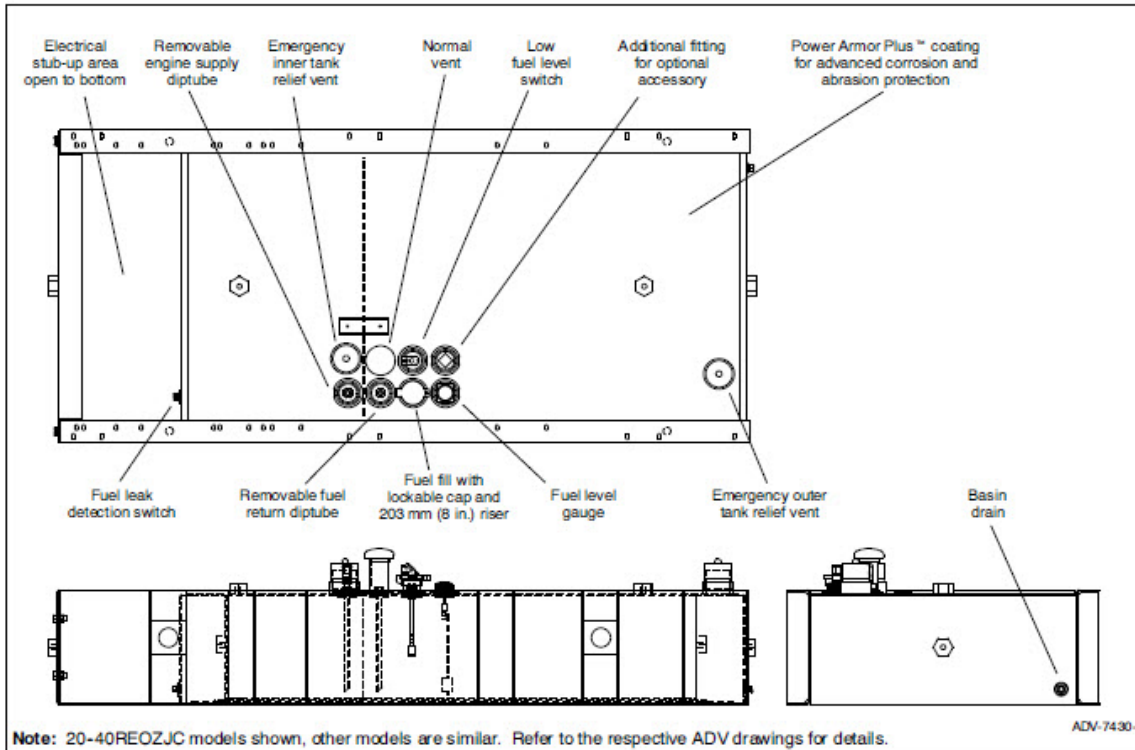

- Extended operation. Usable tank capacities offers full load standby operation of up to 72 hours.
- Power Armor Plus textured epoxy-based rubberized coating that creates an ultra-thick barrier between the tank and harsh environmental conditions like humidity, saltwater, and extreme temperatures, and provides advanced corrosion and abrasion protection.
- UL listed. Secondary containment generator set base tank meeting UL 142 tank requirements.
- NFPA compliant. Designed to comply with the installation standards of NFPA 30 and NFPA 37.
- Integral external lift lugs. Enables crane with spreader-bar lifting of the complete package (empty tank, mounted generator set, and enclosure) to ensure safety.
- Emergency pressure relief vents. Meets UL requirements; ensures adequate venting of inner and outer tank under extreme pressure and/or emergency conditions.
- Normal vent with cap. Vent is raised above lockable fuel fill.
- Low fuel level switch. Annunciates a 50% low fuel level condition at generator set control.
- Leak detection switch. Annunciates a contained primary tank fuel leak condition at generator set control.
- Electrical stub-up.

Fuel Tank Capacity, L (gal.)	Est. Fuel Supply Hours at 60 Hz with Full Load	Enclosure and Fuel Tank Length, mm (in.)	Enclosure and Fuel Tank Width, mm (in.)	Enclosure and Fuel Tank Weight, kg (lb.)	Enclosure and Fuel Tank Height, mm (in.)	Fuel Tank Height (H), mm (in.)	Sound Pressure Level, dB(A)
791 (209)	24/25	2821 (111.1)	1156 (45.5)	1875 (4134)	2081 (81.9)	508 (20)	69

Note: Data in table is for reference only, refer to the respective ADV drawings for details.

Note: Refer to TIB-114 for generator set sound data.

Max. weight includes the generator set (wet), enclosure, silencer, and tank (no fuel). The generator set weight represents using the largest alternator option. The enclosure weight is with acoustic insulation added.

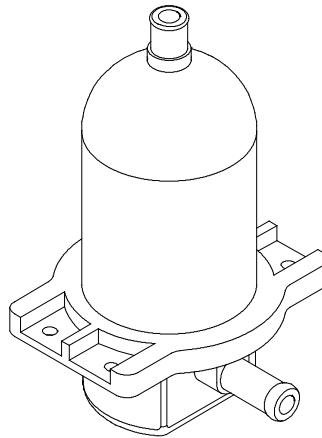
**Engine Block Heater Kits**

Block Heater Kit, typical

**Applicable Models**

- KG40- KG125
- KG150- KG200
- KG150R
- 25- 45REZG
- 25- 60REZGB
- 50REZGC/125REZGC/150REZGC
- 50- 60REOZJD
- 50REOZJE
- 80REZGD/100REZGD
- 80RZGD/100RZGD
- **80- 200REOZJF**
- 80- 150REOZJG4
- 125RZGC/150RZGC
- 125REOZJG/180REOZJG

**Standard Features**

- UL- C/US listed
- CE compliant
- Controls for automatic operation
- Compact design
- Easy to install

**Description**

The engine block heater kit heats the engine coolant in cold ambient, warming the cylinders, oil, and charge air circuit which all help to give a faster starting time. The engine block heater uses thermosiphon action to circulate warm coolant into the engine and supplies constant heating to the engine. The engine block heater kit helps to extend element life and gives a significant reduction in electrical consumption.

The engine block heater kit is recommended for ambient temperatures below 10°C (50°F).

The engine block heater kits are available in 120 V, 240 V, and 277 V versions.



## Block Heater Specifications

Heating Fluid	Water, Coolant Mix (50% Glycol/50% Water)
Max. Pressure	90 psi (620 kPa)
Heating Element Material	Incoloy 800
Inlet/Outlet Plumbing	0.625 in. hose barb
System Ingress	IP41
Power Connection	NEMA Plug and EURO Plug
Power Chord Length	48 in. (1219 mm)

## Specifications

Block Heater Kit Number	Component	Watts	Voltage	Phase	Thermostat Temperature	
					ON	OFF
GM58098- KA1	358311	1000	120	1	27°C (80°F)	38°C (100°F)
GM75536- KA1	326228	1500	120	1	49°C (120°F)	60°C (140°F)
GM75555- KA5	GM75552	1800	120	1	27°C (80°F)	38°C (100°F)
GM75555- KA6	GM75553	2000	240	1		
GM75556- KA1	352945	1500	120	1		
GM75557- KA1	352945	1500	120	1		
GM75564- KA1	358311	1000	120	1		
GM75565- KA1	352945	1500	120	1		
GM77944- KA1	352945	1500	120	1		
GM77944- KA2	352946	1500	240	1		
GM85060- KA1	GM75552	1800	120	1		
GM85060- KA2	GM75553	2000	240	1		
GM89427- KA2	GM75552	1800	120	1		
GM91708- KA1	352945	1500	120	1		
GM94248- KA1	352945	1500	120	1		
GM104799- KA1	352945	1500	120	1		
GM105165- KA1	352945	1500	120	1		
GM105165- KA2	352946	1500	240	1		
GM105409- KA1	352945	1500	120	1		
GM105409- KA2	352946	1500	240	1		

## Dimensions and Weights

Overall Size, H x W, mm (in): 199 x 122 (7.8 x 4.8)  
Weight, kg (lb): 0.77 (1.7)

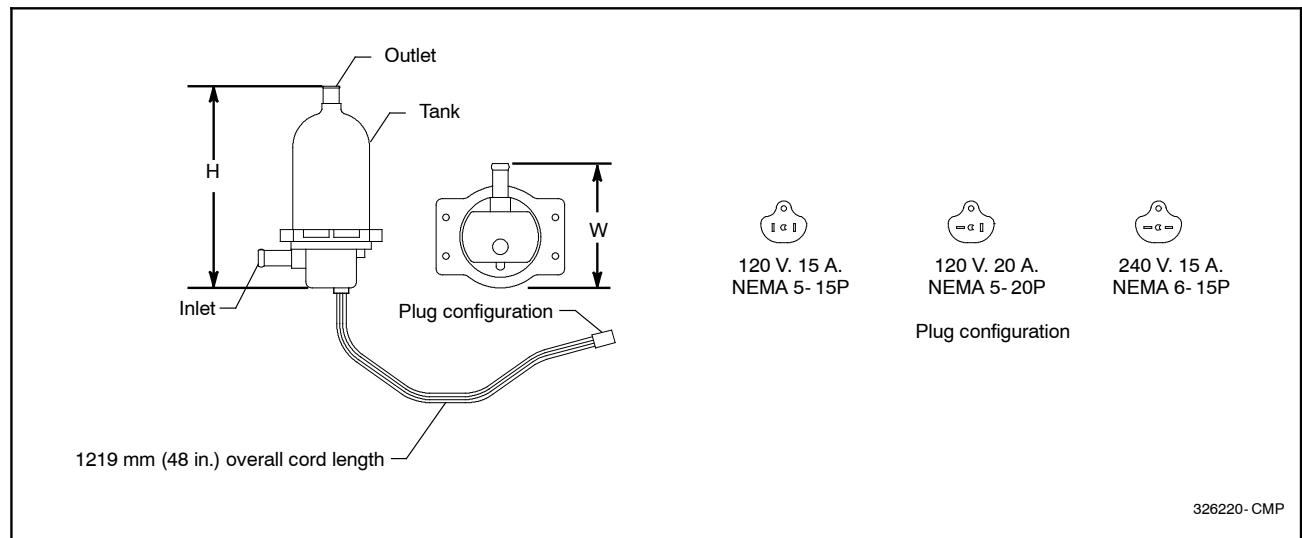



**Integral Voltage Regulator with Kohler® APM402/ Decision-Maker® 3000 and Menu-Driven Selections (15-1000 kW Generator Set Models)**

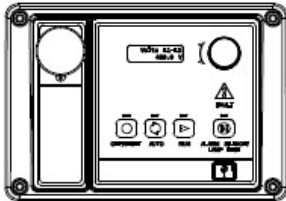

**APM402 and Decision-Maker® 3000 Controller with Integral Voltage Regulator**

The voltage regulator is integral to the controller and uses patented hybrid voltage regulator design providing ±0.5% no-load to full-load regulation using root-mean-square (RMS) voltage sensing. The voltage regulator features three-phase sensing and is available for 12- or 24-volt engine electrical systems.

**Voltage Regulators**

The following information provides general features, specifications, and functions of available voltage regulators.

This information generally applies to a single generator set and multiple generator sets with paralleling applications. Refer to the respective generator set specification sheet and see your authorized distributor for information regarding specific voltage regulator applications and availability.

**Integral Voltage Regulators with APM402/Decision-Maker® 3000 Controllers**

Calibration	Digital Display	Range Settings	Default Selection
Voltage Adjustment	Volt Adj	±10% of System Voltage	System Voltage
Underfrequency Unload or Frequency Setpoint	Frequency Setpoint	42 to 62 Hz	2.5 Hz Below Nominal Frequency
Underfrequency Unload Scope	Slope	0-10% of System Voltage (Volts per Cycle)	5% of System Voltage



Specification/Feature	Integral with APM402/Decision-Maker® 3000
Generator Set Availability	15-1000 kW
Type	Patented Hybrid Design
Status and Shutdown Indicators	LEDs and Text LCD Display
Operating Temperature	-40°C to 70°C (-40°F to 158°F)
Storage Temperature	-40°C to 85°C (-40°F to 185°F)
Humidity	5-95% Non-Condensing
Circuit Protection	Solid-State, Redundant Software and Fuses
Sensing, Nominal	100-240 Volts (L-L), 50-60 Hz
Sensing Mode	RMS, Single- or 3-Phase
Input Requirements	8-36 VDC
Continuous Output	5 VDC @ 100mA max. 5.0 ADC with GM88453 Activator Board
Maximum Output	5 VDC @ 100mA max. 5.0 ADC with GM88453 Activator Board
Transition Frequency	42.0-62.0Hz
Exciter Field Resistance	4-30 Ohms with GM88453 Activator Board
No-Load to Full-Load Voltage Regulation	±0.5%
Thermal Drift	<0.5% (-40°C to 70°C) [-40°F to 158°F] Range
Response Time	Less than 5µS
System Voltage Adjust.	±10%
Voltage Adjustment	Controller Menu Knob
Remote Voltage Adjustment	not available
Paralleling Capability	not available
VAR/PF Control Input	not available

### Integral Voltage Regulator with APM402/Decision-Maker® 3000 Controller

- The APM402/Decision-Maker® 3000 digital display and pushbutton/rotary dial provide access to data. A two-line LCD display provides complete and concise information. A two-line vacuum fluorescent display provides complete and concise information.
- The Decision-Maker® 3000 graphical display and pushbutton/rotary dial provide access to data. A five-line, 35-characters per line LCD display provides complete and concise information include gain, ramp rate, reactive droop, VAR control (P, I, D gains) and PF control (P, I, D gains).
- The controllers provide ISO 8528-5, Class G3, compliance for transient response on some 20-300 kW generator set models. Both controllers support Modbus®.
- These controllers can control Fast Response™ II, Fast Response™ X, and wound field alternators using the GM88453 activator board.

#### Voltage Regulator Menu

- Voltage adjustment, ±10% of system voltage
- V/Hz cut-in, 42-62 Hz
- Underfrequency unload slope, 0-10% of system voltage

#### Jumpers

- L1-L2 volts
- L2-L3 volts (3-phase)
- L3-L1 volts (3-phase)
- L1-N volts
- L2-N volts
- L3-N volts (3-phase)

# KOHLER®

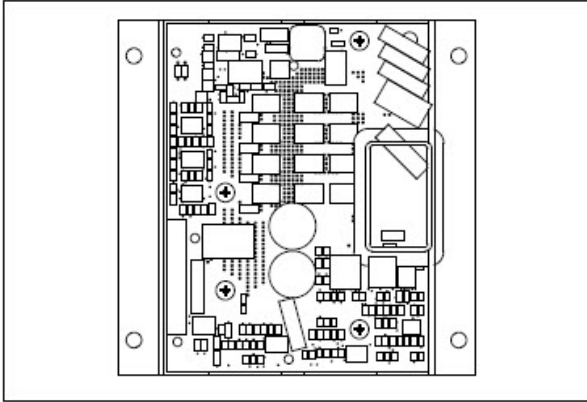

- Interfaces between the controller and alternator assembly using rotor field leads, auxiliary power windings, and optic board leads.
- Allows the Decision-Maker® controllers the ability to control a wound-field alternator using the same control signal as Fast Response™ alternator.
- Permits the generator set controller to control the current to the exciter field of a wound-field excited alternator.
- Contains two isolated relay driver outputs (RDO) rated at 250 mA. Provides RDO outputs indicating a field over-excitation condition and that the alternator is supplying voltage to the activator.

Modbus® is a registered trademark of Schneider Electric.

**KOHLER®**

# Alternator Data

**TECHNICAL INFORMATION BULLETIN**

**Alternator Data Sheet**

**Alternator Model: 4R9X**  
**Frequency: 60 Hz**  
**Speed: 1800 RPM**  
**Leads: 12 (6 Lead, 600 Volt)**

Voltage L-N/L-L	Phase	Power Factor	Connection	kW* (kVA)						
				Class B		Class F			Class H	
				80°C Continuous	90°C Lloyds	95°C ABS	105°C Continuous	130°C Standby	125°C Continuous	150°C Standby
139/240 277/480	3	0.8	Wye	84.0 (105.0)	88.5 (110.5)	90.5 (113.0)	95.0 (118.5)	103.0 (128.5)	101.5 (126.5)	109.5 (136.5)
127/220 254/440	3	0.8	Wye	83.0 (103.5)	87.5 (109.0)	89.5 (111.5)	93.5 (116.5)	101.5 (126.5)	100.0 (125.0)	108.0 (135.0)
120/208 240/416	3	0.8	Wye	82.0 (102.5)	86.0 (107.5)	88.0 (110.0)	92.0 (115.0)	100.5 (125.5)	98.5 (123.0)	106.5 (133.0)
110/190 220/380	3	0.8	Wye	74.5 (93.0)	78.0 (97.5)	80.0 (100.0)	84.5 (105.5)	91.5 (114.0)	89.5 (111.5)	96.5 (120.5)
120/240	3	0.8	Delta	82.0 (102.5)	86.0 (107.5)	88.0 (110.0)	92.0 (115.0)	100.5 (125.5)	98.5 (123.0)	106.5 (133.0)
120/240	1	1.0	Dogleg	64.5 (64.5)	67.5 (67.5)	68.5 (68.5)	71.0 (71.0)	77.5 (77.5)	76.5 (76.5)	82.5 (82.5)
347/600	3	0.8	Wye	83.5 (104.0)	88.0 (110.0)	90.0 (112.5)	94.5 (118.0)	102.5 (128.0)	101.0 (126.0)	109.0 (136.0)

\* All data tested in accordance with IEEE Standard 115. Kohler Co. reserves the right to change the design or specifications without notice and without any obligation or liability whatsoever.

**Submittal Data: 139/240 Volts, 0.8 PF, 1800 RPM, 60 Hz, 3 Phase, 130°C Rise**

	Symbol	PerUnit	Ohms		Symbol	Value
<b>Typical Cold Resistances</b>				<b>Typical Time Constants</b>		
Phase Resistance		0.036	0.016	Armature Short Circuit	T <sub>a</sub>	0.007 sec.
Rotor Resistance		16.96	7.585	Transient Short Circuit	T' <sub>d</sub>	0.065 sec.
<b>Typical Reactances</b>				Transient Open Circuit	T' <sub>do</sub>	0.748 sec.
Synchronous				<b>Typical Field Current</b>		
Direct	X <sub>d</sub>	2.969	1.328	Full Load	I <sub>fFL</sub>	21.6 amps
Quadrature	X <sub>q</sub>	1.523	0.681	No Load	I <sub>fNL</sub>	5.6 amps
Transient				<b>Typical Short Circuit Ratio</b>		0.337
Unsaturated	X' <sub>du</sub>	0.292	0.131	<b>Harmonic Distortion</b>		
Saturated	X' <sub>d</sub>	0.257	0.115	RMS Total Harmonic Distortion		3.20%
Subtransient				Max. Single Harmonic		5th
Direct	X'' <sub>d</sub>	0.123	0.055	Deviation Factor (No Load, L-L)		<5%
Quadrature	X'' <sub>q</sub>	0.114	0.051	Telephone Influence Factor		<50
Negative Sequence	X <sub>2</sub>	0.118	0.053	<b>Insulation Class</b>		
Zero Sequence	X <sub>0</sub>	0.011	0.005	per NEMA MG1-1.66		H
				<b>Phase Rotation</b>		ABC

**4R9X, 60 Hz, 139/240, 277/480 Volts, Wye  
TYPICAL ALTERNATOR EFFICIENCY\***

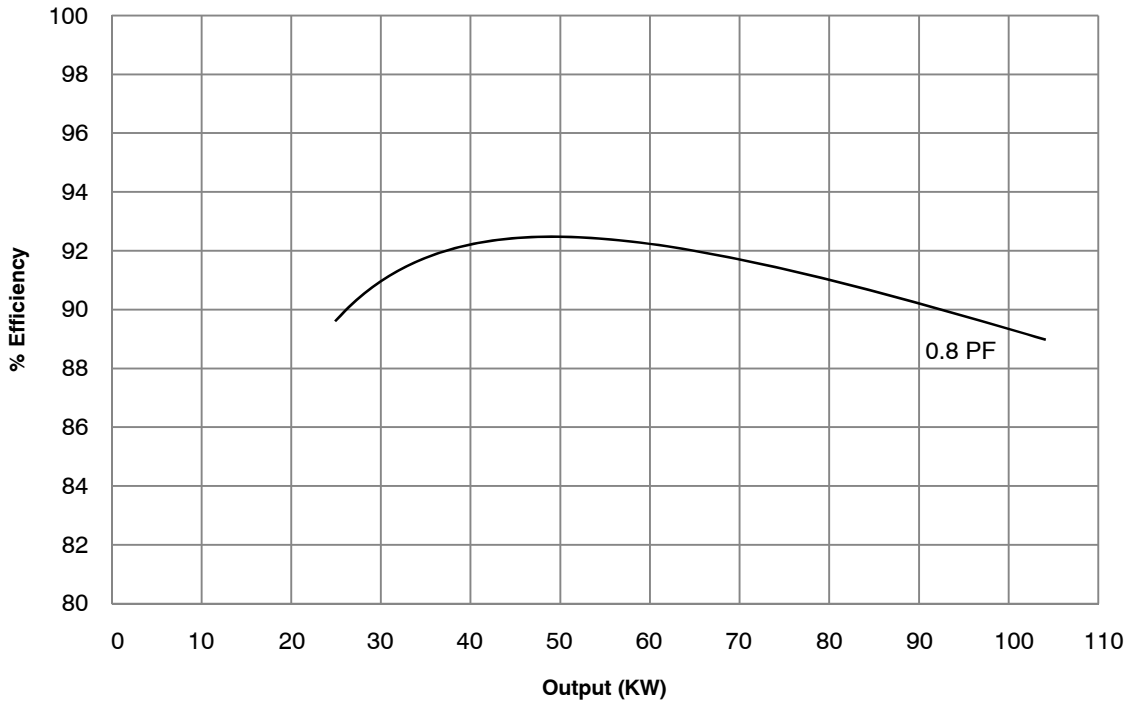

**4R9X, 60 Hz, 139/240, 277/480 Volts, Wye  
TYPICAL MOTOR STARTING CHARACTERISTICS\***

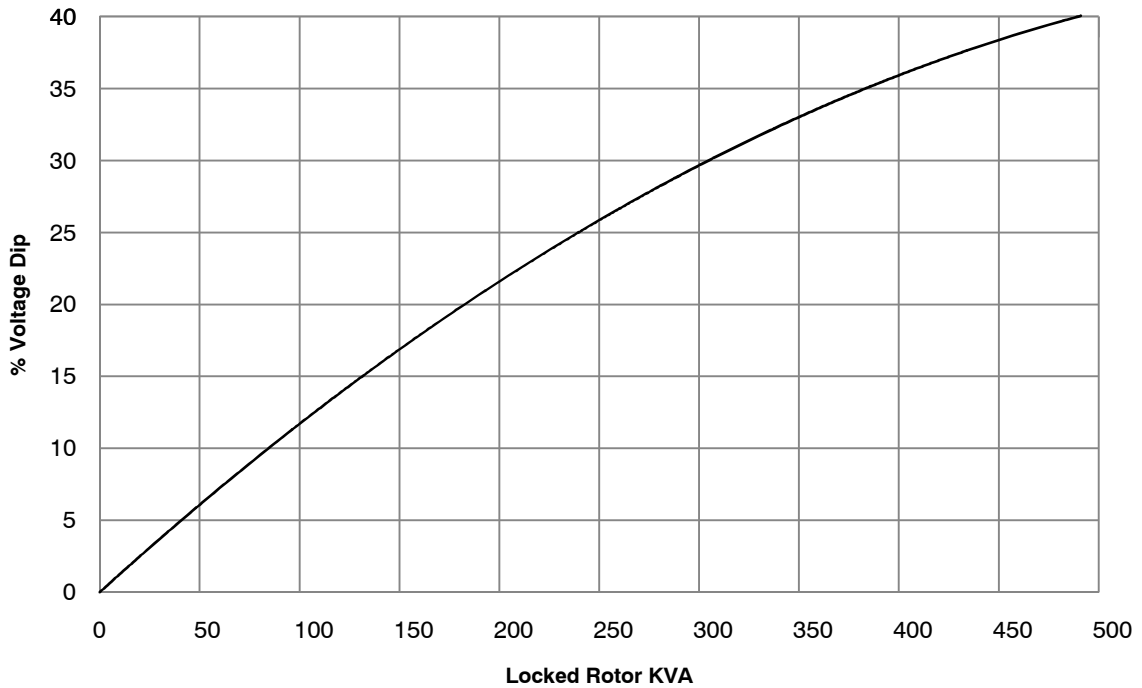

\* All data tested in accordance with IEEE Standard 115. Kohler Co. reserves the right to change the design or specifications without notice and without any obligation or liability whatsoever.



**4R9X, 60 Hz, Low Wye or Delta Connection  
SHORT CIRCUIT DECREMENT CURVE**

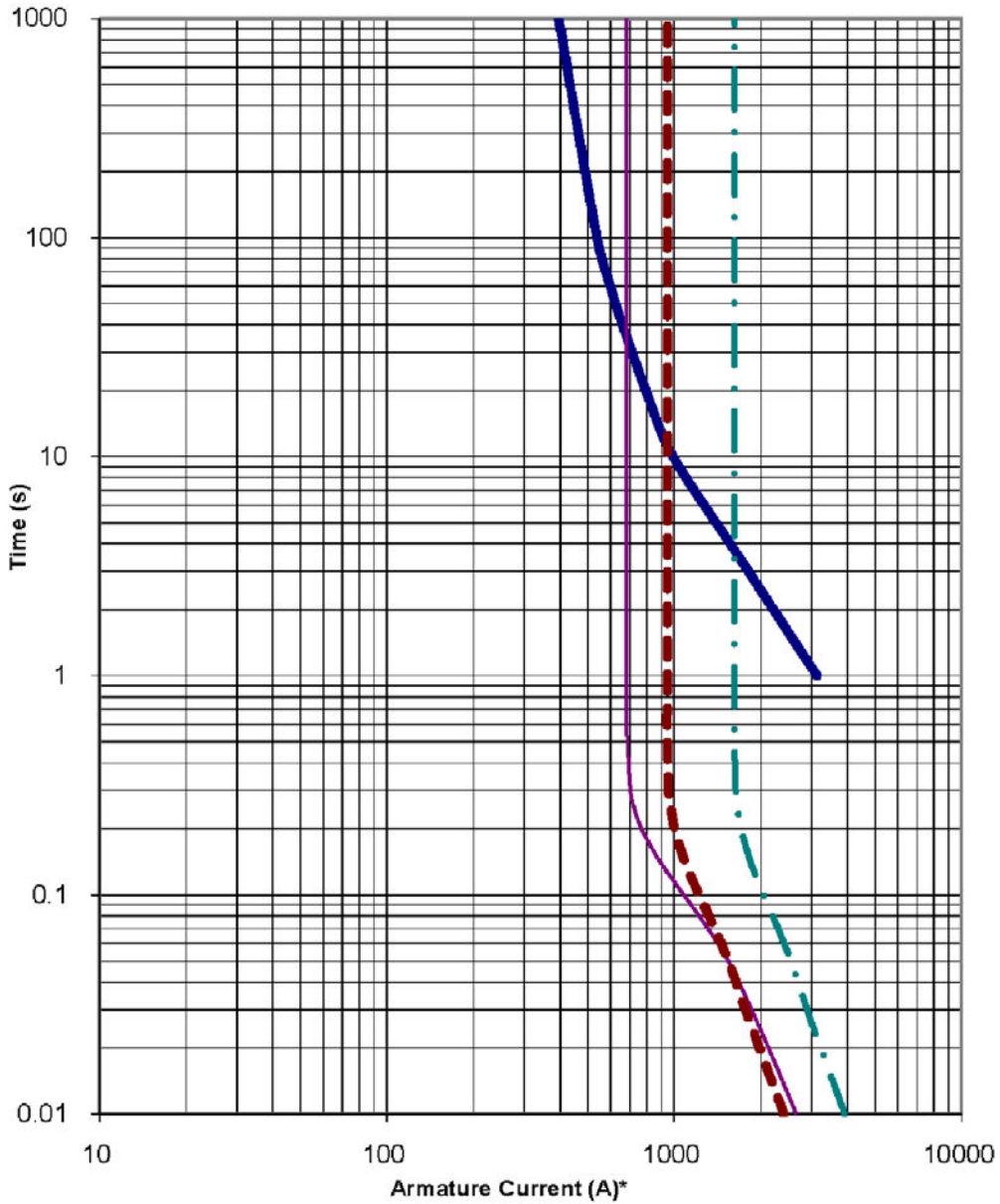

\*Instantaneous current (t=0) is asymmetric. Divide by 1.73 for symmetric.

**4R9X, 60 Hz, High Wye Connection  
SHORT CIRCUIT DECREMENT CURVE**

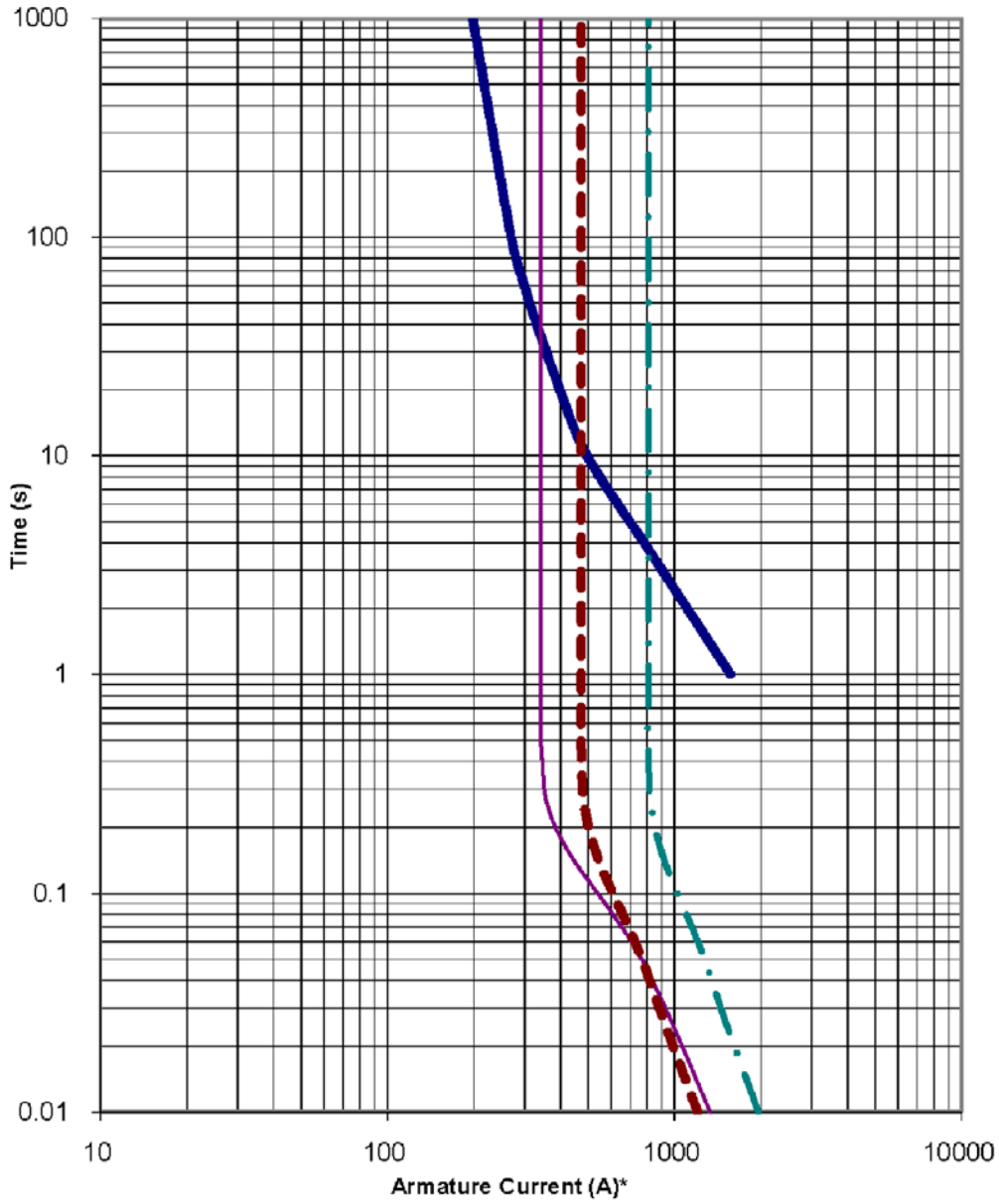

\*Instantaneous current (t=0) is asymmetric. Divide by 1.73 for symmetric.

**KOHLER®**

## Sound Data

**TECHNICAL INFORMATION BULLETIN**

**Generator Set Sound Data Sheet**

			Sound Pressure Data in dB(A)			
Generator Set Model	Hz	Load	Raw Exhaust	Open Unit, Isolated Exhaust	Weather Enclosure	Sound Enclosure
100REOZJF	60	100% Load	112.4	84.5	82.6	69.8
		No Load	100.1	80.9	79.0	68.3

Note: Sound pressure data is the logarithmic average of eight perimeter measurement points at a distance of 7 m (23 ft.), except Raw Exhaust data which is a single measurement point at 1 m (3.3 ft.) from the mouth of a straight pipe exhaust.

			Sound Pressure Levels, dB(A)									
Load	Distance, m (ft)	Enclosure	Measurement Clock Position	Octave Band Center Frequency (Hz)								Overall Level
				63	125	250	500	1000	2000	4000	8000	
100% Load	7 (23)	Sound	3:00	41.6	61.3	61.7	63.5	59.3	59.1	56.7	52.6	68.7
			1:30	45.4	59.1	63.1	66.1	63.0	60.4	60.7	54.8	70.6
			12:00-Engine	48.2	59.0	61.5	66.2	62.5	62.9	62.6	57.8	71.0
			10:30	48.9	60.3	63.5	66.3	62.6	60.9	60.6	56.5	70.9
			9:00	46.6	59.4	62.8	63.7	59.8	60.2	59.0	56.3	69.3
			7:30	44.7	59.2	63.6	63.0	60.9	60.6	60.6	58.2	69.8
			6:00-Alternator	49.9	56.7	59.6	64.1	60.0	60.2	58.8	55.0	68.6
			4:30	48.7	55.8	60.6	62.9	61.3	59.8	59.0	54.2	68.4
8-pos. log avg.			47.4	59.1	62.2	64.7	61.4	60.6	60.1	56.0	69.8	

			Sound Pressure Levels, dB(A)									
Load	Distance, m (ft)	Enclosure	Measurement Clock Position	Octave Band Center Frequency (Hz)								Overall Level
				63	125	250	500	1000	2000	4000	8000	
No Load	7 (23)	Sound	3:00	47.9	60.0	62.0	62.3	57.8	55.4	50.1	41.6	67.3
			1:30	51.0	58.7	63.3	65.7	62.2	57.0	55.9	43.5	69.7
			12:00-Engine	52.5	58.2	61.1	65.7	61.4	59.9	59.0	47.0	69.6
			10:30	51.9	60.0	63.9	65.4	61.5	56.2	55.0	44.4	69.7
			9:00	49.7	58.3	63.1	62.2	57.2	54.9	51.0	42.7	67.4
			7:30	42.6	60.4	65.1	61.0	58.4	55.8	50.1	42.5	68.3
			6:00-Alternator	46.8	54.3	58.4	62.8	57.5	53.8	50.2	38.5	65.9
			4:30	44.6	55.8	61.1	61.3	59.8	56.1	50.4	40.2	66.6
8-pos. log avg.			49.5	58.6	62.6	63.7	59.9	56.5	54.1	43.2	68.3	

**KOHLER®**

# Exhaust System Data

## TECHNICAL INFORMATION BULLETIN

### Enclosed Generator Set Exhaust System Data Sheet

Model	Enclosure Type	Consumed Back Pressure (in H2O)	Consumed Back Pressure (in Hg)	Back Pressure Limit(s) (in H2O)	Back Pressure Limit(s) (in Hg)	Flex Exhaust Tube(s)	Silencer	Drawing
100REOZJF	All Weather & Sound Enclosures & Snow Package Enclosure	28.7	2.1	30.0	2.2	GM66733	GM59117	ADV-7647

1. Total system exhaust back pressure is applicable to generator sets equipped with Kohler standard enclosure packages.
2. For generator sets with multiple exhaust outlets, total system exhaust back pressure value represents each outlet.
3. The total system back pressure should not exceed the manufacturer's recommended limit.
4. The total back pressure only includes exhaust components installed inside the Kohler enclosure. Customers must calculate any additional back pressure caused by piping, extensions, or components added after the silencer outlet. Refer to the installation manual for additional details.

**KOHLER®**

# Emissions Data



**UNITED STATES ENVIRONMENTAL PROTECTION AGENCY  
2022 MODEL YEAR  
CERTIFICATE OF CONFORMITY  
WITH THE CLEAN AIR ACT**

**OFFICE OF TRANSPORTATION  
AND AIR QUALITY  
ANN ARBOR, MICHIGAN 48105**

**Certificate Issued To:** Deere & Company  
(U.S. Manufacturer or Importer)  
**Certificate Number:** NJDXL04.5119-003

**Effective Date:**  
08/09/2021  
**Expiration Date:**  
12/31/2022

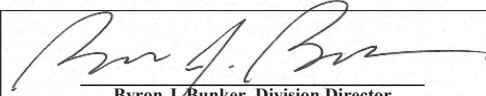
  
Byron J. Bunker, Division Director  
Compliance Division

**Issue Date:**  
08/09/2021  
**Revision Date:**  
N/A

**Model Year:** 2022  
**Manufacturer Type:** Original Engine Manufacturer  
**Engine Family:** NJDXL04.5119

**Mobile/Stationary Indicator:** Stationary  
**Emissions Power Category:** 75<=kW<130  
**Fuel Type:** Diesel  
**After Treatment Devices:** No After Treatment Devices Installed  
**Non-after Treatment Devices:** Electronic Control, Smoke Puff Limiter, Engine Design Modification, Non-standard Non-After Treatment Device Installed

Pursuant to Section 111 and Section 213 of the Clean Air Act (42 U.S.C. sections 7411 and 7547) and 40 CFR Part 60, and subject to the terms and conditions prescribed in those provisions, this certificate of conformity is hereby issued with respect to the test engines which have been found to conform to applicable requirements and which represent the following engines, by engine family, more fully described in the documentation required by 40 CFR Part 60 and produced in the stated model year.

This certificate of conformity covers only those new compression-ignition engines which conform in all material respects to the design specifications that applied to those engines described in the documentation required by 40 CFR Part 60 and which are produced during the model year stated on this certificate of the said manufacturer, as defined in 40 CFR Part 60.

It is a term of this certificate that the manufacturer shall consent to all inspections described in 40 CFR 1068 and authorized in a warrant or court order. Failure to comply with the requirements of such a warrant or court order may lead to revocation or suspension of this certificate for reasons specified in 40 CFR Part 60. It is also a term of this certificate that this certificate may be revoked or suspended or rendered void *ab initio* for other reasons specified in 40 CFR Part 60.

This certificate does not cover engines sold, offered for sale, or introduced, or delivered for introduction, into commerce in the U.S. prior to the effective date of the certificate.

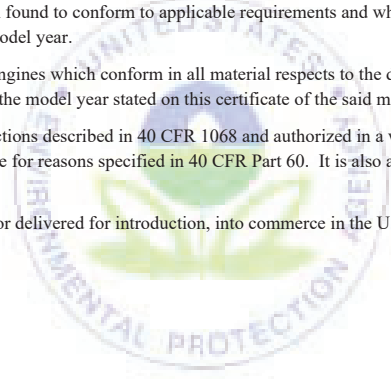



**KOHLER®**

# Dimensional Drawings

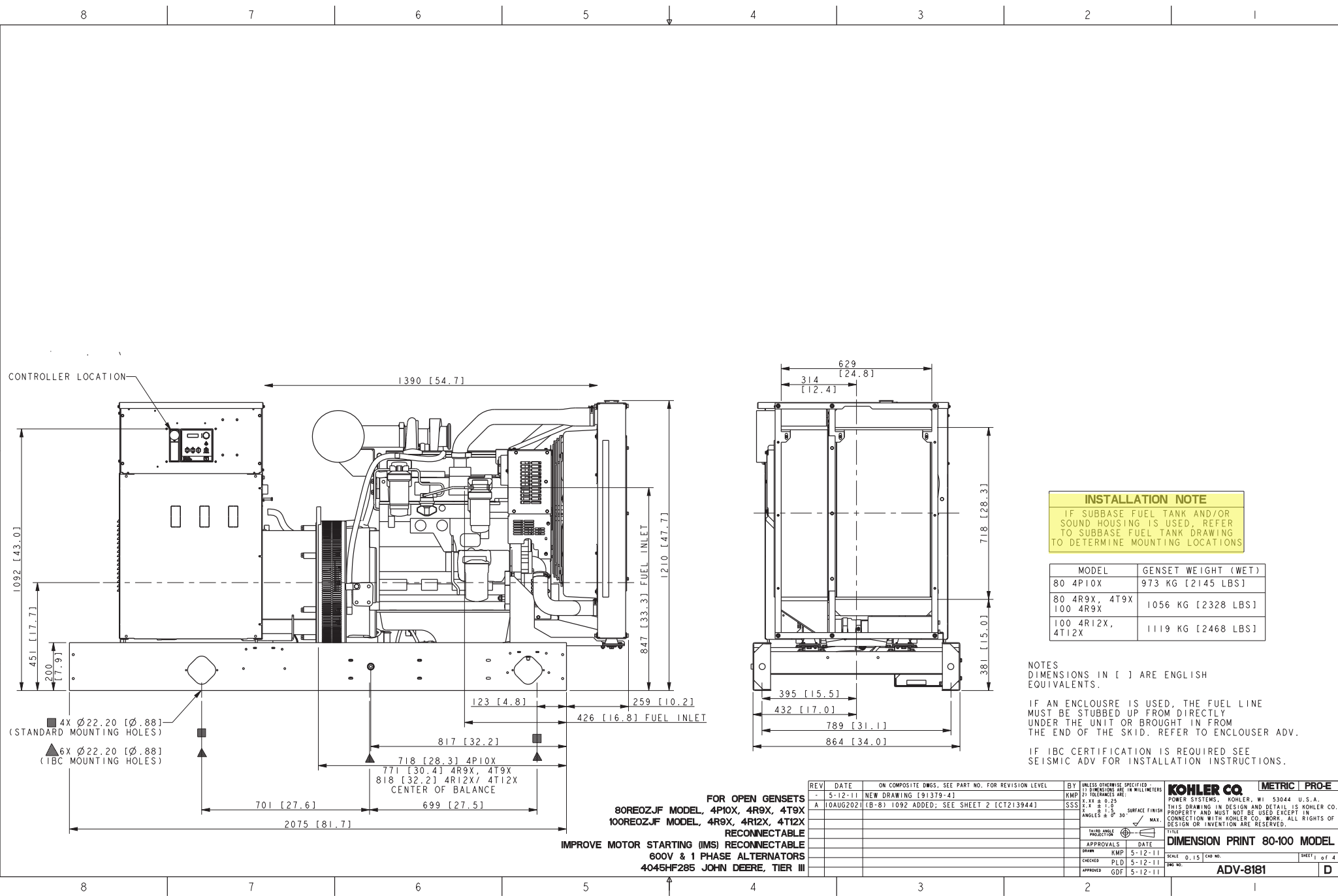

**INSTALLATION NOTE**  
 IF SUBBASE FUEL TANK AND/OR SOUND HOUSING IS USED, REFER TO SUBBASE FUEL TANK DRAWING TO DETERMINE MOUNTING LOCATIONS

MODEL	GENSET WEIGHT (WET)
80 4P10X	973 KG [2145 LBS]
80 4R9X, 4T9X	1056 KG [2328 LBS]
100 4R9X	
100 4R12X, 4T12X	1119 KG [2468 LBS]

NOTES  
 DIMENSIONS IN [ ] ARE ENGLISH EQUIVALENTS.  
 IF AN ENCLOSURE IS USED, THE FUEL LINE MUST BE STUBBED UP FROM DIRECTLY UNDER THE UNIT OR BROUGHT IN FROM THE END OF THE SKID. REFER TO ENCLOSURE ADV.  
 IF IBC CERTIFICATION IS REQUIRED SEE SEISMIC ADV FOR INSTALLATION INSTRUCTIONS.

**FOR OPEN GENSETS**  
 80RE0ZJF MODEL, 4P10X, 4R9X, 4T9X  
 100RE0ZJF MODEL, 4R9X, 4R12X, 4T12X  
**RECONNECTABLE**  
 IMPROVE MOTOR STARTING (IMS) RECONNECTABLE  
 600V & 1 PHASE ALTERNATORS  
 4045HF285 JOHN DEERE, TIER III

REV	DATE	ON COMPOSITE DWGS. SEE PART NO. FOR REVISION LEVEL	BY	UNLESS OTHERWISE SPECIFIED: 1) DIMENSIONS ARE IN MILLIMETERS 2) TOLERANCES ARE: X .XX ± 0.25 Z .X ± 1.5 ANGLES ± 0° 30' / MAX.	POWER SYSTEMS, KOHLER, WI 53044 U.S.A. THIS DRAWING IN DESIGN AND DETAIL IS KOHLER CO. PROPERTY AND MUST NOT BE USED EXCEPT IN CONNECTION WITH KOHLER CO. WORK. ALL RIGHTS OF DESIGN OR INVENTION ARE RESERVED.
-	5-12-11	NEW DRAWING [91379-4]	KMP		<b>KOHLER CO. METRIC PRO-E</b> <b>DIMENSION PRINT 80-100 MODEL</b> SCALE 0.15   CAD NO.   SHEET 1 of 4 TAG NO. <b>ADV-8181</b>   <b>D</b>
A	10AUG2021	(B-8) 1092 ADDED; SEE SHEET 2 [CT213944]	SSS		

8 | 7 | 6 | 5 | 4 | 3 | 2 | 1

D

C

B

A

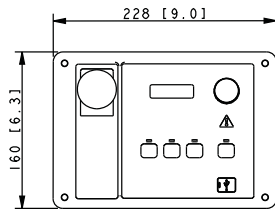

**DEC 3000**

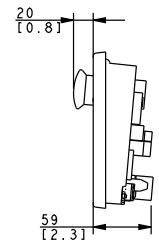

20-300KW  
CONTROLLER

DIMENSIONS IN [ ] ARE ENGLISH EQUIVALENTS.

REV	DATE	ON COMPOSITE DWGS. SEE PART NO. FOR REVISION LEVEL	BY	UNLESS OTHERWISE SPECIFIED:
-	10-15-10	NEW DRAWING [90099]	DJV	1) DIMENSIONS ARE IN MILLIMETERS 2) TOLERANCES ARE: X .XX ± Y .Y ± Z .Z ± ANGLES ±
				SURFACE FINISH / MAX.
				THIRD ANGLE PROJECTION
				APPROVALS DATE
				DRW DJV 10-15-10
				CHKD DJV 10-15-10
				APPRD JDZ 10-15-10

**KOHLER CO. METRIC PRO-E**  
 POWER SYSTEMS, KOHLER, WI 53044 U.S.A.  
 THIS DRAWING IN DESIGN AND DETAIL IS KOHLER CO. PROPERTY AND MUST NOT BE USED EXCEPT IN CONNECTION WITH KOHLER CO. WORK. ALL RIGHTS OF DESIGN OR INVENTION ARE RESERVED.

TITLE: **DIMENSION PRINT, CONTROLLER**  
 SCALE: 0.40 CAD NO. SHEET 1 of 1  
 DWG NO. **ADV-7935**

8 | 7 | 6 | 5 | 4 | 3 | 2 | 1

8 7 6 5 4 3 2 1

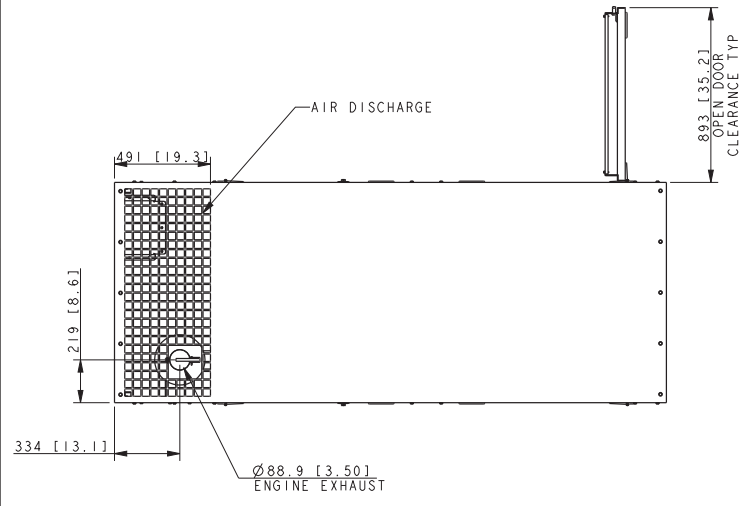

MODEL	ENCLOSURE WEIGHT KG [LBS]
STEEL WEATHER	318 [700]
STEEL SOUND	329 [725]
ALUMINIUM SOUND	204 [450]

**NOTE:**  
 1. IF TANK IS ORDERED, ENCLOSURE MOUNTS DIRECTLY TO TANK  
 2. TANK MAY EXTEND BEYOND ENCLOSURE (DISCHARGE END ONLY)

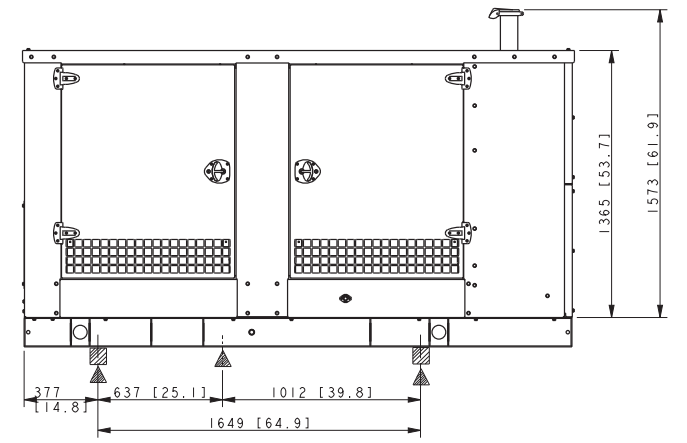
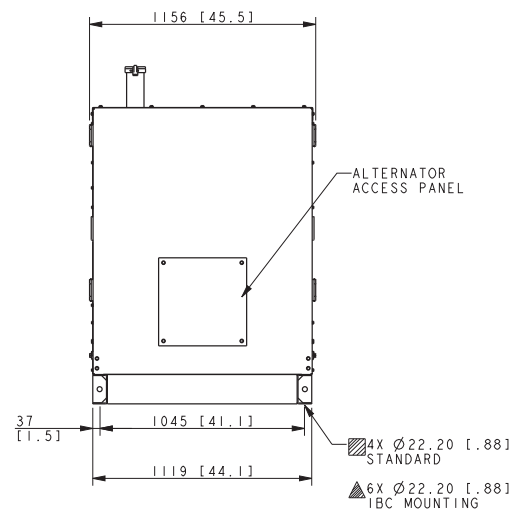
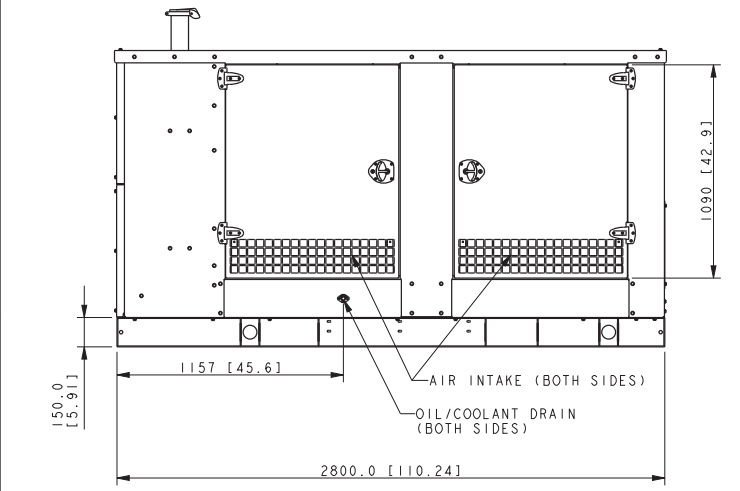

80 MODEL 4S7, 4S9, 4V9, 4P10X, 4R9X, 4T9X  
 100 MODEL 4S9, 4S11, 4V11, 4R9X, 4R12X, 4T12X  
 RECONNECTABLE  
 IMPROVE MOTOR STARTING (IMS)  
 600V & 1 PHASE ALTERNATORS  
 4045HF285 JOHN DEERE TIER III

REV	DATE	ON COMPOSITE DWGS. SEE PART NO. FOR REVISION LEVEL	BY	UNLESS OTHERWISE SPECIFIED: 2) DIMENSIONS ARE IN MILLIMETERS 3) TOLERANCES ARE: L: .13 ± 0.25 F: .13 ± 0.13 ANGLES ± 0° 30' / MAX.	TITLE
B	9-28-10	(A-4) 6X Ø22.20 ADDED, 4X Ø22.20 WAS 4X Ø25.4 *A-3) DIM 635 AND 1014 ADDED [90301]	SAM		<b>KOHLER CO. METRIC PRO-E</b> POWER SYSTEMS, KOHLER, WI 53044 U.S.A. THIS DRAWING IN DESIGN AND DETAIL IS KOHLER CO. PROPERTY AND MUST NOT BE USED EXCEPT IN CONNECTION WITH KOHLER CO. WORK. ALL RIGHTS OF DESIGN OR INVENTION ARE RESERVED. <b>DIMENSION PRINT</b> SCALE: 0.08 CAD NO. SHEET 1 of 2 TAG NO. <b>ADV-7647</b>
C	1-31-11	(A-7) 1159 WAS 1084 [90327]	SAM		
D	12-22-11	(A-4) 4P10X, 4R9X, 4T9X ADDED TO 80 MODEL, 4R9X, 4R12X, 4T12X ADDED TO 100 MODEL [92681]	PKD		
E	2-4-13	(A-1) 1-2 WAS 1-2, SEE SHEET 2 [CT32174]	SAM		
F	10-12-17	(C-7) DIM. Ø88.9 [3.50] ADDED [CT177004]	SRM		
			APPROVED	DATE	
			ALC	7-9-09	

8 7 6 5 4 3 2 1

MODEL	CAPACITY		WEIGHT		HEIGHT		LENGTH		E-VENT, "A"	
	LTR	GAL	KG	LBS	MM	IN	MM	IN	SIZE (IN)	QTY
80/100kW	791	209	366	807	508	20	2800	110.2	3"	2
80 kW	1371	348	482	1062	813	32	2800	110.2	3"/4"	1 EACH
100 kW	1698	448	560	1234	813	32	3400	133.9	4"	2

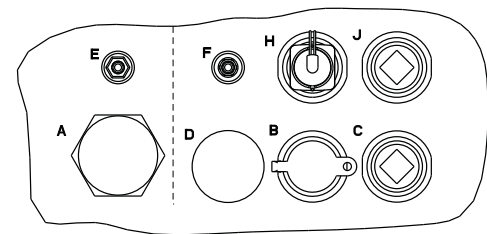
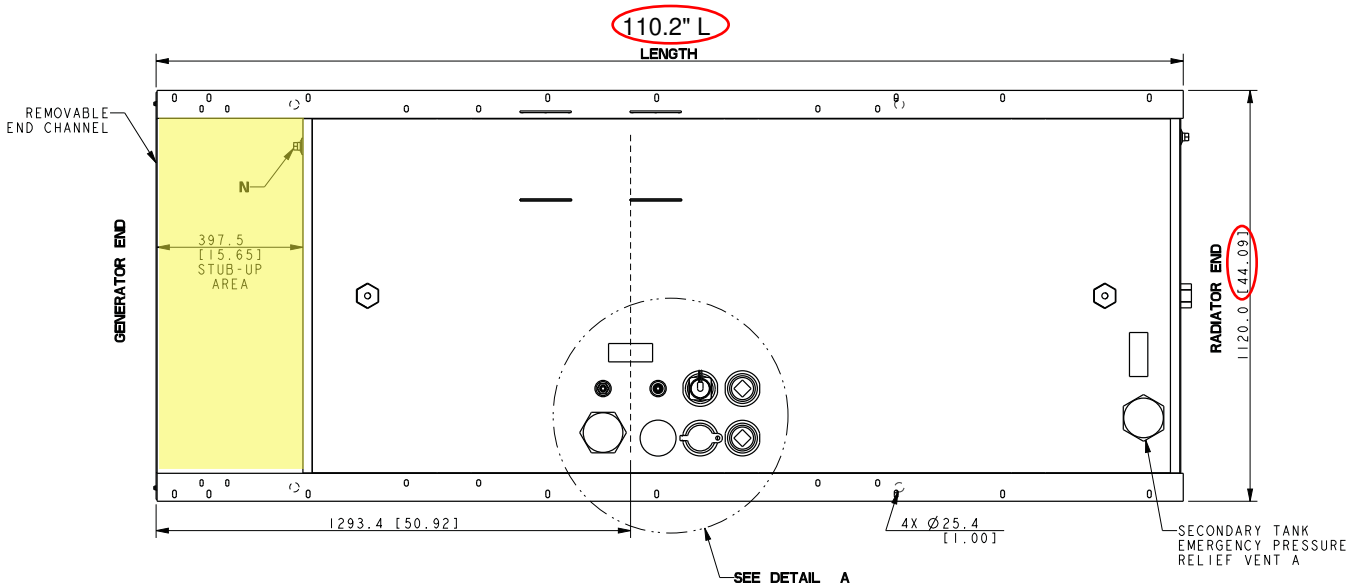

**TANK FITTINGS**

- A. 1/2" NPT EMERGENCY VENT FITTING PER NFPA 30 WITH VENT CAPS
  - B. 2" NPT FUEL FILL FITTING WITH LOCKABLE CAP & 2" RISER
  - C. 2" NPT ADDITIONAL FITTING FOR OPTIONAL ACCESSORY (INSTALL STEEL 2" NPT PIPE PLUG)
  - D. 2" NORMAL VENT FITTING WITH MUSHROOM VENT CAP AND 5" RISER
  - E. 2" NPT FITTING FOR REMOVABLE ENGINE SUPPLY DIP TUBE (3/8" NPT FEMALE WITH CHECK VALVE)
  - F. 2" NPT FITTING FOR REMOVABLE FUEL RETURN DIP TUBE (3/8" NPT FEMALE)
  - H. 2" NPT FUEL LEVEL SENDING UNIT
  - J. 2" NPT ADDITIONAL FITTING FOR OPTIONAL ACCESSORY (INSTALL STEEL 2" NPT PIPE PLUG)
  - M. 1/2" NPT BASIN DRAIN (INSTALL STEEL 1/2" NPT PIPE PLUG)
  - N. 1/2" NPT FOR FUEL IN BASIN SWITCH (INSTALL STEEL 1/2" NPT PIPE PLUG)
- \* FITTING DESIGNATIONS TO CHANGE WITHOUT NOTIFICATION

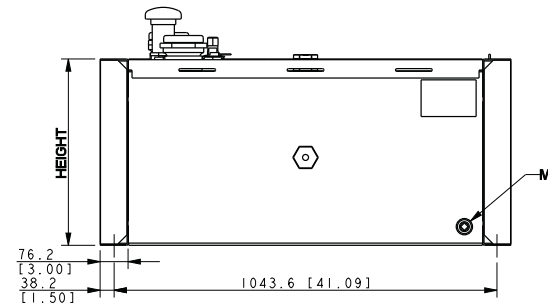
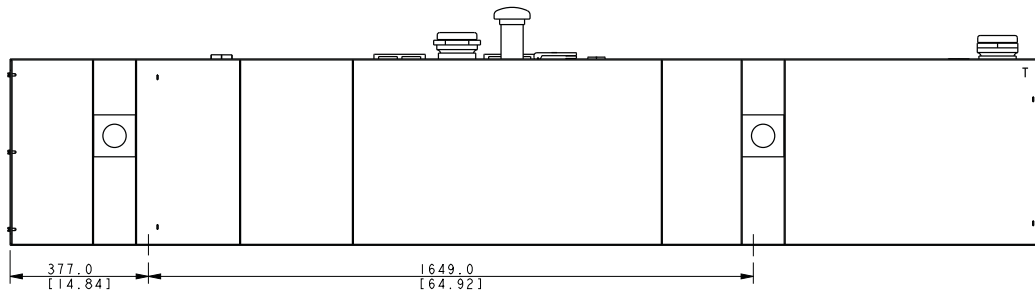

**STANDARD TANK**

80 MODEL 4S7, 4S9, 4V9  
 100 MODEL 4S9, 4S11, 4V11  
 RECONNECTABLE  
 IMPROVE MOTOR STARTING (IMS)  
 600V & 1 PHASE ALTERNATORS  
 4045HF285 JOHN DEERE, TIER III

REV	DATE	ON COMPOSITE DWGS. SEE PART NO. FOR REVISION LEVEL	BY	UNLESS OTHERWISE SPECIFIED: 1) DIMENSIONS ARE IN MILLIMETERS 2) TOLERANCES ARE: X .XX ± 0.25 Y .Y ± 0.15 Z .Z ± 0.15 SURFACE FINISH ANGLES ± 0° 30' / MAX.
-	9-20-12	NEW DRAWING [CT23454]	KMP	
A	5-23-13	(D-8) 348 GAL TANK: VENT SIZE 3"/4" (1 EACH) WAS 3" (2) [CT47790]	PKD	
APPROVALS				DATE
DRAWN				9-20-12
CHECKED				9-20-12
APPROVED				9-20-12

**KOHLER CO. METRIC PRO-E**  
 POWER SYSTEMS, KOHLER, WI 53044 U.S.A.  
 THIS DRAWING IN DESIGN AND DETAIL IS KOHLER CO. PROPERTY AND MUST NOT BE USED EXCEPT IN CONNECTION WITH KOHLER CO. WORK. ALL RIGHTS OF DESIGN OR INVENTION ARE RESERVED.

**TITLE**  
**DIMENSION PRINT**

SCALE 0.15 CAD NO. SHEET 1 of 1  
 DWG NO. **ADV-8519**

**KOHLER®**

# Wiring Schematics

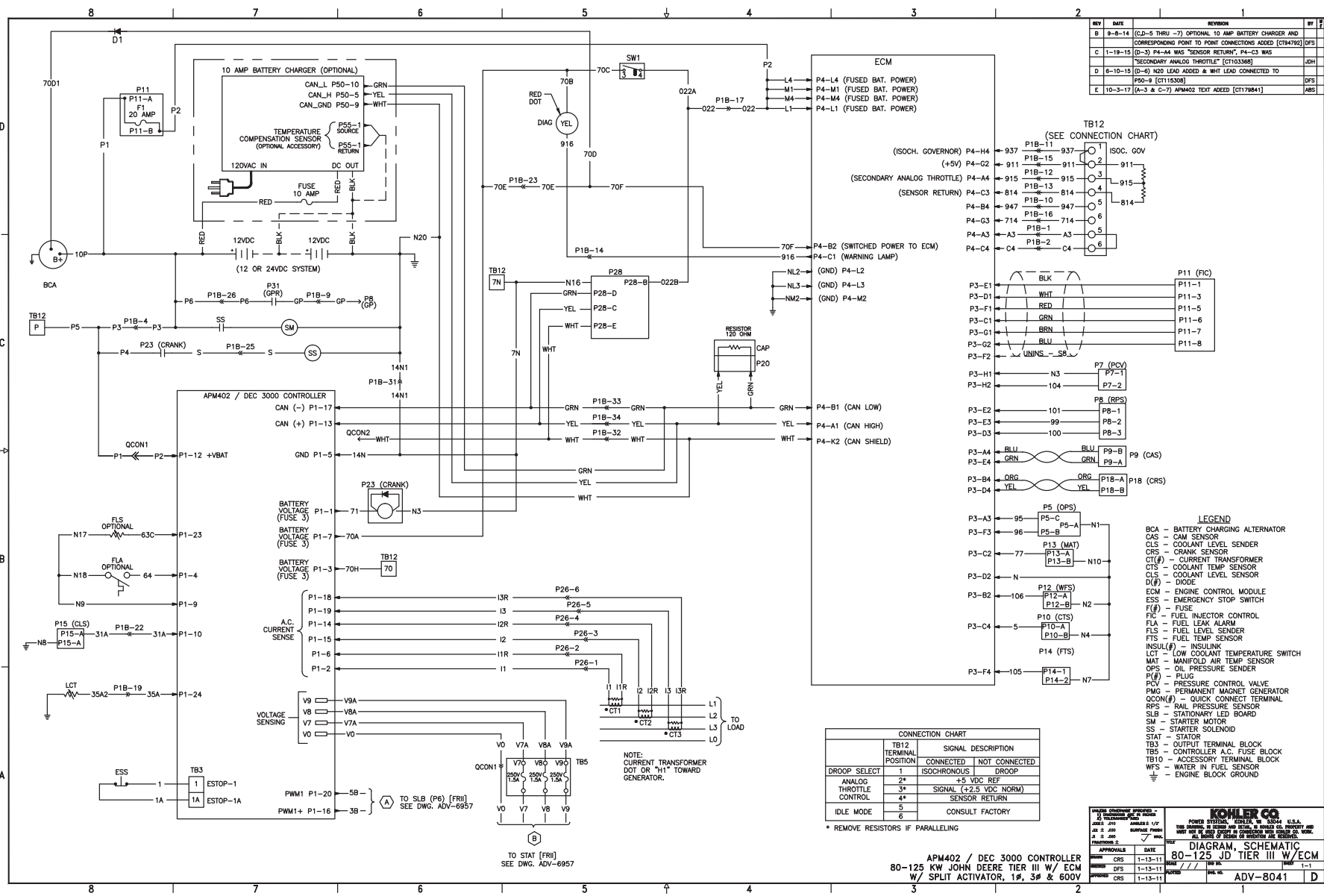

REV	DATE	REVISION	BY
B	9-8-14	(C,D)-5 THRU -7) OPTIONAL 10 AMP BATTERY CHARGER AND CORRESPONDING POINT TO POINT CONNECTIONS ADDED [C194792]	DPS
C	1-19-15	(D-3) P4-M4 WAS "SENSOR RETURN", P4-C3 WAS "SECONDARY ANALOG THROTTLE" [C1103368]	JDH
D	8-10-15	(D-5) NO LOAD ADDED & WHT LEAD CONNECTED TO P50-9 [C1183308]	DPS
E	10-3-17	(A-3 & C-7) APM402 TEXT ADDED [C119841]	AMS

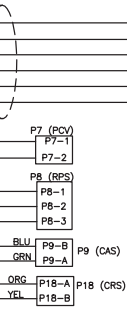
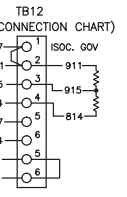

LEGEND

- BCA - BATTERY CHARGING ALTERNATOR
- CAS - CAN SENSOR
- CLS - COOLANT LEVEL SENDER
- CRS - CRANK SENSOR
- CT(A) - CURRENT TRANSFORMER
- CTS - COOLANT TEMP SENSOR
- CLS - COOLANT LEVEL SENSOR
- D(Ø) - DIODE
- ECM - ENGINE CONTROL MODULE
- ESS - EMERGENCY STOP SWITCH
- F(Ø) - FUSE
- FLA - FUEL INJECTOR CONTROL
- FLA - FUEL LEAK ALARM
- FLS - FUEL LEVEL SENDER
- FTS - FUEL TEMP SENSOR
- INSUL(Ø) - INSULINK
- LCT - LOW COOLANT TEMPERATURE SWITCH
- MAT - MANIFOLD AIR TEMP SENSOR
- OPS - OIL PRESSURE SENDER
- P(Ø) - PLUG
- PCV - PRESSURE CONTROL VALVE
- PMG - PERMANENT MAGNET GENERATOR
- QCON(Ø) - QUICK CONNECT TERMINAL
- RPS - RAIL PRESSURE SENSOR
- SLB - STATIONARY LED BOARD
- SM - STARTER MOTOR
- SS - STARTER SOLENOID
- STAT - STATOR
- TB3 - OUTPUT TERMINAL BLOCK
- TB5 - CONTROLLER A.C. FUSE BLOCK
- TB10 - ACCESSORY TERMINAL BLOCK
- WFS - WATER IN FUEL SENSOR
- ⊕ - ENGINE BLOCK GROUND

CONNECTION CHART

DROOP SELECT	TB12 TERMINAL POSITION	SIGNAL DESCRIPTION	
		CONNECTED	NOT CONNECTED
1	1	ISOCHRONOUS	DROOP
2*	2*	+5 VDC REF	
3*	3*	SIGNAL (+2.5 VDC NORM)	
4*	4*	SENSOR RETURN	
5	5	CONSULT FACTORY	
6	6	CONSULT FACTORY	

APM402 / DEC 3000 CONTROLLER  
 80-125 KW JOHN DEERE TIER III W/ ECM  
 W/ SPLIT ACTIVATOR, 1#, 3# & 600V

APPROVALS

APPROVED	DATE
CRS	1-13-11
CRS	1-13-11
CRS	1-13-11

DIAGRAM - SCHEMATIC  
 80-125 JD TIER III W/ECM  
 ADV-8041

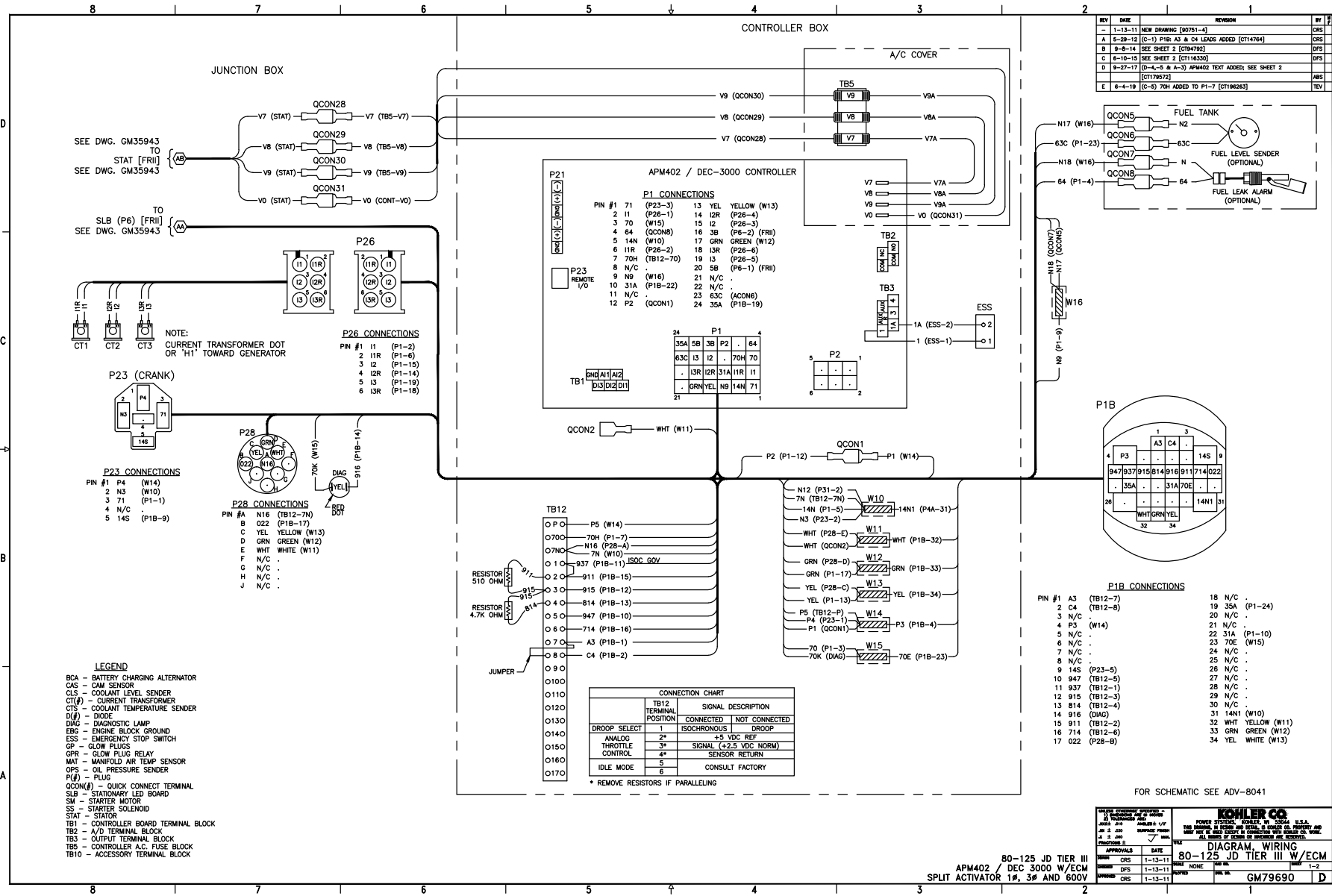

REV	DATE	REVISION	BY
-	1-13-11	NEW DRAWING (80751-4)	CRS
A	5-29-12	(C-1) P1B A3 & C4 LEADS ADDED [C114764]	CRS
B	9-8-14	SEE SHEET 2 (C104792)	OPS
C	6-10-15	SEE SHEET 2 (C114330)	OPS
D	9-27-17	(D-4, -5 & A-3) APM402 TEXT ADDED; SEE SHEET 2 [C1179872]	ABS
E	6-4-19	(C-5) 70H ADDED TO P1-7 [C1192683]	TRV

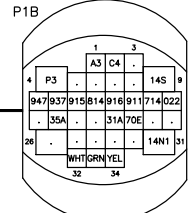
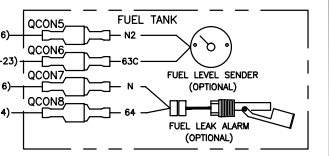

**P1B CONNECTIONS**

PIN #1	A3 (TB12-7)	18	N/C
2	C4 (TB12-8)	19	35A (P1-24)
3	N/C	20	N/C
4	P3 (W14)	21	N/C
5	N/C	22	31A (P1-10)
6	N/C	23	70E (W15)
7	N/C	24	N/C
8	N/C	25	N/C
9	14S (P23-5)	26	N/C
10	947 (TB12-5)	27	N/C
11	937 (TB12-1)	28	N/C
12	915 (TB12-3)	29	N/C
13	814 (TB12-4)	30	N/C
14	916 (DIAG)	31	14N1 (W10)
15	911 (TB12-2)	32	WHT WHITE (W11)
16	714 (TB12-6)	33	GRN GREEN (W12)
17	022 (P28-8)	34	YEL WHITE (W13)

FOR SCHEMATIC SEE ADV-8041

APPROVALS	DATE	REVISION	BY
CRS	1-13-11		
CRS	1-13-11		
CRS	1-13-11		

**DIAGRAM WIRING**

ITEM	QTY	DESCRIPTION	UNIT
80-125 JD TIER III			
APM402 / DEC 3000 W/ECM			
SPLIT ACTIVATOR 19, 3# AND 600V			
80-125 JD TIER III W/ECM			
GM79690			

80-125 JD TIER III  
APM402 / DEC 3000 W/ECM  
SPLIT ACTIVATOR 19, 3# AND 600V



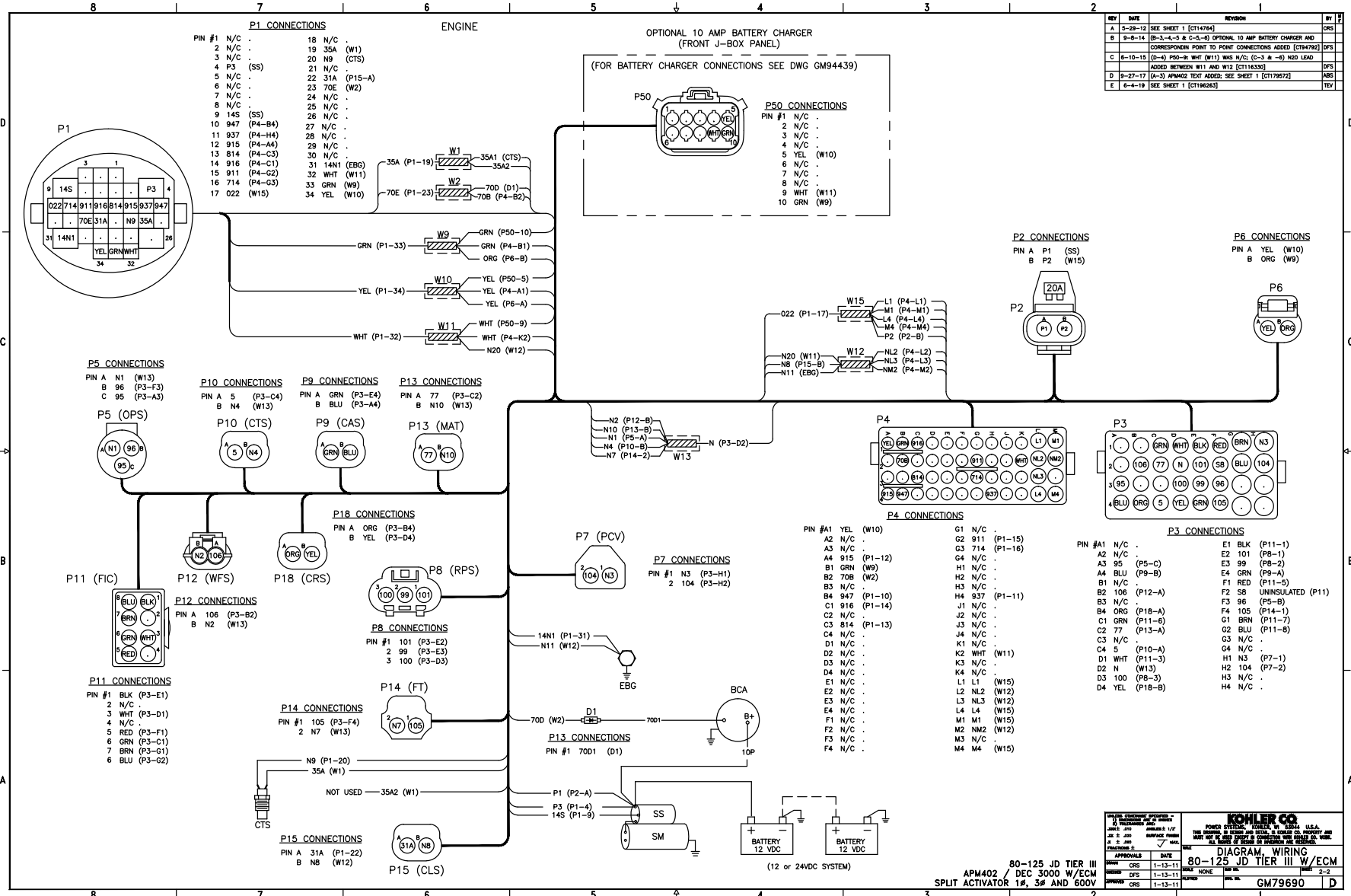

REV	DATE	REVISION	BY
A	5-29-12	SEE SHEET 1 [C114764]	CRS
B	9-8-14	[B-3,-4,-5 & C-5,-6] OPTIONAL 10 AMP BATTERY CHARGER AND CORRESPONDING POINT TO POINT CONNECTIONS ADDED [C14762] DFS	
C	6-10-15	[C-4] P50-B: WHT (W11) WAS N/C; [C-3 & B-6] N20 LEAD ADDED BETWEEN W11 AND W12 [C114630] DFS	
D	9-27-17	[A-3] SPRING TEST KNOCK; SEE SHEET 1 [C1179672] AMS	
E	6-4-19	SEE SHEET 1 [C1196263] TEV	

APPROVALS		DATE
DESIGNED BY	CRS	1-13-11
CHECKED BY	DFS	1-13-11
APPROVED BY	CRS	1-13-11
NONE		
DATE		
80-125 JD TIER III W/ECM		
DIAGRAM, WIRING		
80-125 JD TIER III W/ECM		
APM402 / DEC 3000 W/ECM		
SPLIT ACTIVATOR 1#, 3# AND 600V		
PARTS LIST		REV
80-125 JD TIER III W/ECM		2-2
GM79690		D

8

7

6

5

4

3

2

1

**P29 2 AMP RELAY OUTPUT (2.1) CONNECTIONS.**  
 P29-NC 2.1 RELAY NORMALLY CLOSED  
 P29-COM 2.1 RELAY COMMON  
 P29-NO 2.1 RELAY NORMALLY OPEN

**P30 2 AMP RELAY OUTPUT (2.2) CONNECTIONS.**  
 P30-NC 2.2 RELAY NORMALLY CLOSED  
 P30-COM 2.2 RELAY COMMON  
 P30-NO 2.2 RELAY NORMALLY OPEN

**P31 2 AMP RELAY OUTPUT (2.3) CONNECTIONS.**  
 P31-NC 2.3 RELAY NORMALLY CLOSED  
 P31-COM 2.3 RELAY COMMON  
 P31-NO 2.3 RELAY NORMALLY OPEN

**P32 10 AMP RELAY OUTPUT (2.4 & 2.5) CONNECTIONS.**  
 P32-NO 2.4 RELAY NORMALLY OPEN  
 P32-COM 2.4 RELAY COMMON  
 P32-NC 2.4 RELAY NORMALLY CLOSED  
 P32-NO 2.5 RELAY NORMALLY OPEN  
 P32-COM 2.5 RELAY COMMON  
 P32-NC 2.5 RELAY NORMALLY CLOSED

**P27 CAN TERMINATOR CONNECTIONS.**  
 PLACE THE P27 JUMPER ON THE "IN" PINS

**P28 SINGLE-ENDED (0-5V) ANALOG INPUT CONNECTIONS.**  
 P28-GND AGND ANALOG RETURN  
 P28-VN2 NO CONNECTION  
 P28-VP2 ACH2 SIGNAL  
 P28-+5V SUPPLY (0.05 AMP MAX)  
 P28-GND AGND ANALOG RETURN  
 P28-VN1 NO CONNECTION  
 P28-VP1 ACH1 SIGNAL  
 P28-+5V SUPPLY (0.05 AMP MAX)

**P28 DIFFERENTIAL (+/-3V) ANALOG INPUT CONNECTIONS.**  
 P28-GND AGND ANALOG REFERENCE  
 P28-VN2 ACH2 NEGATIVE DIFFERENTIAL SIGNAL  
 P28-VP2 ACH2 POSITIVE DIFFERENTIAL SIGNAL  
 P28-+5V SUPPLY (0.05 AMP MAX)  
 P28-GND AGND ANALOG RETURN  
 P28-VN1 ACH1 NEGATIVE DIFFERENTIAL SIGNAL  
 P28-VP1 ACH1 POSITIVE DIFFERENTIAL SIGNAL  
 P28-+5V SUPPLY (0.05 AMP MAX)

NOTE: CONTACT AUTHORIZED DISTRIBUTOR TO DEFINE P28 A/D INPUTS.

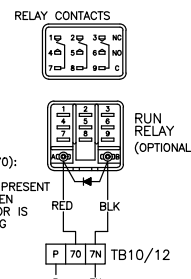

RELAY CONTACTS



RUN RELAY (OPTIONAL)

NOTE: CONTACT AUTHORIZED DISTRIBUTOR TO DEFINE P28 A/D INPUTS.

NOTE: IF SHUNT TRIP OR FAILURE RELAY IS NOT USED, DISCONNECT & TAPE LEADS 2 & 32A.

NOTE: TRANSFER SWITCH TERMINAL DESIGNATIONS MAY VARY FROM THOSE SHOWN HERE. VERIFY THE CORRECT DESIGNATIONS USING THE APPROPRIATE TRANSFER SWITCH WIRING DIAGRAM.

(TERMINALS 3 AND 4: REMOTE START SWITCH OR ENGINE START CONTACTS ON TRANSFER SWITCH)

REV	DATE	REVISION	BY
F	04-28-10	(0-2-3) COMMENT "NOT AVAILABLE AS A STANDALONE KIT", "OPTIONAL, INCLUDED IN SHUNT TRIP KIT" ARE ADDED. SEE SHEET 2 (01168997)	SSR
G	2-6-10	[A-B-6, 7, 8] ADDED GROUND FAULT RELAY INPUT; TB1-D11 LOW FUEL PRESSURE WAS EXISTING OVER VOLTAGE (AL3AL2M) [A-B-1, 2, 3] ADDED NOTE 5 AND 6 IN INSTALLATION NOTES [01193015]	SSR

**LEGEND**  
 P(#)- PLUG  
 QCON(#)- QUICK CONNECT  
 TB(#)- TERMINAL BLOCK  
 W(#)- SONIC WELD

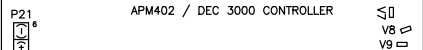
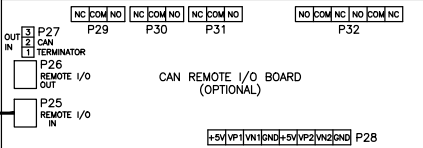

**P1/TB1 NOTE:**  
 1.) DIGITAL INPUT 1 EXISTS IN P1-4 & TB1-D11  
 2.) ANALOG INPUT 1 EXISTS IN P1-24 & TB1-A11  
 3.) ANALOG INPUT 2 EXISTS IN P1-23 & TB1-A12

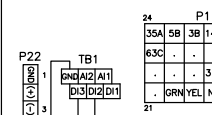

**AUX WARNING SWITCH (CUSTOMER PROVIDED)**  
 NOTE: NOT AVAILABLE FOR USE ON 40-60REOZK MODELS (SEE INSTALLATION NOTE 4)

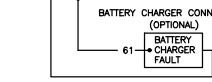

**P21 RS485 NON-ISOLATED CONNECTIONS.**  
 P21-1 GND  
 P21-2 +  
 P21-3 -  
 P21-4 GND  
 P21-5 +  
 P21-6 -

**TB1 ANALOG/DIGITAL INPUT FACTORY SETTINGS**  
 TB1-D11 DCH1 LOW FUEL PRESSURE  
 TB1-D12 DCH2 AUX WARNING  
 TB1-D13 DCH3 BATTERY CHARGER FAULT WARNING  
 TB1-A1 ACH1 NO FUNCTION  
 TB1-A2 ACH2 NO FUNCTION  
 TB1-GND A/DGND ANALOG/DIGITAL RETURN

NOTE: TB1 A/D INPUTS MAY BE REDEFINED - FACTORY DEFAULTS LISTED. CONTACT AUTHORIZED DISTRIBUTOR FOR DETAILS.

**TB2 RELAY OUTPUT**  
 TB2-D11 DCH1 (RELAY COMMON) COMMON FAULT  
 TB2-COM (RELAY COMMON) COMMON FAULT  
 TB2-NO (RELAY NORMALLY OPEN) COMMON FAULT  
 TB2-NC (RELAY NORMALLY CLOSED) COMMON FAULT

NOTE: TB2 RELAY OUTPUT MAY BE REDEFINED - FACTORY DEFAULTS LISTED. CONTACT AUTHORIZED DISTRIBUTOR FOR DETAILS. CUSTOMER TO CONNECT TO TB2 UNLESS SHUNT TRIP IS USED. IF SHUNT TRIP IS USED, CUSTOMER TO CONNECT TO DCB2 FOR COMMON FAULT.

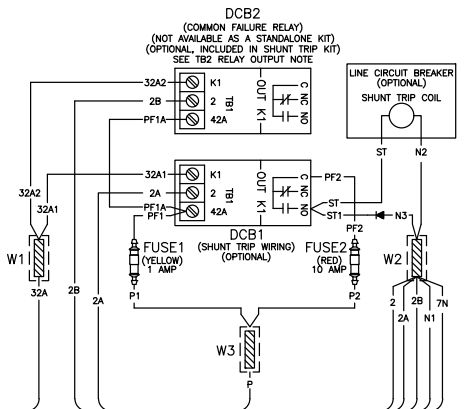

**INSTALLATION NOTES:**

- FOR FIELD INSTALLATION A MAXIMUM OF TWO WIRE TERMINALS PER TERMINAL STRIP SCREW IS RECOMMENDED UNLESS OTHERWISE NOTED ON THE WIRING DIAGRAM. DO NOT EXTEND ABOVE THE TERMINAL STRIP BARRIER.
- GENERATOR SETS WITH FUEL TANKS HAVE THE FUEL IN BASIN SWITCH TIED TO DIGITAL INPUT 1 (TB1-D11) VIA P1-4 AND FUEL LEVEL SENDER TIED TO ANALOG INPUT 2 (TB1-A12) VIA P1-23
- COOLANT LEVEL SENSOR ON ALL GENSETS IS TIED TO ANALOG INPUT 1 (TB1-A12) VIA P1-24.
- 40-60 REOZK MODELS HAVE COLD START IGNITION RELAY TIED TO DIGITAL INPUT 2 (TB1-D12)
- GROUND FAULT WARNING : CONNECT TO REMOTE I/O BOARD ON 20REOZK-C.
- KEYSWITCH AVAILABLE ON SELECT MODELS ONLY.

<p>UNLESS OTHERWISE SPECIFIED, ALL DIMENSIONS ARE IN INCHES AND DECIMALS THEREOF ARE IN THIRDS OF AN INCH. DIMENSIONS ARE TO CENTER UNLESS OTHERWISE SPECIFIED.</p>		<p><b>WALTRONICS</b>        POWER SYSTEMS, MODEL 10, 2004 U.S.A.        10000 WATTS, 100 AMP, 120VAC, 50/60 HZ        10000 WATTS, 100 AMP, 240VAC, 50/60 HZ        10000 WATTS, 100 AMP, 240VAC, 50/60 HZ</p>	
DATE	9-16-10	REV	1-2
APPROVED		DATE	9-16-10
DESIGNED	DPS	DATE	9-16-10
CHECKED	CMS	DATE	9-16-10
DATE	9-16-10	REV	1-2
<p>DIAGRAM, DEC3000/APM402        ACCY INTERCONNECTION</p>		<p>GM78246</p>	

APM402 / DEC 3000 ACCESSORIES

8

7

6

5

4

3

2

1

REV	DATE	REVISION	BY
F	04-28-18	(8-6-2) COMMENT "APM402 / DEC 3000 ACCESSORIES" IS ADDED	SBR
		SEE SHEET 1 (C118097)	SBR
G	2-6-19	SEE SHEET 1 (C1182515)	SBR

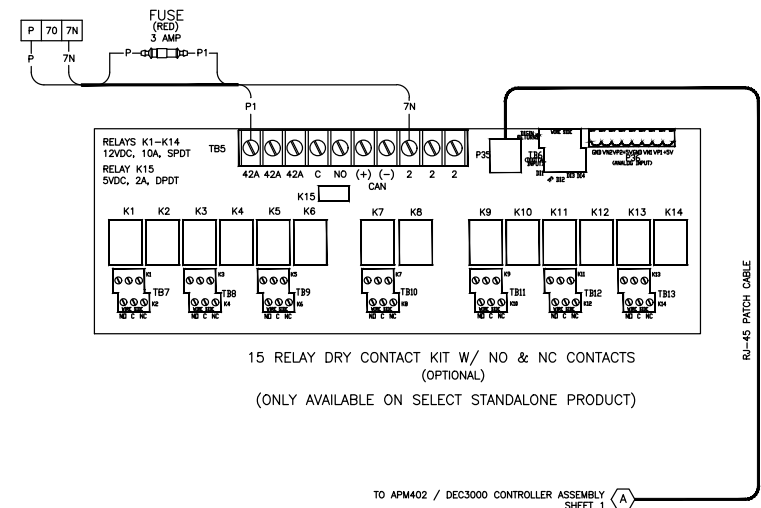
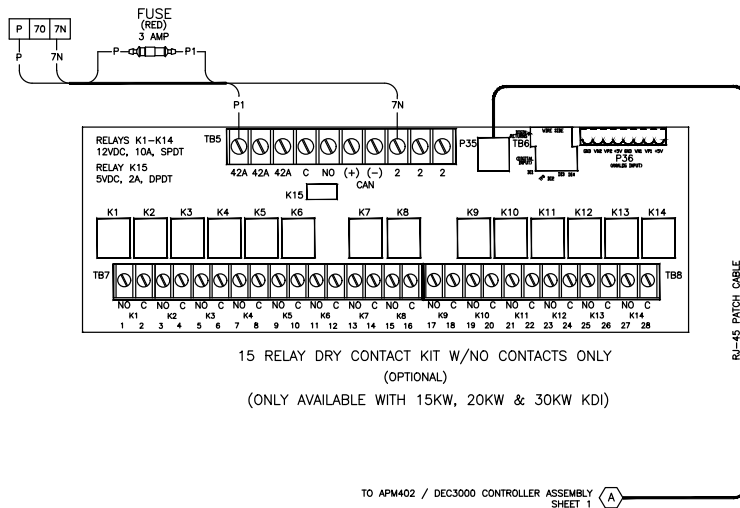

APM402 / DEC 3000 ACCESSORIES

APPROVALS DESIGNED: DFS CHECKED: CRS DATE: 9-18-15	DATE: 9-18-15 DRAWN: DFS DATE: 9-18-15	<b>KOHLER CO.</b> POWER SYSTEMS DIVISION 1000 W. 100TH AVENUE DENVER, CO 80202 TEL: 303.440.1000 FAX: 303.440.1001 WWW.KOHLER.COM	<b>DIAGRAM, DEC3000/APM402 ACCY INTERCONNECTION</b> SHEET 2-2 P&ID NO. GM78246
---	--	---	--

**KOHLER®**

# Miscellaneous

**OVERVIEW:**  
 THE AUTOMATIC MULTI-LEVEL FLOAT/ EQUALIZE CHARGER SPECIFIED BELOW IS INTENDED TO CHARGE ENGINE STARTING BATTERIES EITHER INDEPENDENT OR IN CONJUNCTION WITH AN ENGINE DRIVEN CHARGING SYSTEM.

**BATTERY TYPES TO BE CHARGED:**  
 LEAD ACID  
 GEL CELL

**INPUT:**  
 INPUT VOLTAGE: 90-135 VOLTS AC  
 INPUT FREQUENCY: 50/60 Hz

**INPUT LEAD:**  
 APPROXIMATELY 1.8M (72") (REF) TYPE SJTOW -40°C TO 105°C UL RATED WIRE. TERMINATED IN PRE-MOLDED US STYLE 120 V 3 PRONG AC PLUG.

**DC OUTPUT:**  
 AUTOMATIC FLOAT EQUALIZE  
 STEADY FULL LOAD CURRENT: 6 AMPS  
 BULK 11.8-14.0 VOLTS @ 5.0-6.0 AMPS  
 ABSORPTION VOLTAGE: 14.0-14.5 VOLTS @ 1.5-5.0 AMPS  
 FLOAT VOLTAGE: 13.3-14.5 VOLTS @ 0.1-1.5 AMPS  
 BULK TO ABSORPTION TRANSITION: 14.0 VOLTS  
 ABSORPTION TO FLOAT TRANSITION: 1.5 AMPS  
 CURRENT LIMIT 7 AMPS  
 OUTPUT POWER LIMITS: 70 +2/-5 WATTS  
 FLOAT TO ABSORPTION TRANSITION: 2.06 VOLTS PER CELL  
 LINE REGULATION ACROSS INPUT  
 VOLTAGE RANGE: 1%  
 SPARK PROTECTION CONNECTION AND OPERATION

**OUTPUT LEAD:**  
 APPROX. 1.2M (48") (REF) TYPE SJTOOW -50°C TO 105°C UL RATED WIRE WITH RED AND BLACK WIRE INSULATION. TERMINATED IN 9.5 mm (REF) RING STYLE TERMINALS.

**FUSES:**  
 THE FUSE MUST BE LOCATED APPROXIMATELY 5" FROM RING TERMINAL ON RED OUTPUT LEAD.  
 DC OUTPUT: RATED PER UL (125% RATED OUTPUT)

**ISOLATION:**  
 INPUT TO OUTPUT: 2500V

**ENVIRONMENTAL:**  
 STORAGE TEMPERATURE RANGE: -40 TO +70°C (-40 TO +158°F)  
 OPERATING TEMPERATURE RANGE: -40 TO +70°C (-40 TO +158°F)  
 HUMIDITY: 0 TO 100% (CONDENSING)  
 VIBRATION AND SHOCK: UL991

**REVERSE POLARITY PROTECTION:**  
 THE CHARGER SHALL SUSTAIN NO DAMAGE WHEN INCORRECTLY CONNECTED TO THE BATTERY IN REVERSE ORIENTATION.

**MOUNTING:** SHALL HAVE INTEGRAL MTG. FLANGES.

**ENCLOSURE:**  
 SHALL PROTECT THE CHARGER COMPONENTS FROM RAIN, SNOW, DUST AND DRIPPING WATER. ALL INTERNAL COMPONENTS PROTECTED FROM WATER DROPLETS.

**INDICATORS:**  
 SHALL HAVE CHARGE INDICATOR LAMP TO INDICATE BULK CHARGE AND FLOAT CHARGE CYCLES.

**OPERATIONAL:**  
 CAPABLE OF WITHSTANDING AN INDEFINITE OUTPUT SHORT CIRCUIT WITHOUT DAMAGE TO THE CHARGER. SHALL OPERATE PROPERLY AND SUSTAIN NO DAMAGE WHEN CONNECTED TO INPUT POWER WHILE CONNECTED TO THE BATTERY AND CHARGING SYSTEM OF ENGINE WHILE ENGINE IS CRANKED, RUNNING OR SHUTDOWN.

**DOCUMENTATION:**  
 THERE SHALL BE AN INSTALLATION / OPERATIONAL MANUAL SUPPLIED WITH EACH CHARGER. PER KOHLER SUPPLIED ARTWORK.

**CERTIFICATIONS (US AND CANADA):**  
 MUST COMPLY WITH UL2200  
 UL1236  
 MUST MEET CSA REQUIREMENTS  
 EMI / RFI FCC CLASS B COMPLIANT AFTER CHARGER DATE CODE 8/26/04

**PACKAGING LABEL:**  
 THE PACKAGING LABEL SHALL CONTAIN THE FOLLOWING INFORMATION:  
 KOHLER P/N  
 DESCRIPTION - BATTERY CHARGER  
 MFG. MODEL NO.  
 MFG. PART NUMBER  
 DATE CODE

**WARRANTY:**  
 2 YEAR FROM DATE OF PURCHASE FROM MANUFACTURE.

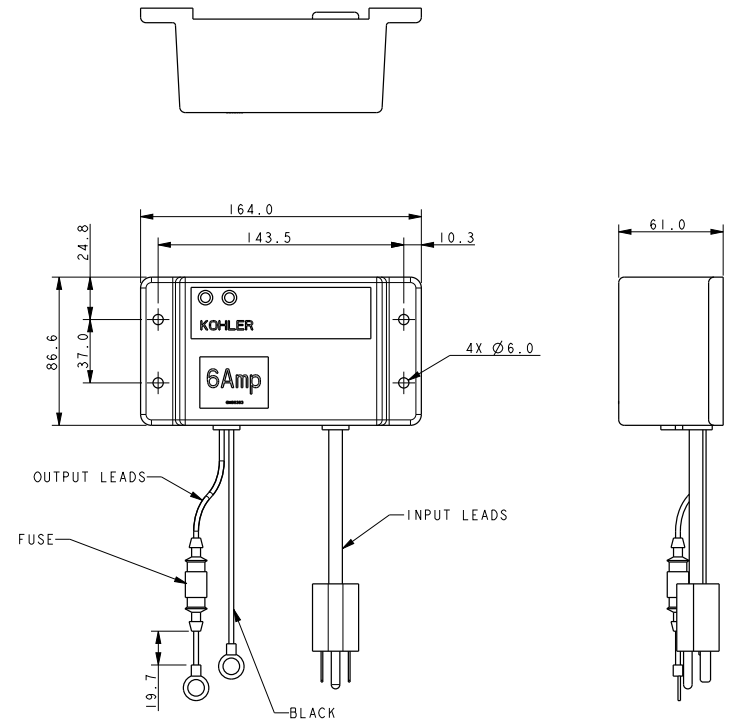

**PRODUCT LABELING:**  
 THE LABEL ATTACHED TO THE CHARGER SHALL HAVE THE FOLLOWING INFORMATION:  
 UL LISTING  
 KOHLER PART NUMBER  
 DESCRIPTION OF ALL INDICATOR  
 ALLOWABLE RANGE OF BATTERY UNIT CAPACITY  
 ALLOWABLE BATTERY TYPES  
 OUTPUT CURRENT AND VOLTAGE  
 INPUT VOLTAGE AND FREQUENCY

REV	DATE	ON COMPOSITE DWGS. SEE PART NO. FOR REVISION LEVEL	BY	UNLESS OTHERWISE SPECIFIED: 2) DIMENSIONS ARE IN MILLIMETERS	<b>KOHLER CO. METRIC PRO-E</b> POWER SYSTEMS, KOHLER, WI 53044 U.S.A. THIS DRAWING IN DESIGN AND DETAIL IS KOHLER CO. PROPERTY AND MUST NOT BE USED EXCEPT IN CONNECTION WITH KOHLER CO. WORK. ALL RIGHTS OF DESIGN OR INVENTION ARE RESERVED. TITLE: <b>BATTERY CHARGER 12V, 6A</b> SCALE: 0.50 CAD NO. SHEET 1 of 1 DWG NO. <b>GM96383</b>
-	11-8-16	NEW DRAWING (CT164513)	SAM	1) TOLERANCES ARE: X .XX ± 0.25 Y .X ± 1.5 SURFACE FINISH Z .P ± 1.5 MAX. ANGLES ± 0° 30'	
				THIRD ANGLE PROJECTION 	
			APPROVALS	DATE	
			DRAWN: SAM	11-8-16	
			CHECKED: SAM	11-8-16	
			APPROVED: KJB	11-8-16	

KIT NUMBER	ITEM I	VIEW	DESCRIPTION
GM96391-KA1	GM96383	VIEW 1	6A BATTERY CHARGER 12V, 6A
GM96391-KA2	GM96383 (2)	VIEW 2	6A BATTERY CHARGER 24V, 6A
GM96391-KA3	GM96383 (2)	VIEW 2	6A BATTERY CHARGER 24V, 6A

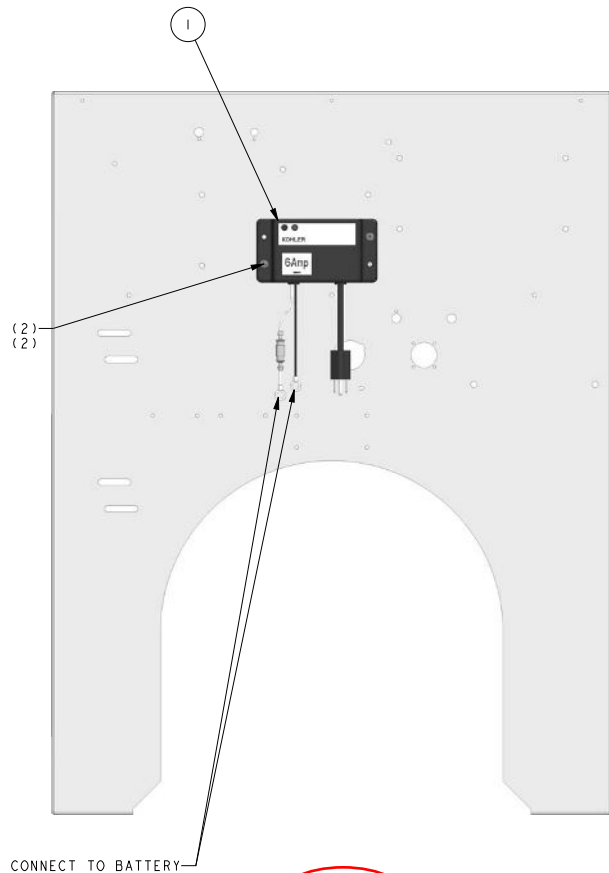

**VIEW 1**

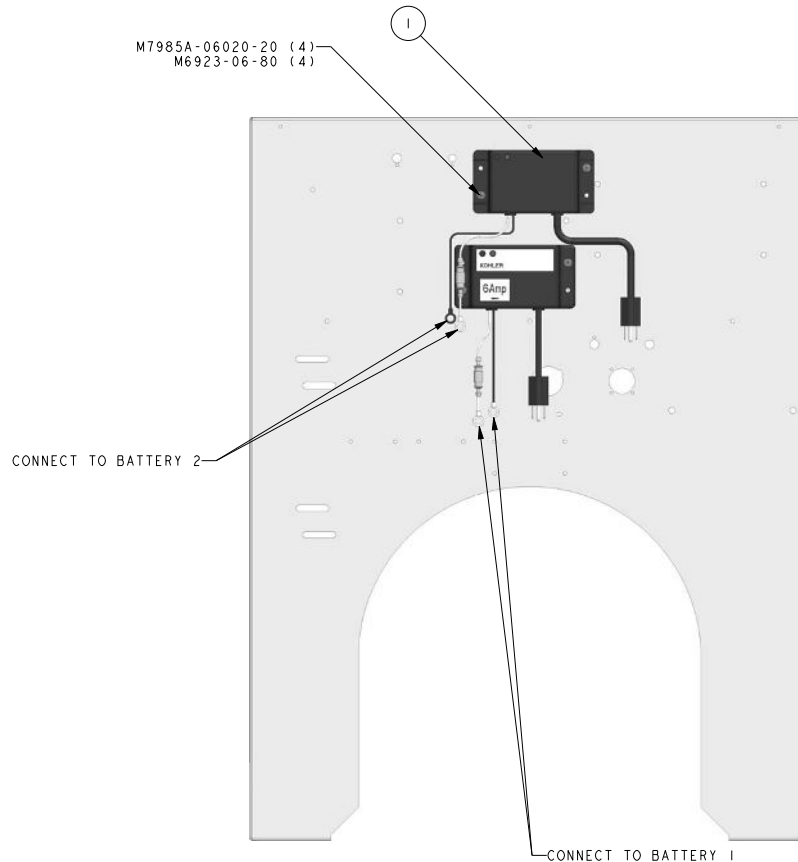

**VIEW 2**

NOTE:  
 FOR GM96391-KA2 24V CHARGER IT IS NECESSARY  
 TO REPLACE 280133 (BATTERY CABLE) GM20748 AND  
 GM20744 (BATTERY BOOTS) WITH X-545-65 (BATTERY CABLE)  
 345039 AND 345056 (BATTERY TERMINALS)

REV	DATE	ON COMPOSITE DWGS. SEE PART NO. FOR REVISION LEVEL	BY	UNLESS OTHERWISE SPECIFIED: 1) DIMENSIONS ARE IN MILLIMETERS 2) TOLERANCES ARE: X .XX ± 0.25 Y .Y ± 0.15 SURFACE FINISH Z .Z ± 0.15 ANGLES ± 0° 30' MAX.																
-	3-4-15	NEW DRAWING (CT107416)	SAK																	
A	12-23-16	(C-8) M7985A-06020-20 (2) WAS M933-06020-60 (2); (D-4) M7985A-06020-20 (4) WAS M933-06020-60 (4) (CT168611)	PAS																	
<table border="1"> <tr> <td>APPROVALS</td> <td>DATE</td> </tr> <tr> <td>DRWN SAK</td> <td>3-4-15</td> </tr> <tr> <td>CHECKED A.J.T</td> <td>3-4-15</td> </tr> <tr> <td>APPROVED JMS</td> <td>3-4-15</td> </tr> </table>				APPROVALS	DATE	DRWN SAK	3-4-15	CHECKED A.J.T	3-4-15	APPROVED JMS	3-4-15	<table border="1"> <tr> <td colspan="2"> <b>KOHLER CO. METRIC PRO-E</b>            POWER SYSTEMS, KOHLER, WI 53044 U.S.A.            THIS DRAWING IN DESIGN AND DETAIL IS KOHLER CO.            PROPERTY AND MUST NOT BE USED EXCEPT IN            CONNECTION WITH KOHLER CO. WORK. ALL RIGHTS OF            DESIGN OR INVENTION ARE RESERVED.         </td> </tr> <tr> <td colspan="2"> <b>DWG. ASSY BATTERY CHARGER</b> </td> </tr> <tr> <td>SCALE 1:00</td> <td>CAD NO.</td> </tr> <tr> <td>DWG NO. <b>GM96391</b></td> <td>SHEET 1 of 1</td> </tr> </table>	<b>KOHLER CO. METRIC PRO-E</b> POWER SYSTEMS, KOHLER, WI 53044 U.S.A. THIS DRAWING IN DESIGN AND DETAIL IS KOHLER CO. PROPERTY AND MUST NOT BE USED EXCEPT IN CONNECTION WITH KOHLER CO. WORK. ALL RIGHTS OF DESIGN OR INVENTION ARE RESERVED.		<b>DWG. ASSY BATTERY CHARGER</b>		SCALE 1:00	CAD NO.	DWG NO. <b>GM96391</b>	SHEET 1 of 1
APPROVALS	DATE																			
DRWN SAK	3-4-15																			
CHECKED A.J.T	3-4-15																			
APPROVED JMS	3-4-15																			
<b>KOHLER CO. METRIC PRO-E</b> POWER SYSTEMS, KOHLER, WI 53044 U.S.A. THIS DRAWING IN DESIGN AND DETAIL IS KOHLER CO. PROPERTY AND MUST NOT BE USED EXCEPT IN CONNECTION WITH KOHLER CO. WORK. ALL RIGHTS OF DESIGN OR INVENTION ARE RESERVED.																				
<b>DWG. ASSY BATTERY CHARGER</b>																				
SCALE 1:00	CAD NO.																			
DWG NO. <b>GM96391</b>	SHEET 1 of 1																			

PART NO.	REV	VOLTS	WATTS	AMPS	THERMOSTAT TYPE/STYLE	REMOTE SENSOR TEMP. RANGE	TANK SENSOR TEMP RANGE	THREAD SIZE "A"	PLUG CONFIG.	LENGTH "B"	CORD TYPE	REMARKS
324930	W	120	1800	15.0	IN BLOCK/B	38*/49*C[100*/120*F]	49*/60*C[120*/140*F]	1/2 NPT	FIG-2	1575 [62.0]	1	-
324931	W	240	2000	8.3	IN BLOCK/B	38*/49*C[100*/120*F]	49*/60*C[120*/140*F]	1/2 NPT	FIG-3	1575 [62.0]	1	-
326220	W	120	1000	8.3	IN BLOCK/A	38*/49*C[100*/120*F]	49*/60*C[120*/140*F]	5/8-18 UNF 2A	FIG-1	1372 [54.0]	1	-
326221	W	240	1000	4.2	IN BLOCK/A	38*/49*C[100*/120*F]	49*/60*C[120*/140*F]	5/8-18 UNF 2A	FIG-3	1372 [54.0]	1	-
326222	W	120	1000	8.3	IN HOSE/C	27*/38*C[80*/100*F]	38*/49*C[100*/120*F]	-	FIG-1	1372 [54.0]	1	-
326224	Z	240	1000	4.2	IN HOSE/C	27*/38*C[80*/100*F]	38*/49*C[100*/120*F]	-	FIG-3	1372 [54.0]	1	-
326228	W	120	1500	12.5	IN BLOCK/A	38*/49*C[100*/120*F]	49*/60*C[120*/140*F]	1/2 NPT	FIG-1	1372 [54.0]	1	-
326229	W	240	1500	6.3	IN BLOCK/A	38*/49*C[100*/120*F]	49*/60*C[120*/140*F]	1/2 NPT	FIG-3	1372 [54.0]	1	-
326234	W	120	1800	15.0	IN BLOCK/A	38*/49*C[100*/120*F]	49*/60*C[120*/140*F]	1/2 NPT	FIG-2	1575 [62.0]	1	-
326235	W	240	2000	8.3	IN BLOCK/A	38*/49*C[100*/120*F]	49*/60*C[120*/140*F]	1/2 NPT	FIG-3	1575 [62.0]	1	-
326247	W	120	1500	12.5	IN BLOCK/A	38*/49*C[100*/120*F]	49*/60*C[120*/140*F]	5/8-18 UNF 2A	FIG-1	1372 [54.0]	1	-
326248	W	240	1500	6.3	IN BLOCK/A	38*/49*C[100*/120*F]	49*/60*C[120*/140*F]	5/8-18 UNF 2A	FIG-3	1372 [54.0]	1	-
336703	W	120	1500	12.5	IN HOSE/C	16*/27*C[60*/80*F]	38*/49*C[100*/120*F]	-	FIG-1	1372 [54.0]	1	-
352945	Y	120	1500	12.5	-	-	27*/38*C[80*/100*F]	-	FIG-1	1524 [60.0]	2	IN-BASE SENSING UNIT ONLY
352946	W	240	1500	6.3	-	-	27*/38*C[80*/100*F]	-	FIG-3	1219 [48.0]	2	IN-BASE SENSING UNIT ONLY
358311	Y	120	1000	8.3	-	-	27*/38*C[80*/100*F]	-	FIG-1	-	2	IN-BASE SENSING UNIT ONLY
358327	W	240	1000	4.2	-	-	27*/38*C[80*/100*F]	-	FIG-3	-	2	IN-BASE SENSING UNIT ONLY
GM23005	W	120	1800	15.0	IN BLOCK/D	27*/38*C[80*/100*F]	49*/60*C[120*/140*F]	28-1.25 6g METRIC	FIG-2	762 [30.0]	1	-
GM23006	W	240	2000	8.3	IN BLOCK/D	27*/38*C[80*/100*F]	49*/60*C[120*/140*F]	28-1.25 6g METRIC	FIG-3	762 [30.0]	1	-
GM24947	W	240	2000	8.3	IN BLOCK/A	38*/49*C[100*/120*F]	49*/60*C[120*/140*F]	M14-1.5 METRIC	FIG-3	1575 [62.0]	1	-
GM24948	W	120	1800	15.0	IN BLOCK/A	38*/49*C[100*/120*F]	49*/60*C[120*/140*F]	M14-1.5 METRIC	FIG-2	1575 [62.0]	1	-
GM28585	W	120	1000	8.3	-	-	27*/38*C[80*/100*F]	-	FIG-1	-	2	CORD THERMOSTAT [40*/60*F]
GM31942	Y	120	1000	8.3	IN BLOCK/A	27*/38*C[80*/100*F]	49*/60*C[120*/140*F]	1/2 NPT	FIG-1	1372 [54.0]	1	-
GM31943	Y	240	1000	4.2	IN BLOCK/A	27*/38*C[80*/100*F]	49*/60*C[120*/140*F]	1/2 NPT	FIG-3	1372 [54.0]	1	-
GM62682	Y	120	1000	8.3	-	-	27*/38*C[80*/100*F]	-	FIG-4	-	3	-
GM75552	AA	120	1800	15.0	-	-	27*/38*C[80*/100*F]	-	FIG-2	-	2	IN-BASE SENSING UNIT ONLY
GM75553	AA	240	2000	8.3	-	-	27*/38*C[80*/100*F]	-	FIG-3	-	2	IN-BASE SENSING UNIT ONLY
GM83980	AD	120	1000	8.3	-	-	16*/27*C[60*/80*F]	-	FIG-1	1524 [60.0]	2	IN-BASE SENSING UNIT ONLY INCLUDES THERMOSTAT TEMPERATURE DECAL
GM83981	AB	120	1500	12.5	-	-	16*/27*C[60*/80*F]	-	FIG-1	1219 [48.0]	2	IN-BASE SENSING UNIT ONLY INCLUDES THERMOSTAT TEMPERATURE DECAL
GM95436	-	120	500	4.2	-	-	27*/38*C[80*/100*F]	-	FIG-1	-	2	IN-BASE SENSING UNIT ONLY
GM95437	-	240	500	2.1	-	-	27*/38*C[80*/100*F]	-	FIG-3	-	2	IN-BASE SENSING UNIT ONLY
GM103846	-	120	1800	15.0	-	-	16*/27*C[60*/80*F]	-	FIG-2	-	2	IN-BASE SENSING UNIT ONLY

THIS IS AN MANUAL TABLE.

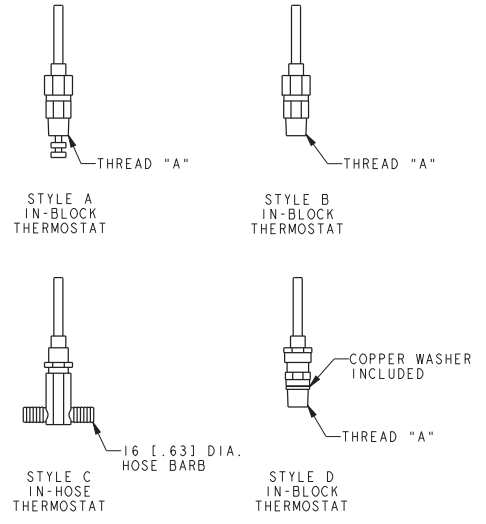

LEADS TO BE LABELED WITH WIRE MARKERS BY SUPPLIER, LABEL "N", "G", & "L1"

TERMINATE EACH LEAD WITH A 1/4 INCH INSULATED FEMALE PUSH-ON TERMINAL

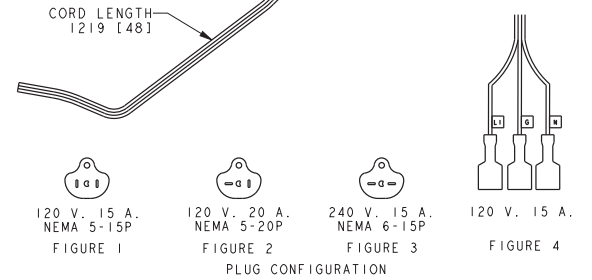
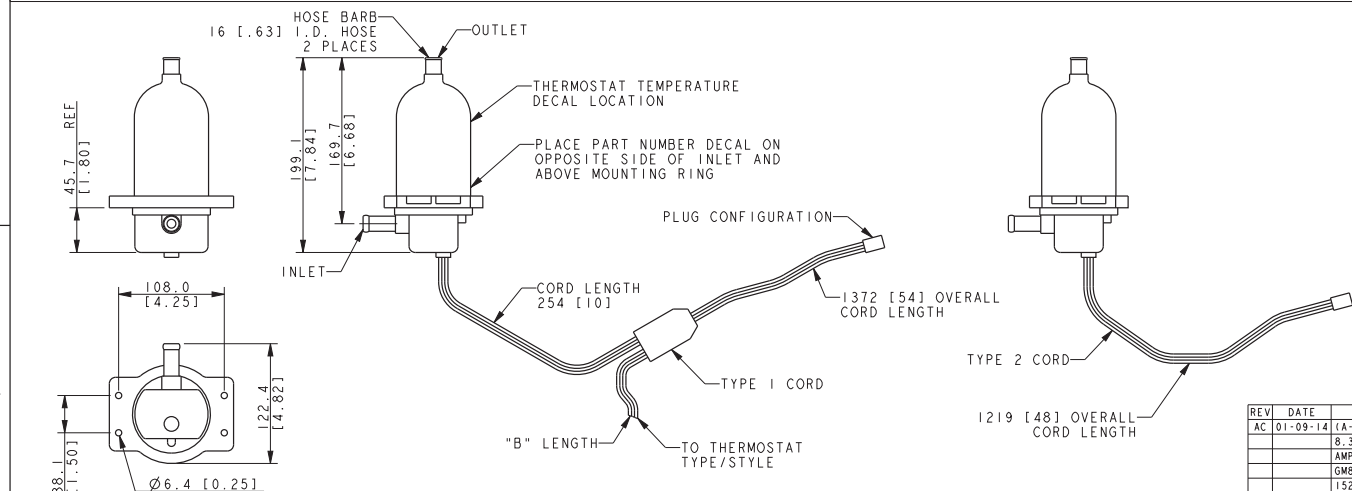

VALUES IN [ ] ARE ENGLISH EQUIVALENTS.

□ INDICATES PART NUMBERS AFFECTED BY LATEST REVISION

REV	DATE	ON COMPOSITE DWGS. SEE PART NO. FOR REVISION LEVEL	BY	UNLESS OTHERWISE SPECIFIED: 2) DIMENSIONS ARE IN MILLIMETERS 2) TOLERANCES ARE: X .XX ± 0.25 Z .P ± 1.5 SURFACE FINISH ANGLES ± 0° 30' / MAX.
AC	01-09-14	(A-1) 326220-CMP WAS 326220; (C-8) 358311 AMPS 8.3 WAS 4.2; GM31942 AMPS 8.3 WAS 12.5; GM31943 AMPS 4.2 WAS 6.3; GM62682 AMPS 8.3 WAS 4.2;		
		GM83980 AMPS 8.3 WAS 4.2; (D-4) 352945 "LENGTH 1524 WAS 1219" [CT68393]	PAS	
AD	3-11-14	(C-4) GM83980 "LENGTH" 1524 WAS 1219 [CT74793]	JMP	
AE	11-12-14	(B-8) GM95436 AND GM95437 ADDED [CT199196]	DRA	
AF	8-10-17	(B-8) GM103846 ADDED [CT177694]	SAM	
AG	4-10-19	(B-4) "CORD TYPE 2" ADDED FOR GM95436 & GM95437 [CT194828]	PAS	

REVISION BLOCK INDICATES REVISION LEVEL OF DRAWING NOT PART REVISION. SEE PART REVISION LEVEL BEHIND PART NUMBER FOR CURRENT PART REVISION LEVEL.

**KOHLER CO. METRIC PROE**

POWER SYSTEMS, KOHLER, WI 53044 U.S.A.  
THIS DRAWING IN DESIGN AND DETAIL IS KOHLER CO. PROPERTY AND MUST NOT BE USED EXCEPT IN CONNECTION WITH KOHLER CO. BATHS. ALL RIGHTS OF DESIGN OR INVENTION ARE RESERVED.

**DWG, HEATER, BLOCK**

SCALE 0.40 CAD NO. SHEET 1 of 1

**326220-CMP**

**KOHLER®**

# Warranty



# Stationary Standby and Prime Power Industrial Generator Set One-Year or Two Thousand (2000)-Hour Limited Warranty

Your Kohler product has been manufactured and inspected with care by experienced craftsmen. If you are the original end user, Kohler Co. warrants, for the period indicated below, each product to be free from defects in materials and workmanship. In the event of a defect in materials or workmanship, Kohler Co. will repair, replace, or make appropriate adjustment at Kohler Co.'s option if the product, upon Kohler Co.'s inspection, is found to be properly installed, maintained, and operated in accordance with Kohler Co.'s instruction manuals. A Kohler distributor, dealer, or authorized service representative must perform startup.

## Kohler Product

Stationary Standby Generator Set & Accessories

## Warranty Coverage

One (1) year from registered startup or two thousand (2000) hours (whichever occurs first). In any event, the warranty period will expire not later than thirty (30) months from the date of shipment from Kohler Co.'s factory.

Stationary Prime Power Generator Set & Accessories

One (1) year from registered startup or two thousand (2000) hours (whichever occurs first). In any event, the warranty period will expire not later than thirty (30) months from the date of shipment from Kohler Co.'s factory.

The following will **not** be covered by the warranty:

1. Normal wear, routine tuneups, tuneup parts, adjustments, and periodic service.
2. Damage, including but not limited to damage caused by accidents, improper installation or handling, faulty repairs not performed by an authorized Kohler service representative, improper storage, or acts of God.
3. Damage caused by operation at speeds, or with fuel, loads, conditions, modifications or installation contrary to published specifications.
4. Damage caused by negligent maintenance such as:
  - a. Failure to provide the specified type and sufficient quantity of lubricating oil.
  - b. Failure to keep the air intake and cooling fin areas clean.
  - c. Failure to service the air cleaner.
  - d. Failure to provide sufficient coolant and/or cooling air.
  - e. Failure to perform scheduled maintenance as prescribed in supplied manuals.
  - f. Failure to regularly exercise the generator set under load (stationary applications only).
5. Original installation charges and startup costs.
6. Starting batteries and the following related expenses:
  - a. Labor charges related to battery service.
  - b. Travel expenses related to battery service.
7. Additional expenses for repairs performed after normal business hours, i.e. overtime or holiday labor rates.
8. Rental of equipment during the performance of warranty repairs.
9. Removal and replacement of non-Kohler-supplied options and equipment.
10. Non-Kohler replacement parts. Replacement of a failed Kohler part with a non-Kohler part voids the warranty on that part.
11. Radiators replaced rather than repaired.
12. Fuel injection pumps not repaired by an authorized Kohler service representative.
13. Non-Kohler-authorized repair shop labor without prior approval from Kohler Co. Warranty Department.
14. Engine fluids such as fuel, oil, or coolant/antifreeze.
15. Shop supplies such as adhesives, cleaning solvents, and rags.
16. Expenses incurred investigating performance complaints unless the problem is caused by defective Kohler materials or workmanship.
17. Maintenance items such as fuses, lamps, filters, spark plugs, loose or leaking clamps, and adjustments.
18. Travel time and mileage exceeding 300 miles round trip.

To obtain warranty service, call 1-800-544-2444 for your nearest authorized Kohler service representative or write Kohler Co., Service Department, MS072, Kohler, WI 53044 USA.

**KOHLER CO. SHALL NOT BE LIABLE FOR SPECIAL, INCIDENTAL, AND/OR CONSEQUENTIAL DAMAGES OF ANY KIND including, but not limited to, incidental and/or consequential labor costs, installation charges, telephone charges, or transportation charges in connection with the replacement or repair of defective parts.**

This is our exclusive written warranty. We make no other express warranty nor is anyone authorized to make any on our behalf.

**ANY IMPLIED OR STATUTORY WARRANTY, INCLUDING ANY WARRANTY OF MERCHANTABILITY OR FITNESS FOR A PARTICULAR PURPOSE, IS EXPRESSLY LIMITED TO THE DURATION OF THIS WARRANTY. Some states do not allow limitations on how long an implied warranty lasts, or the exclusion or limitation of incidental and/or consequential damages, so the above limitation or exclusion may not apply to you.**

This warranty gives you specific legal rights, and you may also have other rights which vary from state to state.

# KOHLER®

KOHLER CO., Kohler, Wisconsin 53044  
Phone 920-457-4441, Fax 920-459-1646  
For the nearest sales/service outlet in the US and Canada, phone 1-800-544-2444  
KOHLERPower.com

TP-5374 12/15f

# Stationary Standby Industrial Generator Set Extended Five-Year or Three Thousand (3000)-Hour Comprehensive Limited Warranty

Your Kohler product has been manufactured and inspected with care by experienced craftsmen. If you are the original end user, Kohler Co. warrants, for the period indicated below, each product to be free from defects in materials and workmanship. In the event of a defect in materials or workmanship, Kohler Co. will repair, replace, or make appropriate adjustment at Kohler Co.'s option if the product, upon Kohler Co.'s inspection, is found to be properly installed, maintained, and operated in accordance with Kohler Co.'s instruction manuals. A Kohler distributor, dealer, or authorized service representative must perform startup.

## Kohler Product

Stationary Standby Generator Set & Accessories

## Warranty Coverage

Five (5) years from registered startup or three thousand (3000) hours (whichever occurs first).

**This warranty is effective only upon Kohler Co.'s receipt of an extended warranty registration form and warranty fee within one year of registered startup.** The comprehensive limited warranty start date is determined by the standard limited warranty requirements and runs concurrent with the standard limited warranty during the first year. To receive extended comprehensive limited warranty coverage, the provisions of the standard limited warranty registration must be met.

The following will **not** be covered by the warranty:

1. Normal wear, routine tuneups, tuneup parts, adjustments, and periodic service.
2. Damage, including but not limited to damage caused by accidents, improper installation or handling, faulty repairs not performed by an authorized Kohler service representative, improper storage, or acts of God.
3. Damage caused by operation at speeds, or with fuel, loads, conditions, modifications or installation contrary to published specifications.
4. Damage caused by negligent maintenance such as:
  - a. Failure to provide the specified type and sufficient quantity of lubricating oil.
  - b. Failure to keep the air intake and cooling fin areas clean.
  - c. Failure to service the air cleaner.
  - d. Failure to provide sufficient coolant and/or cooling air.
  - e. Failure to perform scheduled maintenance as prescribed in supplied manuals.
  - f. Failure to regularly exercise the generator set under load (stationary applications only).
5. Original installation charges and startup costs.
6. Starting batteries and the following related expenses:
  - a. Labor charges related to battery service.
  - b. Travel expenses related to battery service.
7. Engine coolant heaters, heater controls, and circulating pumps after the first year of the warranty period.
8. Additional expenses for repairs performed after normal business hours, i.e. overtime or holiday labor rates.
9. Rental of equipment during the performance of warranty repairs.
10. Removal and replacement of non-Kohler-supplied options and equipment.
11. Non-Kohler replacement parts. Replacement of a failed Kohler part with a non-Kohler part voids the warranty on that part.
12. Radiators replaced rather than repaired.
13. Fuel injection pumps not repaired by an authorized Kohler service representative.
14. Non-Kohler-authorized repair shop labor without prior approval from Kohler Co. Warranty Department.
15. Engine fluids such as fuel, oil, or coolant/antifreeze.
16. Shop supplies such as adhesives, cleaning solvents, and rags.
17. Expenses incurred investigating performance complaints unless the problem is caused by defective Kohler materials or workmanship.
18. Maintenance items such as fuses, lamps, filters, spark plugs, loose or leaking clamps, and adjustments.
19. Travel time and mileage exceeding 300 miles round trip.

To obtain warranty service, call 1-800-544-2444 for your nearest authorized Kohler service representative or write Kohler Co., Service Department, MS072, Kohler, WI 53044 USA.

**KOHLER CO. SHALL NOT BE LIABLE FOR SPECIAL, INCIDENTAL, AND/OR CONSEQUENTIAL DAMAGES OF ANY KIND including, but not limited to, incidental and/or consequential labor costs, installation charges, telephone charges, or transportation charges in connection with the replacement or repair of defective parts.**

This is our exclusive written warranty. We make no other express warranty nor is anyone authorized to make any on our behalf.

**ANY IMPLIED OR STATUTORY WARRANTY, INCLUDING ANY WARRANTY OF MERCHANTABILITY OR FITNESS FOR A PARTICULAR PURPOSE, IS EXPRESSLY LIMITED TO THE DURATION OF THIS WARRANTY. Some states do not allow limitations on how long an implied warranty lasts, or the exclusion or limitation of incidental and/or consequential damages, so the above limitation or exclusion may not apply to you.**

This warranty gives you specific legal rights, and you may also have other rights which vary from state to state.

# KOHLER®

KOHLER CO., Kohler, Wisconsin 53044  
Phone 920-457-4441, Fax 920-459-1646  
For the nearest sales/service outlet in the  
US and Canada, phone 1-800-544-2444  
KOHLERPower.com

TP-5561 8/16f

**KOHLER®**

# Certification

# Certificate of Registration

QUALITY MANAGEMENT SYSTEM - ISO 9001:2015

This is to certify that:

Kohler Power Systems  
N7650 Lakeshore Road  
Sheboygan  
Wisconsin  
53083  
USA

Holds Certificate No:

**FM 727336**

and operates a Quality Management System which complies with the requirements of ISO 9001:2015 for the following scope:

Design, manufacture, and distributor support for electrical generators, alternators, fuel tanks, automatic transfer switches and switchgear.

For and on behalf of BSI:

  
\_\_\_\_\_  
Carlos Pitanga, Chief Operating Officer Assurance – Americas

Original Registration Date: 1995-02-28

Latest Revision Date: 2021-10-29

Effective Date: 2021-11-07

Expiry Date: 2024-11-06

Page: 1 of 2



...making excellence a habit.™

Certificate No: **FM 727336**

Location	Registered Activities
Kohler Power Systems - GK 900 Highland Drive Bldg 604 Kohler Wisconsin 53004 USA	Manufacture of leads and harness, automatic transfer switches and switchgear. Distribution of generator sets.
Kohler Power Systems N7650 Lakeshore Road Sheboygan Wisconsin 53083 USA	Design, manufacture, and distributor support for electrical generators, automatic transfer switches and switchgear.
Kohler Power Systems 300 N Dekora Woods Blvd Saukville Wisconsin 53080 USA	Manufacture of fuel tanks, skids, fabricated components and generators.
Kohler Power Systems Muth Warehouse 2821 Muth Court Sheboygan Wisconsin 53083 USA	The distribution of generator sets.
Kohler Power Systems KWIP Warehouse 4327 County EE Sheboygan Wisconsin 53081 USA	Receiving, sequencing and warehousing of generator components.

Original Registration Date: 1995-02-28

Latest Revision Date: 2021-10-29

Effective Date: 2021-11-07

Expiry Date: 2024-11-06

Page: 2 of 2

This certificate remains the property of BSI and shall be returned immediately upon request.

An electronic certificate can be authenticated [online](http://www.bsigroup.com/ClientDirectory). Printed copies can be validated at [www.bsigroup.com/ClientDirectory](http://www.bsigroup.com/ClientDirectory)  
To be read in conjunction with the scope above or the attached appendix.

Information and Contact: BSI, Kitemark Court, Davy Avenue, Knowlhill, Milton Keynes MK5 8PR. Tel: + 44 345 080 9000  
BSI Assurance UK Limited, registered in England under number 7805321 at 389 Chiswick High Road, London W4 4AL, UK.  
A Member of the BSI Group of Companies.

G15-152 10/21

# PROTOTYPE TEST REPORT



Models Covered: **100REOZJF**  
Model Tested: **100REOZJE**  
Cooling System Tested: **50C**

Alternator Tested: **4S9**  
Engine Tested: **4045HF285L**  
Voltage Tested: **208V**

## GENSET

**Maximum power test** to assure that the prime mover and alternator have sufficient capacity to operate within specifications.

**Meets Rated Load**

**Steady-state load test** to ensure voltage stability meets or exceeds ISO8528-5 requirements and to verify compliance with steady state speed control specifications.

**± 0.25 %** Frequency Band

**± 0.50 %** Voltage Deviation

**Transient load tests** per NEMA MG1-32.18, and ISO 8528 to verify specifications of transient voltage regulation, voltage dip, voltage overshoot, recovery voltage, and recovery time. Values shown for model tested above. Please contact factory for additional details.

### Full Load Acceptance

**32.1 %** Voltage Dip

**3.90** Seconds of Recovery Time

**22.5 %** Frequency Dip

**3.70** Seconds of Recovery Time

### Full Load Rejection

**19.1 %** Voltage Overshoot

**1.50** Seconds of Recovery Time

**5.90 %** Frequency Overshoot

**0.40** Seconds of Recovery Time

**G3** ISO8528-5 Class (G1, G2, G3)

**NFPA 110 one step testing** to determine the amount of time required for the generator set to reach 90% voltage and frequency to allow the ATS to transfer.

**Complies with NFPA 110 Type 10**

**Vibrational analysis** to verify that generator vibrations are within acceptable limits per ISO 8528-9.

**Complies**

**Torsional analysis data** to verify torsional effects are not detrimental and that the generator set will provide dependable service as specified.

**Complies**

**Generator set cooling and air flow tests** to verify maximum operating ambient temperature. (Cooling system test results are available on TIB-118)

**Acoustical noise intensity and sound attenuation effects tests** (Acoustical noise results are available on TIB-114 & 115)

**Exhaust Back Pressure test** completed to demonstrate within engine limitation (Exhaust back pressure test results are available on TIB-119)

Models Covered: **100REOZJF**  
Model Tested: **100REOZJE**  
Cooling System Tested: **50C**

Alternator Tested: **4S9**  
Engine Tested: **4045HF285L**  
Voltage Tested: **208V**

## ALTERNATOR

**Alternator temperature rise test** per NEMA MG1-32.6. Standby and prime ratings of the alternator are established during this test.

**Alternator overload test** per NEMA MG1-32.8. Motor starting tests per NEMA MG1-32.18.5 to evaluate capabilities of generator, exciter, and regulator system.

**Three-phase symmetrical short-circuit test** per NEMA MG1-32.13 to demonstrate short circuit performance, mechanical integrity, ability to sustain short-circuit current.

**Harmonic analysis, voltage waveform deviation** per NEMA MG1-32.10 to confirm that the generator set is producing clean voltage within acceptable limits.

(Alternator detailed test results are available on TIB-102)

# Kohler Standby/Prime Generator Set Test Program

Testing is an integral part of quality assurance. In keeping with our uncompromising commitment to quality, safety, and reliability, every Kohler Standby/Prime power generator set undergoes an extensive series of prototype and production testing.

## Prototype Testing

Prototype testing includes the potentially destructive tests necessary to verify design, proper function of protective devices and safety features, and reliability expectations. Kohler's prototype testing includes the following:

- Alternator temperature rise test per NEMA MG1-32.6. Standby and prime ratings of the alternator are established during this test.
- Maximum power test to assure that the prime mover and alternator have sufficient capacity to operate within specifications.
- Alternator overload test per NEMA MG1-32.8.
- Steady-state load test to ensure voltage regulation meets or exceeds ANSI C84.1, NEMA MG1-32.17 requirements and to verify compliance with steady-state speed control specifications.
- Transient test to verify speed controls meets or exceeds specifications.
- Transient load tests per NEMA MG1-32.18, and ISO 8528 to verify specifications of transient voltage regulation, voltage dip, voltage overshoot, recovery voltage, and recovery time.
- Motor starting tests per NEMA MG1-32.18.5 to evaluate capabilities of generator, exciter, and regulator system.
- Three-phase symmetrical short-circuit test per NEMA MG1-32.13 to demonstrate short circuit performance, mechanical integrity, ability to sustain short-circuit current.
- Harmonic analysis, voltage waveform deviation per NEMA MG1-32.10 to confirm that the generator set is producing clean voltage within acceptable limits.

Torsional analysis data, to verify torsional effects are not detrimental and that the generator set will provide dependable service as specified, is available upon request.

Kohler offers other testing at the customer's request at an additional charge. These optional tests include power factor testing, customized load testing for specific application, witness testing, and a broad range of MIL-STD-705c testing. A certified test report is also available at an additional charge.

- Generator set cooling and air flow tests to verify maximum operating ambient temperature.
- Reliability tests to demonstrate product durability, followed by root cause analysis of discovered failures and defects. Corrective action is taken to improve the design, workmanship, or components.
- Acoustical noise intensity and sound attenuation effects tests.

## Production Testing

In production, Kohler Standby/Prime generator sets are built to the stringent standards established by the prototype program. Every Kohler generator set is fully tested prior to leaving the factory. Production testing includes the following:

- Stator and exciter winding high-potential test on all generators. Surge transient tests on stators for generators 180 kW or larger. Continuity and balance tests on all rotors.
- One-step, full-load pickup tests to verify that the performance of each generator set, regulator, and governor meets published specifications.
- Regulation and stability of voltage and frequency are tested and verified at no load, 1/4 load, 1/2 load, 3/4 load, and full-rated load.
- Voltage, amperage, frequency and power output ratings verified by full-load test.
- The proper operation of controller logic circuitry, prealarm warnings, and shutdown functions is tested and verified.
- Any defect or variation from specification discovered during testing is corrected and retested prior to approval for shipment to the customer.

**KOHLER**<sup>®</sup>

KOHLER CO. Kohler, Wisconsin 53044  
Phone 920-565-3381, Fax 920-459-1646  
For the nearest sales/service outlet in the  
US and Canada, phone 1-800-544-2444  
KohlerPowerSystems.com