

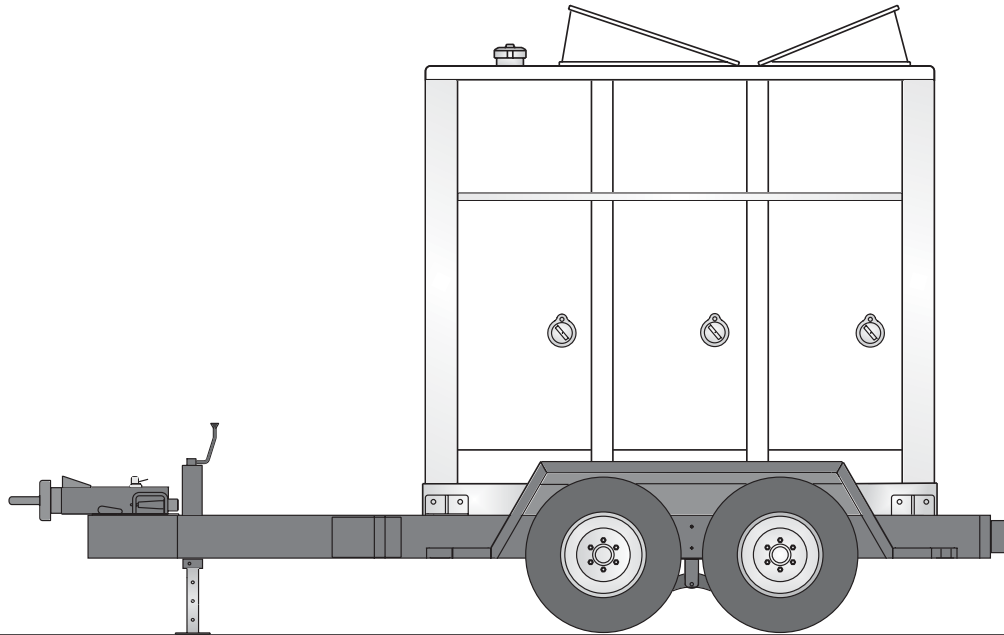

1800 Amp Diesel Studio Generator

Model	Emissions	Amperage 120/208 Line to Neutral x 3
EGS1800C3H	Tier 3 EPA Certified	1800 Amp
		60 Hertz



Standard Features:

- Cummins Water-Cooled Diesel Engine
- Marathon Alternator
- Sound Attenuated Aluminum Housing with Rounded Corners
- Custom Radiator with Multi-Wing Fan
- Dual Automatic Voltage Regulators with Changeover Switch
- Led Instrument Panel - Voltage, Amperage, Hertz
- Analog Engine Gauges - Coolant Temperature, Oil Pressure, Hourmeter, Battery Volts
- Outlet Panel
 - 4 sets - Camlock Receptacles
 - 2 - 100 Amp BATES Connectors
 - 2 - 15 Amp Edison Receptacles (Busbar Connectors available)
- Rotary Voltage Selector Switch - Two Position
- Variable Speed Hydraulic Fan Drive
- 120/240 Single Phase - 150 kW
- 120/208 Three Phase - 215 kW intermittent
- Main Line Circuit Breaker - 700 Amp
- Racor 900 Fuel/Water Filter
- Electric Priming Feature
- Crystal Sync Internal Electronic Engine Governor
- Internal DC Lighting with Timer
- Stainless Steel Water Lines, Exhaust Piping, Hinges and Outer Hardware
- Automatic Overhead Doors
- Inlet Rain Door with Automatic Intake Door Closure
- Critical Grade Exhaust Silencer with Rain Cap
- Murphy Engine Diagnostic Monitoring System
- B20 Bio-diesel Compliant Engine



1800 Amp Diesel Studio Generator

APPLICATION DATA

Alternator Specifications

Manufacturer/Model	Marathon Magnaplus / 431PSL6208
Type	4-Pole, Rotating field
Exciter Type	Brushless, voltage regulated
Number of Leads	12 Lead
Insulation	NEMA MG1-1.66
Material	Class H
Amortisseur Windings	Full
Generator RPM	1800
Power Factor	0.8
Coupling	Single bearing, flexible
Cooling Air Volume	1100 CFM
Voltage Regulation (no load to full load)	±1%
Single Step Load Acceptance per NFPA 110	100% of rating

- Compliant with NEMA MG1-22, BS5000, CSA-C22-2, IEC-34-1 standards for temperature rise.
- Sustained short-circuit current up to 300% of rated current for up to 10 seconds.
- Drip-proof, self-venting, amortisseur windings.
- Epoxy impregnated windings with tropical insulation for increased environmental protection and long life.
- Exceptional waveshape and voltage balance; 2/3 pitch winding to minimize harmonic distortion.
- Solid-state, volts-per-hertz voltage regulator with ±1% no-load to full-load voltage regulation.

Engine Specifications

Manufacturer/Model	Cummins / QSL9-G2
Type	4-cycle, charged air cooler, turbocharged
Cylinder Arrangement	6 In-Line
Displacement	8.8 L (543 in ³)
Bore	4.49 in. (114 mm)
Stroke	5.69 in. (145 mm)
Compression Ratio	16.8 : 1
Piston Speed	1707 ft/min (8.7 m/s)
Cylinder Block	Cast iron
Cylinder Head	Cast iron
Crankshaft	Nodular Iron
Brake Mean Effective Pressure (BMEP)	260 psi (1792 kPa)
Rated RPM	1800 RPM
Max. Power At Rated RPM (with fan)	320 hp (239 kWm)
Governor Type	Crystal Sync Electronic
Frequency Regulation: No load to full load	Isochronous under varying loads from no load to 100% rated load
Frequency Regulation: Steady State	±0.25% of mean value for constant loads from no load to full load
Air Cleaner Type	Replaceable, Paper insert

Amperage

Voltage	Phase	Amperage
120/240V	Single - zig zag	1200A total
120/208V	Three - 4 wire	1800A total

Fuel System

Fuel Injection Pump Make	Bosch HPCR
Recommended Fuel	ASTM-D975/No.2-D
Maximum Fuel Flow	43 gal/hr (165 L/hr)
Fuel Filters	Spin-on type
Trailer Fuel Tank Capacity	150 gal (567.7 L)
Fuel Consumption	
Diesel Fuel At % of Load	gal/hr (L/hr)
100%	16.8 (64)
75%	13.4 (51)
50%	9.3 (35)
25%	4.7 (18)

Exhaust System

Exhaust Flow at Rated kW	1095 cfm (31.0 m ³ /min)
Exhaust Temperature at Rated kW	1055°F (570°C)
Maximum Allowable Backpressure	41 in H ₂ O (10.1 kPa)
Heat Rejection To Exhaust	13350 Btu/min (235 kW)

Lubrication System

Type	Full pressure system
System Capacity-With Filter	7 gal (26.5 L)
Oil Filter	Full flow, spin-on
Oil Cooler	Full flow, integrated design
Oil Pressure At Rated Speed	40-60 psi (276-414 kPa)



1800 Amp Diesel Studio Generator

Cooling System

Exhaust Manifold	Dry type
Radiator Design	Horizontal Discharge
Ambient Temperature Rating	95°F (35°C)
Coolant Capacity (with radiator)	7.8 gal (29.5 L)
Coolant Flow	64 gal/min (242.2 L/min)
Radiator Cooling Air	9187 cfm (260 m ³ /min)
Heat Rejection to Charge Air Cooler	2770 Btu/min (50 kW)
Heat Rejection To Coolant	5603 Btu/min (98.5 kW)

Engine Electrical System

Battery Charging Alternator Make	Cummins
Ground Type	Negative
Volts (DC)	24V
Ampere Rating	65A
Starter Motor Make/Model	Cummins
Starter Motor Rated Voltage	24VDC
Starter Motor Battery Capacity	2 x 750 cca

GENERATOR CONTROLLER

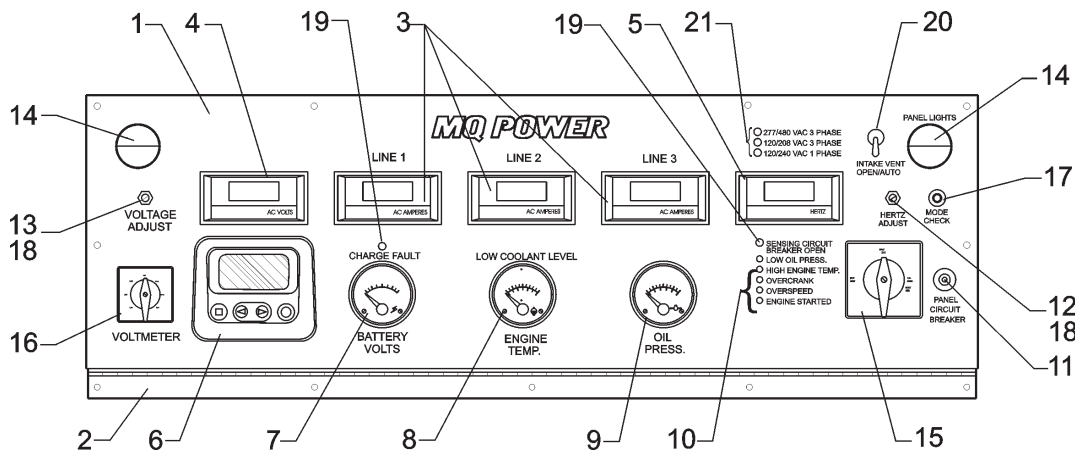

- | | | |
|-------------------------------------|----------------------------------|-----------------------------------|
| 1. AC Digital Panel | 8. Water Temp. Gauge | 15. Engine Control Switch |
| 2. Hinge Panel | 9. Oil Pressure Gauge | 16. Voltage Selector Switch |
| 3. LCD Ammeter 1000A | 10. Engine Control Unit | 17. Panel Light/Mode Check Switch |
| 4. LCD Voltage Meter | 11. Panel Circuit Breaker 10 Amp | 18. Locknut Pot Shift |
| 5. LCD Frequency Meter | 12. Speed Adjust Pot | 19. LED 24V DC Red |
| 6. Murphy Engine Diagnostic Display | 13. Voltage Adjust Pot | 20. Intake Vent Door Switch |
| 7. Voltmeter Gauge, 24 VDC | 14. Panel Lights | 21. Voltage Indicator LED |

CONTROLLER FEATURES

- EMI/RFI Noise Immunity and Surge Performance per IEEE C62.41
- Certified to UL508 and CSA 22.2 #14 Industrial Control Equipment Standards
- 12 or 24 Volt DC compatible
- Individual Ammeters - L1, L2, L3
- Volt Adjusting Rheostat
- Optional kW Meter available

■ ECU (Engine Control Unit)

- Solid State 5-Light Engine Monitor
Safety Shutdown and Fault Alarm for:
- Low Oil Pressure
 - High Coolant Temperature
 - Overspeed
 - Overcrank

Backfeed to a utility system can cause electrocution and/or property damage. Do not connect to any building's electrical system except through an approved device.

Specifications are subject to change without notice.



1800 Amp Diesel Studio Generator

Generator Set Optional Features:

- Block Heater
- Battery Charger
- 277/480 Volt Three Phase with Three Position Selector Switch
- 5 kVA Transformer (allows Edison receptacles to be "hot" in 480 Volt)
- Exterior Lighting Package
- Oil Level Sight Glass
- Outlet Panel Light
- Battery Disconnect Switch
- Stainless Steel Corners
- Forklift Pocket Skid Base
- Isolation Transformer
- B20 Bio-diesel Fuel Upgrade
- Dual Racor Filters
- Custom Paint Color
- Paralleling Gear (GAC)
- Oversized Alternator
- Generator Set Up with DC power
- Custom Outlet Panel
- Hubble Connectors (50 amp / 120/240V)
- Extra Bates Connectors (60 or 100 amp / 120V or 100 amp / 240V)
- Alternator with PMG and Digital Voltage Regulator
- Fire Extinguisher Box Flush Mounted in Housing
- 150 Gallon Sub-Base Fuel Tank (with forklift pockets)
- Distribution Boxes (Pin and Sleeve, Camlok Load Centers, Base Camp Packages etc.)
- Entertainment Cable

Trailer Standard Features:

- Tandem Axle Trailer with 150 Gallon Fuel Tank
- 8-Lug Chrome Wheels (5) with Chrome Center Caps and Lug Nuts
- Goodyear Wrangler Tires with Mounted Spare
- Tool Box
- Diamond Plate Decking
- Electric or Hydraulic Brakes

Trailer Option Features:

- Alcoa Aluminum Wheels (5)
- Electric Jack Stand
- Adjustable Style 10" Hitch
- Line-X Trailer Fenders and A-frame
- Ground Rod Holder
- Wheel Chalk Basket in A-frame
- LED Lighting
- Lockable Pintle Eye
- Rear Stabilizing Jacks

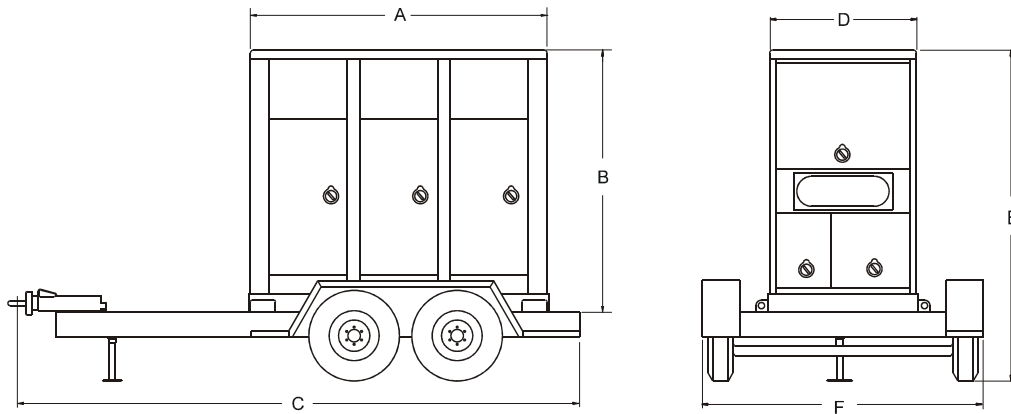

Weight and Dimensions						
Generator Set Dimensions with Trailer						
A	B	C		D	E	F
100 in.	87 in.	with Electric Brakes	with Hydraulic Brakes	48 in.	110.5 in.	72 in.
		173 in.	180 in.			
Appx. Net Weight - Generator				6600 lbs. (2994 kg)		
Appx. Net Weight - Trailer				2580 lbs (1170 kg)		
Trailer GVWR				12000 lbs (5443 kg)		

Your MQ Power dealer is:



MQ POWER
 POST OFFICE BOX 6254
 CARSON, CA 90749
 310-537-3700 • 800-421-1244
 FAX: 310-632-2656
 E-MAIL: mqpower@multiquip.com
 WEBSITE: www.mqpower.com