

Image shown may not reflect actual package.

CATERPILLAR® ENGINE SPECIFICATIONS

C18 In-Line 6, 4-Stroke-Cycle water-cooled diesel

Bore	145 mm (5.71 in.)
Stroke	183 mm (7.2 in.)
Displacement	18.13 L (1106.36 cu. in.)
Compression Ratio	14.5:1
Aspiration	Air-to-Air Aftercooled
Fuel System	MEUI
Governor Type	Caterpillar® ADEM™ A4 control system
Package Weight (estimated)	5032.61 kg (11,095 lb.)

Caterpillar is leading the power generation marketplace with Power Solutions engineered to deliver unmatched flexibility, expandability, reliability, and cost-effectiveness.

FEATURES

Ready to Run

- Shipped from the factory complete and ready to run

Fuel/Emissions Strategy

- Tier 2

Enclosures (design to order)

- Sound attenuated
- Weather protective

Single-Source Supplier

- Fully prototype-tested with certified torsional vibration analysis available
- Factory-designed systems built at Caterpillar ISO 9001:2000 certified facilities

Worldwide Product Support

- Caterpillar dealers provide extensive post-sale support including maintenance and repair agreements.
- Caterpillar dealers fill 99.7 percent of parts orders within 24 hours.
- Caterpillar dealers have over 2,100 dealer branch stores operating in 200 countries.
- The Cat® S•O•SSM program cost-effectively detects internal engine component condition, even the presence of unwanted fluids and combustion by-products.

Cat® C18 Tier 2 ATAAC Diesel Engine

- Utilizes ACERT™ Technology
- Reliable, rugged, durable design
- Field-proven in thousands of applications worldwide
- Four-stroke diesel engine combines consistent performance and excellent fuel economy with minimum weight
- Electronic engine control

Cat Generator

- Designed to match performance and output characteristics of Caterpillar diesel engines
- 2/3 pitch minimizes harmonic distortion and facilitates parallel operation
- UL 1446 Recognized Class H Insulation

Cat EMCP 3 Control Panels

- EMCP 3.1 offers basic engine/generator monitoring, metering, and protection.
- Segregated low voltage (AC/DC) accessory box provides single point access to accessory connections
- Panel lights

Web Site

For all your petroleum power requirements, visit www.cat-oilandgas.com.

STANDARD EQUIPMENT

Air Inlet System

- Dual element air cleaner
- Service indicator

Control Panels

- EMCP 3.1 (package mounted)

Controls

- Electronic governor

Cooling System

- Radiator with guard sized for 50° C
- Low coolant level sensor
- Coolant level sight gauge
- Coolant drain line with valve
- Fan and belt guards
- Caterpillar Extended Life Coolant

Exhaust System

- Turbo outlet elbow

Fuel System

- Primary fuel filter with integral water separator
- Secondary fuel filters
- Fuel priming pump
- Fuel pressure gauge
- Flexible fuel lines

Generator

- Self excited
- Class H insulation
- Class H temperature rise
- Random wound
- Voltage regulator
- Power terminal strip connections
- IP23 Protection
- CDVR 3-phase sensing
- Power center

Governor

- ADEM™ A4

Lube System

- Lubricating oil and filter
- Oil drain line with valves
- Fumes disposal
- Dipstick

Mounting System

- Oilfield skid base
- Hard mounted

Starting/Charging System

- 45-amp charging alternator
- 24-volt starting motor(s)
- Batteries with rack and cables
- Battery disconnect switch

General

- Paint — Caterpillar yellow except rails and radiators (gloss black)
- Flywheel and flywheel housing — SAE No. 1

OPTIONAL EQUIPMENT

Air Inlet System

- Heavy-duty air cleaner with precleaner

Control Panels

- EMCP 3.2 provides comprehensive monitoring, metering, and protection including: power metering, protective relaying and MODBUS communication.
- EMCP 3.3 provides all of the EMCP 3.2 features and adds the ability to expand the system for advanced engine and generator monitoring.
- Local alarm and remote annunciator modules
- Narrow base

OPTIONAL EQUIPMENT (continued)

Exhaust System

- Industrial, residential, and critical mufflers
- Stainless steel exhaust flex and ANSI weld flange

Generator

- Permanent magnet conversion for self-excited generators
- Oversize and premium generators
- Space heaters only available with permanent magnet excitation generators

Governor

- Load share module

Starting/Charging System

- Jacket water heater
- Block heater
- Oversize batteries

SPECIFICATIONS

Cat Generator

Voltage	480 V
Excitation	Self excited
Pitch	2/3
Number of poles	4
Number of leads	12
Insulation	UL 1446 Recognized Class H with tropicalization and antiabrasion (consult your Caterpillar dealer for available voltages)
IP Rating	Drip Proof IP22
Alignment	Pilot Shaft
Overspeed capability	125% of rated
Wave form deviation (line-to-line)	2%
Voltage regulation	Less than ± 1/2% (steady state) Less than ± 1/2% (with 3% speed change)
Harmonic Distortion	Less than 5%

Cat Control Panel

EMCP 3 Series Controls
24-Volt DC control
EMCP 3.1 (standard)
• CSA/CE
NEMA 1, IP22 enclosure
• Run/Auto/Stop control
• True RMS metering, 3-phase
• Speed adjust
Voltage adjust (optional)
• Digital indication for:
- rpm
- Operating hours
- Oil pressure
- Coolant temperature
- System DC volts
- L-L volts, L-N volts, phase amps, Hz
- ekW, kVA, kVAR, kW-hr, % kW, PF (*)
• Shutdowns
- Low oil pressure
- High coolant temperature
- Overspeed
- Emergency stop
- Failure to start (overcrank)
• Programmable protective relaying functions: (*)
- Under and over voltage
- Under and over frequency
- Reverse power
- Overcurrent
• MODUS isolated data link (RS-485 half-duplex) supports serial communication at data rate up to 115.2 kbaud (*)

(*) Available on EMCP 3.2 and EMCP 3.3
Single location customer connector point
Consult your Caterpillar dealer for available voltages

TECHNICAL DATA
Open Generator Set — 1800 rpm/60 Hz/480 Volts

EPA Certified Tier 2		DM8522
Generator Set Package Performance		
Genset Power Rating @ 0.8 pf	ekW	545
Genset Power Rating with fan	kVA	680
Coolant to Aftercooler		
Coolant to Aftercooler Temperature (maximum)	°C (F°)	49 (120)
Fuel Consumption		
100% Load with fan	L/hr (Gal/hr)	151.0 (39.9)
75% Load with fan	L/hr (Gal/hr)	123.4 (32.6)
50% Load with fan	L/hr (Gal/hr)	89.3 (23.6)
Cooling System¹		
Ambient Air Temperature	°C (F°)	52 (125.6)
Air Flow Restriction (system)	kPa (in. water)	.12 (.50)
Air Flow (max @ rated speed for radiator arrangement)	m ³ /min (cfm)	1866 (65,888)
Engine Coolant Capacity with Radiator/Expansion Tank	L (gal)	61 (16.1)
Engine Coolant Capacity	L (gal)	20.8 (5.5)
Radiator Coolant Capacity	L (gal)	40.2 (10.6)
Inlet Air		
Combustion Air Inlet Flow Rate	m ³ /min (cfm)	46.3 (1635.1)
Exhaust System		
Exhaust Stack Gas Temperature	°C (F°)	518.2 (964.8)
Exhaust Gas Flow Rate	m ³ /min (cfm)	129.6 (4576.8)
Exhaust System Backpressure (maximum allowable)	kPa (in. water)	10 (40.2)
Heat Rejection		
Heat Rejection to Coolant (total)	kW (Btu/min)	240 (13,660)
Heat Rejection to Exhaust (total)	kW (Btu/min)	573.0 (32,586)
Heat Rejection to Atmosphere from Engine	kW (Btu/min)	97 (5,539)
Heat Rejection to Atmosphere from Generator	kW (Btu/min)	21.9 (1245.4)
Alternator²		
Motor Starting Capability @ 30% Voltage Dip	skVA	
Frame		593
Temperature Rise	°C (F°)	105 (221)
Emissions (Nominal)³		
NOx	g/hr (lb/hr)	4,287 (9.45)
CO	g/hr (lb/hr)	340 (.75)
HC	g/hr (lb/hr)	10 (.02)
PM	g/hr (lb/hr)	27 (.06)

¹ Ambient capability at 300 m (984 ft) above sea level. For ambient capability at other altitudes, consult your Caterpillar dealer. Air flow restriction (system) is added to existing restriction from factory. Generator temperature rise is based on a 40° C (104° F) ambient per NEMA MG1-32.

² Generator temperature rise is based on a 40° C (104° F) ambient per NEMA MG1-32.

³ Emissions data measurement procedures are consistent with those described in EPA CFR 40 Part 89, Subpart D & E and ISO8178-1 for measuring HC, CO, PM, and NOx. Data shown is based on steady state operating conditions of 77°F, 28.42 in. HG and number 2 diesel fuel with 35° API and LHV of 18,390 btu/lb. The nominal emissions data shown is subject to instrumentation, measurement, facility, and engine-to-engine variations. Emissions data is based on 100% load and thus cannot be used to compare to EPA regulations which use values based on a weighted cycle.

C18 OIL FIELD GENERATOR SET PACKAGES

Engine Model	60 Hz — Standard		50 Hz — Standard
	C18	C18	C18
ekW Rating	500	545	440
kVA Rating	625	680	550
rpm	1800	1800	1500
Rated PF	0.8	0.8	0.8
Temperature Rise	105° C	105° C	105° C
Tilt Requirements	5° Static	5° Static	5° Static
Insulation Class	H	H	H
Overload	50%/2 min.	50%/2 min.	50%/2 min.
Excitation	SE	SE	SE
Voltage	480	480	400
Voltage Regulator	CDVD	CDVD	CDVD
Configuration	1-Brg	1-Brg	1-Brg
Coastal Protection	Yes	Yes	Yes
Space Heater	Opt.	Opt.	Opt.
Construction	RW	RW	RW
Short Circuit Current	300%/10 sec.	300%/10 sec.	300%/10 sec.
Frame Size	592	593	593

Generator Terminal Box

Terminal box shall be standard with terminals on the right side, top entry or rear depending on size. Normal cable entrance shall be from the top.

C18 OIL FIELD GENERATOR SET PACKAGES — OPTIONAL

Engine Model	60Hz						50Hz
	C18	C18	C18	C18	C18	C18	C18
ekW Rating	500	500	500	545	545	545	440
kVA Rating	625	625	625	680	680	680	550
rpm	1800	1800	1800	1800	1800	1800	1500
Rated PF	0.8	0.8	0.8	0.8	0.8	0.8	0.8
Temperature Rise	105° C	105° C	105° C	80° C	105° C	105° C	105° C
Tilt Requirements	5° Static	5° Static	5° Static	5° Static	5° Static	5° Static	5° Static
Insulation Class	H	H	H	H	H	H	H
Overload	50%/2 min.	50%/2 min.	50%/2 min.	50%/2 min.	50%/2 min.	50%/2 min.	50%/2 min.
Excitation	SE	PM	PM	SE	PM	PM	PM
Voltage	600	480	600	600	480	600	400
Construction	FW	RW	FW	FW	RW	FW	RW
Voltage Regulator	CDVR	CDVR	CDVR	CDVR	CDVR	CDVR	CDVR
Configuration	1-Brg	1-Brg	1-Brg	1-Brg	1-Brg	1-Brg	1-Brg
Coastal Protection	Yes	Yes	Yes	Yes	Yes	Yes	Yes
Space Heater	Yes	Yes	Yes	Yes	Yes	Yes	Yes
Short Circuit Current		300%/10 sec.	300%/10 sec.		300%/10 sec.	300%/10 sec.	—
Frame Size	592	592	592	597	593	593	593

C18 OIL FIELD GENERATOR SET PACKAGES — DESIGN TO ORDER (60 Hz)

Engine Model	C18	C18	C18	C18	C18	C18
ekW Rating	500	500	500	545	545	545
kVA Rating	715	715	625	780	780	680
rpm	1800	1800	1800	1800	1800	1800
Rated PF	0.7	0.7	0.8	0.7	0.7	0.8
Temperature Rise	80° C	90° C	90° C	80° C	90° C	90° C
Tilt Requirements	5° Static	5° Static	5° Static	5° Static	5° Static	5° Static
Insulation Class	H	H	H	H	H	H
Overload	50%/2 min.	50%/2 min.	50%/2 min.	50%/2 min.	50%/2 min.	50%/2 min.
Excitation	SE	PM	SE	SE	PMG	SE
Voltage	600	480	600	600	480	600
Voltage Regulator	CDVR	CDVR	CDVR	CDVR	CDVR	CDVR
Configuration	1-Brg	1-Brg	1-Brg	1-Brg	1-Brg	1-Brg
Coastal Protection	Yes	Yes	Yes	Yes	Yes	Yes
Construction	RW	FW	RW	RW	FW	RW
Short Circuit Current		300%/10 sec.			300%/10 sec.	

Optional Generator

For the 455, 500, and 545 ekW generator set a 600 volt generator shall be available as SE, without a voltage regulator. The 480 volt generator shall be PM for the same ratings. The SCR optional generator is for drill rig applications and the VFD optional generators are for variable frequency down-hole pump and single-unit drilling. The Multiple VFD generators should be developed if the generator costs do not exceed 5% compared to the single VFD generator development costs.

INSTALLATION DRAWINGS

Front View

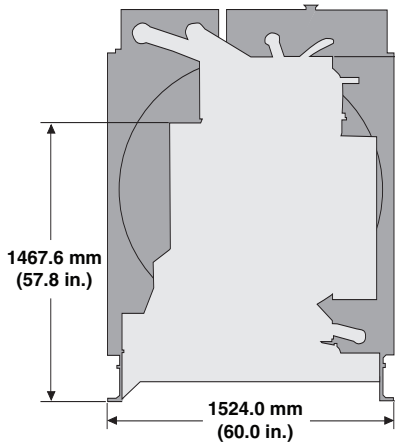

Right Side View

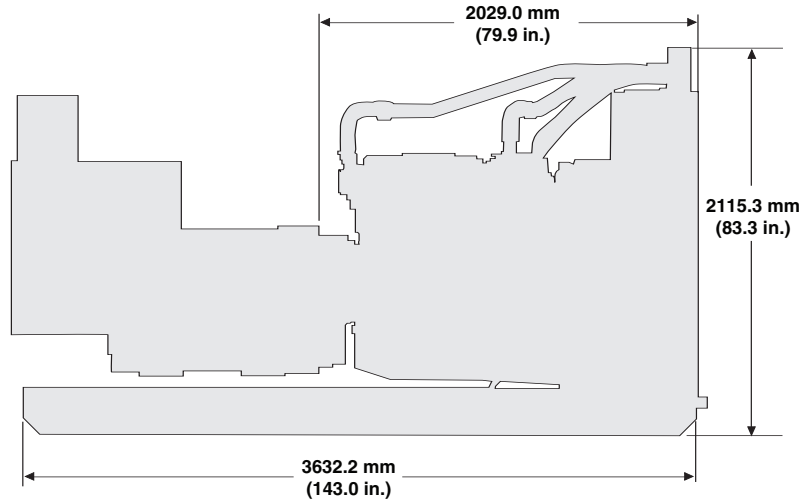

Note: Package dimensions may change depending on generator arrangement selection.

Package Dimensions		
Length	3632.2 mm	143.0 in.
Width	1524.0 mm	60.0 in.
Height	2115.8 mm	83.3 in.
Weight (estimated)	5032.61 kg	11,095 lb.

Note: Do not use for installation design. See general dimension drawings for detail.

RATING DEFINITIONS AND CONDITIONS

Meets or Exceeds International Specifications:

AS1359, AS2789, CSA, EGSA101P, IEC60034, ISO3046, ISO8528, NEMA MG 1-32, UL508, 72/23/EEC, 89/336/EEC, 98/37/EEC.

Prime output available with varying load for an unlimited time. Prime power in accordance with ISO8528. 10 percent overload power in accordance with ISO3046, AS2789, and BS5514 available on request. Prime power ambients shown indicate ambient at 100 percent load which results in a coolant top tank temperature just below the alarm temperature.

Ratings are based on SAE J1995 standard conditions.

These ratings also apply at ISO3046 standard conditions. Fuel rates are based on fuel oil of 35° API [16° C (60° F)] gravity having an LHV of 42 780 kJ/kg (18,390 Btu/lb) when used at 29° C (85° F) and weighing 838.9 g/liter (7.001 lbs/U.S. gal.). Additional ratings may be available for specific customer requirements. Consult your Caterpillar representative for details.

THIS PAGE
INTENTIONALLY
LEFT BLANK



Materials and specifications are subject to change without notice. The International System of Units (SI) is used in this publication. CAT, CATERPILLAR, their respective logos, S•O•S, ACERT, ADEM, "Caterpillar Yellow" and the POWER EDGE trade dress, as well as corporate and product identity used herein, are trademarks of Caterpillar and may not be used without permission.